





STEP 36

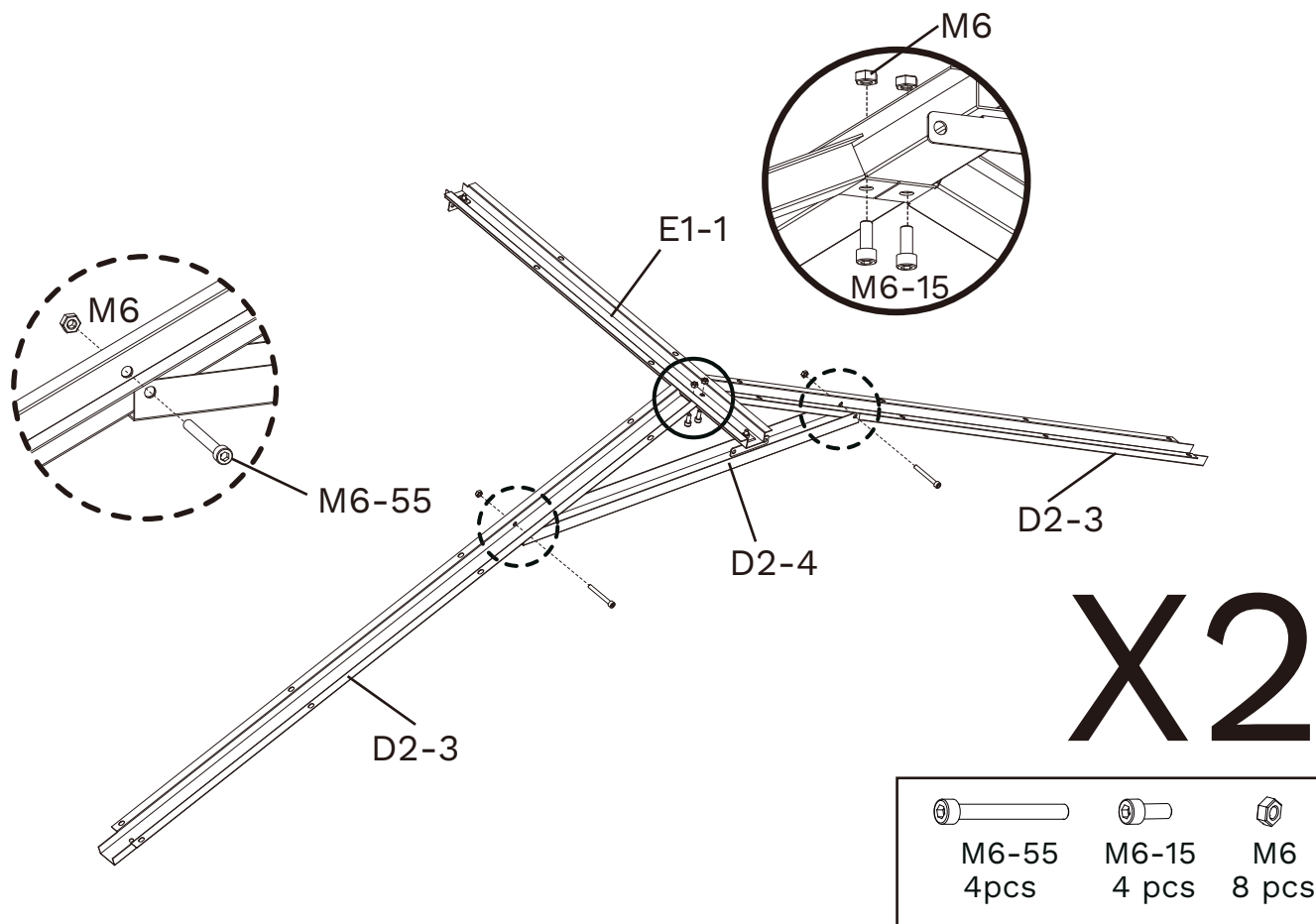

| | |
|---|---|
|  |  |
| M6-15 | M6 |
| 4 pcs | 4 pcs |

STEP 37

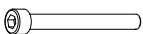

| | | |
|---|---|---|
|  |  |  |
| M6-55 | M6-15 | M6 |
| 4 pcs | 4 pcs | 8 pcs |

STEP 38

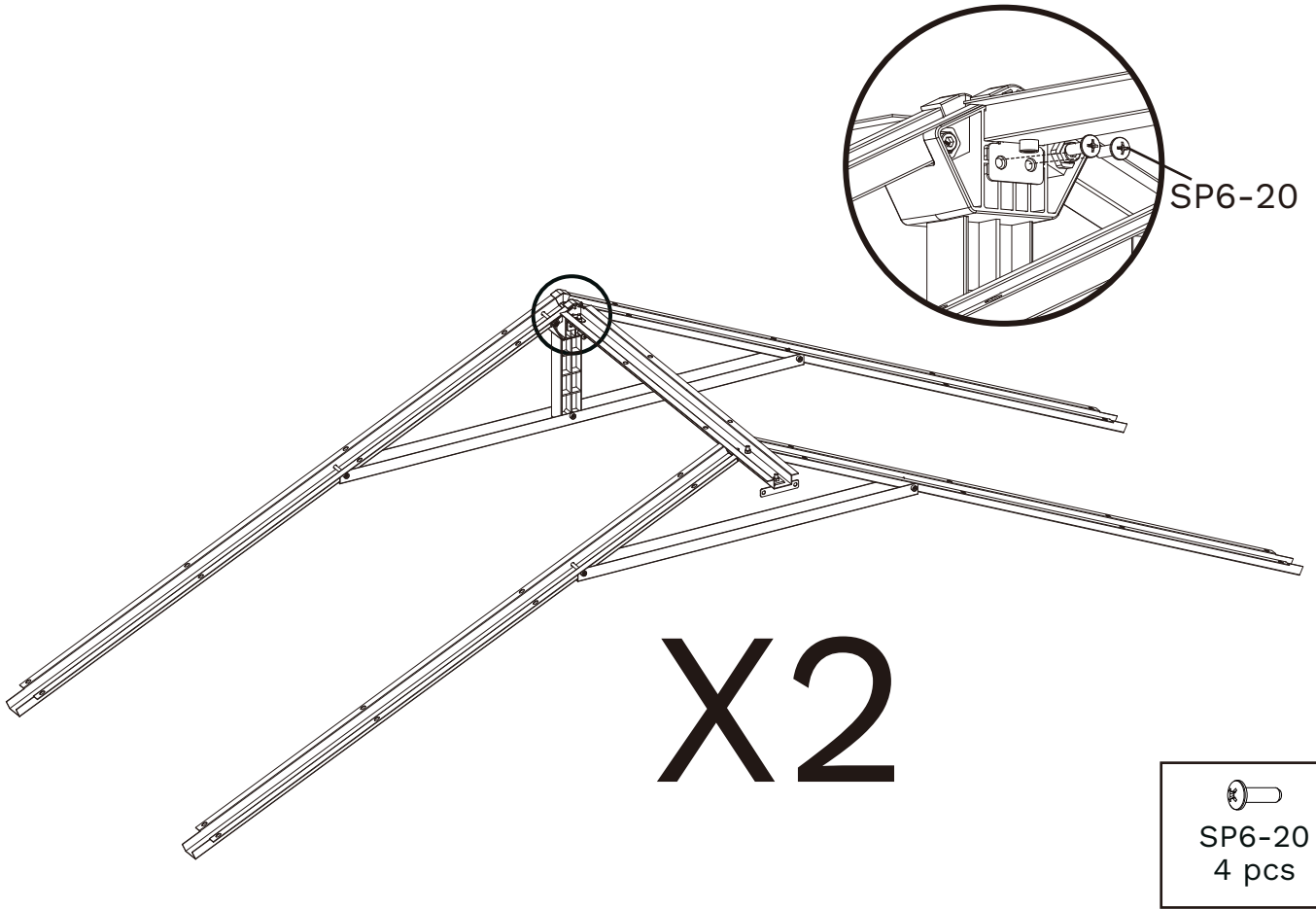

STEP 39

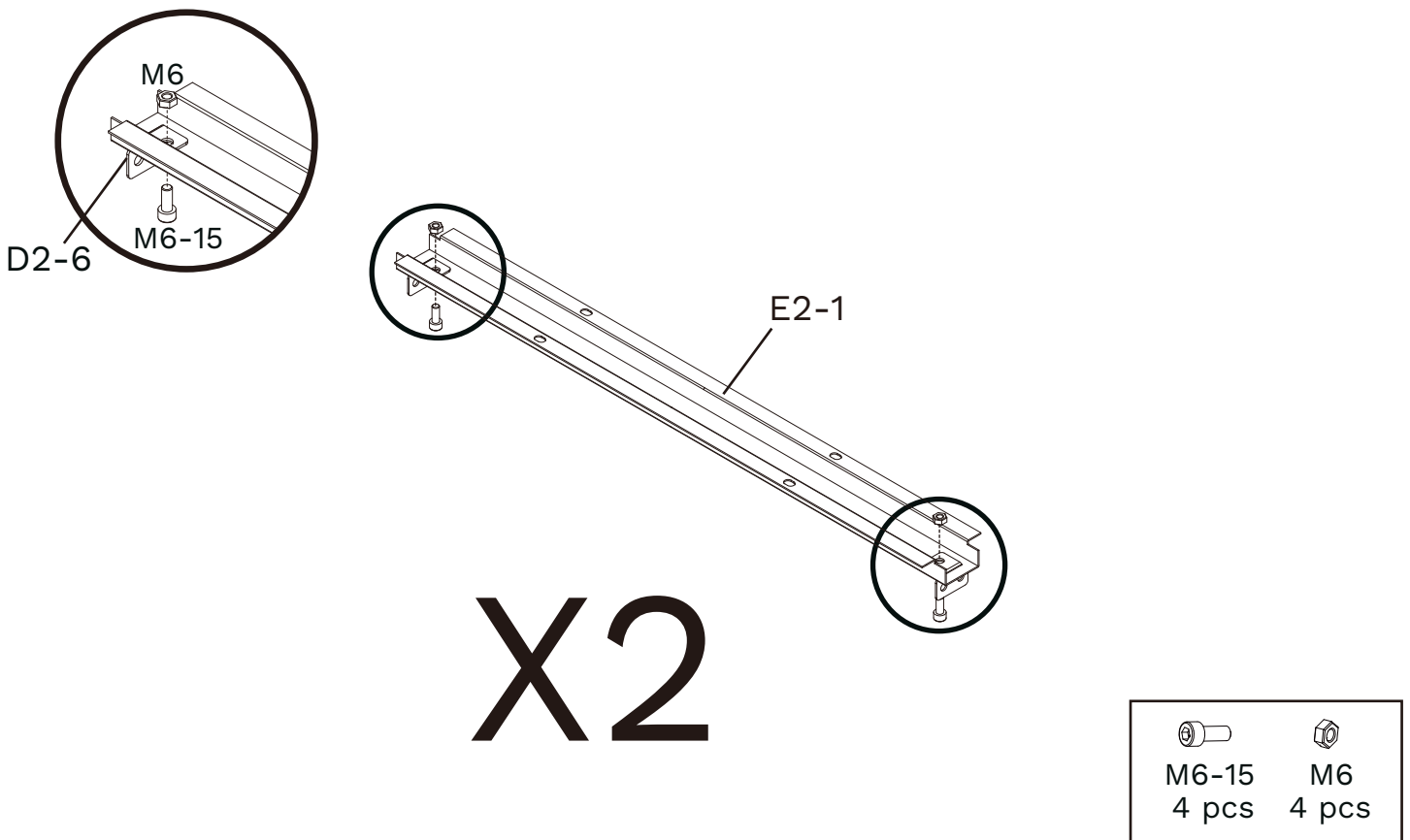

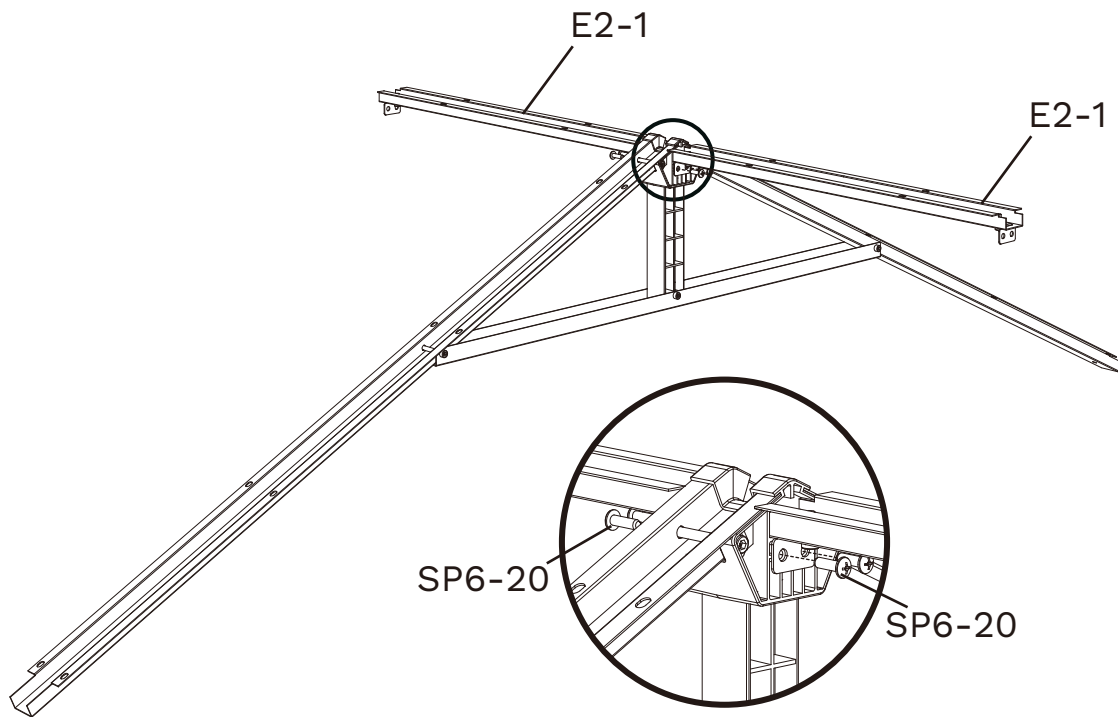

STEP 40



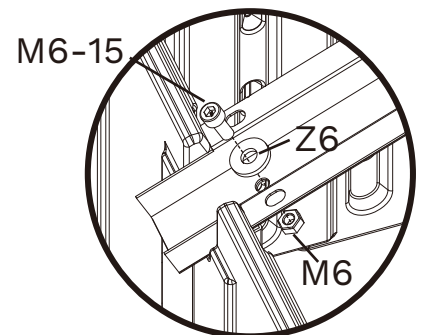
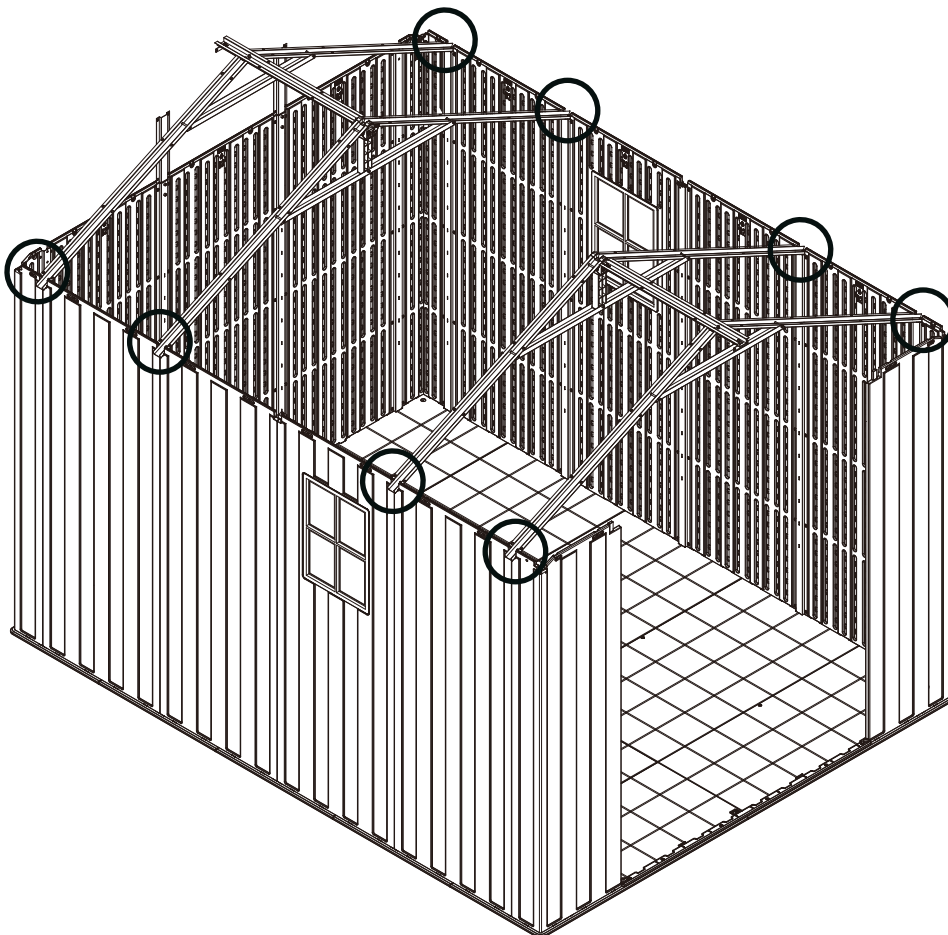

SP6-20
4 pcs

STEP 41







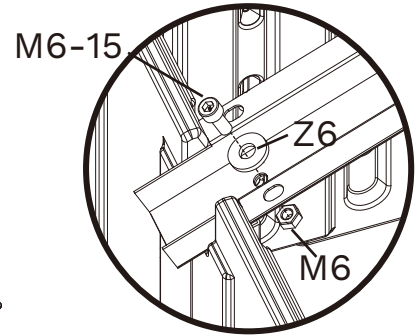
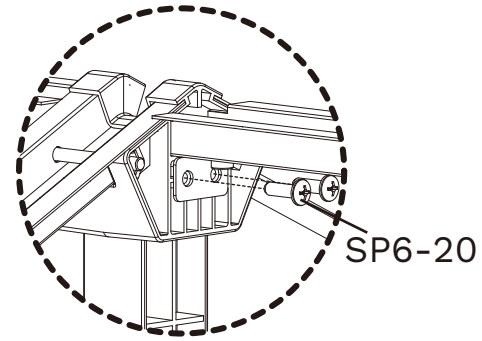
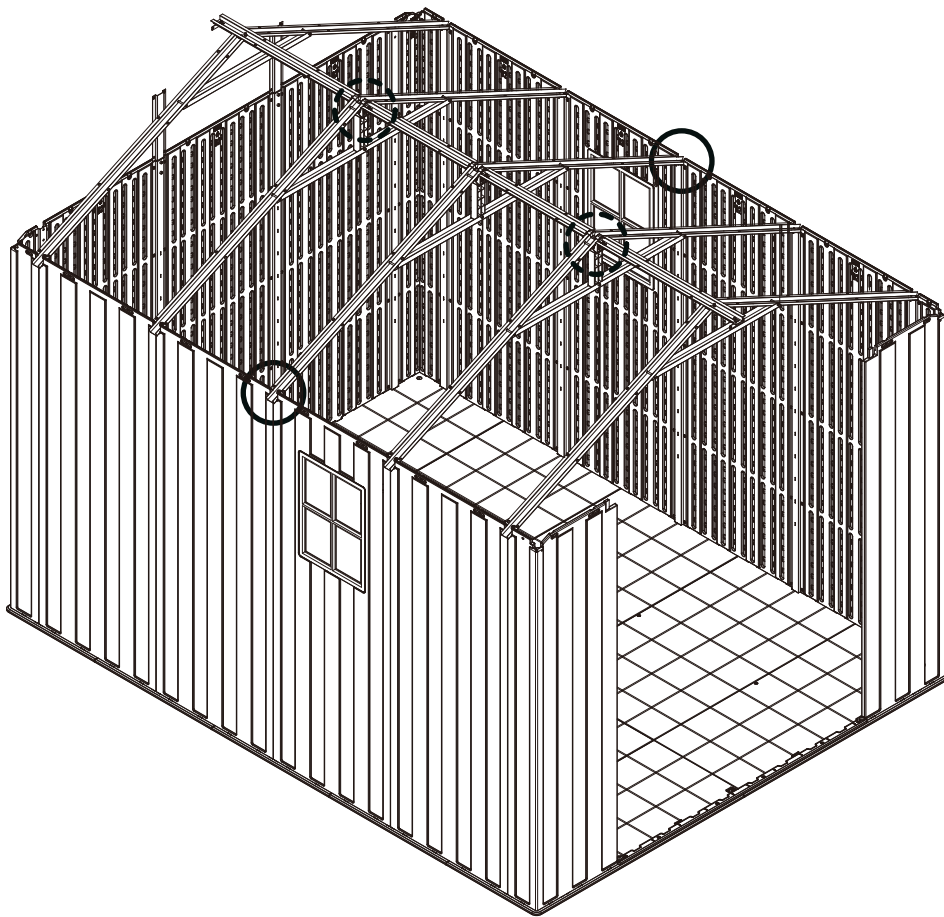

M6-15
8 pcs

M6
8 pcs



Z6
8 pcs

STEP 42

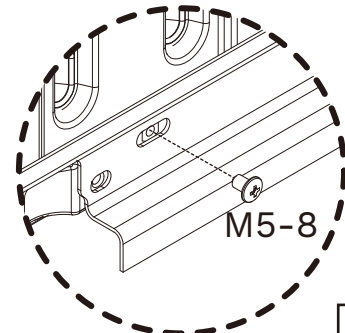
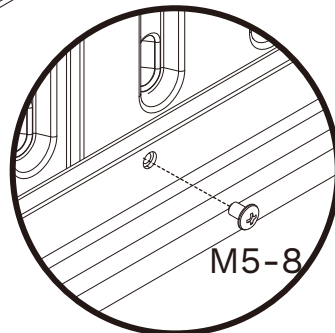
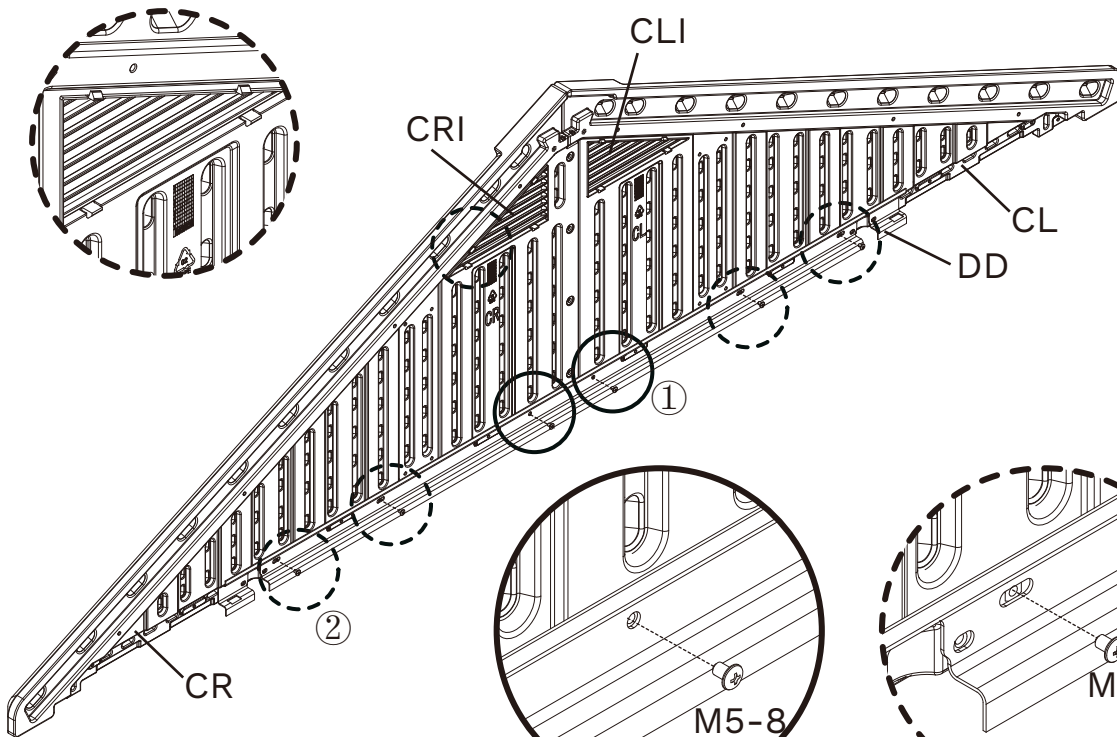

| | | | |
|---|---|---|---|
|  |  |  |  |
| M6-15 | M6 | Z6 | SP6-20 |
| 2 pcs | 2 pcs | 2 pcs | 4 pcs |

STEP 43



| |
|---|
|  |
| M5-8 |
| 6 pcs |

STEP 44

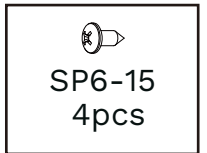
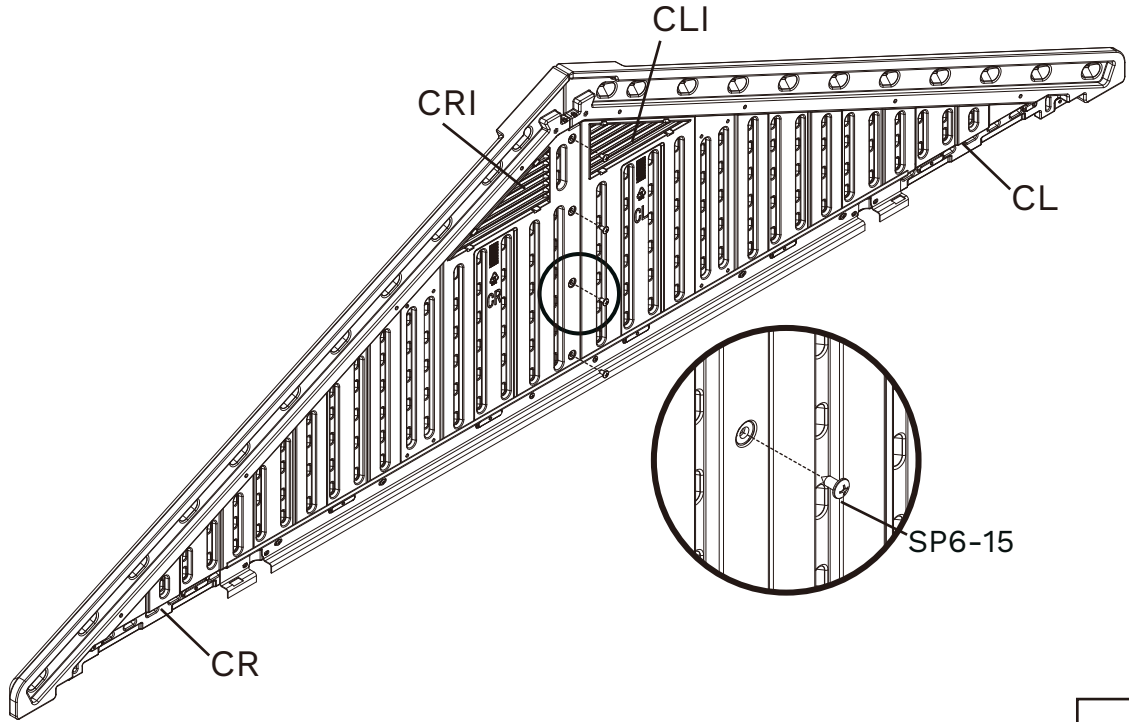

STEP 45

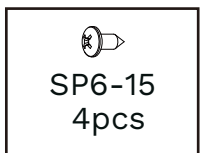
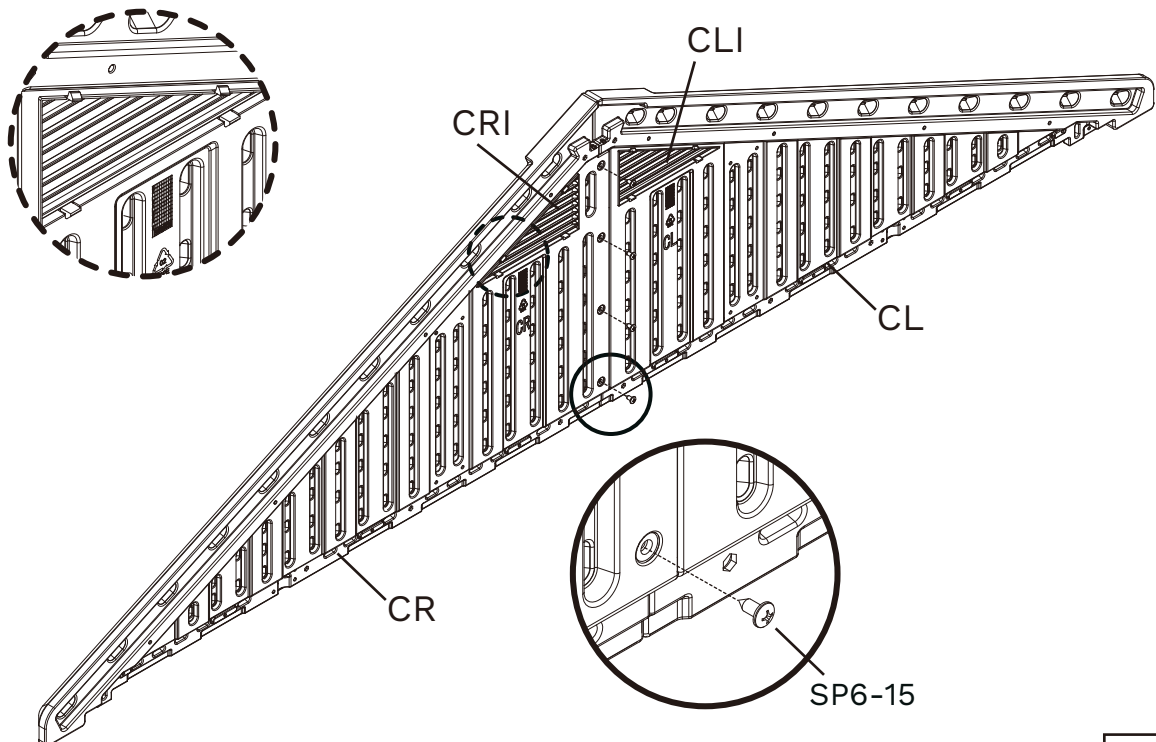

STEP 46

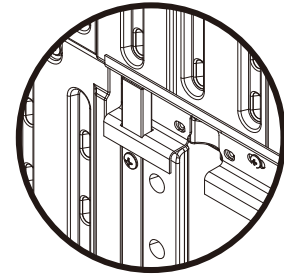
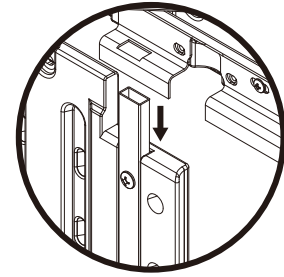
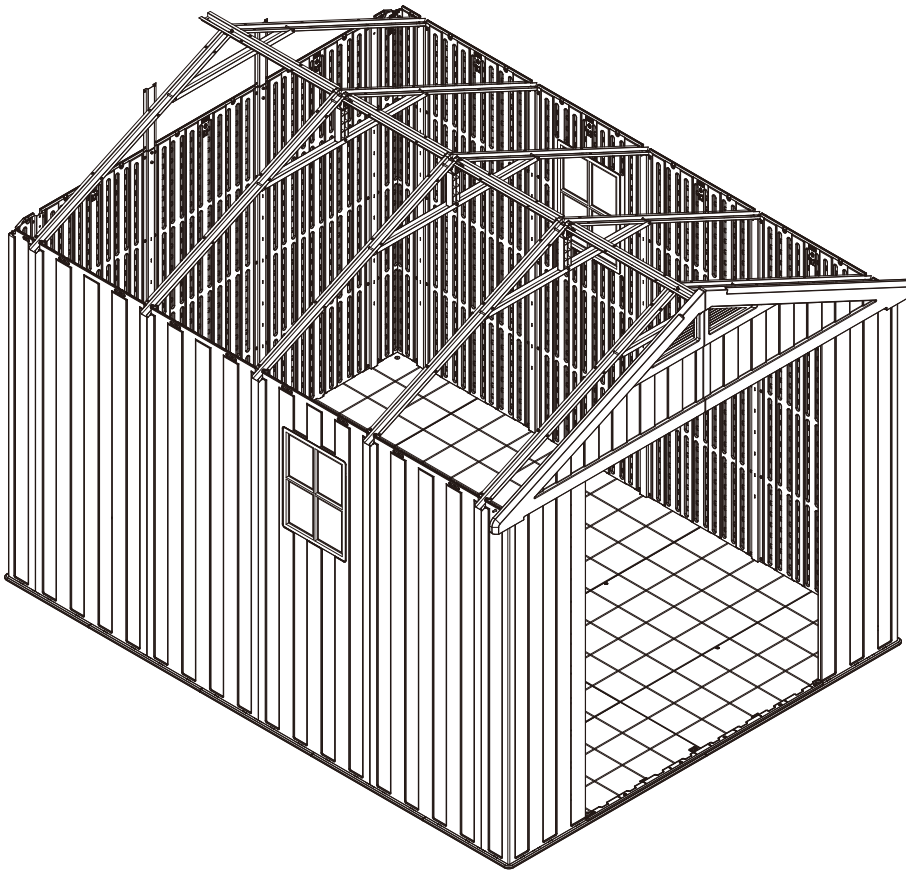

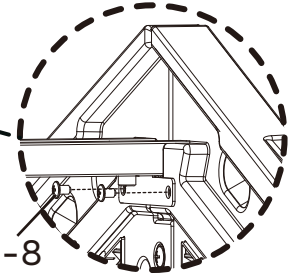
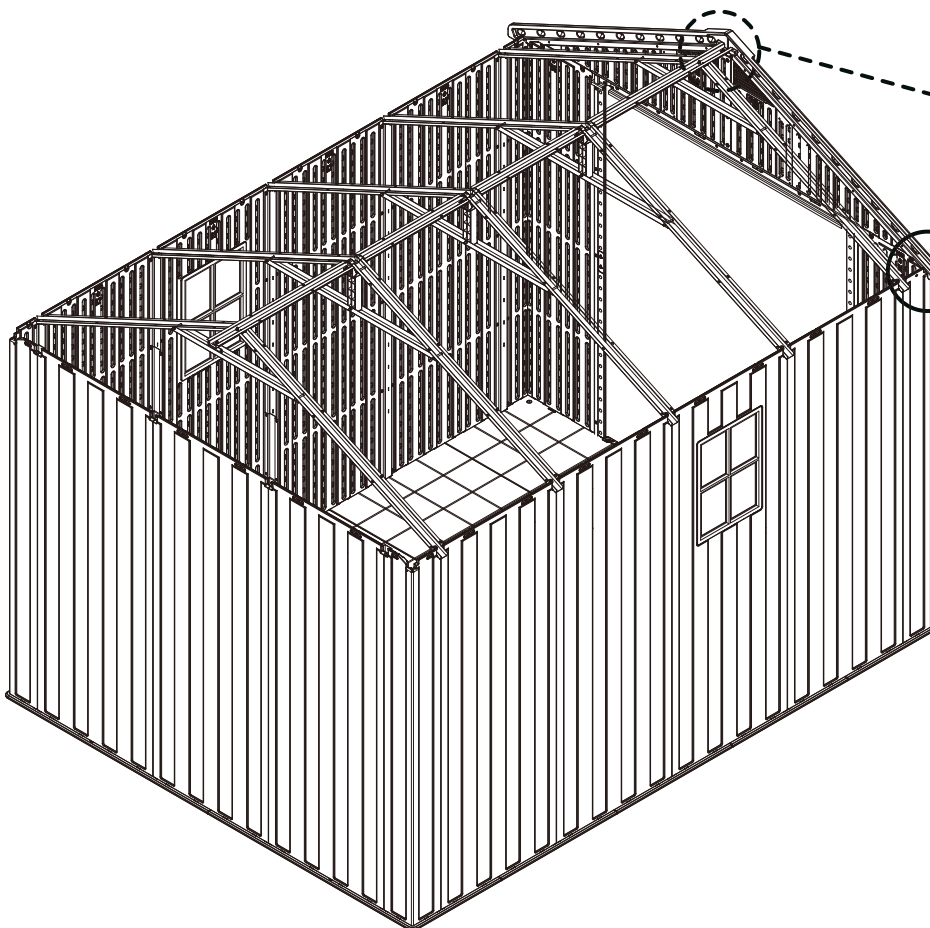

STEP 47

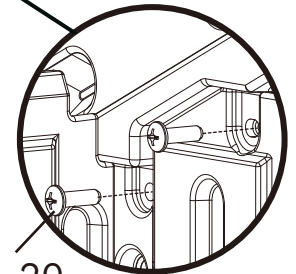

M5-8



SP6-20

| | |
|---|---|
|  |  |
| SP6-20 | M5-8 |
| 6 pcs | 2 pcs |

STEP 48

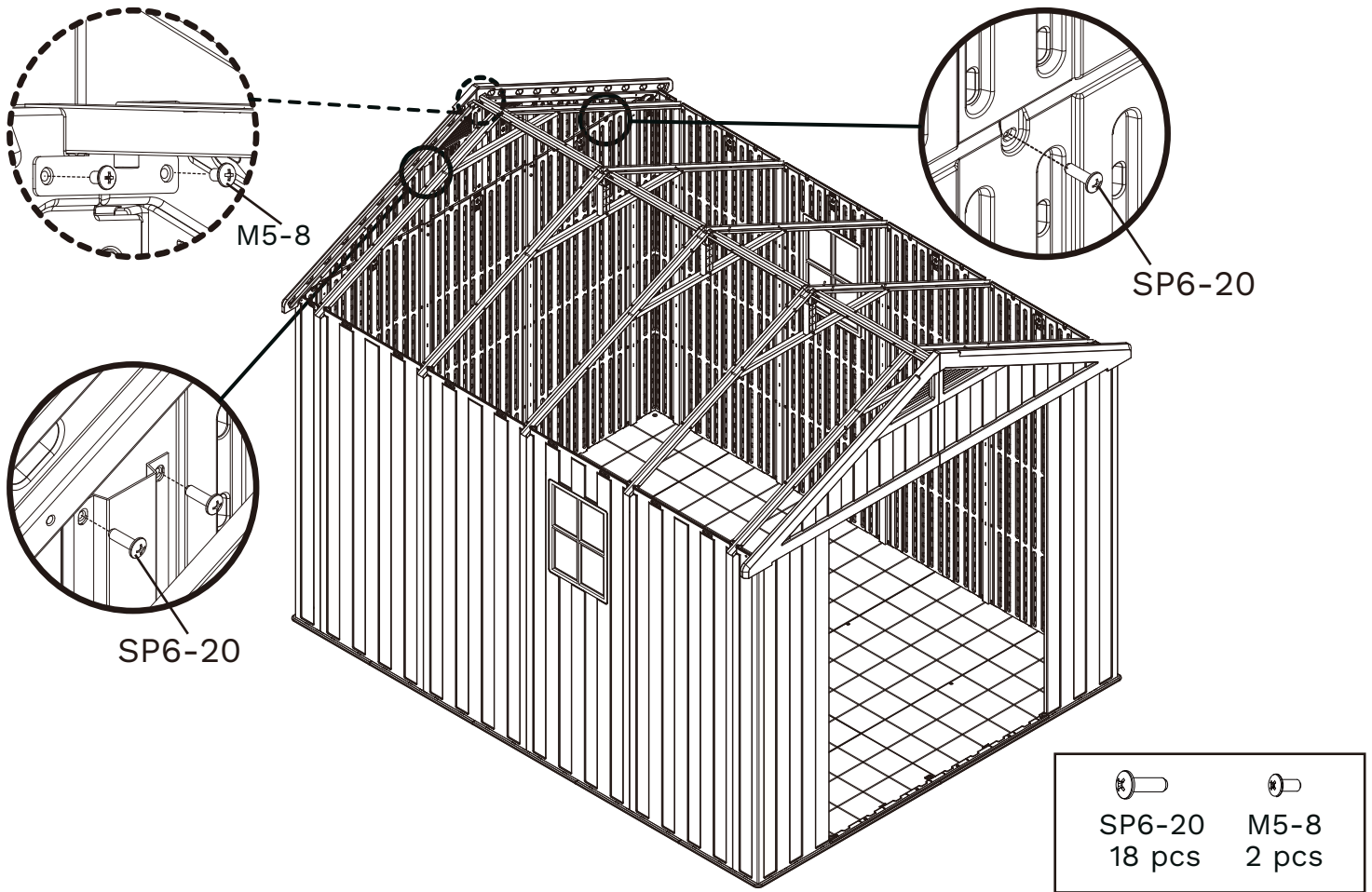

STEP 49

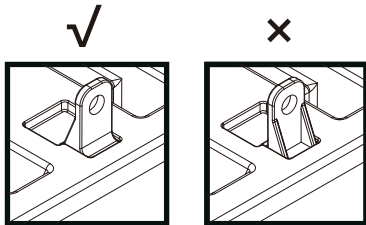

Note the mounting direction of D4.

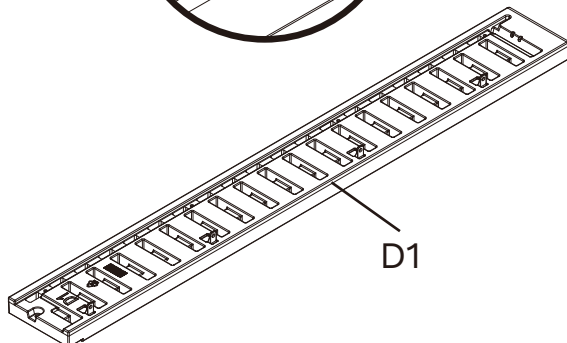
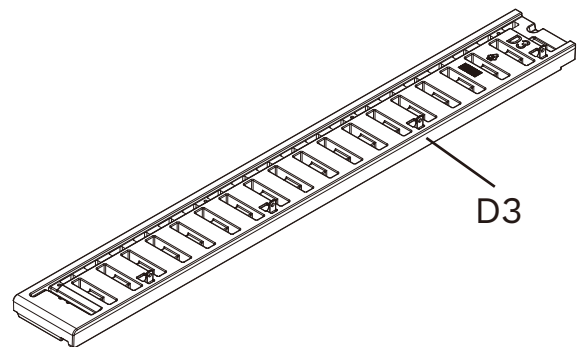
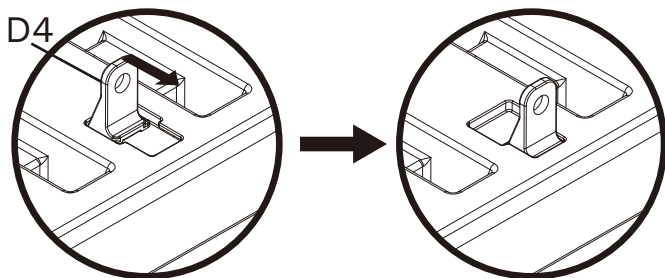

X2

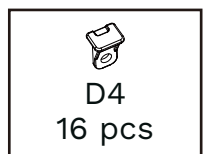

STEP 50

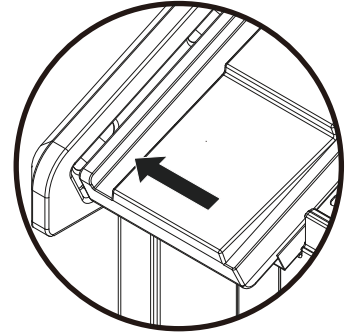
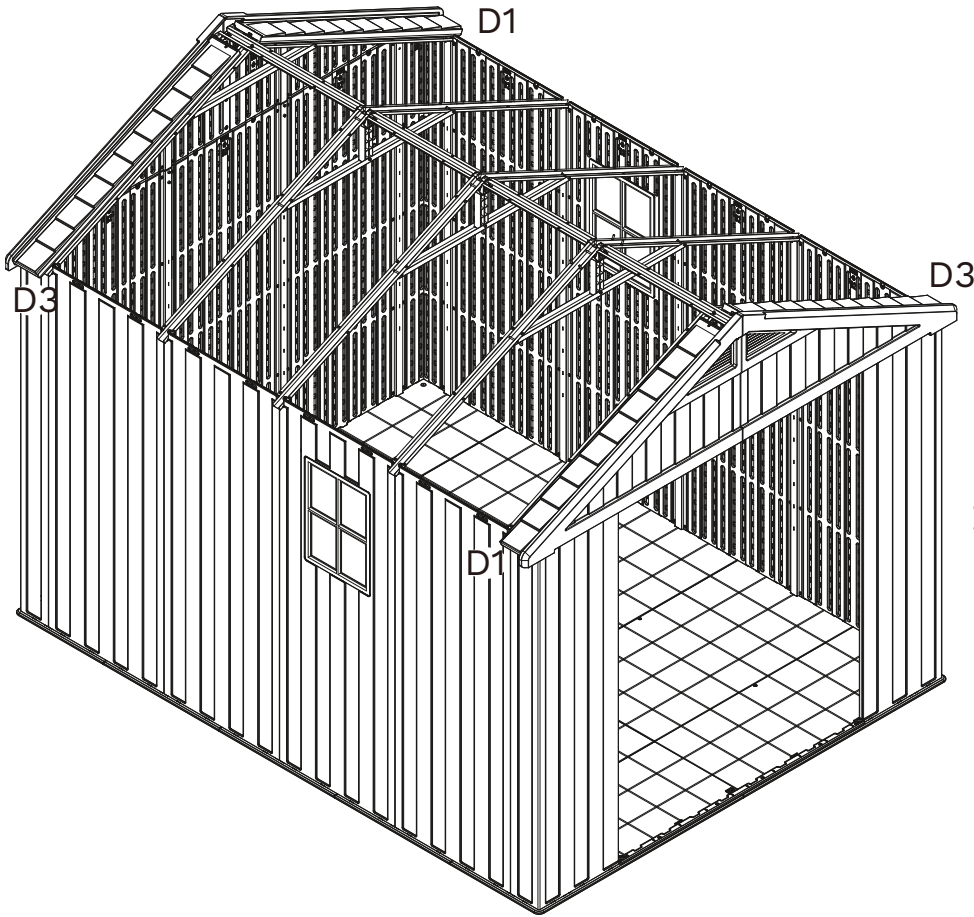

D1 and D3 are placed in the grooves of the iron frame, aligned with the grooves of the CL CR respectively and pushed forward.

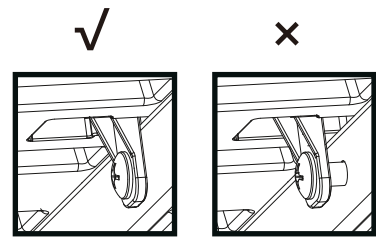
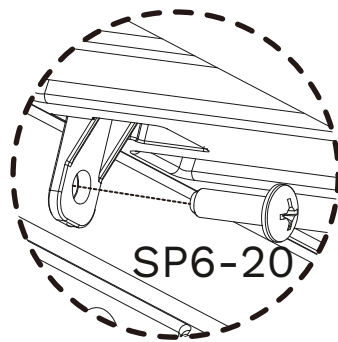
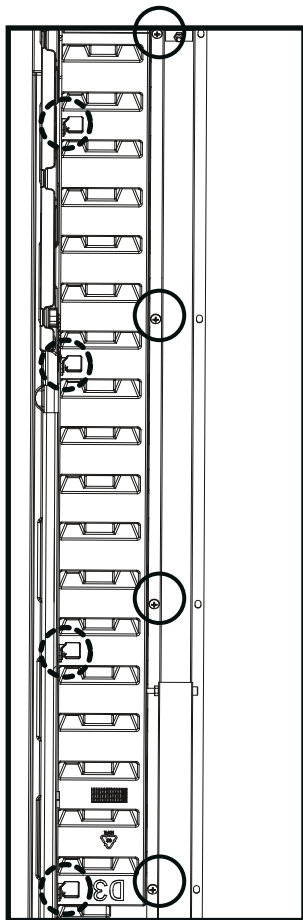

D4 should fit perfectly on the tripod.

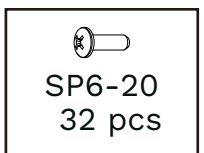
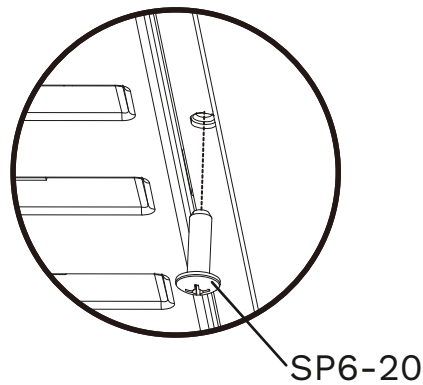

STEP 51

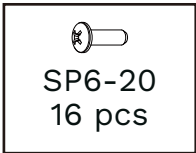
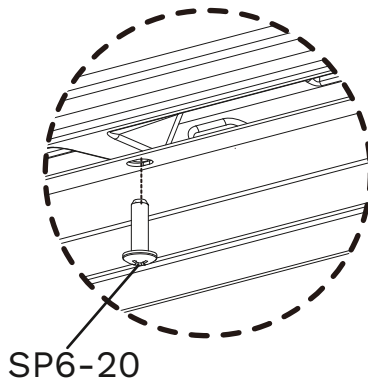
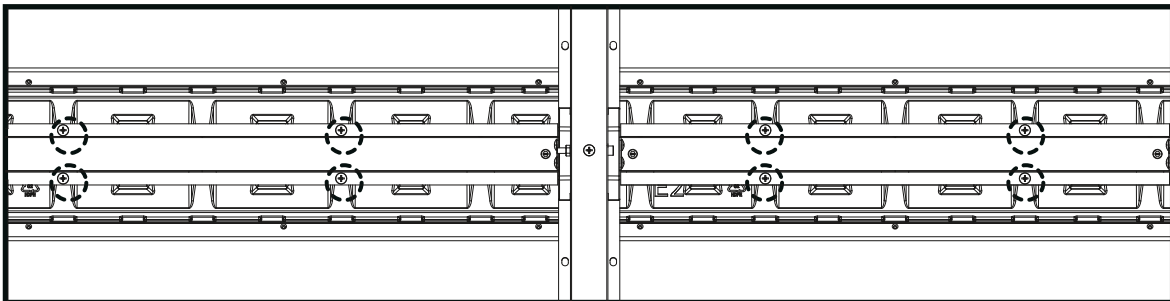
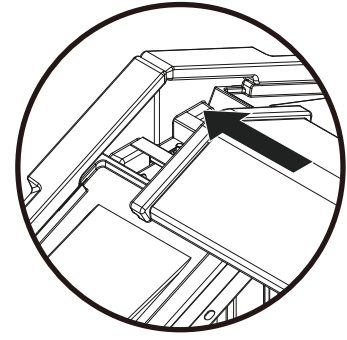
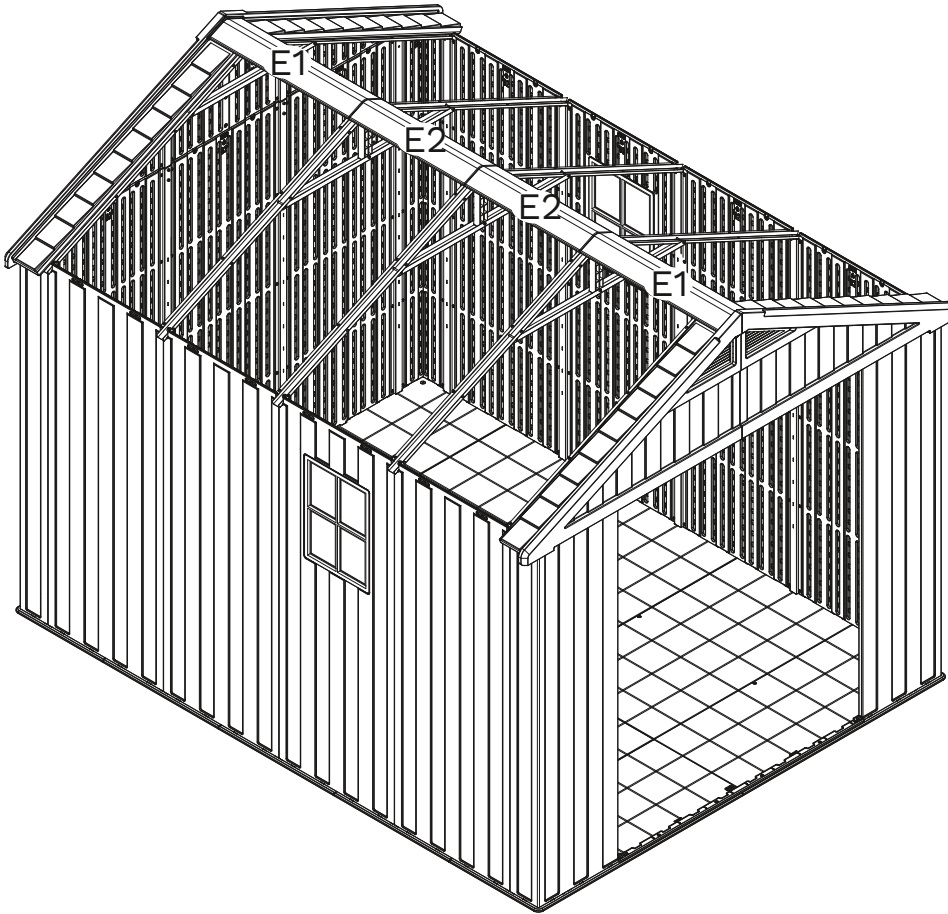

STEP 52

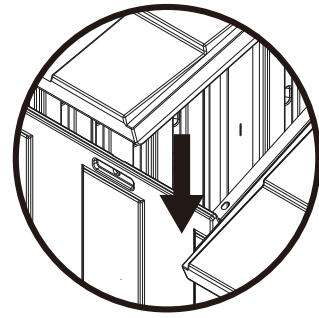
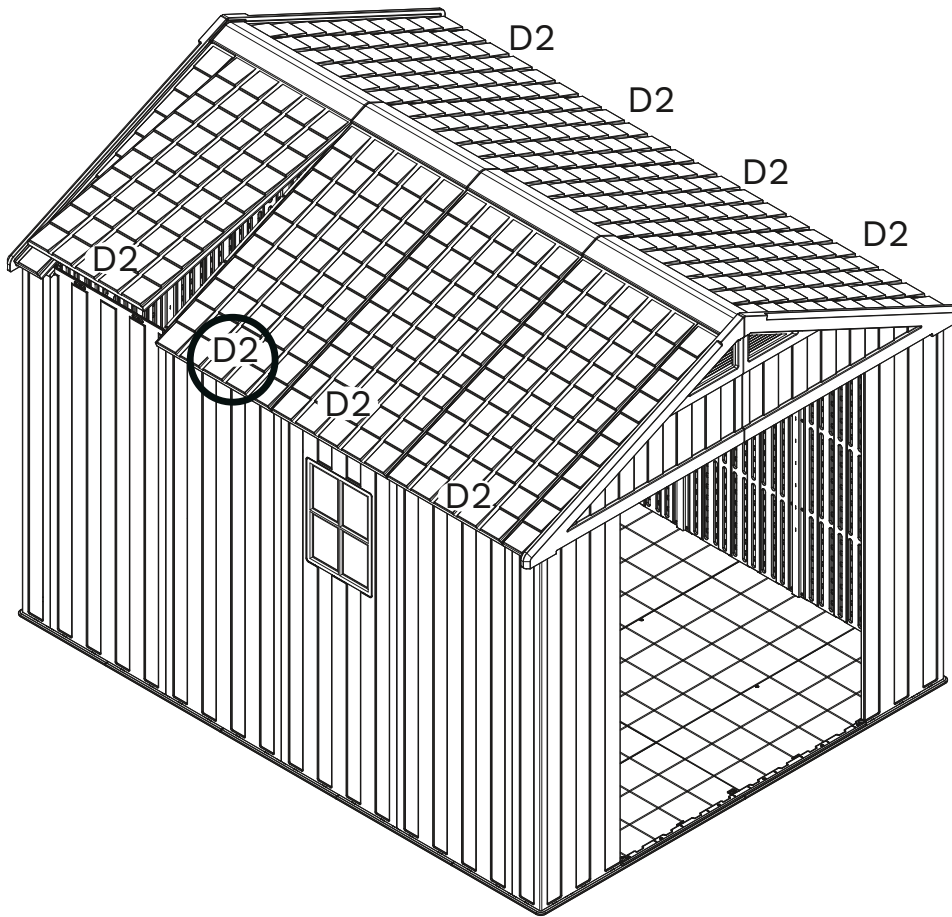

Tilt D2 into place, find the corresponding position and put it down.

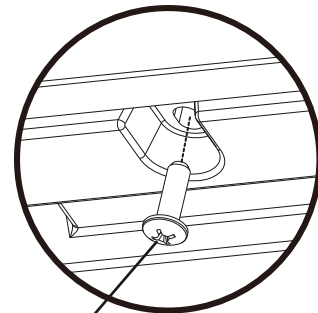
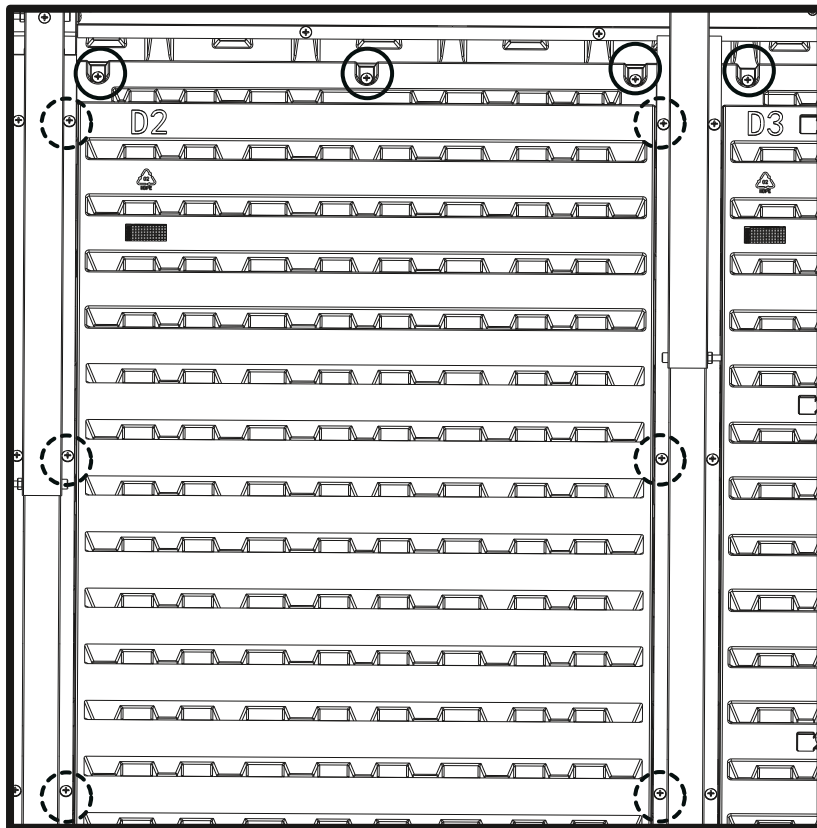

SP6-20

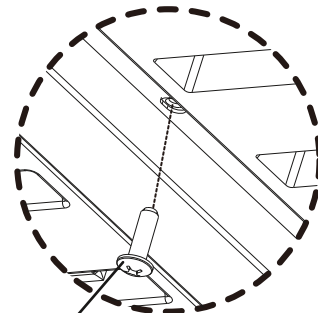

SP6-20

SP6-20
92 pcs