

PRO365ICFEPXT

PROFESSIONAL SERIES INDUCTION RANGE 36" - 5 HEATING ZONES + CAST-IRON GRIDDLE - SELF-CLEAN OVEN - STAINLESS STEEL FINISH



Exclusive Finish and Materials

Metal knobs and handles make the range a standout in every kitchen. Stainless toe-kick included with the range.

Bertazzoni signature counter-deep maintop

Bertazzoni signature stainless counter-deep maintop is designed to install flush with most kitchen countertops for a perfectly integrated look. Precise and flexible heating is provided by 5 latest generation extra-large induction zones with bridging of right-side zones. A large, removable cast-iron griddle is included.

Extra large oven with dual convection

The 5.7 cu.ft electric self-clean oven with dual diagonal convection allows even baking and roasting on 7 shelf levels. Bertazzoni ovens are equipped with an extra-large high-power broiler for broiling and grilling.

Advanced programming and controls for the oven

The elegant digital gauge gives precise control of oven temperature during pre-heating, roasting and baking, and has integrated controls for the food temperature probe. This range comes with a dedicated air-frying mode for healthier cooking, to be used with the included stainless steel mesh basket.

Best-in-class features and design

The soft-close oven door with edge-to-edge tempered glass is a masterpiece of European engineering and makes the oven door very easy to wipe clean. Convenient smooth-glide telescopic racks on 2 levels help loading and unloading the oven.

GENERAL CHARACTERISTICS

Worktop	5 induction zones
Front right	2100W (3700W booster)
Front left	1400W (2200W booster)
Center	2300W (3700W booster)
Back right	2100W (3700W booster)
Back left	2300W (3700W booster)
Knobs	Metal finish with ergonomic shape
Cooking modes	10
Tray	1 baking tray w/grill trivet + 1 air fry basket
Shelves	2 heavy duty
Levels	Laterals grids
Telescopic guides	2 sliding guides
Inner door	Squared 3 glasses
Door hinges	Soft closing
Legs	Stainless steel ø 2 3/8 inches

TECHNICAL SPECIFICATIONS

Electrical requirements	120/208 V 60HZ - 15600W 120/240 V 60HZ - 17000W 50A with dedicated circuit
Warranty	2 years parts & labor
Packaging dimensions	H:42 1/8 W:40 9/16 D:29 15/16

PRO365ICFEPXT

PROFESSIONAL SERIES INDUCTION RANGE 36" - 5 HEATING ZONES + CAST-IRON GRIDDLE - SELF-CLEAN OVEN - STAINLESS STEEL FINISH



DIMENSIONS

SIDE VIEW

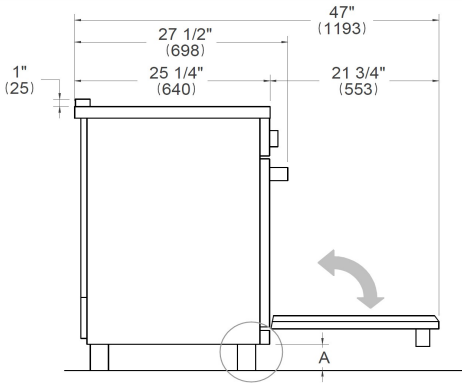

LEG DETAILS

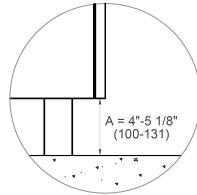

FRONT VIEW

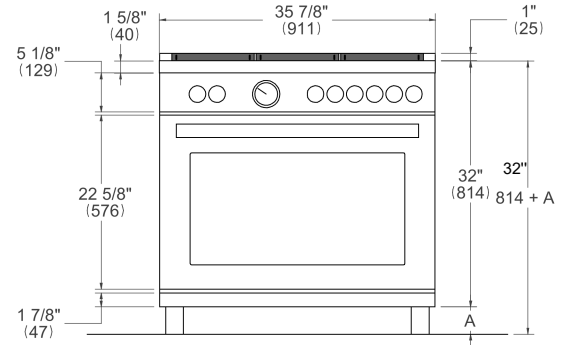

WORKTOP DETAILS

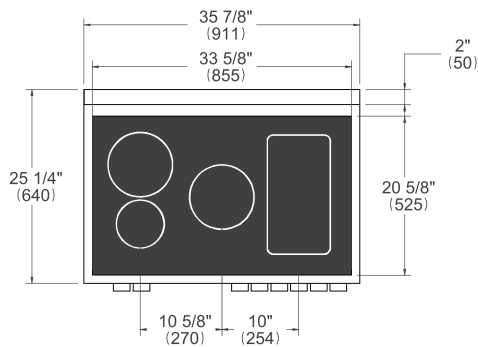

REAR VIEW

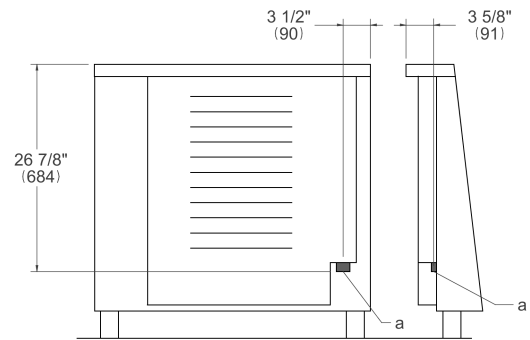

INSTALLATION

E A properly-grounded horizontally mounted electrical receptacle should be installed no higher than 3" (7.6 cm) above the floor, no less than 2" (5 cm) and no more than 8" (20,3 cm) from the left side (facing product). Check all local code requirements.

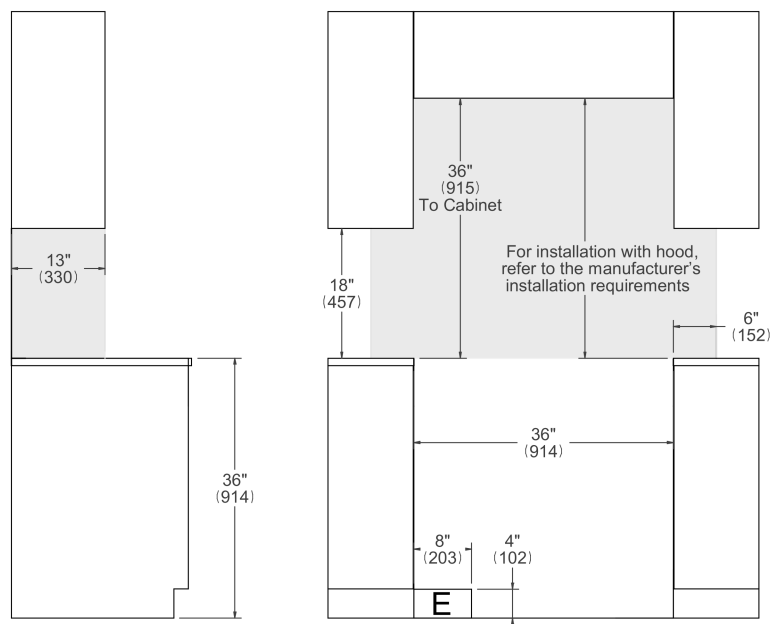

NOTE

- a. Electrical Connection
- b. Gas Connection

Disclaimer: while every effort has been made to insure the accuracy of the information contained in this document, Fratelli Bertazzoni reserves the right to change any part of the information at any time without notice. For detailed installation specifications consult the installation manual. Fratelli Bertazzoni, Bertazzoni and the winged wheel brand icon are registered trademarks of Bertazzoni Spa.