

DINING TABLE

ASSEMBLY GUIDE

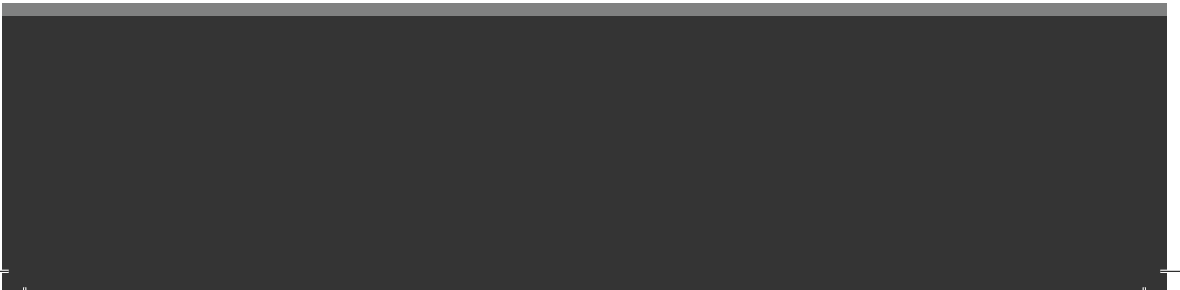

Important - Please read these instructions fully before starting assembly

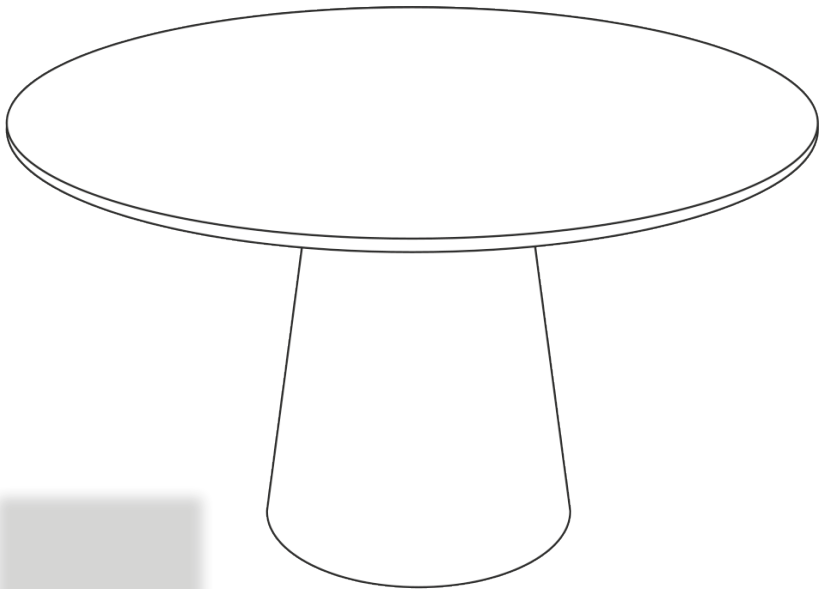

**SAFETY AND
CARE ADVICE**



NO POWER TOOLS

SAFETY AND CARE ADVICE

- Check you have all the components and tools listed.
- Remove all fittings from the plastic bags and separate them into their groups.
- We do not recommend the use of power drills/drivers for inserting screws, as this could damage the unit. Only use hand screwdrivers and Allen keys.
- Keep children and animals away from the work area, small parts could cause choking if swallowed.
- Make sure you have enough space to layout the parts before starting.
- Assemble the item as close to its final position (in the same room) as possible.
- Do not overtighten the nuts to avoid causing damage to the threads.
- Only clean using a damp cloth and mild detergent, do not use bleach or abrasive cleaners.
- From time to time check that there are no loose screws on this unit
- This product should not be discarded with household waste. Take to your local authority waste disposal centre

IMPORTANT INFORMATION



30 MINUTE
BUILD







TWO
PERSON

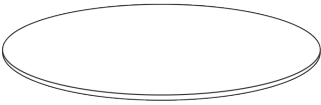

MAXIMUM
CAPACITY 100Kg

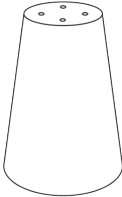
PLEASE CHECK CAREFULLY AND MAKE SURE YOU HAVE ALL FITTINGS AND TOOLS LISTED BELOW BEFORE YOU START.

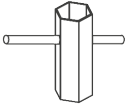
1		1pc	A		740mm	4pcs
			B		8X22mm	4pcs
2		1pc	C		M8	4pcs
			D			1pc

NOTE: The quantities above are the correct amount to complete the assembly. In some cases more fittings may be supplied than are required.

Please note, the metal rods can be found in the corner of the table base box

STEP 1

Place the table top [1] face down onto a soft, clear surface.

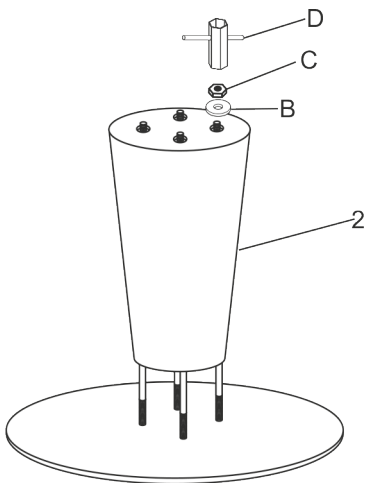
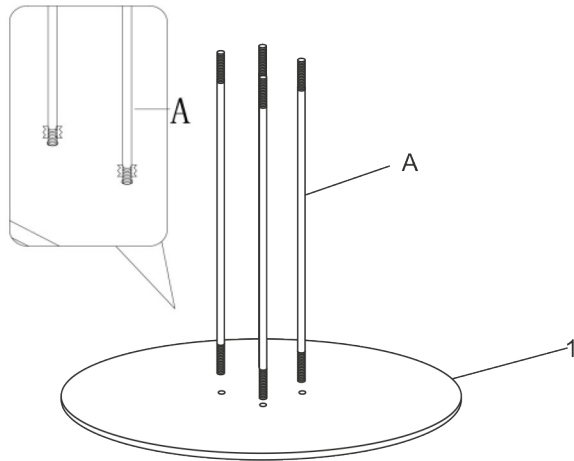

STEP 2

Place the table top [1] face down onto a soft, clear surface.

Place the pillar [2] over the rods as shown and secure each fixing using a washer (B) and nut (C). Fully tighten the fixings using box spanner (D).

STEP 3

ATTENTION: With the help of another person, carefully turn the table over to complete assembly. Your table is now ready to use.

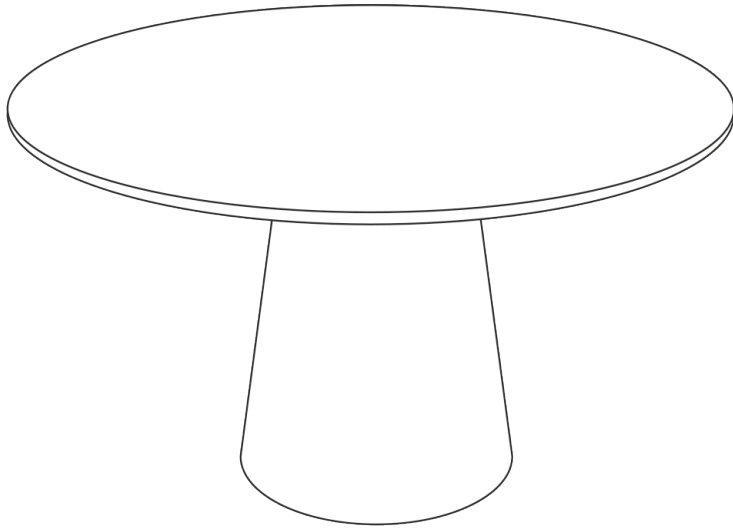



OUR 1 YEAR GUARANTEE

our products come with a 1 year guarantee to give you peace of mind shopping at



WHAT THE GUARANTEE COVERS



PRE-INSERTED FIXINGS

e.g. lose metal threads



FAULTY JOINTS

e.g. legs bending



EXTERNAL FIXING FAULTS

e.g. metal discs removing from table top



STRUCTURAL INTEGRITY

e.g. the frame of the product