

**Secretary Desk
Bureau-secrétaire
Escritorio secretarial**

TH

To receive free replacement, Control No. and Proof-of-Purchase from an authorized dealer/retailer **MUST** be provided with request within 60 days from date of purchase.

Pour obtenir un remplacement gratuit, le numéro de contrôle et la preuve d'achat auprès d'un concessionnaire/magasin autorisé **DOIVENT** être fournis avec une demande soumise dans les 60 jours suivant la date d'achat.

Para recibir un reemplazo gratis, numero de Control y prueba de compra de un comerciante/vendedor autorizado, **DEBE** ser recibido dentro de 60 días desde la fecha de compra.

IMPORTANT! Please provide **CONTROL NO.** to ensure replacement parts will properly fit unit on hand.

IMPORTANT! Fournir N° de **CONTRÔLE** pour assurer que les pièces de recharge s'adaptent correctement à l'unité en question.

IMPORTANTE! Favor de proporcionar el **NUMERO DE CONTROL** para garantizar que las piezas de reemplazo ajuste corrctame su productor.

Missing parts request:

To obtain replacement part(s), fill in quantity in the "missing" box under the "Parts List" section. Complete contact and shipping information in address box accurately and clearly. Please allow 7-14 days for delivery.

Demande de pièces manquantes:

Pour obtenir une (des) pièce(s) de remplacement, remplissez la case « manquant » sous la section « Liste des pièces ». Fournissez vos coordonnées et informations d'expédition dans la case Adresse de manière claire et précise. La livraison aura lieu dans un délai de 7 à 14 jours.

Petición de partes perdidas:

Para obtener parte(s) de reemplazo, llené en número la cantidad en el cuadro de "missing" debajo de "Lista de partes" sección. Llené su información de contacto y envío en el cuadro de dirección clara y correcta. Por favor permita 7-14 días para envío.

Name - Nom - Nombre

Address - Adresse - Dirección

City/State/Zip - Ville/Province/Code postal - Ciudad/Estado/Zona Postal

Phone - Téléphone - Teléfono

Email

Reason of replacement part(s)

Raison de(s) pièce(s) de remplacement - Razón del reemplazo la parte(s):

- Missing/Manquant/Ausente Not Fit/Ne rentre pas/No ajusta
 Damaged/Endommagé/Dañado Other/Autre/Otro:

Provide Details/Fournis détails/Proporcionar detalles:

Parts List - Liste des pièces - Lista de partes

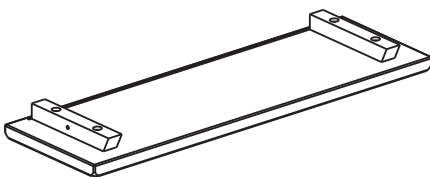

A	Table Top Plateau Superficie de la mesa	Quantity Quantité Cantidad	1	Replace Remplacer Reemplazar	
----------	---	----------------------------------	---	------------------------------------	--

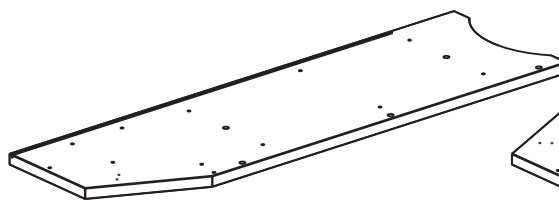

B	Left Panel Panneau gauche Panel izquierdo	Quantity Quantité Cantidad	1	Replace Remplacer Reemplazar	
----------	---	----------------------------------	---	------------------------------------	--

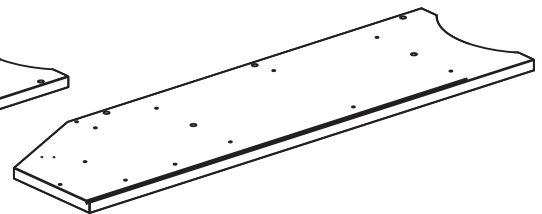

C	Right Panel Panneau droit Panel derecho	Quantity Quantité Cantidad	1	Replace Remplacer Reemplazar	
----------	---	----------------------------------	---	------------------------------------	--

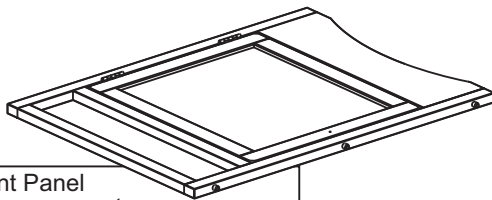

D	Front Panel Panneau avant Panel delantero	Quantity Quantité Cantidad	1	Replace Remplacer Reemplazar	
----------	---	----------------------------------	---	------------------------------------	--

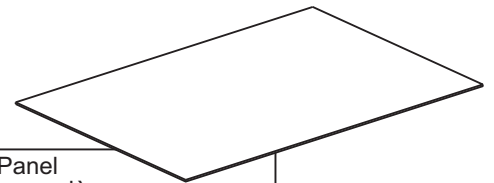

E	Back Panel Panneau arrière Panel trasero	Quantity Quantité Cantidad	1	Replace Remplacer Reemplazar	
----------	--	----------------------------------	---	------------------------------------	--

Care instructions:

To clean, wipe with wet cloth and dry thoroughly. Use mild soap if necessary. Avoid use of commercial waxes or polishes or abrasive cleaning materials.

Instructions d'entretien:

Pour nettoyer, essuyez avec un linge humide et séchez à fond. Utilisez un savon doux au besoin. Évitez d'utiliser des cires ou produits à polir de type commercial ou des matériaux de nettoyage abrasifs.

Instrucciones para el cuidado:

Para limpiar, frótelo con algo húmedo y séquelo bien. Use un jabón suave si es necesario. Evite el uso de ceras o pulidores comerciales o materiales abrasivos.

Secretary Desk
Bureau-secrétaire
Escritorio secretarial

TH

IMPORTANT! Please provide
CONTROL NO. to ensure replacement parts
will properly fit unit on hand.

IMPORTANT! Fournir N° de CONTRÔLE pour
assurer que les pièces de recharge s'adaptent
correctement à l'unité en question.

IMPORTANTE! Favor de proporcionar el
NUMERO DE CONTROL para garantizar que las
piezas de reemplazo ajuste corrctame su productor.

Name - Nom - Nombre

Address - Adresse - Dirección

City/State/Zip - Ville/Province/Code postal - Ciudad/Estado/Zona Postal

Phone - Téléphone - Teléfono

Email

Reason of replacement part(s)
Raison de(s) pièce(s) de remplacement
Razón del reemplazo la parte(s):

- Missing/Manquant/Ausente
 Damaged/Endommagé/Dañado
 Not Fit/Ne rentre pas/No ajusta
 Other/Autre/Otro:

Provide Details/Fournis détails/Proporcionar detalles:

Parts List - Liste des pièces - Lista de partes

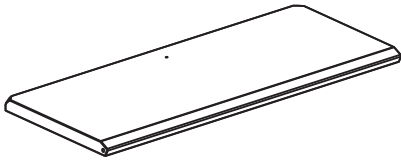

F	Pull-Down Door Abattant de porte Puerta para tirar hacia abajo		
Quantity Quantité Cantidad	1	Replace Remplacer Reemplazar	

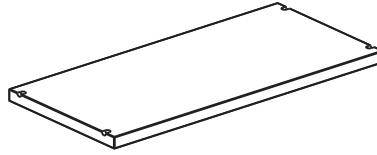

G	Large Shelf Grande tablette Repisa grande		
Quantity Quantité Cantidad	2	Replace Remplacer Reemplazar	

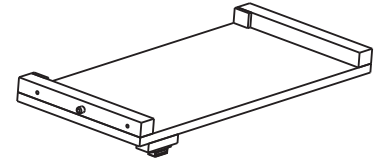

H	Middle Panel Panneau central Panel del medio		
Quantity Quantité Cantidad	1	Replace Remplacer Reemplazar	

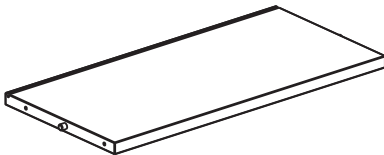

I	Bottom Panel Panneau inférieur Panel de abajo		
Quantity Quantité Cantidad	1	Replace Remplacer Reemplazar	

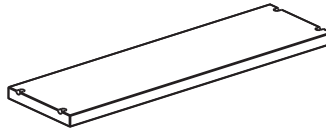

J	Small Shelf Petite tablette Repisa pequeña		
Quantity Quantité Cantidad	1	Replace Remplacer Reemplazar	

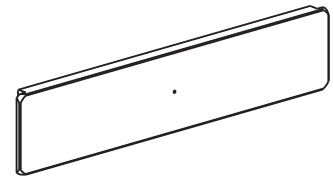

L	Front Panel (Drawer) Panneau avant (tiroir) Panel delantera (cajon)		
Quantity Quantité Cantidad	1	Replace Remplacer Reemplazar	

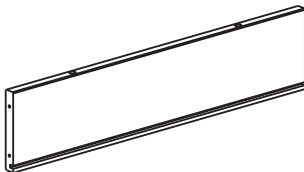

M	Back Panel (Drawer) Panneau arrière (tiroir) Panel posterior (cajon)		
Quantity Quantité Cantidad	1	Replace Remplacer Reemplazar	

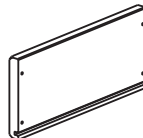

N	Side Panel (Drawer) Panneau latéral (tiroir) Panel lateral (cajon)		
Quantity Quantité Cantidad	2	Replace Remplacer Reemplazar	

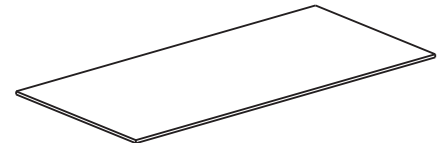

P	Bottom Board (Drawer) Panneau inférieur (tiroir) Tarjeta inferior (cajon)		
Quantity Quantité Cantidad	1	Replace Remplacer Reemplazar	

Secretary Desk
Bureau-secrétaire
Escritorio secretarial

TH

IMPORTANT! Please provide
CONTROL NO. to ensure replacement parts
will properly fit unit on hand.

IMPORTANT! Fournir N° de CONTRÔLE pour
assurer que les pièces de recharge s'adaptent
correctement à l'unité en question.

IMPORTANTE! Favor de proporcionar el
NUMERO DE CONTROL para garantizar que las
piezas de reemplazo ajuste corrcame su productor.

Name - Nom - Nombre

Address - Adresse - Dirección

City/State/Zip - Ville/Province/Code postal - Ciudad/Estado/Zona Postal

Phone - Téléphone - Teléfono

Email

Reason of replacement part(s)
Raison de(s) pièce(s) de remplacement
Razón del reemplazo la parte(s):

- Missing/Manquant/Ausente
 Damaged/Endommagé/Dañado
 Not Fit/Ne rentre pas/No ajusta
 Other/Autre/Otro:

Provide Details/Fournis détails/Proporcionar detalles:

Parts List - Liste des pièces - Lista de partes

- * **Screw Driver is required and not included in the package.**
- * **Un tournevis est nécessaire mais n'est pas inclus avec cet ensemble.**
- * **Se requiere desarmador de cruz y no viene incluido.**

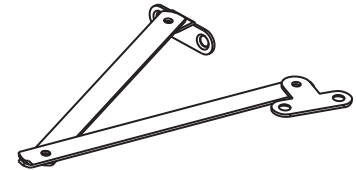
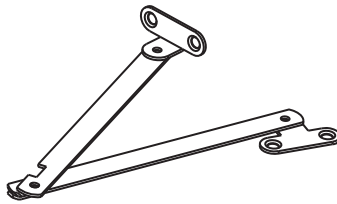

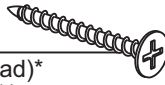
Q	Screw (flat head)* Vis (tête plate)* Tornillo (cabeza plana)*	
Quantity Quantité Cantidad	8	Replace Remplacer Reemplazar

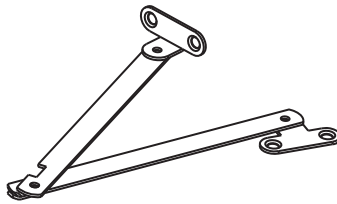
R	Arm Hinge (Left) Bra d'abattant (gauche) Brazo abisagrado (izquierda)	
Quantity Quantité Cantidad	1	Replace Remplacer Reemplazar

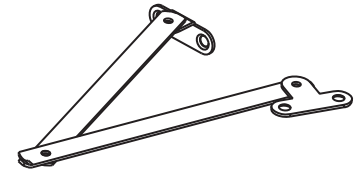
S	Arm Hinge (Right) Bra d'abattant (droit) Brazo abisagrado (derecha)	
Quantity Quantité Cantidad	1	Replace Remplacer Reemplazar

T	Metal Peg Cheville métallique Clavija de metal	
Quantity Quantité Cantidad	14	Replace Remplacer Reemplazar

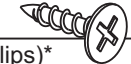
U	Small Screw (Phillips)* Petite vis (Phillips)* Tornillo pequeño (Phillips)*	
Quantity Quantité Cantidad	8	Replace Remplacer Reemplazar

V	Hex Screw Vis à tête hexagonale Tornillo hexagonal	
Quantity Quantité Cantidad	10	Replace Remplacer Reemplazar

W	Wood Plug Cheville en bois Tapón de madera	
Quantity Quantité Cantidad	10	Replace Remplacer Reemplazar

X	Loop Handle Poignée en anneau Argolla	
Quantity Quantité Cantidad	3	Replace Remplacer Reemplazar

Y	Stopper (Drawer) Bouchon (tiroir) Tapón (gaveta)	
Quantity Quantité Cantidad	2	Replace Remplacer Reemplazar

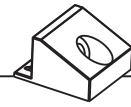

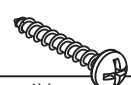
Z1	Gusset Gousset Esquinero	
Quantity Quantité Cantidad	4	Replace Remplacer Reemplazar

For Gusset Pour gousset Para esquinero		
Z2	Screw (beveled head)* Vis (tête biseautée)* Tornillo (cabeza biselada)*	
Quantity Quantité Cantidad	4	Replace Remplacer Reemplazar

	Hex Wrench Clé hexagonale Llave hexagonal	
Quantity Quantité Cantidad	1	Replace Remplacer Reemplazar

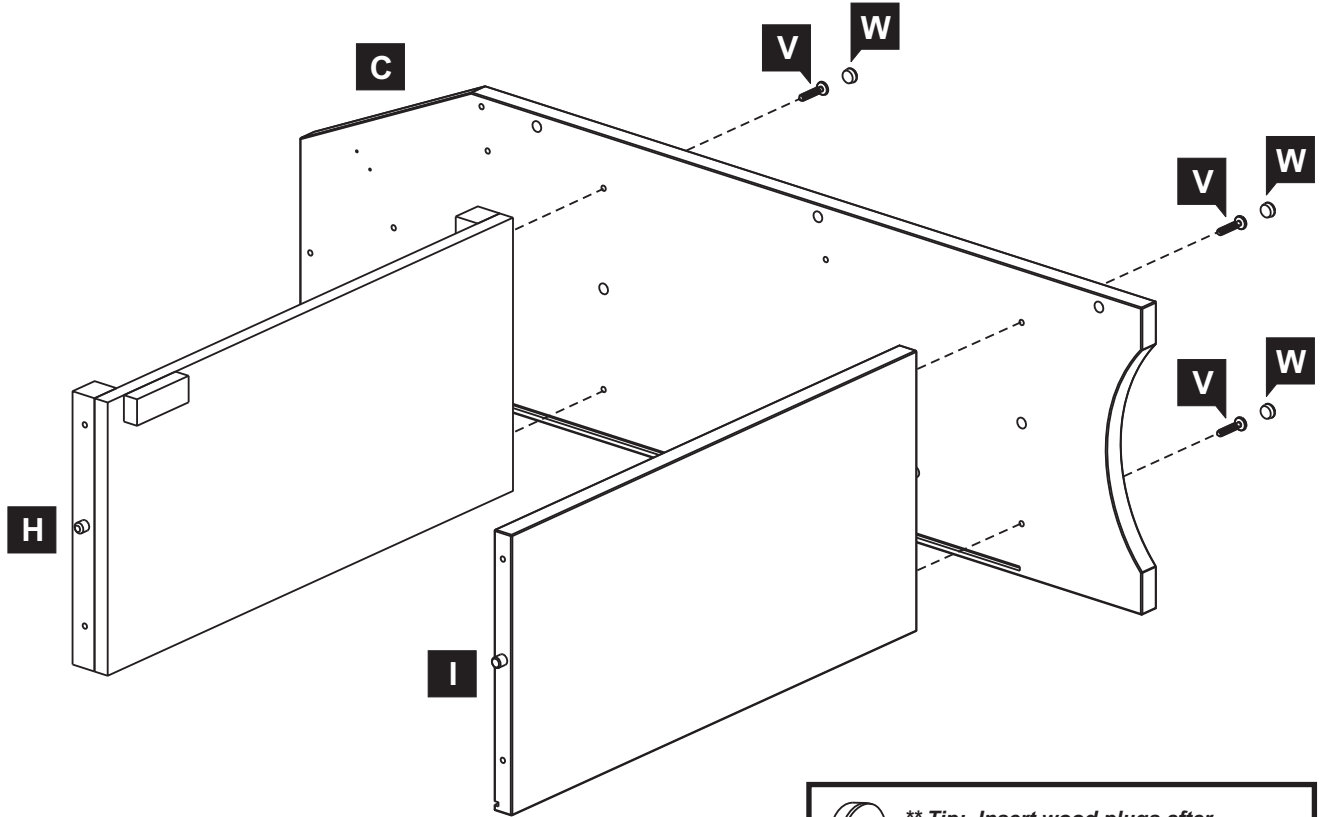
1



 ** Tip: Insert wood plugs after finishing assembling the unit.
** Conseil: fixer les tampons de bois après avoir assemblé l'unité.
 ** Consejo: ponga los taponos de madera despues de la asamblea de la unidad.

2

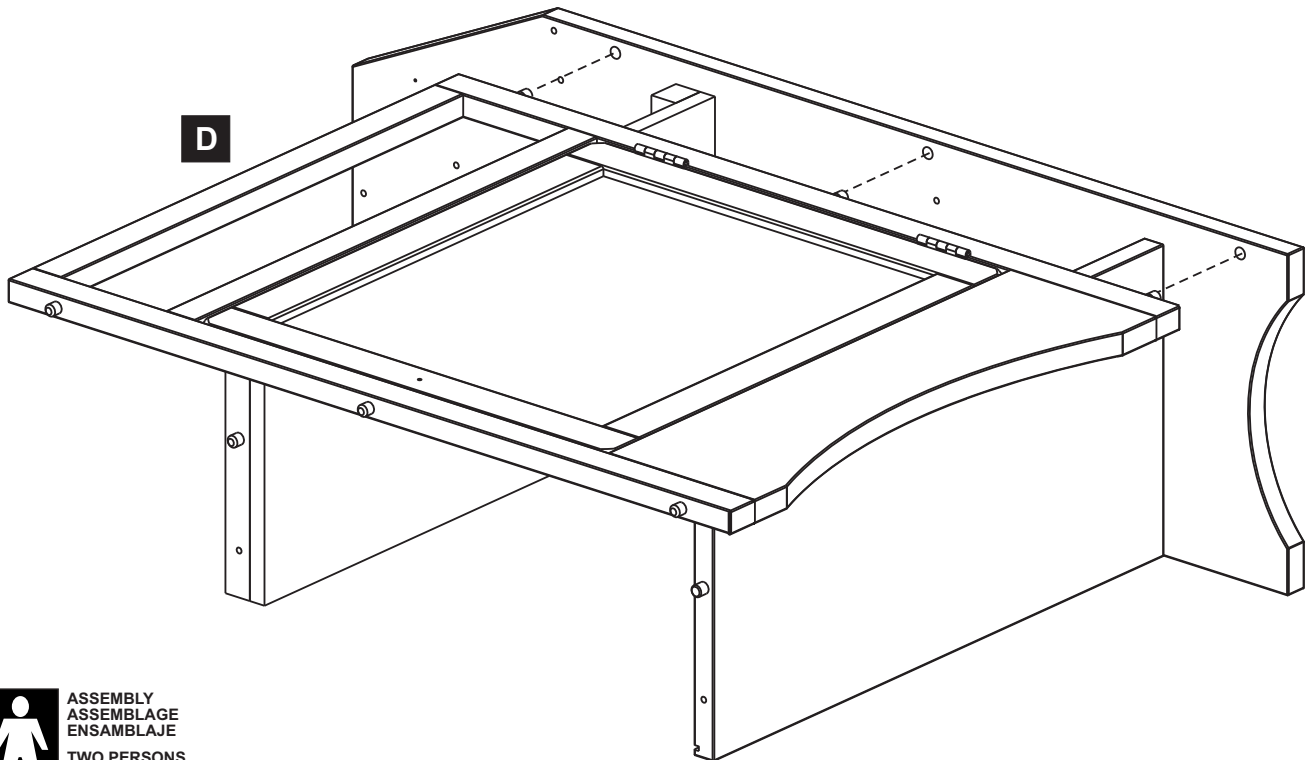

ASSEMBLY
ASSEMBLAGE
ENSAMBLAJE
TWO PERSONS
DEUX PERSONNES
DOS PERSONAS

Assembly Instructions - Instructions d'assemblage - Instrucciones de ensamblaje

3

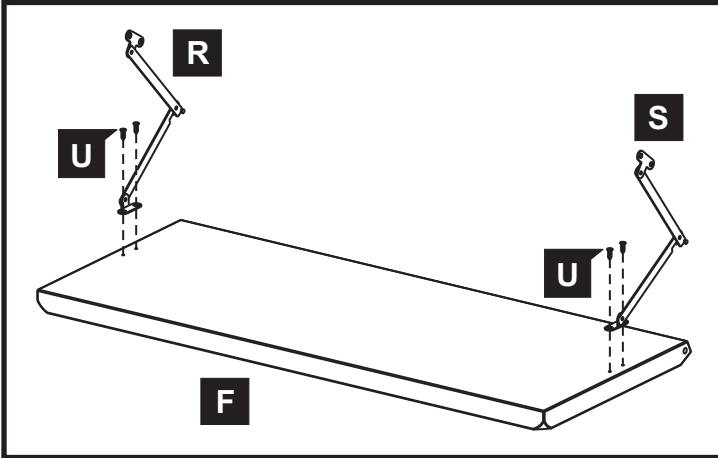

Caution:

Hold pull-down door (F) in closed position while turning unit upright.

Attention:

Maintenez la porte (F) en position fermée pendant que vous tournez le dispositif en position verticale.

Atención:

Guarde la puerta (F) en posición cerrada mientras este volteando la unidad en posición vertical.

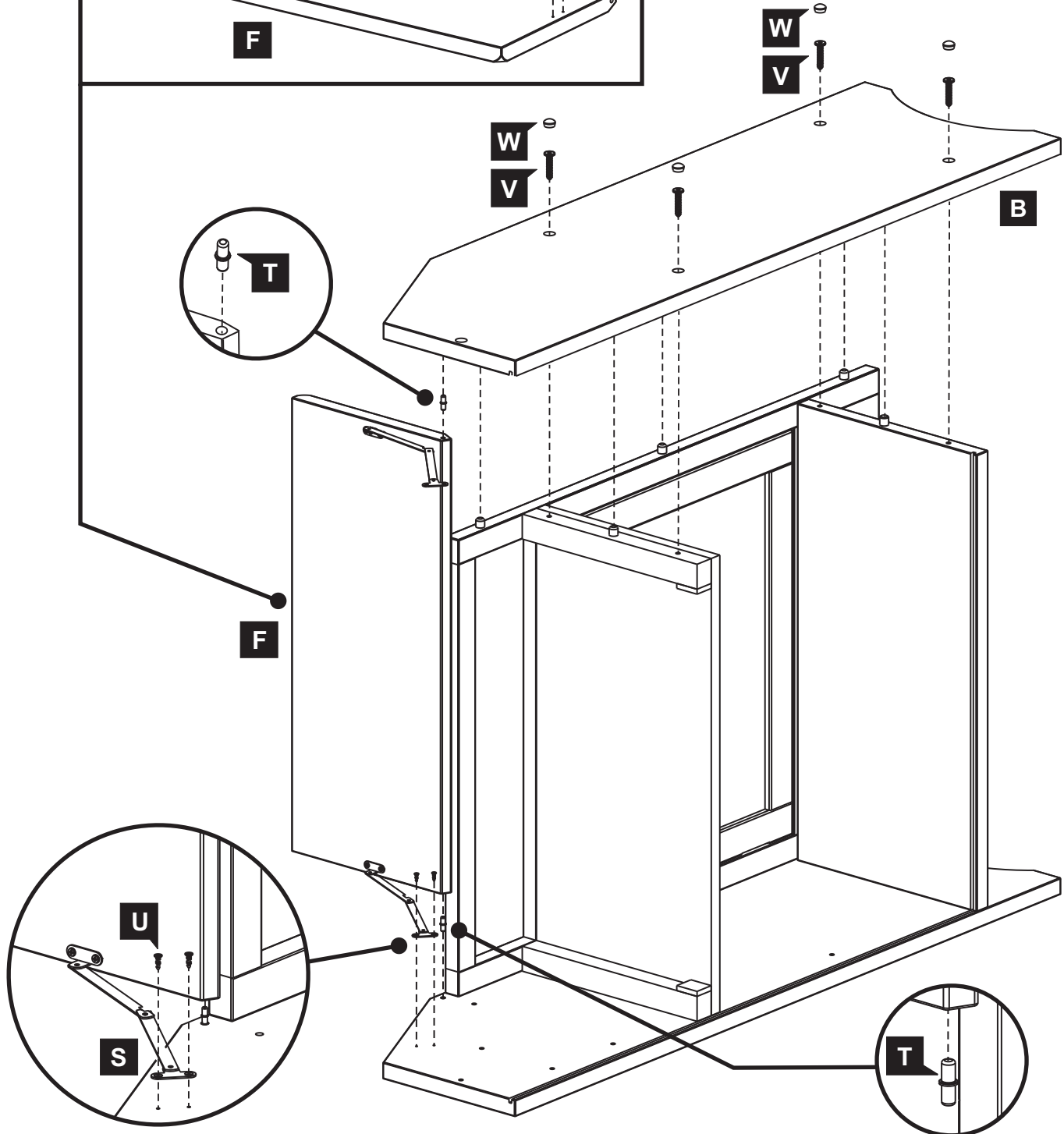

Assembly Instructions - Instructions d'assemblage - Instrucciones de ensamblaje
4
Caution:

Hold pull-down door (F) in closed position while turning unit upright. Carefully reopen door to attach hinge (Q).

Attention:

Maintenez la porte (F) en position fermée pendant que vous tournez le dispositif en position verticale. Ouvrez la porte avec précaution pour y attacher les charnières de bra (Q).

Atención:

Guarde la puerta (F) en posición cerrada mientras este volteando la unidad en posición vertical. Cuidadosamente abra la puerta para instalar labisagra (Q),

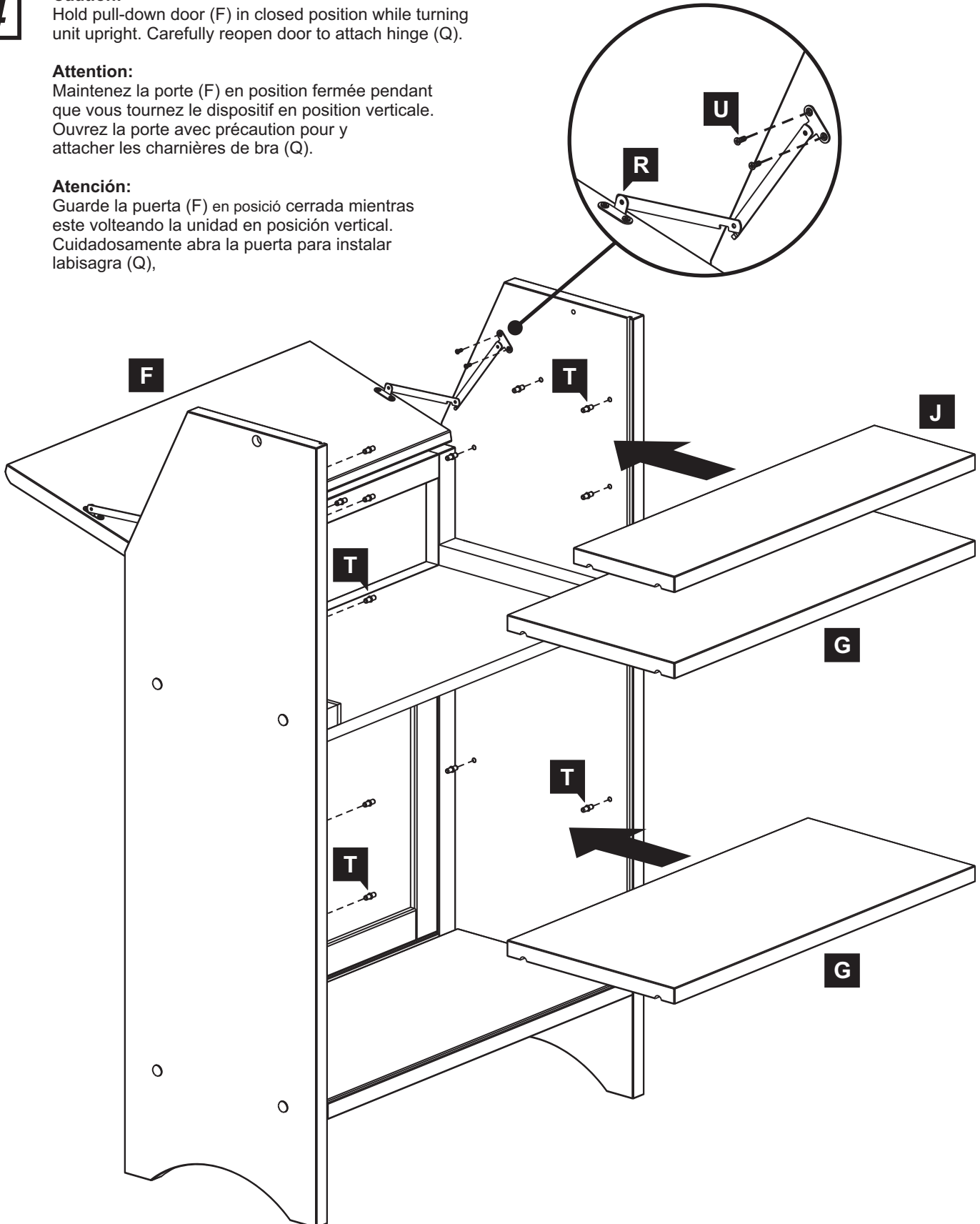

5

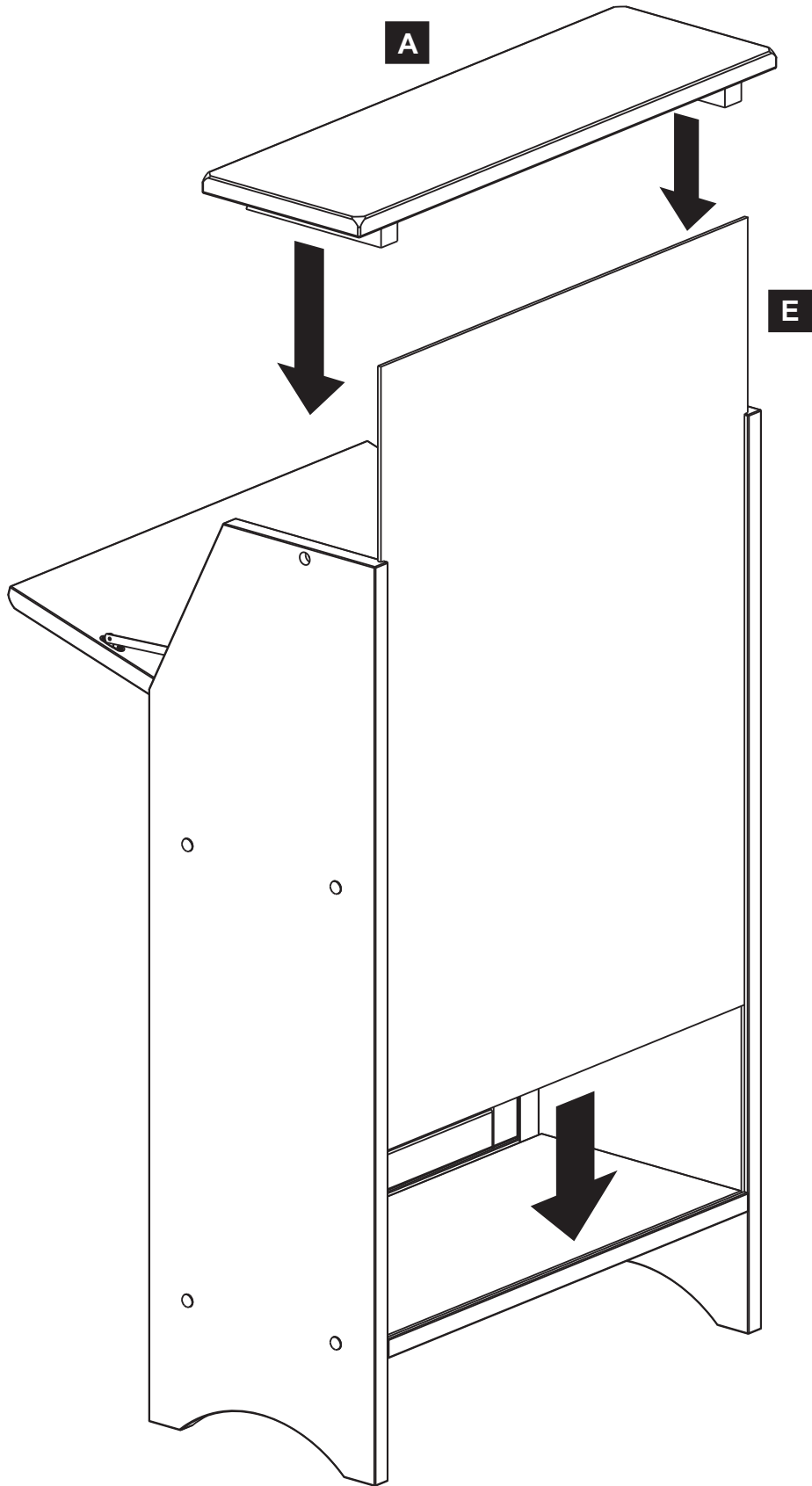

6

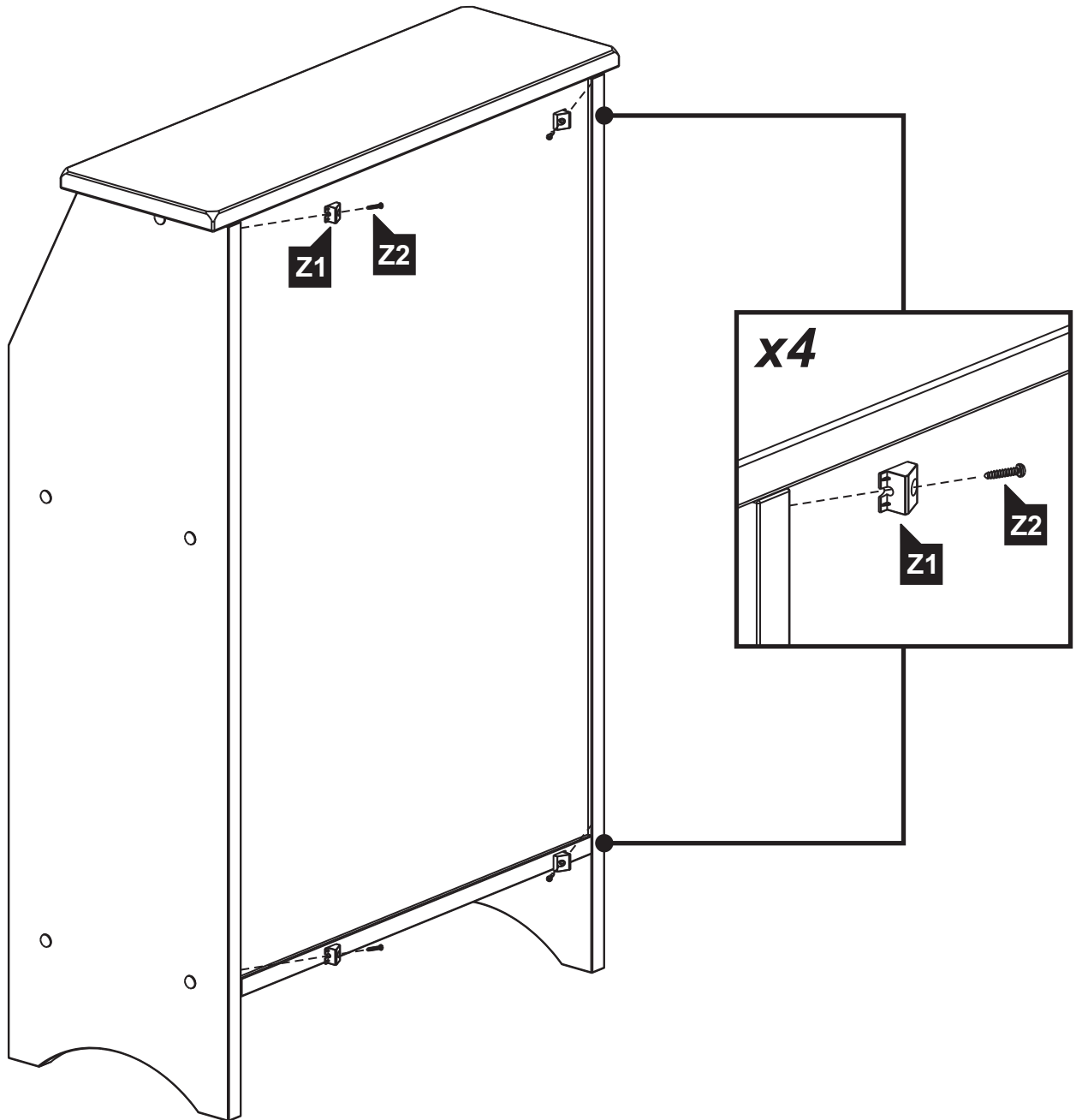

7

