

Standing Storage Cabinet

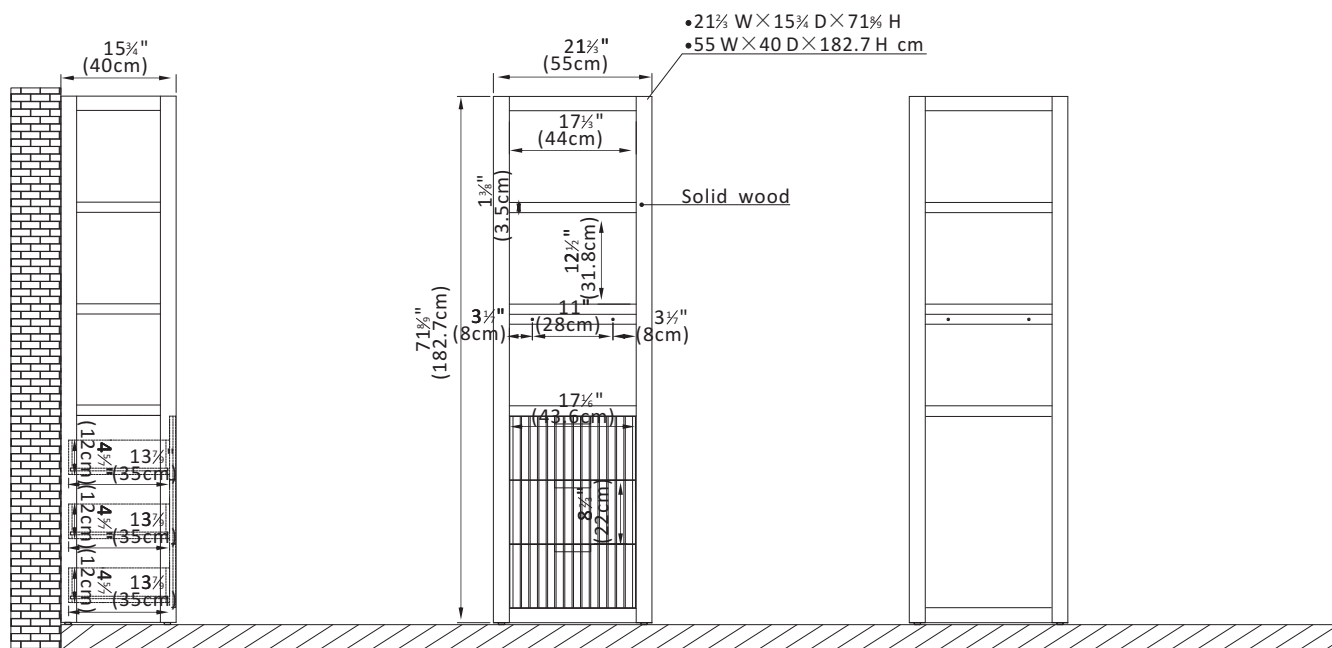

Features

- *Constructed of imported, high-quality solid oak and plywood for superior sturdiness and long-lasting beauty.
- *Stable, space-saving design is perfect for any room in the house.
- *Available in your choice of a beautiful Fir Wood Black, Fir Wood White, or Fir Wood Grey finish to complement your décor.
- *Brushed Gold or Matte Black handles provide a striking contrast against the natural grain of the wood.
- *Includes three sturdy, soft-closing dovetail drawers and three open shelves that are ideal for linens, books, or decorative accessories.
- *Easy to assemble and includes mounting hardware (Note: Please be sure to lock it).
- *1-Year Manufacturer Warranty—purchase with 100% peace of mind.

Storage Cabinet Dimensions:

Item: #704122-SCA-FB/704122-SCA-FW/704122-SCA-FY

Overall Dimensions: 21.7"W x 15.7"D x 71.9"H

Overall Product Weight: 89.1 lb.

All specifications are subject to change without prior notice.

* Does not include main vanity, faucet, drain assembly, backsplash or P-trap, comes fully assembled and ready to install in your bathroom.