

ASSEMBLY INSTRUCTION

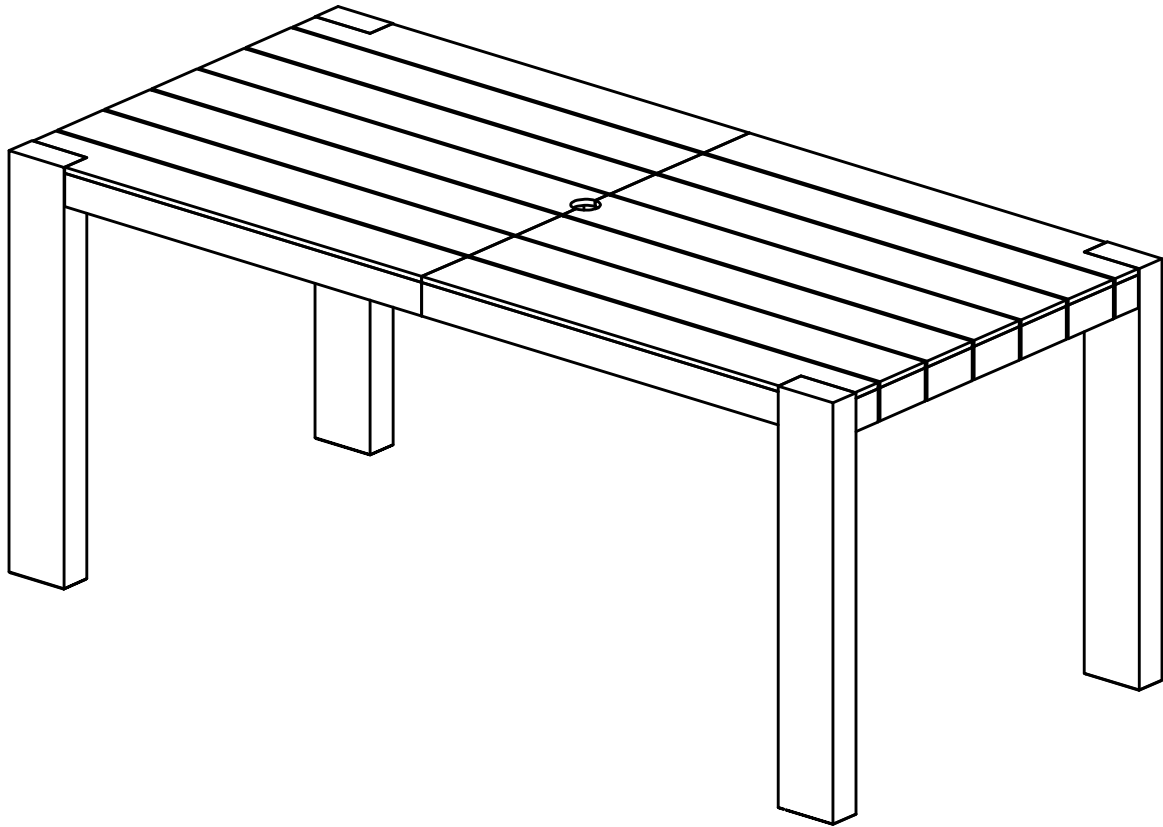

Thank you for purchasing this quality product. Be sure to check all packing material carefully for small parts which may have come loose inside the carton during shipment. Separate, identify and count all parts and hardware.

Compare with the parts list to be sure all parts are present.

"DO NOT TIGHTEN SCREWS UNTIL COMPLETELY ASSEMBLED"

Use of power tool to assemble this product will invalidate any claim and damage this product making unsafe !!! Please assemble on a clean soft surface to avoid damage

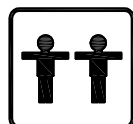
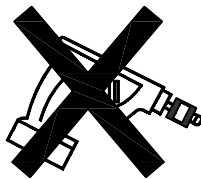

+

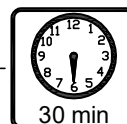

Tools Required

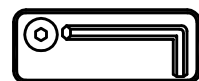

(Included)

IMPORTANT:

PLEASE READ INSTRUCTION BEFORE STARTING THE ASSEMBLY

PLEASE DO NOT RETURN TO STORE



Please do not return this product to the retailer!!
We are able to assist you in ANY way

If you find that you have any trouble with assembly or missing or damaged parts please contact the seller.

Before Installation

Important – Please read these instructions fully before starting assembly

Thank you for purchasing this quality product. Be sure to check all packing materials carefully for small parts, which may have come loose inside the carton during shipment. Identify and count all items according to the PARTS LIST and/or HARDWARE LIST shown below. Check you have all the components and tools listed on the following pages.

- We recommend that you assemble this product with the assistance of another person; this will make the assembly easier, and will help eliminate damage to the product or injury to persons during assembly.
- Please do not over tighten screws or bolts until the assembly is completed.
- Keep children and animal away from the work area, small parts could choke if swallowed.
- Please put all parts on a non-abrasive floor before assembly, and follow the assembly steps to assemble your newly purchased product correctly and efficiently.

DETAIL VIEW

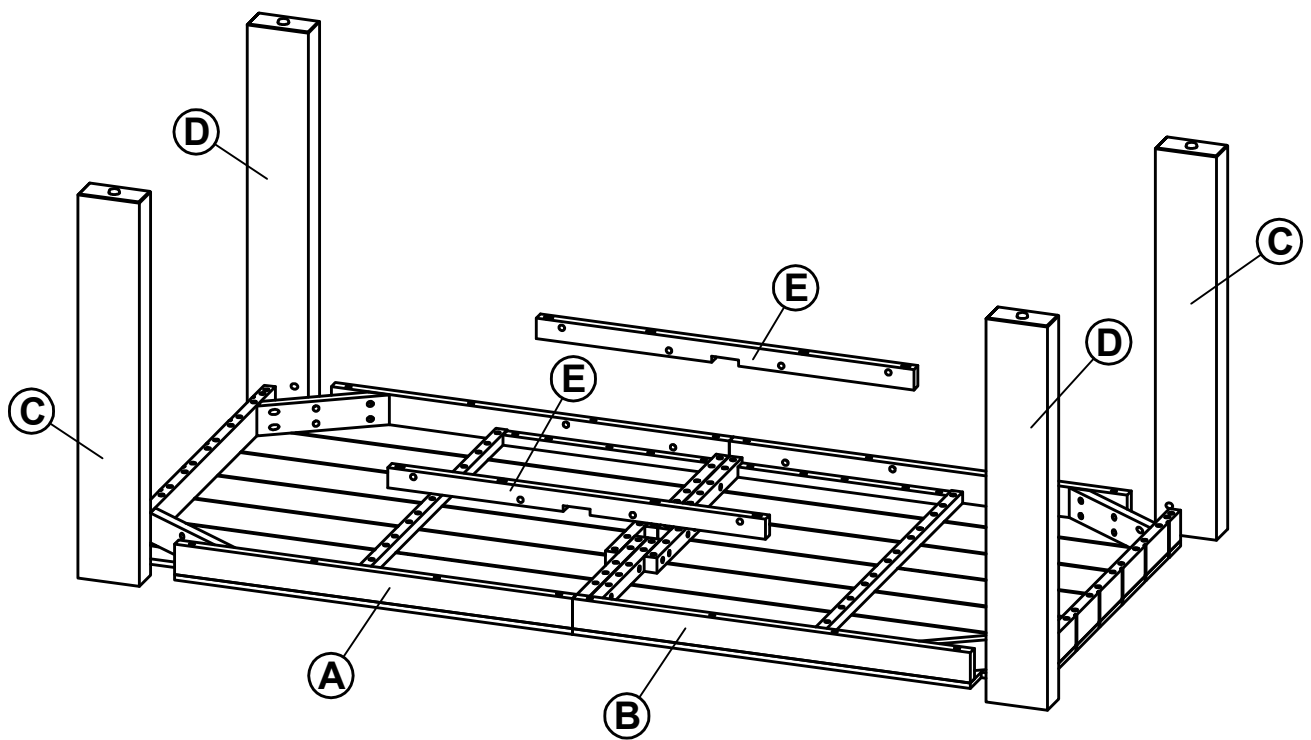

Identifying the Hardware - Identify the hardware using the illustrations below.

PART LIST

A

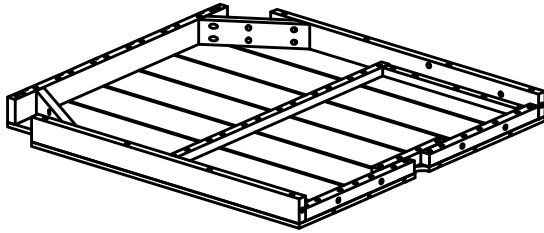

TABLE TOP 1 = 1 PC

B

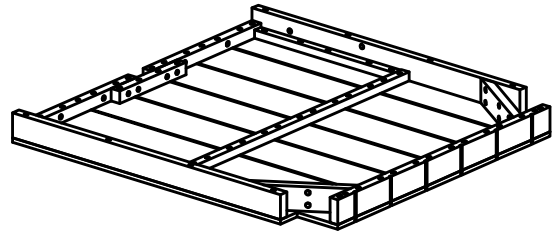
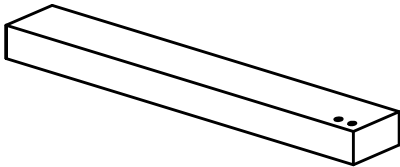

TABLE TOP 2 = 1 PC

C



LEFT LEG = 2 PCS

D

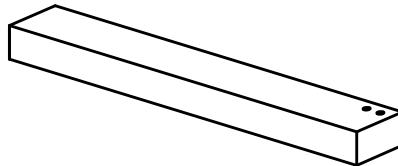

RIGHT LEG = 2 PCS

E

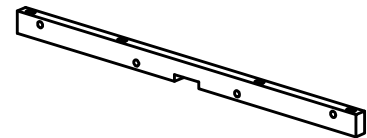

SUPPORT BAR = 2 PCS

HARDWARE LIST

1. BOLT



M8 x 60 mm = 8PCS

2. BOLT



M8 x 50 mm = 12PCS

3. BOLT



M8 x 40 mm = 8PCS

4. SPRING WASHER



Ø8 x 13 mm = 8PCS

5. FLAT WASHER



Ø8 x 18 mm = 20PCS

6. DOWEL



Ø10 x 30 mm = 2PCS

7. Allen Wrench



4 x 60 mm = 1PC

STEP 1

6



2 PCS

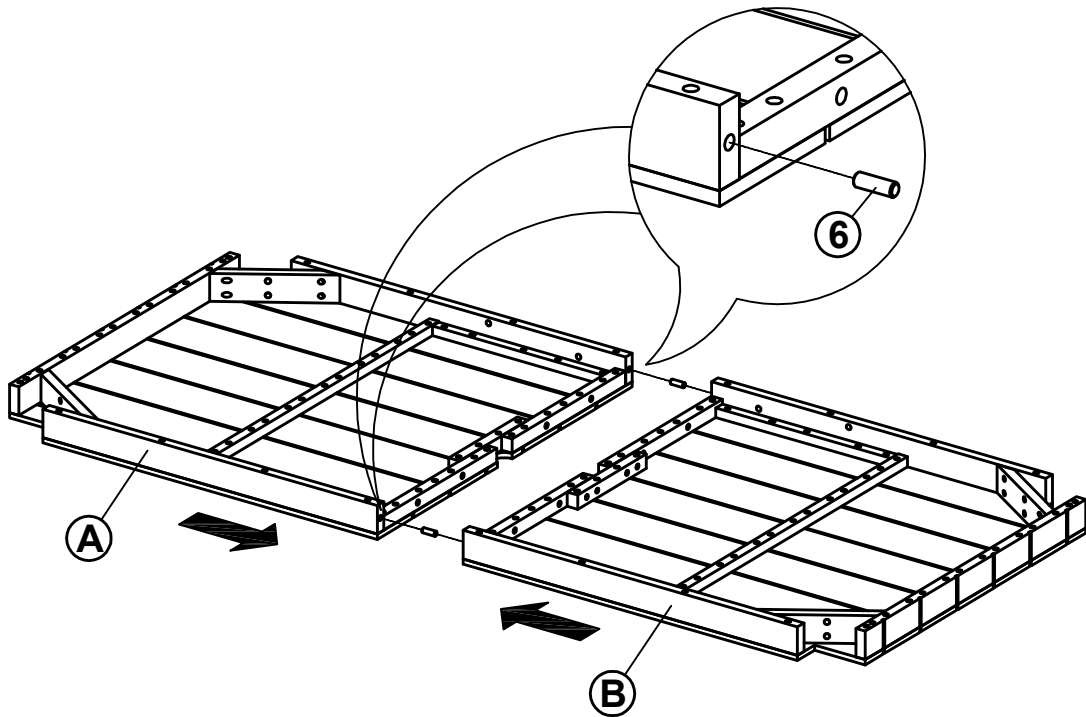

STEP 2

2



4 PCS

5



4 PCS

7



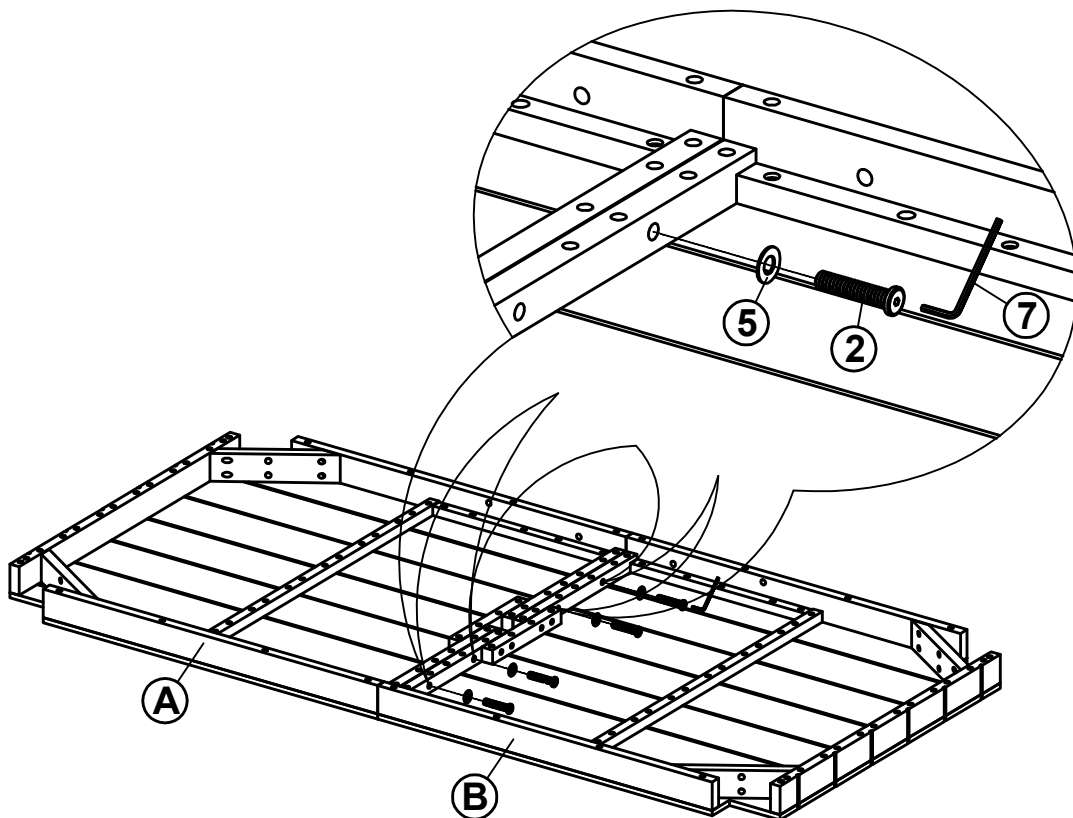

1 PC

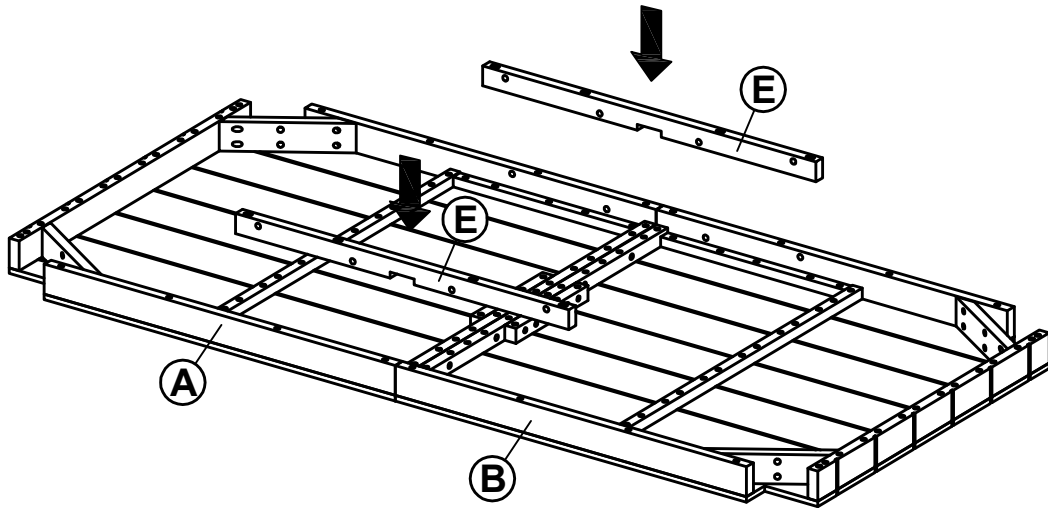

STEP 3



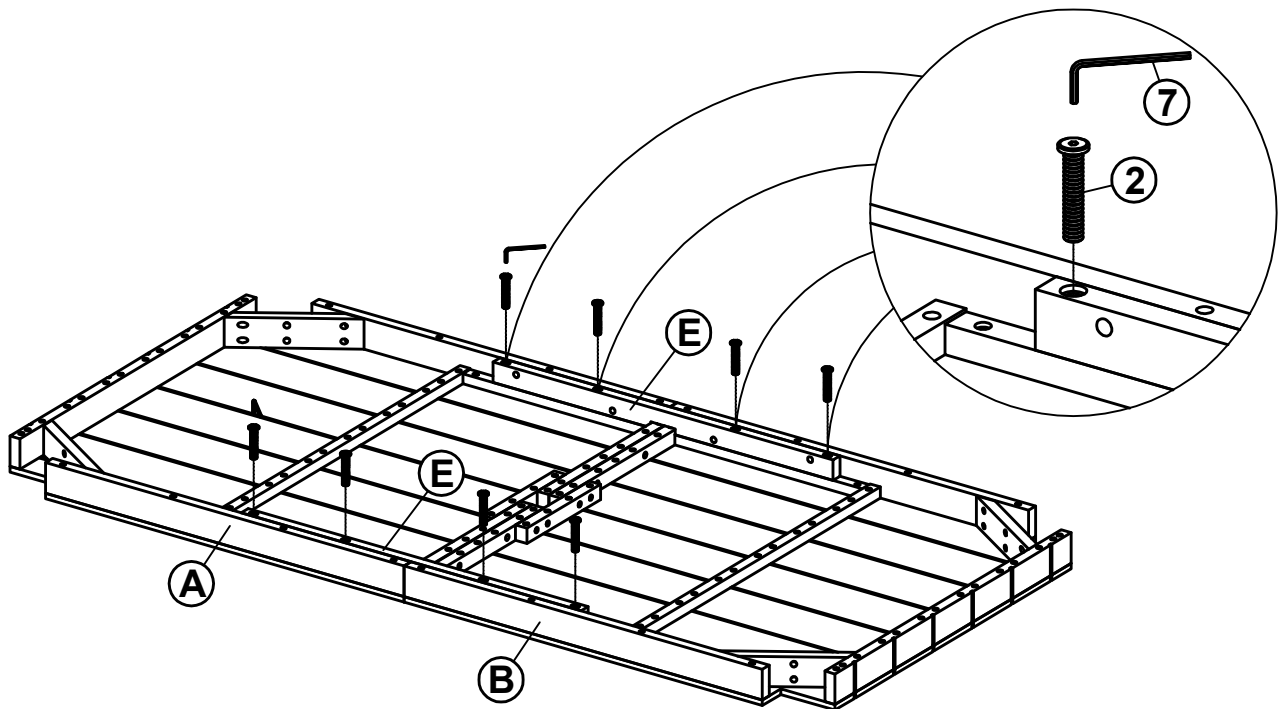

STEP 4

2		7	
8 PCS		1 PC	





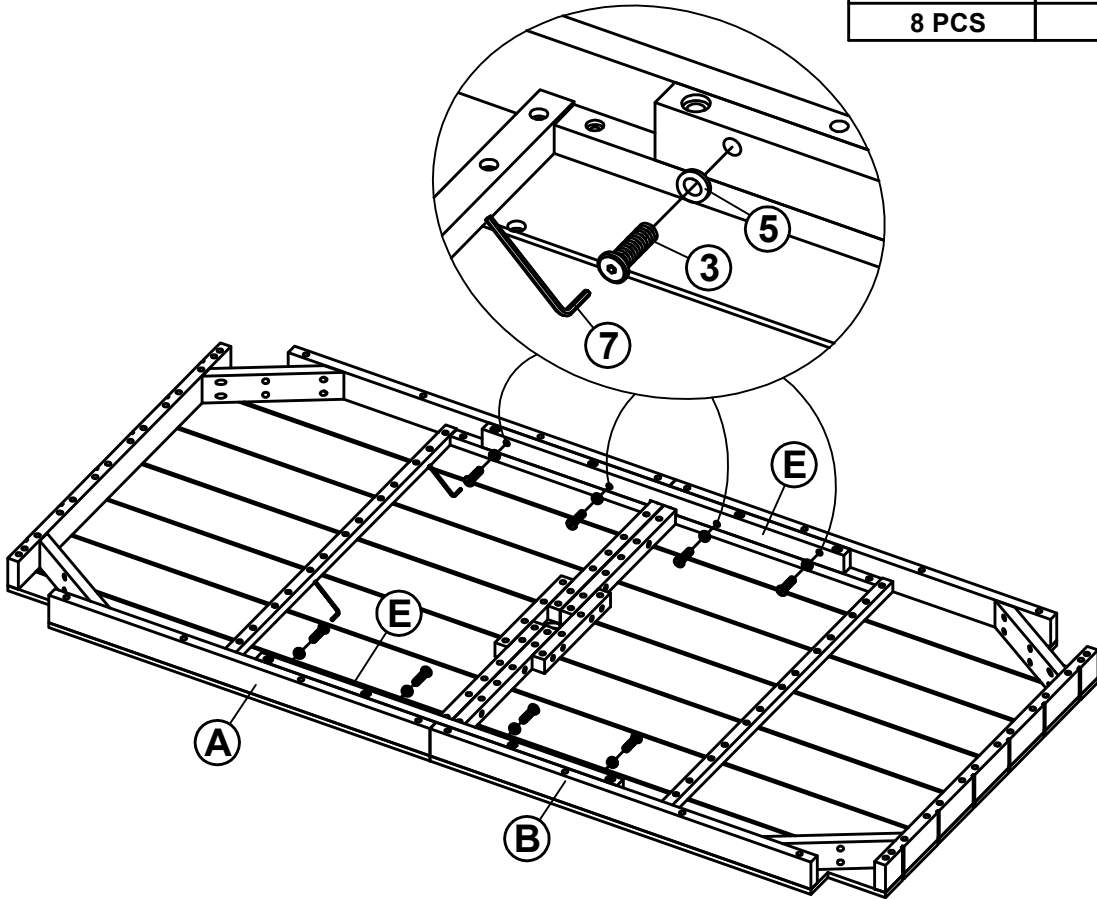

STEP 5

3		5		7	
	8 PCS		8 PCS		1 PC



STEP 6

1		4		5		7	
	8 PCS		8 PCS		8 PCS		1 PC

