

ASSEMBLY INSTRUCTIONS



Fine Furniture for every stage of life

Dining Table

ASSEMBLY INSTRUCTIONS

ASSEMBLY TIPS :

1. Remove hardware from box and sort by size.
2. Please check to see that all hardware and parts are present prior to start of assembly.
3. Please follow attached instructions in the same sequence as numbered to assure fast & easy assembly.

WARNING !



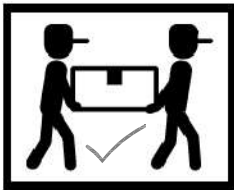

1. Don't attempt to repair or modify parts that are broken or defective. Please contact the store immediately.
2. This product is for home use only and not intended for commercial establishments.





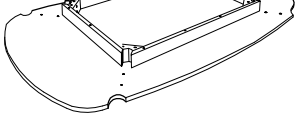

ASSEMBLY TIME

15 MINUTES

PARTS IDENTIFICATION

A	TOP		1PC
B	LEG		4PCS

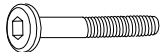
HARDWARE IDENTIFICATION

1	ALLEN WRENCH (M4 x 110mm - BLK)		1PC
2	HEX HEAD SCREW (M6.5 x 70mm - RBW)		8PCS
3	BOLT (M6 x 60mm - RBW)		8PCS
4	LOCK WASHER (1/4" - BLK)		16PCS
5	SMALL FLAT WASHER (M6 x 13mm - RBW)		8PCS
6	BIG FLAT WASHER (1/4" - RBW)		8PCS

NOTE :

Phillips head screw driver is required in the assembly process ; However, manufacturer not provide this item.

ASSEMBLY INSTRUCTIONS

STEP 1

ATTENTION! PLEASE REMOVE ALL SCREWS AND WOOD BLOCKS BEFORE ASSEMBLE.

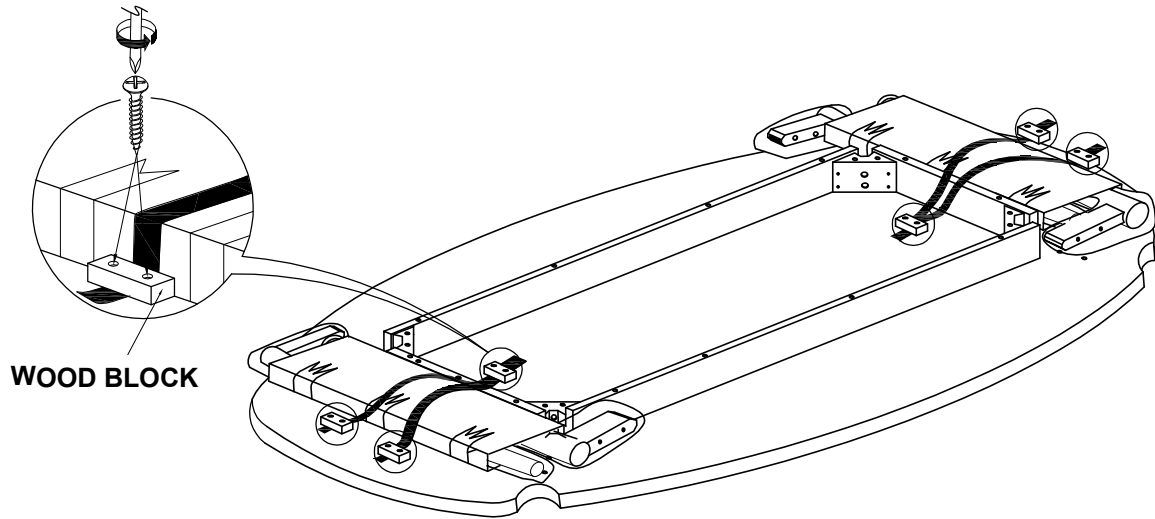

STEP 2

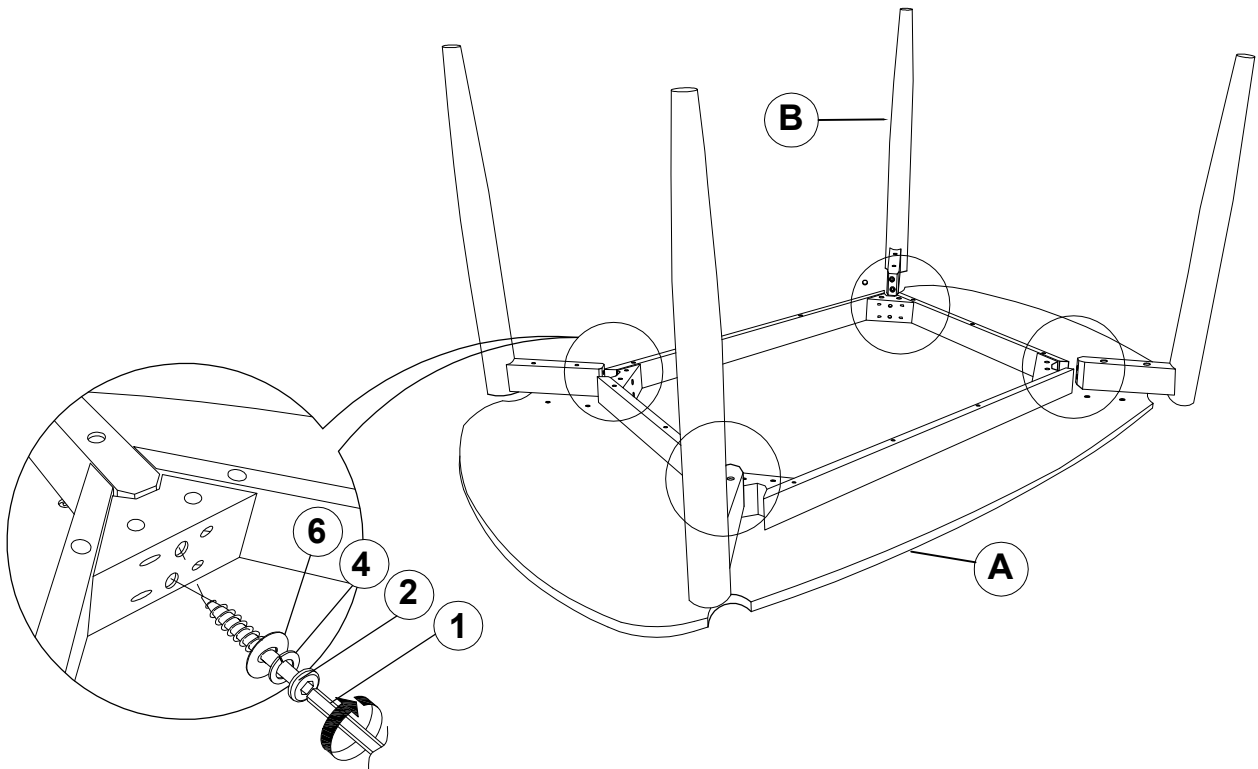

ASSEMBLY INSTRUCTIONS

STEP 3

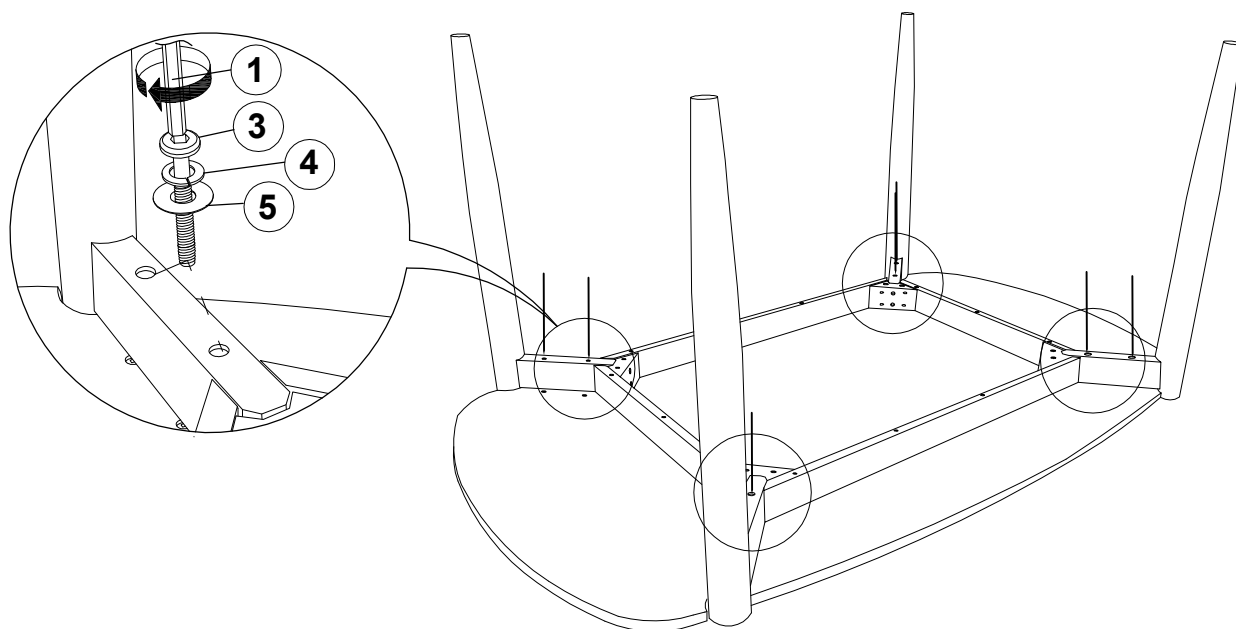

STEP 4

COMPLETE

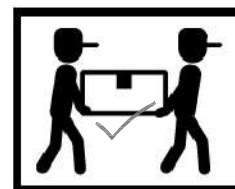

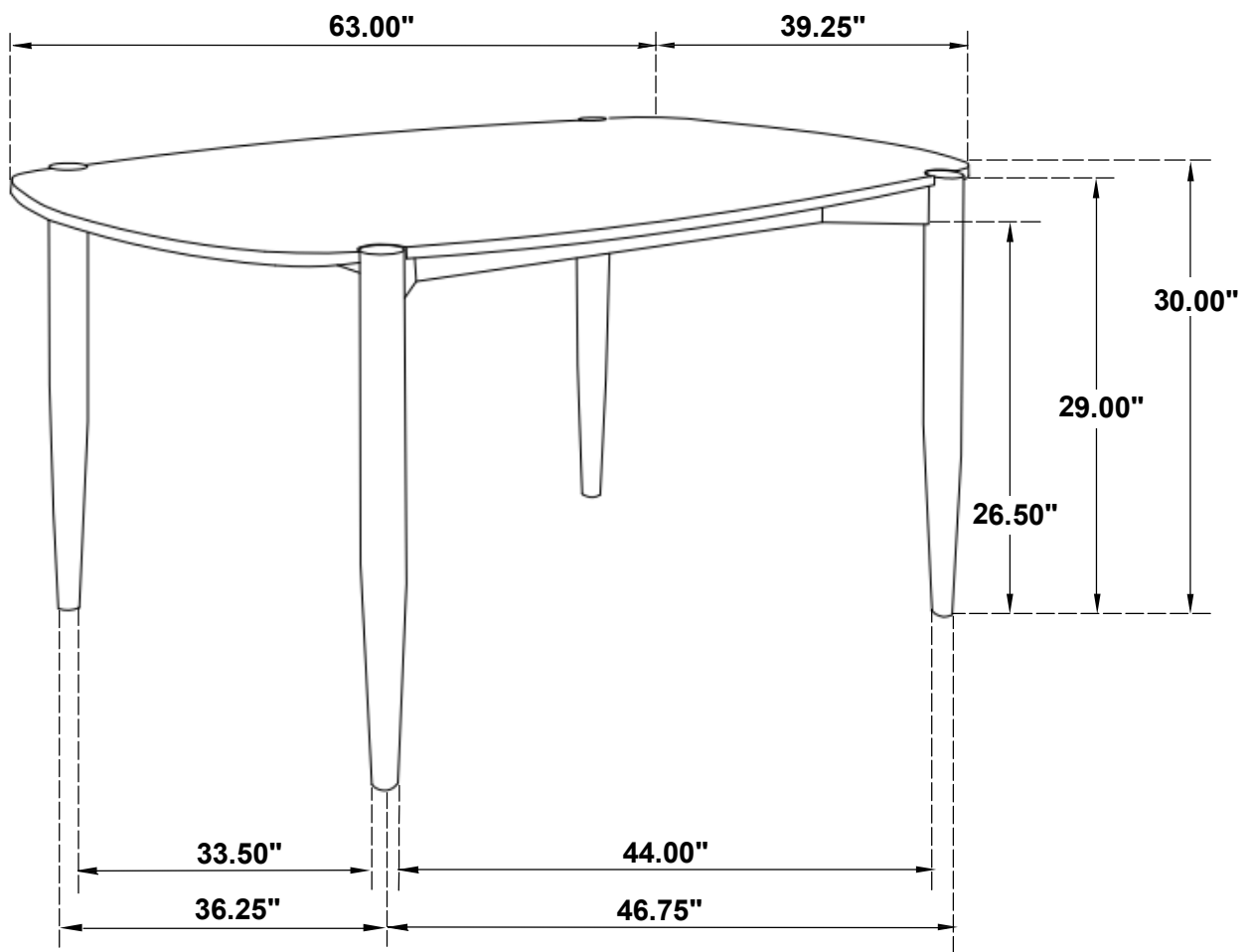

Note: Dimension tolerance $\pm 5\%$

ASSEMBLY INSTRUCTIONS



Fine Furniture for every stage of life

Side Chair

ASSEMBLY INSTRUCTIONS

ASSEMBLY TIPS :

1. Remove hardware from box and sort by size.
2. Please check to see that all hardware and parts are present prior to start of assembly.
3. Please follow attached instructions in the same sequence as numbered to assure fast & easy assembly.



WARNING !



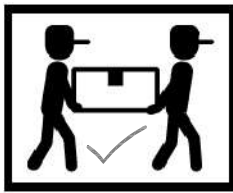



1. Don't attempt to repair or modify parts that are broken or defective. Please contact the store immediately.
2. This product is for home use only and not intended for commercial establishments.

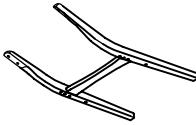
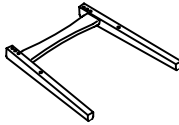

ASSEMBLY TIME

15 MINUTES

PARTS IDENTIFICATION

A	BACKREST		1PC
B	BACK LEG FRAME		1PC
C	FRONT LEG FRAME		1PC
D	RIGHT SIDE RAIL		1PC
E	LEFT SIDE RAIL		1PC
F	RIGHT SIDE STRETCHER		1PC
G	LEFT SIDE STRETCHER		1PC
H	SEAT CUSHION		1PC

ASSEMBLY INSTRUCTIONS

ASSEMBLY TIPS :







1. Remove hardware from box and sort by size.
2. Please check to see that all hardware and parts are present prior to start of assembly.
3. Please follow attached instructions in the same sequence as numbered to assure fast & easy assembly.

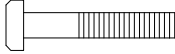
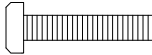

WARNING !

1. Don't attempt to repair or modify parts that are broken or defective. Please contact the store immediately.
2. This product is for home use only and not intended for commercial establishments.

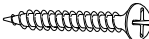
HARDWARE IDENTIFICATION

1	ALLEN WRENCH (M4 x 110MM - BLK)		1PC
2	LONG BOLT (M6 x 50MM - RBW)		4PCS
3	SHORT BOLT (M6 x 30MM - RBW)		4PCS
4	LOCK WASHER (1/4" - BLK)		8PCS
5	FLAT WASHER (M6 X 13MM - RBW)		8PCS
6	SHORT PAN HEAD SCREW (#8 X 1 1/4")		4PCS
7	LONG PAN HEAD SCREW (#8 X 1 1/2")		4PCS
8	WOOD PLUG (Ø14.5 X 9MM)		4PCS

NOTE :

Quantities shown are for one chair.
Phillips head screw driver is required in the assembly process ; However, manufacturer not provide this item.

ASSEMBLY INSTRUCTIONS

STEP 1

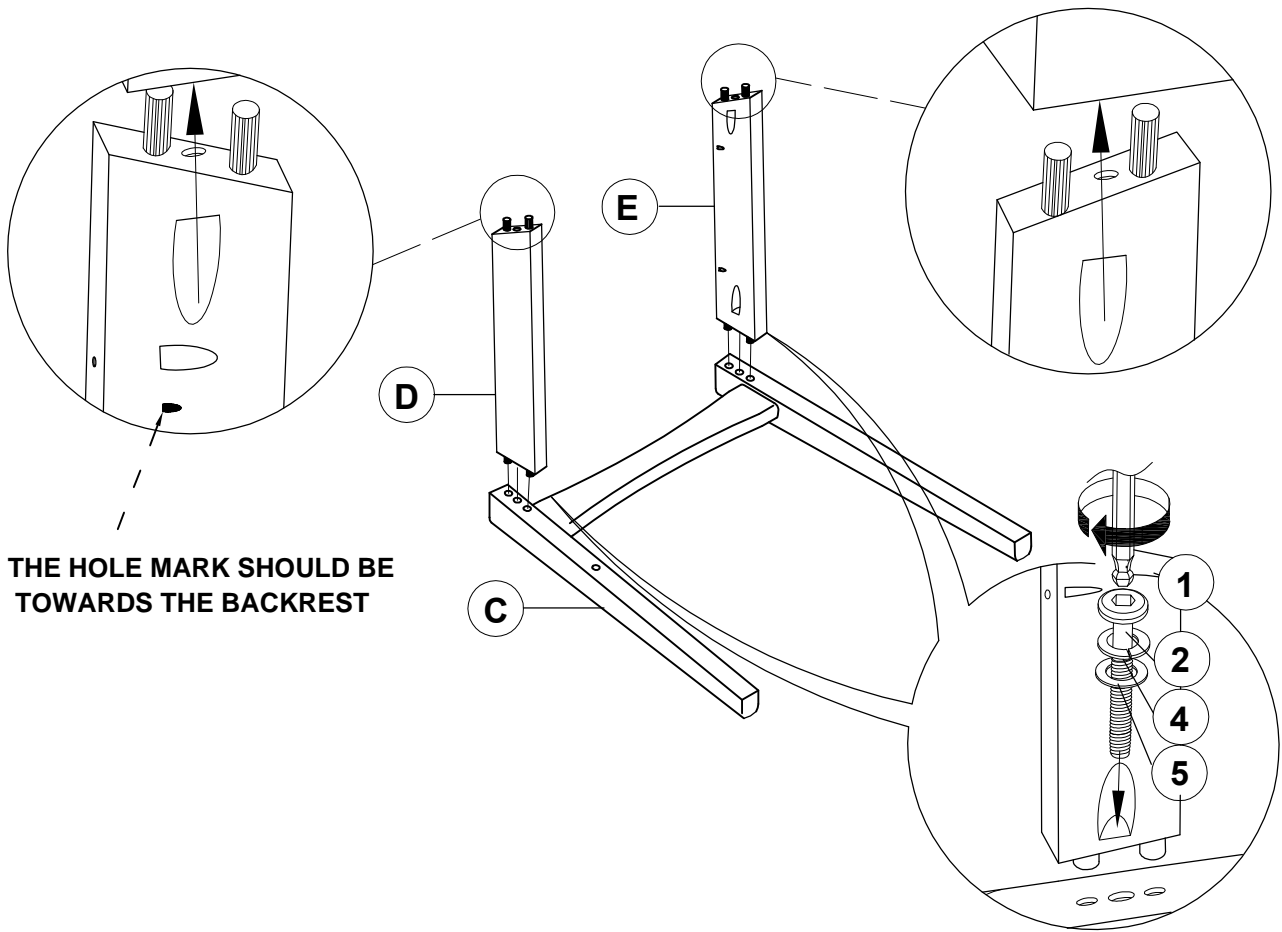

STEP 2

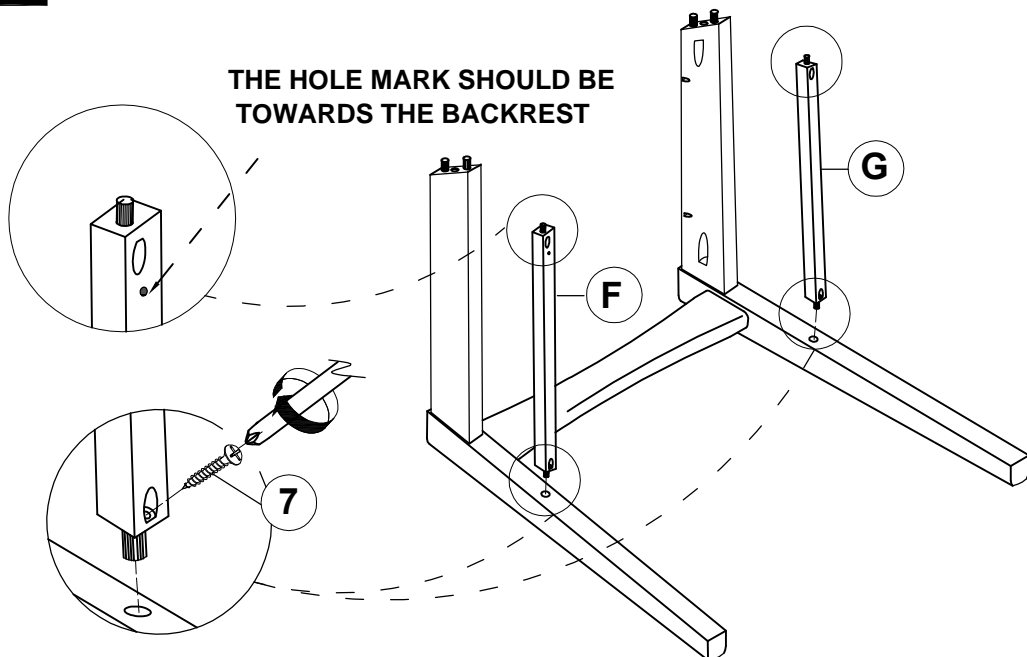

ASSEMBLY INSTRUCTIONS

STEP 3

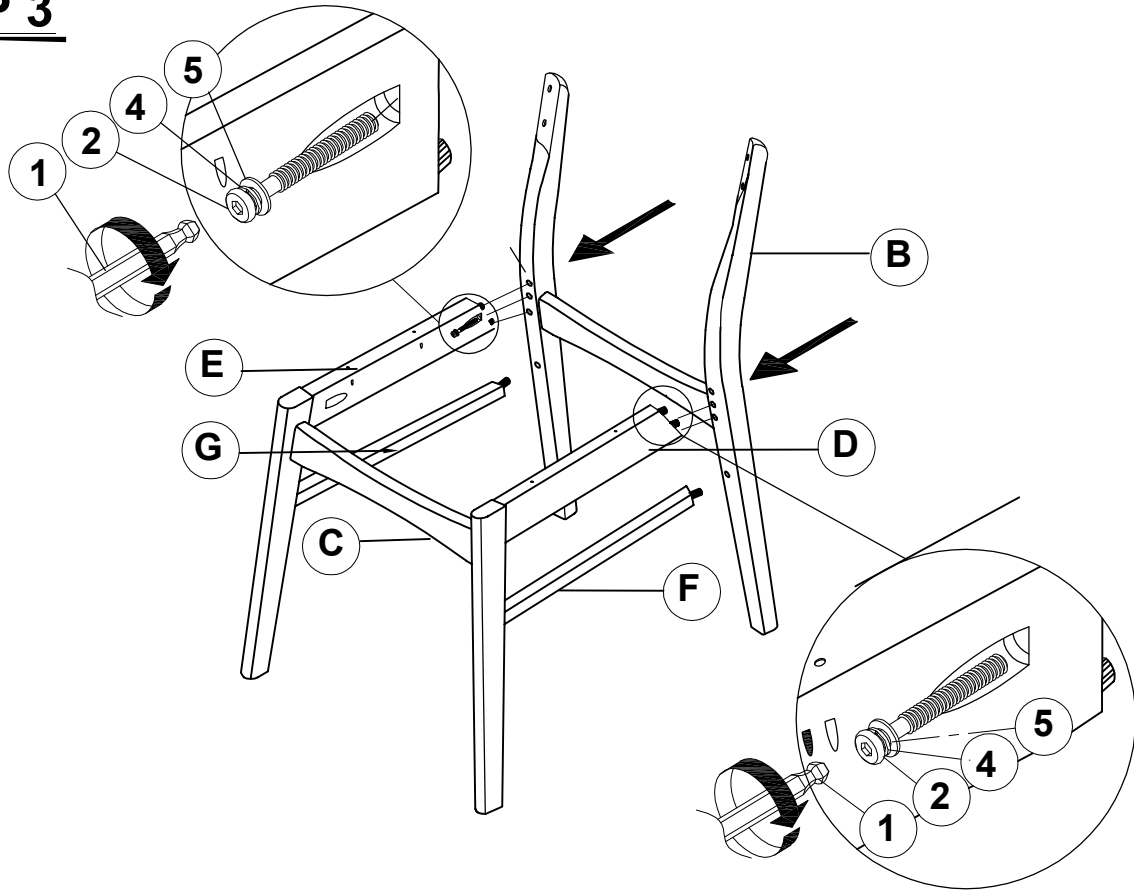

STEP 4

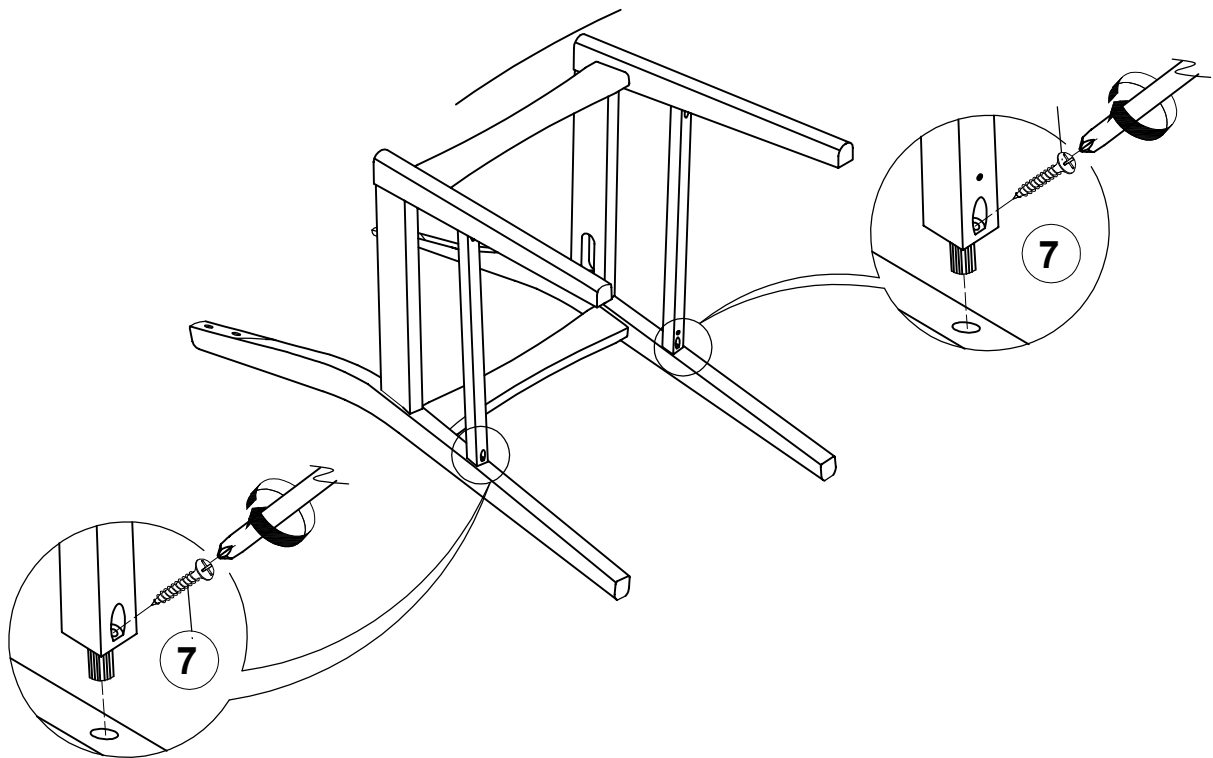

ASSEMBLY INSTRUCTIONS

STEP 5

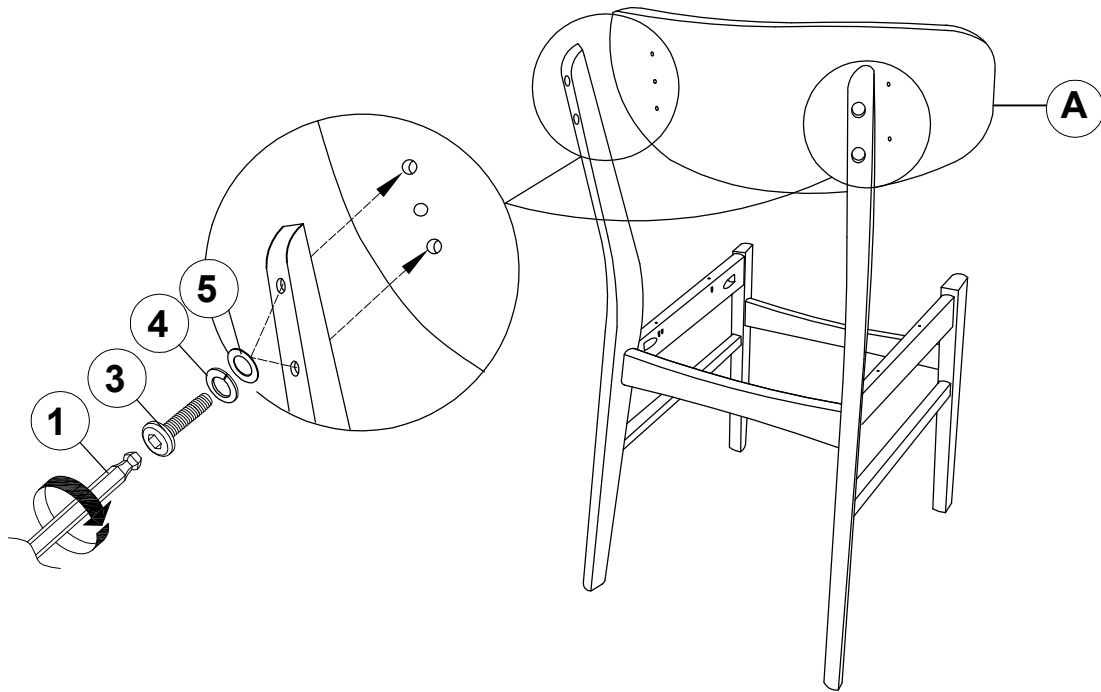

STEP 6

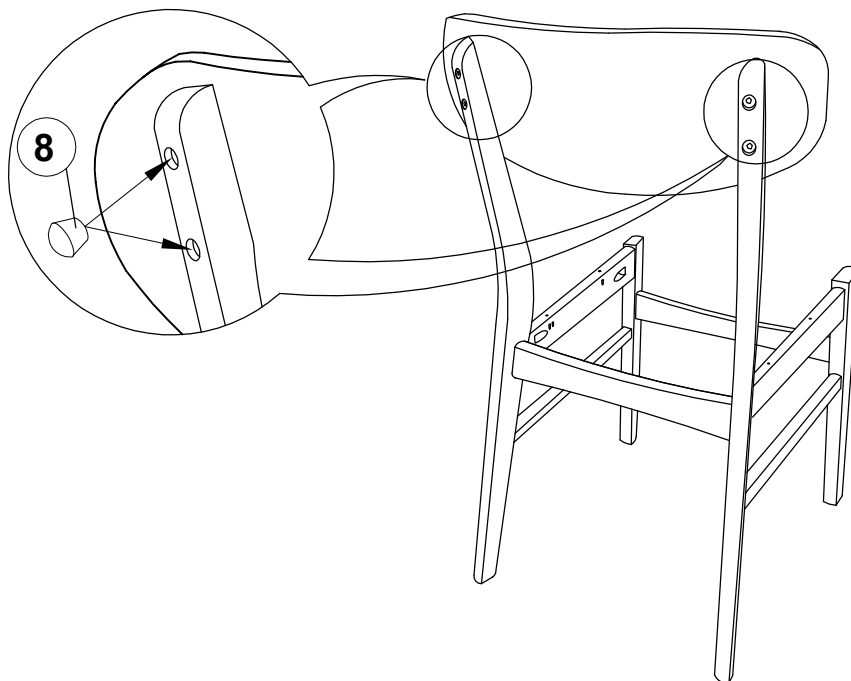

ASSEMBLY INSTRUCTIONS

STEP 7

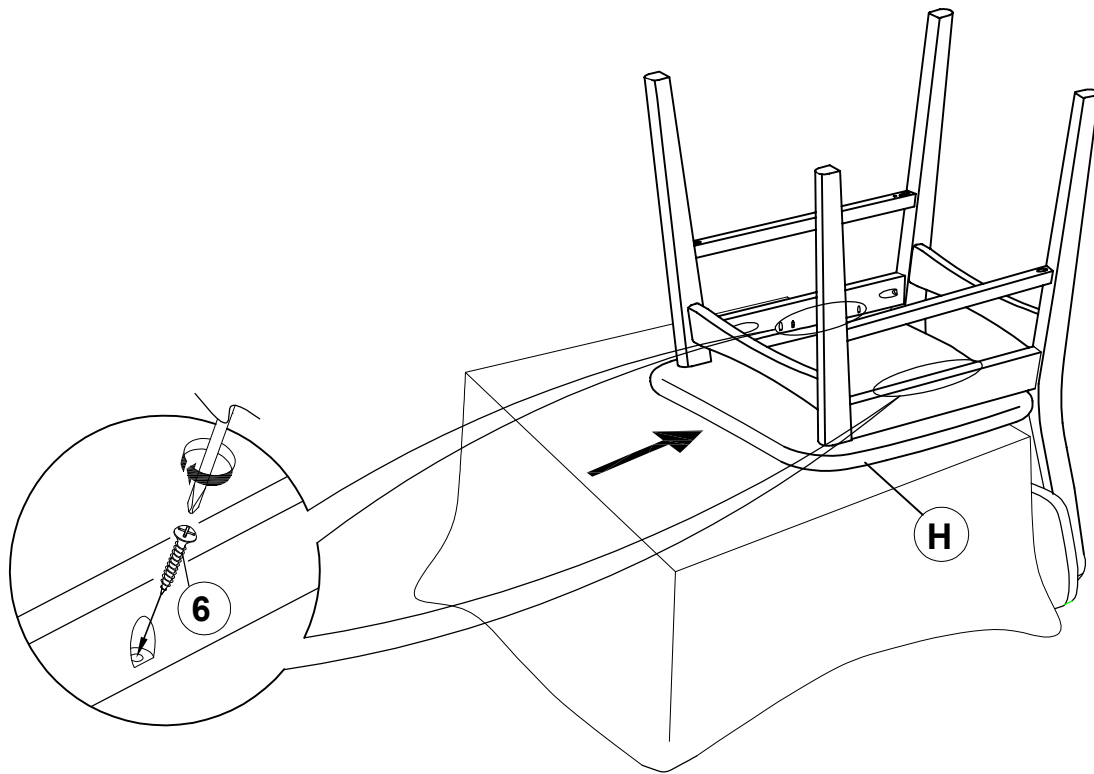

STEP 8 COMPLETE

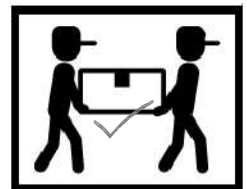
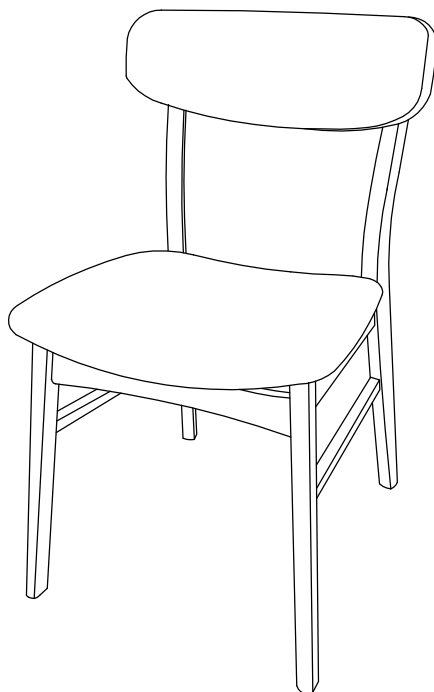

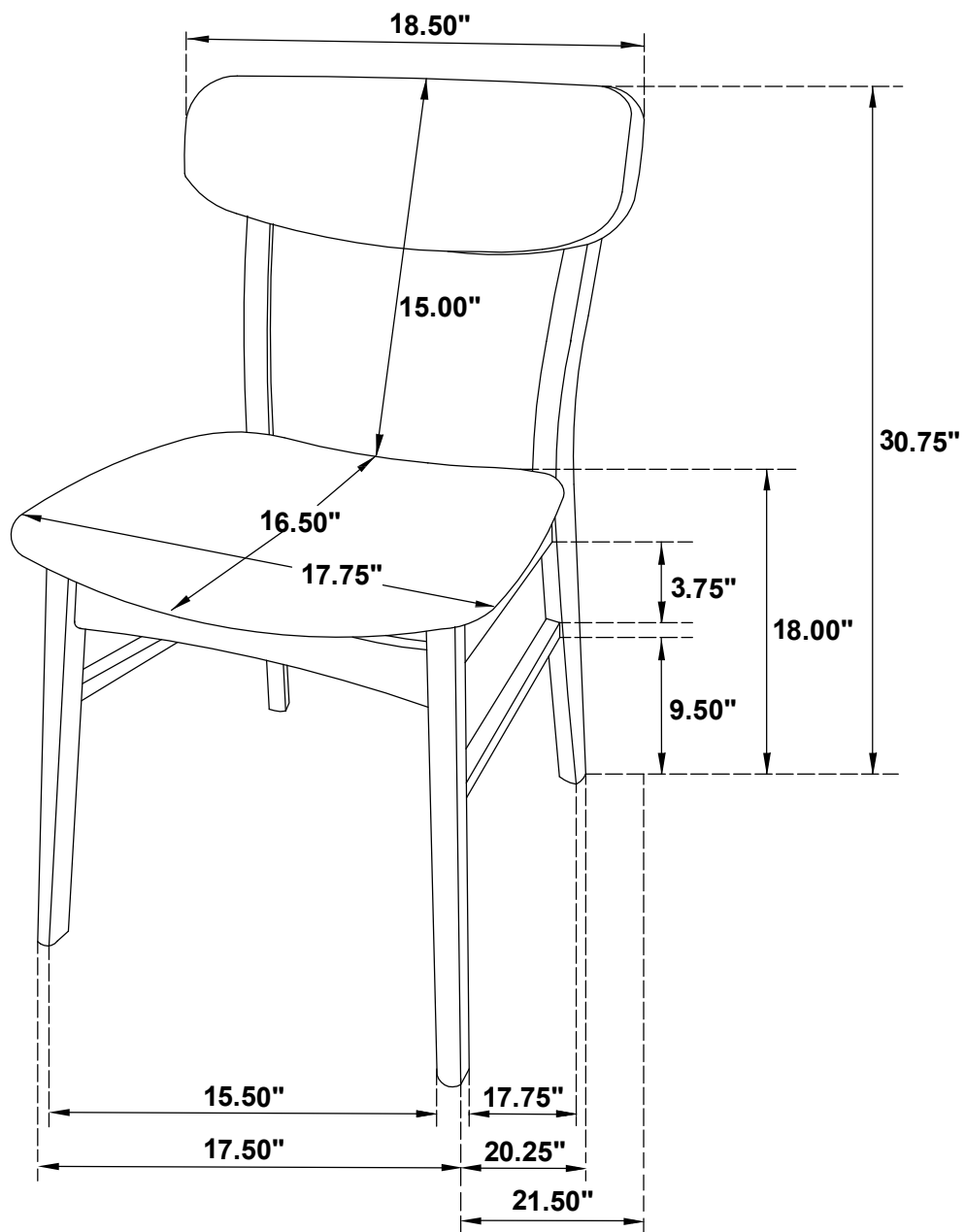

Note: Dimension tolerance $\pm 5\%$