

OWNER'S MANUAL

# MANUAL RETRACTABLE AWNING

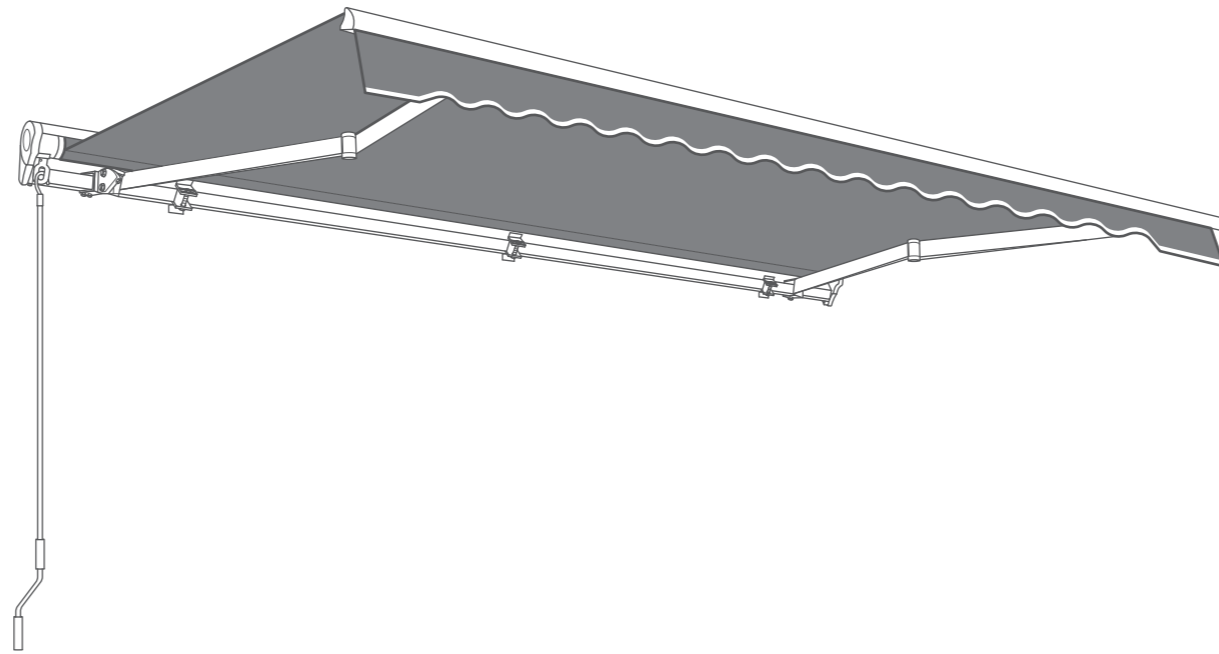

Hello,  
Let's get started

**○ PURCHASER'S AGREEMENT**

By accepting delivery of this product, you promise that you will not change, alter, or modify this product or remove or render inoperable or unsafe any guards, shields or other safety features of this product.

You will not refuse or neglect any retrofit kits that may provide to enhance and preserve the safe use of this product.

# CONTENTS

<b>I</b>	<b>SAFETY GUIDELINES</b>	- 01
<b>II</b>	<b>MAINTENANCE</b>	- 01
<b>III</b>	<b>ASSEMBLY INSTRUCTIONS</b>	- 02
	<ul style="list-style-type: none"><li>• Preparation</li><li>• Part List</li><li>• Parts Exploded View</li><li>• Assembly Steps</li></ul>	
<b>IV</b>	<b>WARRANTY</b>	- 18
<b>V</b>	<b>CUSTOMER SUPPORT</b>	- 19
<b>VI</b>	<b>REPLACEMENT POLICY</b>	- 20

# I. SAFETY GUIDELINES

## ⚠️ WARNING

For your own safety, please strictly follow the instructions in this manual, otherwise personal injury may result!

### Before you proceed, please read the following safety precautions:

- Due to the strong elasticity of the umbrella arms, please tie the umbrella arms together when assembling the umbrella arms. Do not stand facing the front of the awning when cutting the strap between the arms. Hold on tight and slowly stretch until fully open.
- The product is bulky and heavy, requiring two adults to carry and install it. Please use all screws and nuts correctly during installation, it is very dangerous if loosened.
- Do not place, hang or stand objects or people on the awning. Doing so may damage the awning or cause serious personal injury, even death in extreme cases.
- Do not install it in a high place, a windy place, a place with vibration or impulse, and a high-temperature place such as a wall near the furnace. Never use it for any purpose other than that suggested. Be careful with your fingers when installing.
- Do not open the awning under the following circumstances:

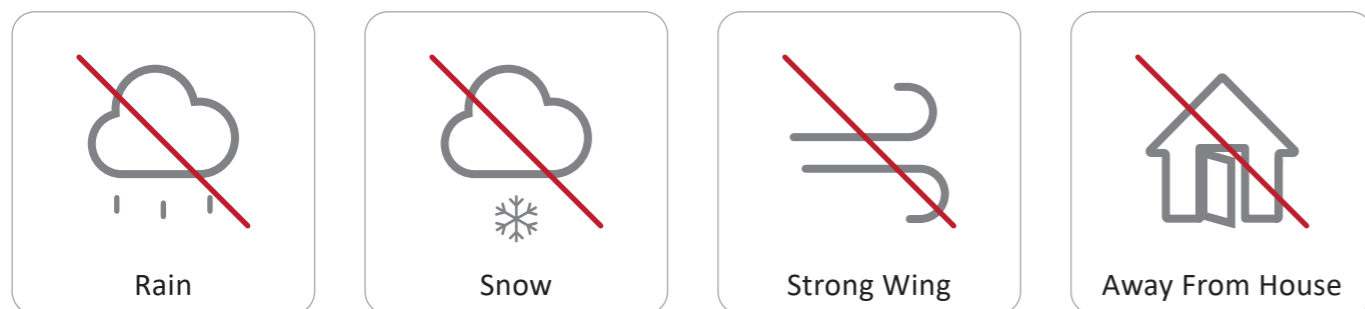

# II. MAINTENANCE

- Do not use bleach, acid, or other solvents on the fabric or frame parts.
- Please inspect and tighten all bolts or fasteners on a regular basis to ensure proper performance and safety of your side awning screen.

# III. ASSEMBLY INSTRUCTIONS

## 1. Preparation

- Before you start, check the condition and quantity of all parts according to the parts list.

## ⚠️ WARNING

Do not remove the safety wrapping that holds the awning arms in place. Premature removal of the protective tape may cause the curved arm to pop open and cause serious injury.

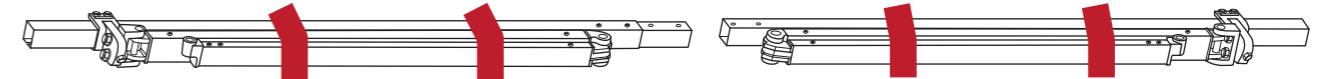

- Please prepare all the necessary tools.

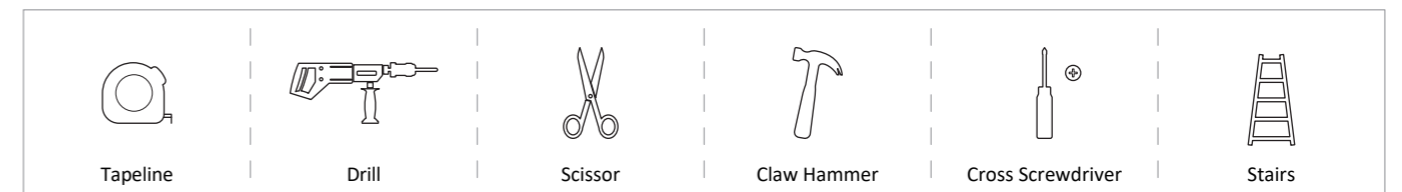





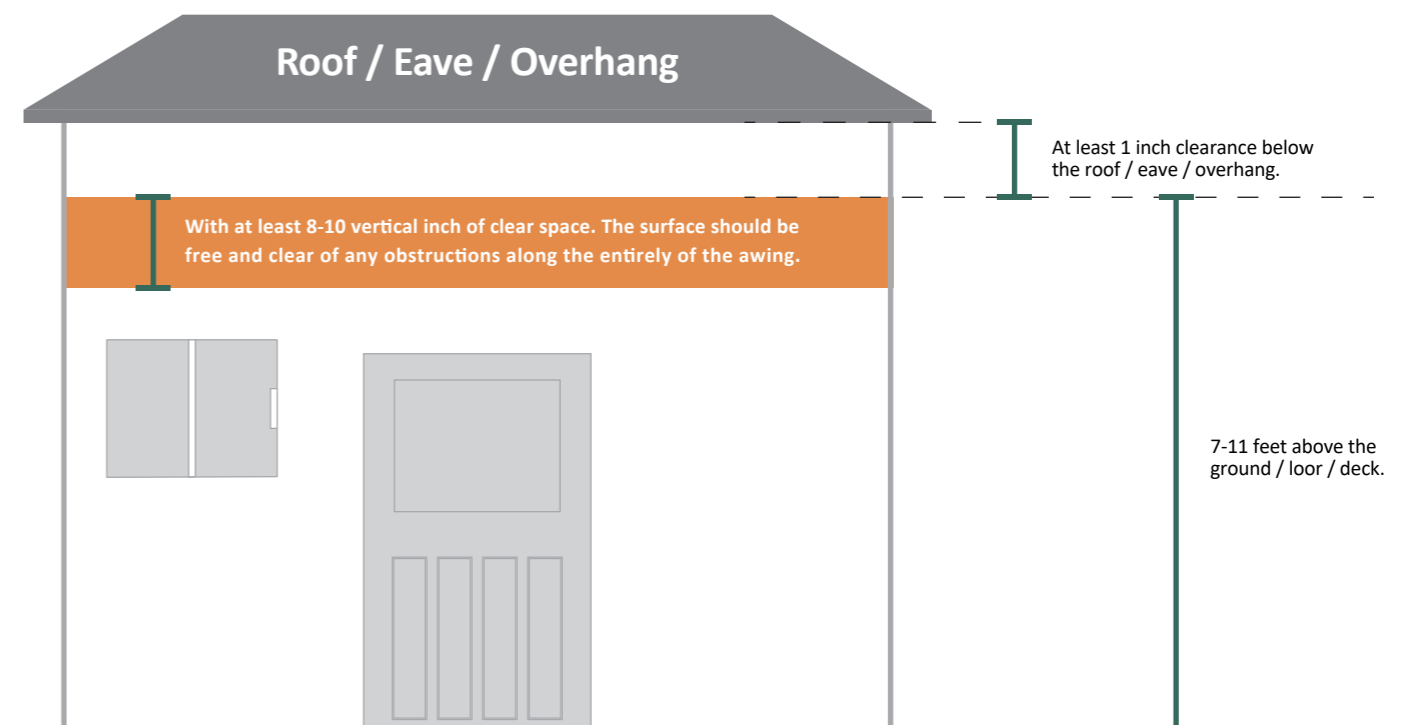



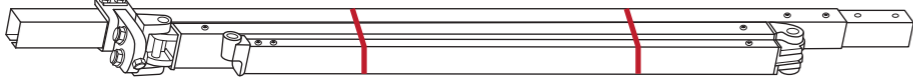
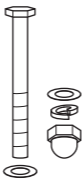
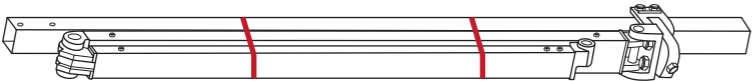

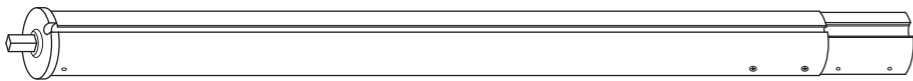

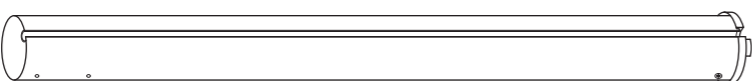
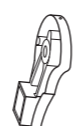
### Determine where to install your Awning?

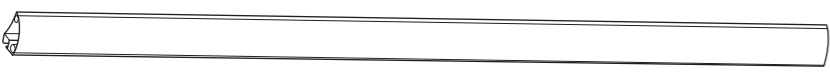
- Reference Location:

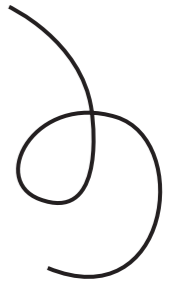
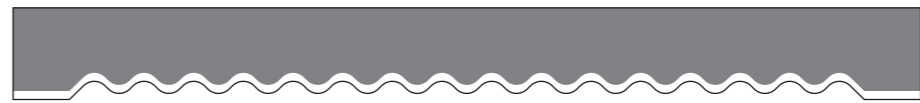
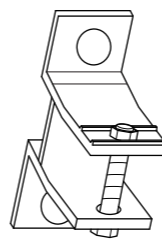

## 2. Part List

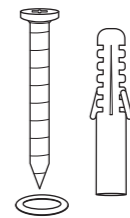
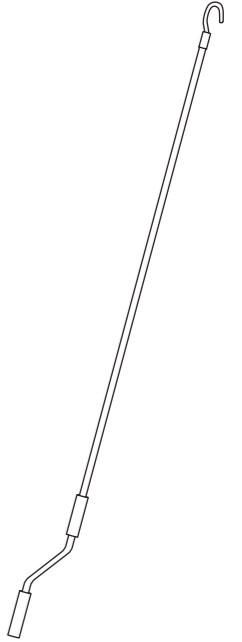
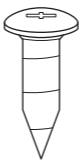
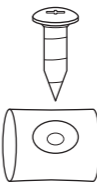
Frame Part	
<b>A-1</b>  Torsion Bar with Arm ( Left ) x1	<b>D</b>  Torsion Bar Screw x2 +1
<b>A-2</b>  Torsion Bar with Arm ( Right ) x1	<b>S</b>  Roller Middle Bracket Shelf x1
Roller	
<b>B-1</b>  Roller (Left) x1	<b>E-1</b>  Left Roller Support x1
<b>B-2</b>  Roller ( Right ) x1	<b>E-2</b>  Right Roller Support x1
Front Bar	
<b>C-1</b>  Front Bar ( Left ) x1	<b>F</b>  Arm Link x2
<b>C-2</b>  Front Bar ( Right ) x1	<b>G</b>  Plastic Cover of Front Bar x2

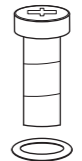
Fabric			
<b>M</b>  Fabric x1	<b>N</b>  Fabric Guiding Wire x3		
<b>O</b>  Valance x1			
Other Accessories			
<b>H</b>  Wall Bracket Set x3	<b>I-1</b>  Expansion Bolts x6 +1	<b>I-2</b>  Wood Screw x6 +1	<b>L</b>  Hand Crank x1
<b>J</b>  Roller & Front Bar Screw x8 +1	<b>K-1</b>  Big Fabric Plug x2 +1	<b>K-2</b>  Small Fabric Plug x2 +1	
<b>R</b>  Half Cassette x2	<b>T</b>  Half Cassette Screw x4 +1		

### 3. Parts Exploded View

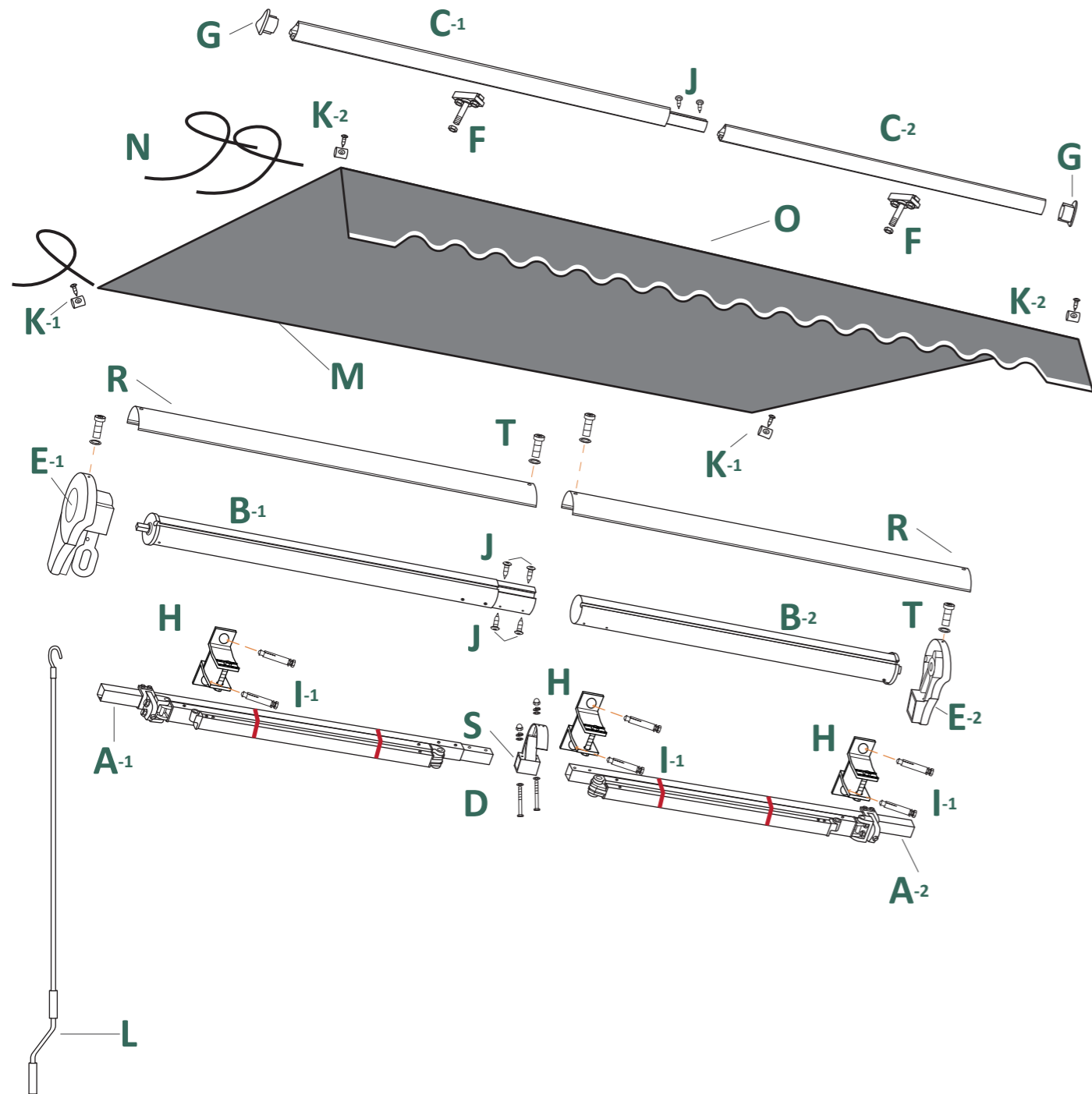

### 4. Assembly Steps

#### Step1

Fix left & right Torsion Bar with Arm (#A-1, #A-2) and Roller Middle Bracket Shelf (#S) by Screws (#D).

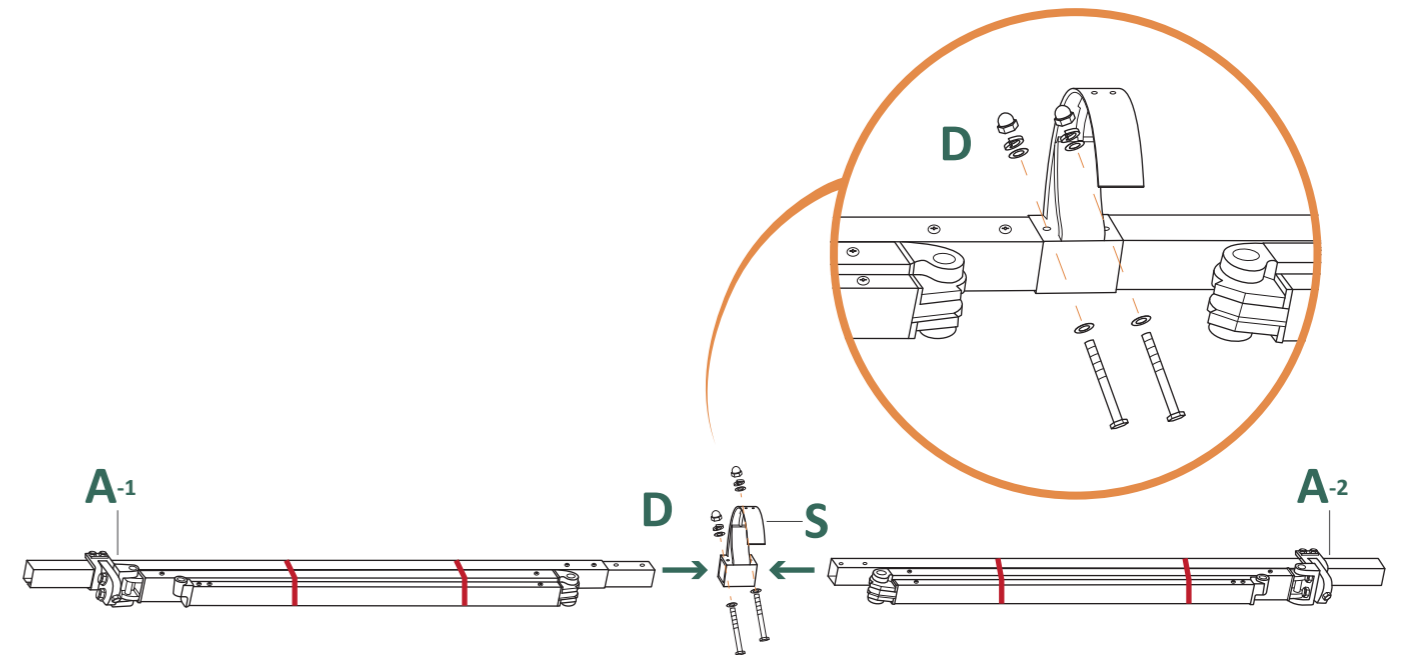

#### Step2

Connect left with right Roller (#B-1, #B-2) by Screws (#J).

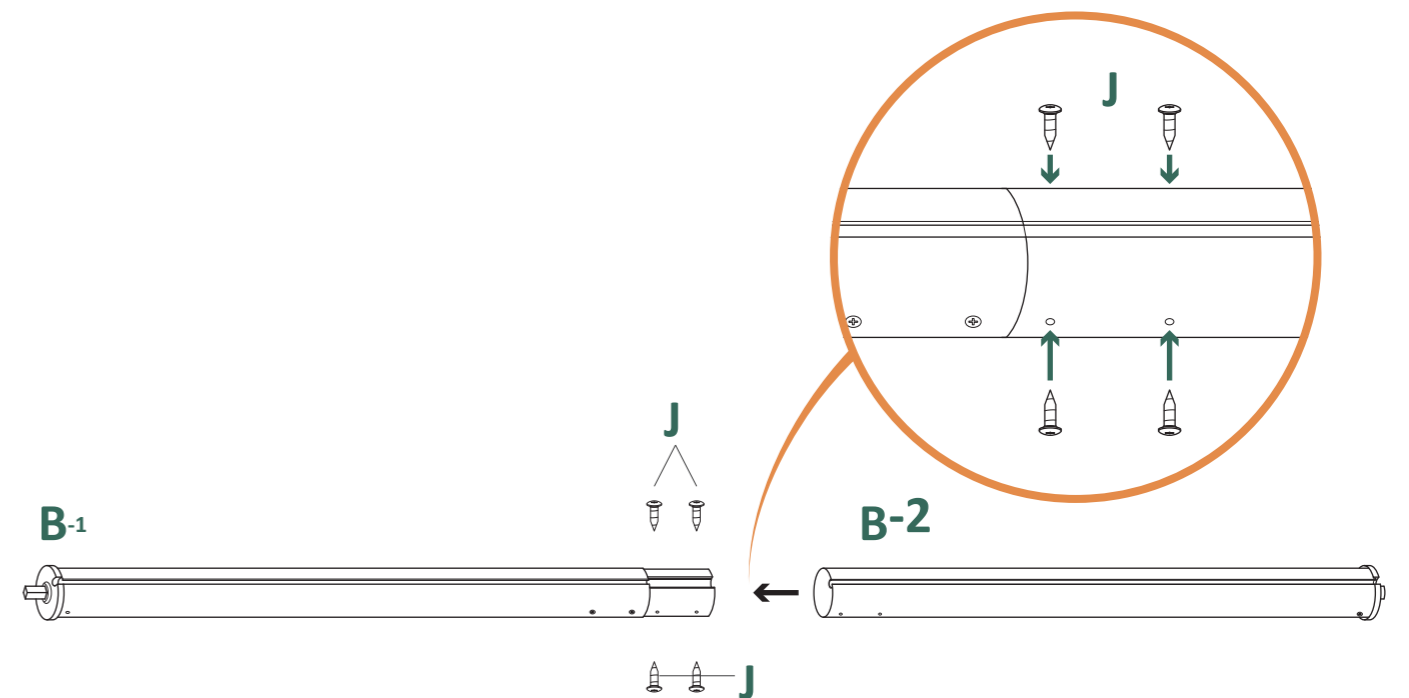

### Step3

Connect left with right Front Bar ( #C-1, #C-2 ) by Screws ( #J ).

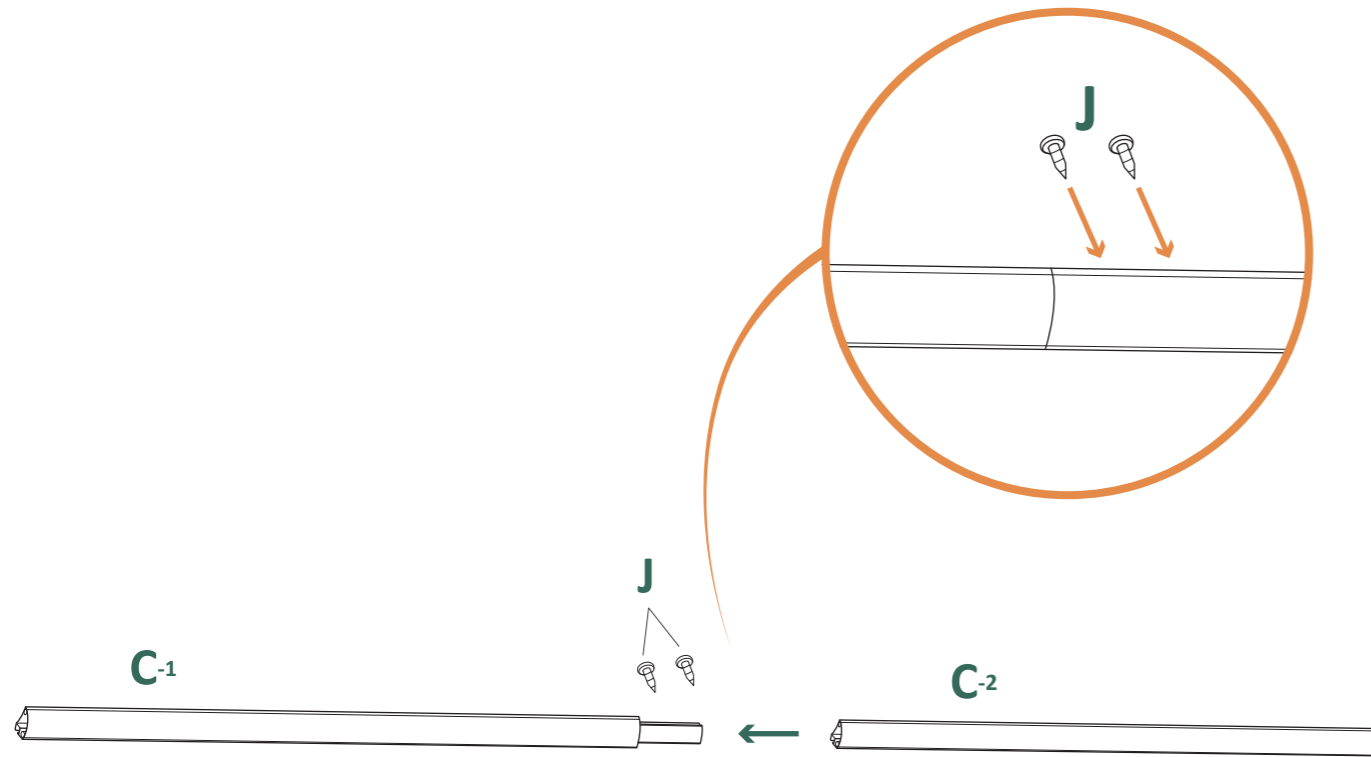

### Step4

Thread three Guiding Wires ( #N ) through both ends of the large Fabric ( #M ) and side of Valance ( #O ).

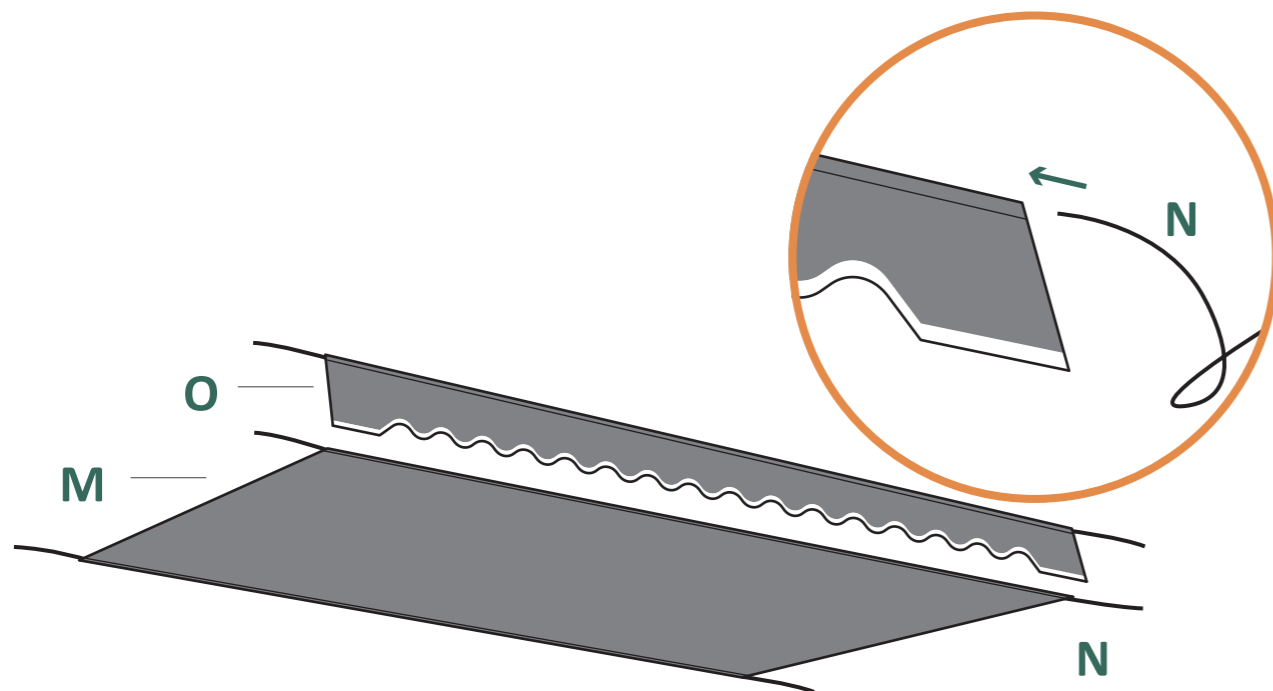

### Step5 - Install the Fabric

- (1). Pass two sides of Fabric ( #M ) which wearing Guiding Wires ( #N ) through the slot of long round Roller and Front Bar.  
Cutting off excess threads.

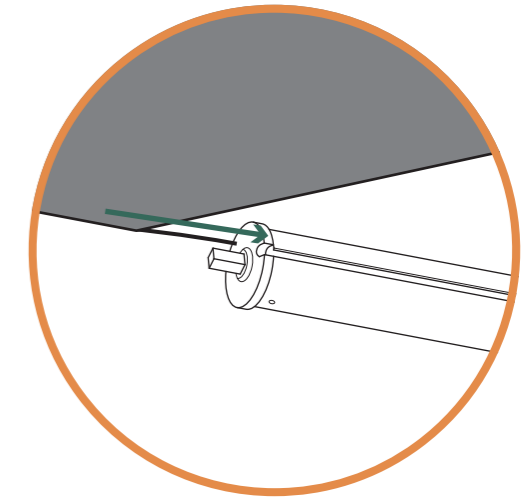

- (2). Insert Big and Small Fabric Plug ( #K-1, #K-2 ) respectively into two ends of Roller and Front Bar.  
Then Rotate Roller counterclockwise so that Fabric ( #M ) is evenly wound around Roller.

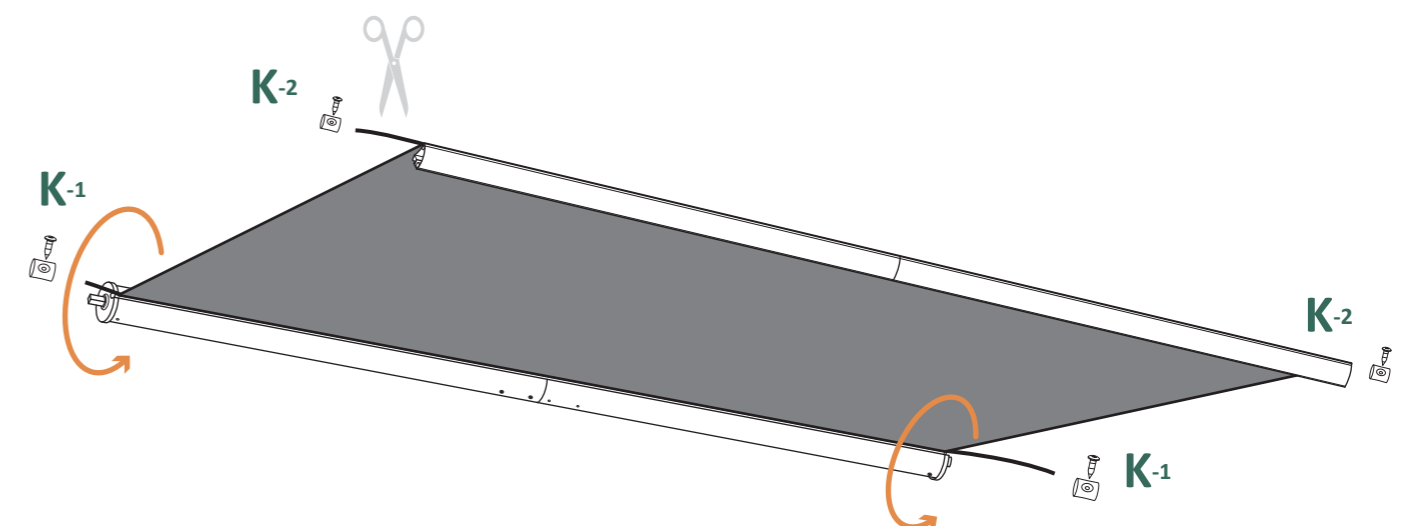
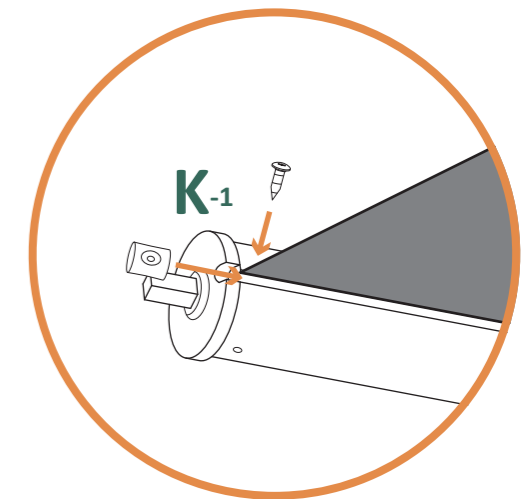

## Step6

Sleeve rolled Roller from **step 5** with Torsion Bar from **step 1**.

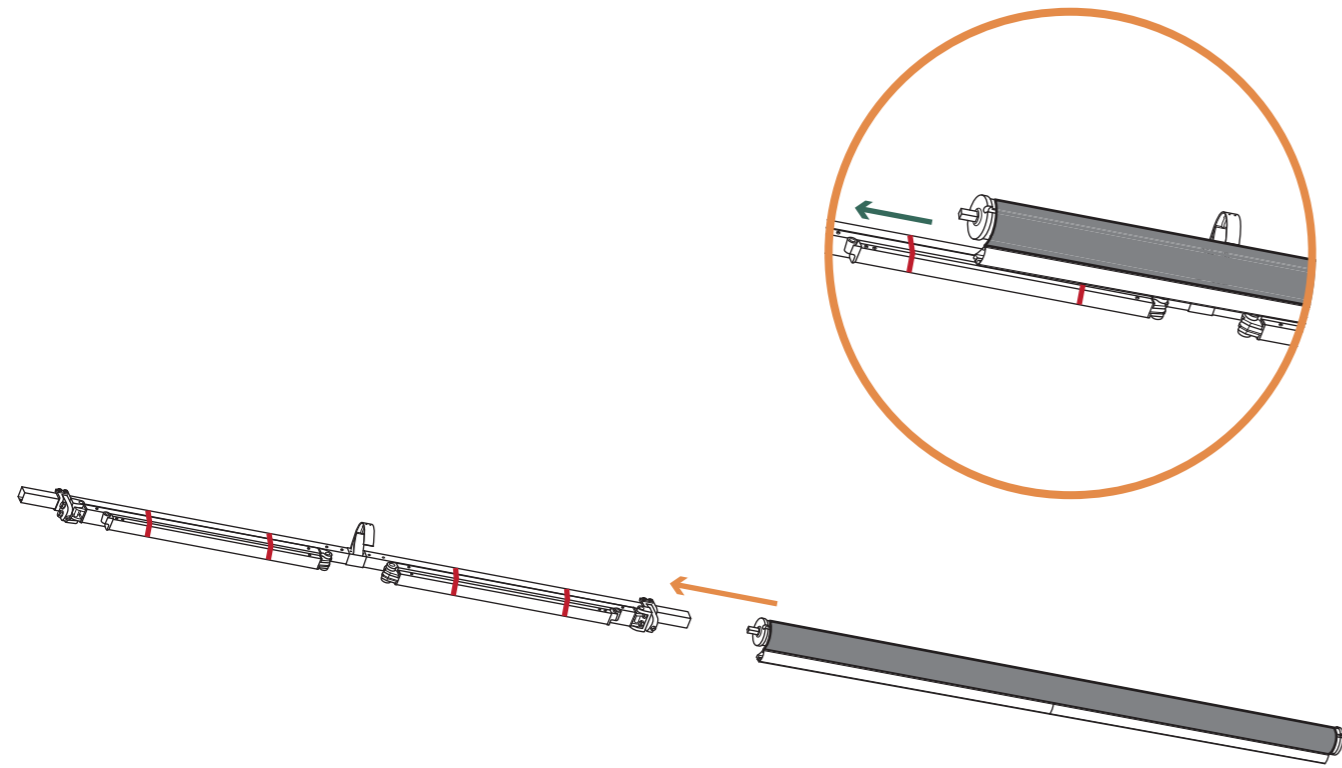

## Step7

Insert Half Cassette (**#R**) and fix it with (**#S**) by Screws (**#T**).

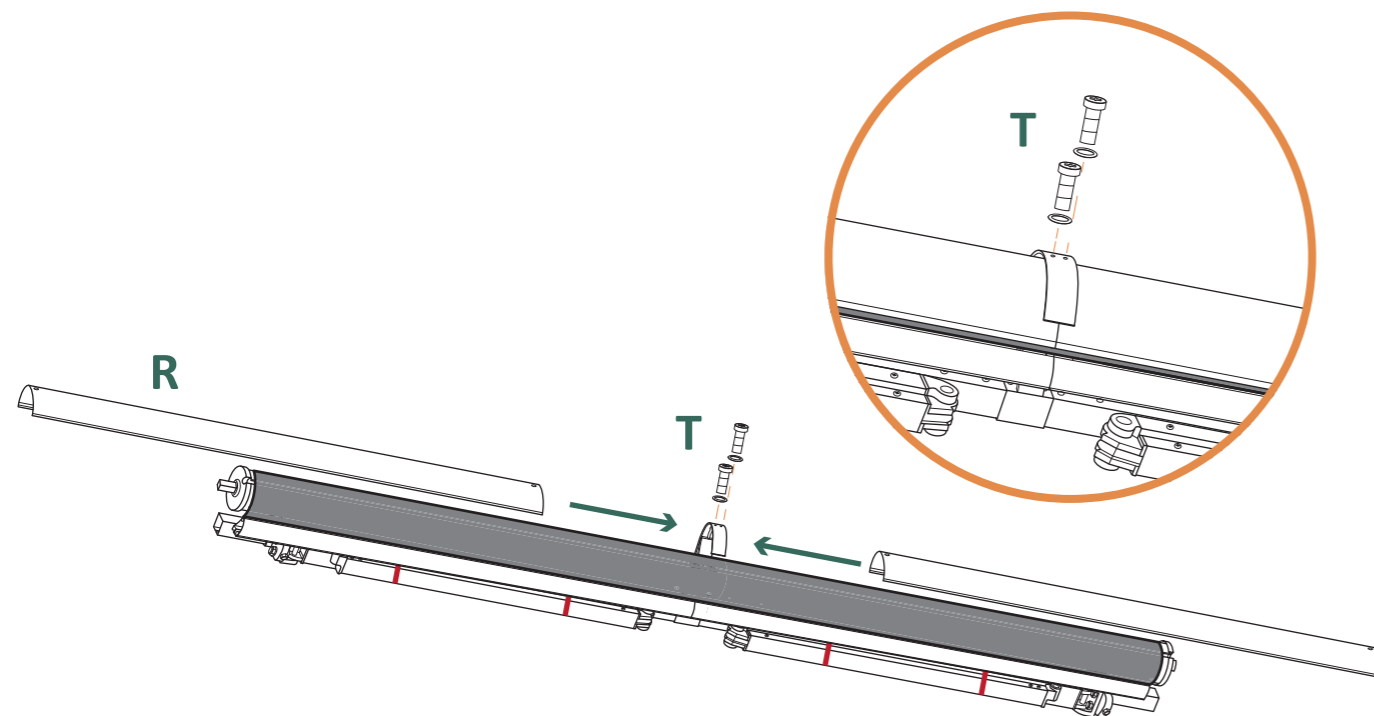

## Step8 - Connect Roller with Torsion Bar

(1). Sleeve Left & Right Roller Support (**#E-1, #E-2**) with two ends of Roller and Torsion Bar.

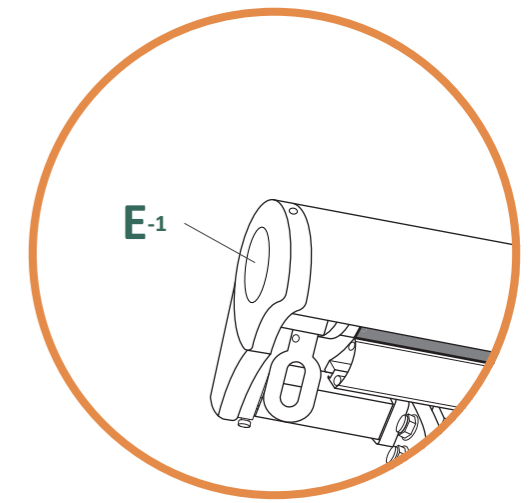

(2). Fix (**#E-1, #E-2**) and (**#R**) with Screws (**#T**).

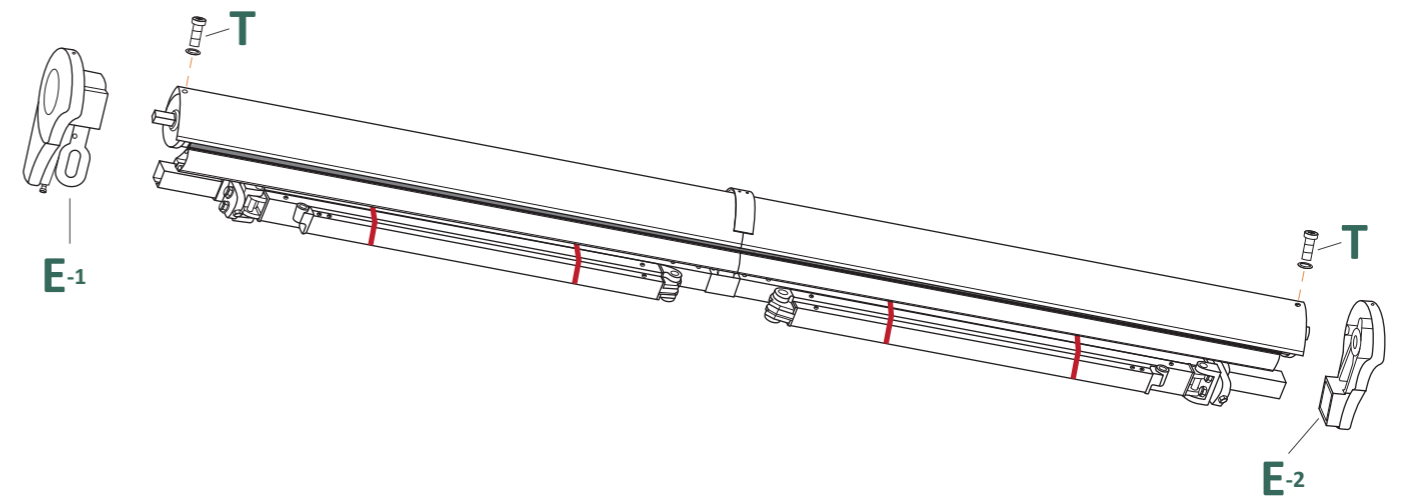
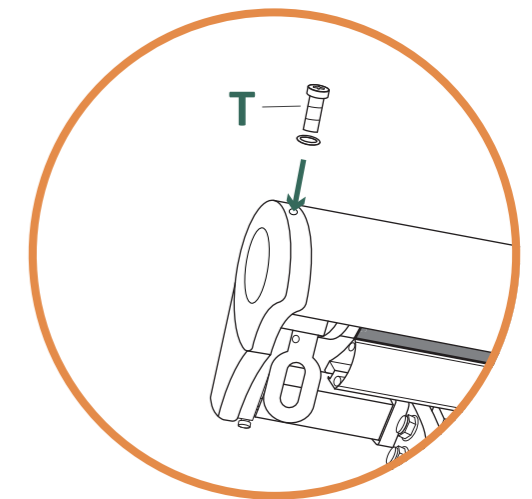

## Step9

Slide the Arm Link ( #F ) into each end of Front Bar, then insert ( #F ) into holes in Torsion Bar.

- Note:** (1). If it is not good to slide in, you can loosen the two short screws a little.  
(2). Please tighten screws at the bottom of ( #F ).

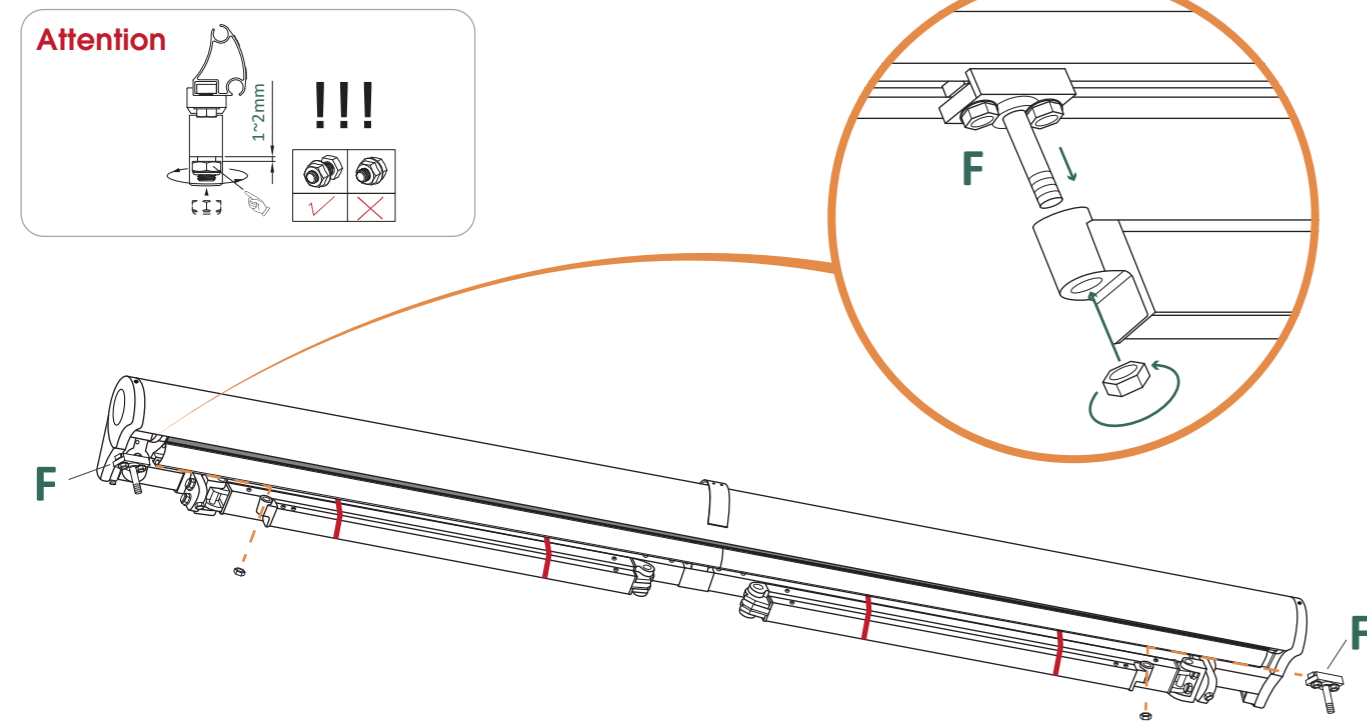

## Step10

Thread ( #O ) with ( #N ) through the other slot of Front Bar.

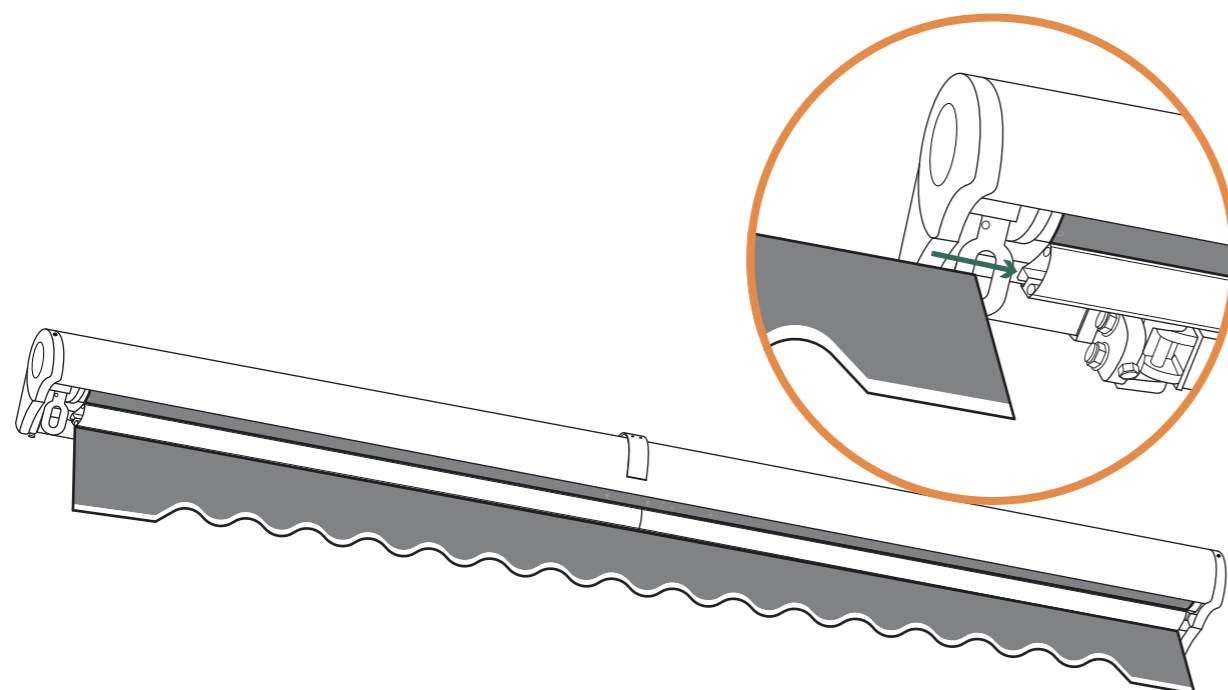

## Step11

Put Plastic Cover ( #G ) on ends of Front Bar.

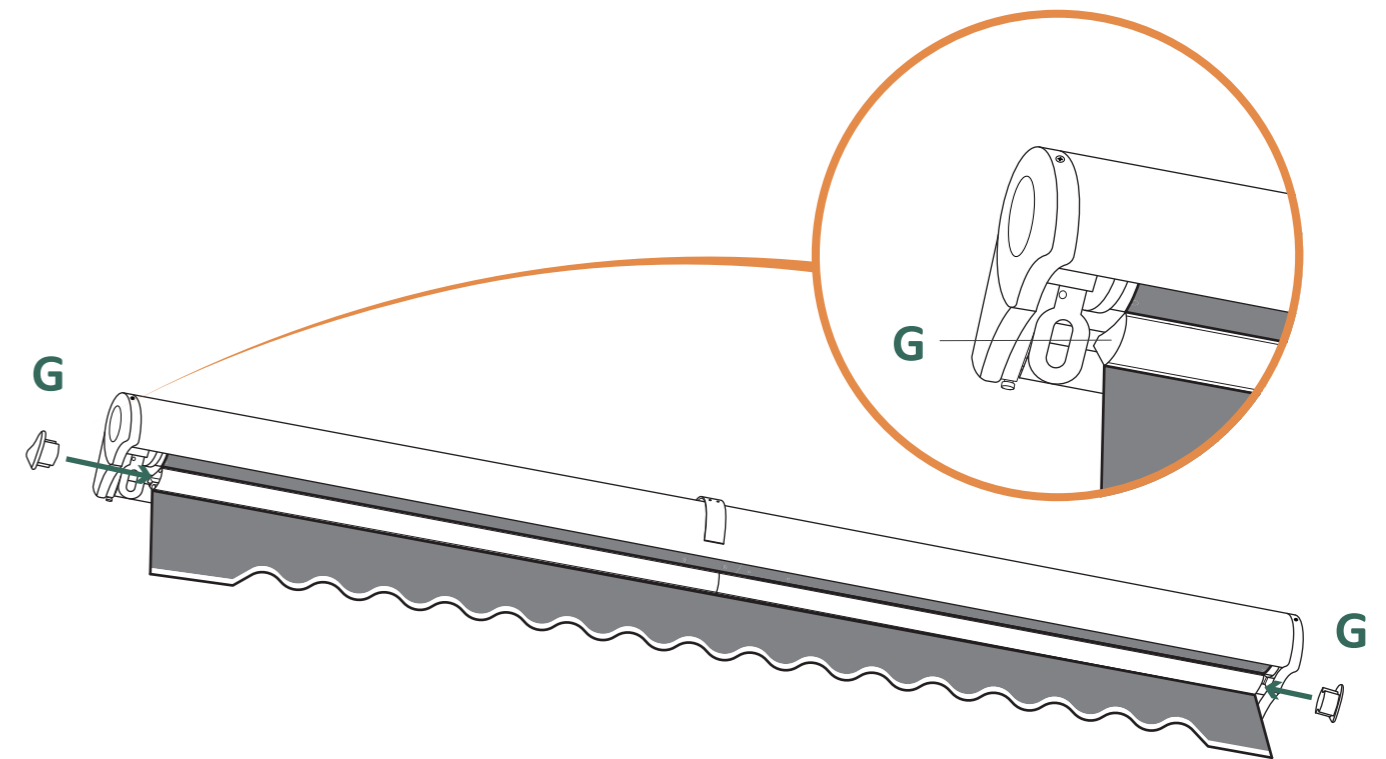

## Step12

Measure the total length of the canopy "Length".  
Divide the total length roughly into four segments ( find three points ).

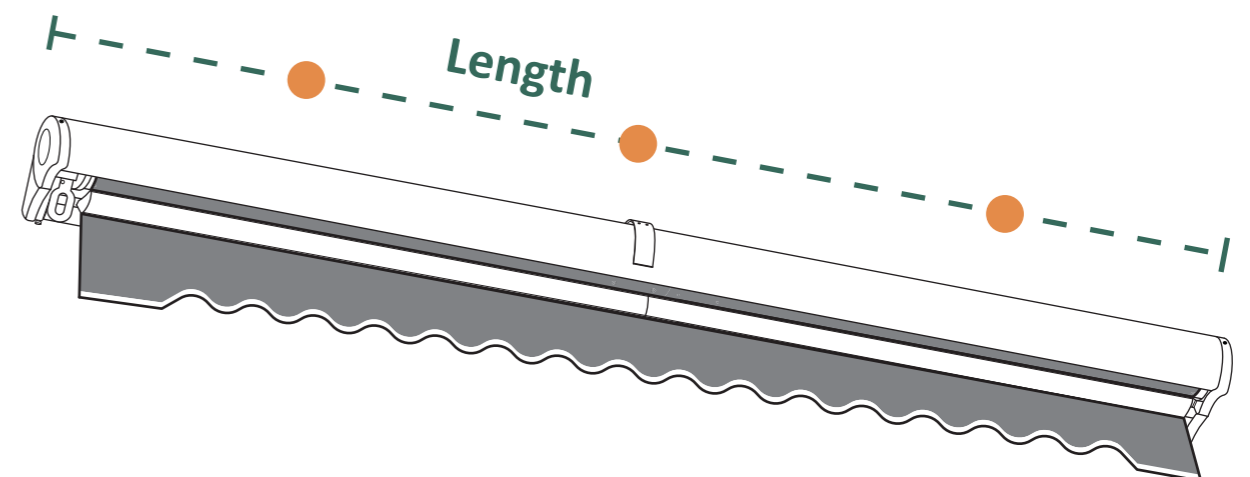

### Step13 - Mounting on the Wall:

- (1). Drill holes in the wall with a 0.55 inches diameter drill bit, please pay attention to the deep of hole that should not be less than 4 inches.

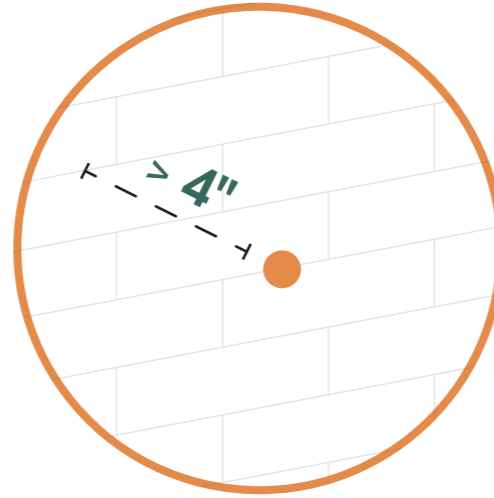

- (2). Secure the Wall Bracket ( #H ) with Expansion Bolts ( #I-1 ) / Wood Screw ( #I-2 ).

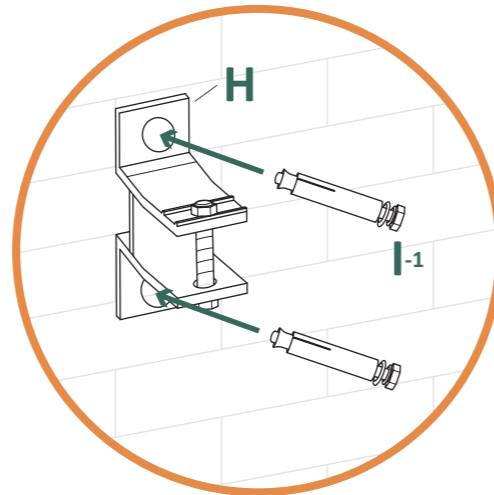

- (3). Sleeve assembled awning on the Wall Bracket ( #H ), lock the screws and tighten the nuts.

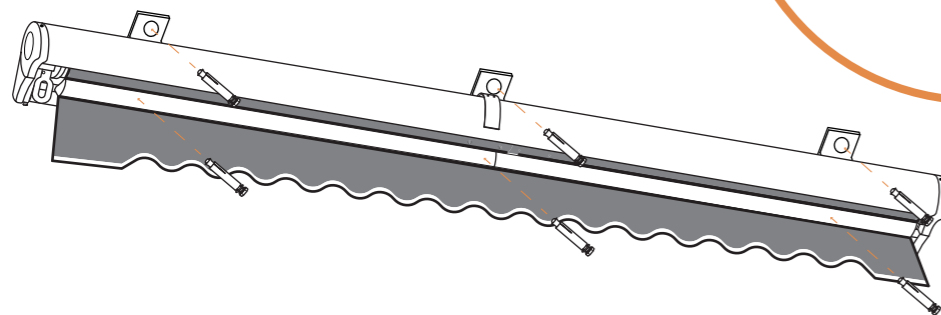
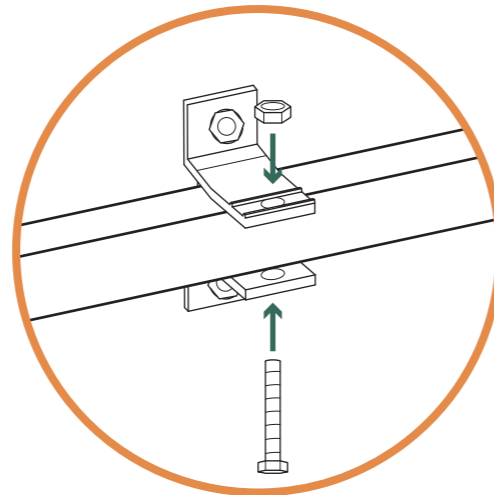

### Step14 - Hang the Hand Crank

- (1). Cutting the safety packaging of the curved Arm.

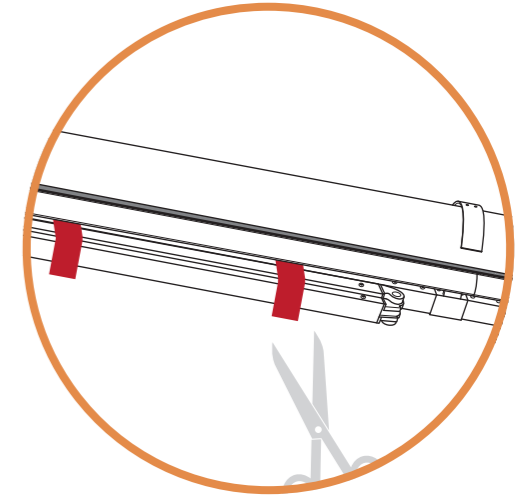

- (2). Hang the Hand Crank ( #L ) on the awning hook.

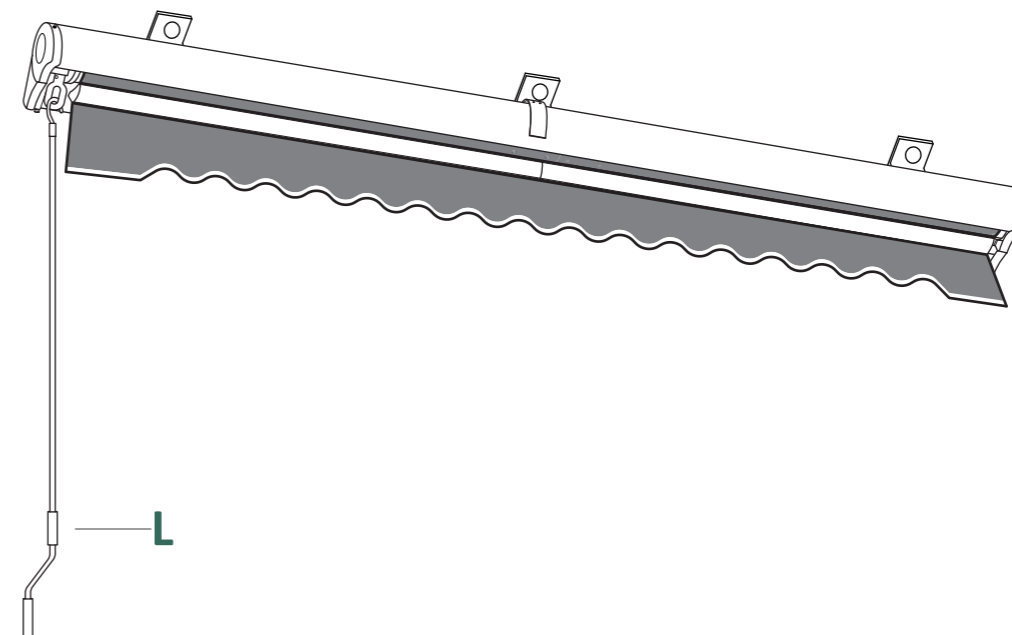
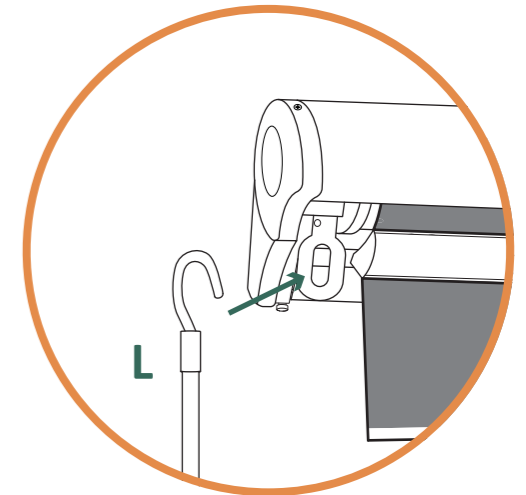

## Step15 - Check and Use Awning

### (1). How to balance your awning

If your awning appears to be one high and one low after installation, you can follow these steps to adjust it:

- ① First, please check all joints to ensure there are no loose or misaligned parts.
- ② Please check if the crank arm appears to be uneven in height, if so please select one of the jack bolts in each arm seat to loosen and manually adjust the height to match the other side. After adjustment, tighten the bolts to fix the crank arm.

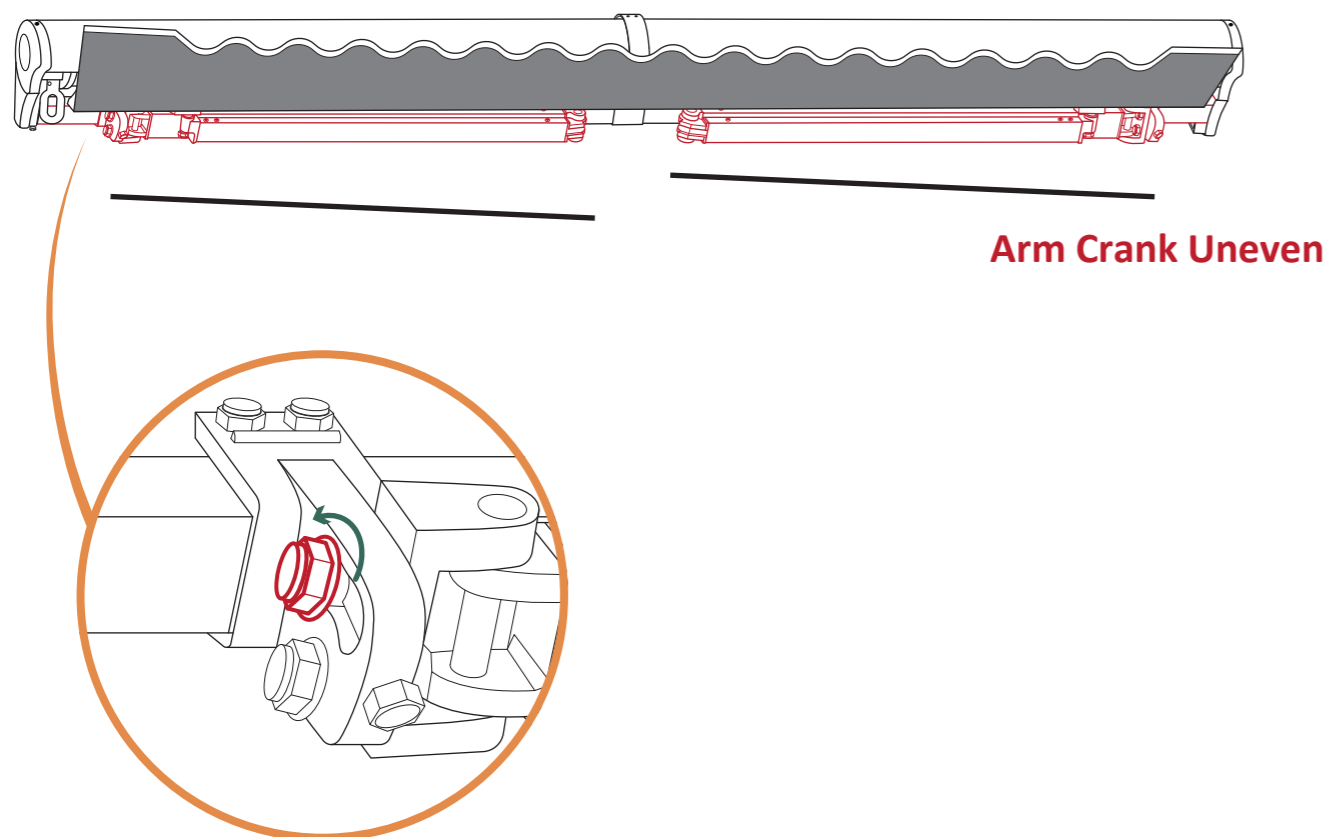

### (2). How to adjust the angle of the awning

Usually the tilt angle of the adjustable awning is preset to 30 degrees, if you want the awning fabric to tilt more to provide better shade you can screw the locking nut in to raise the fabric; Conversely, if you want the fabric to tilt less you can screw the locking nut out to lower the fabric.

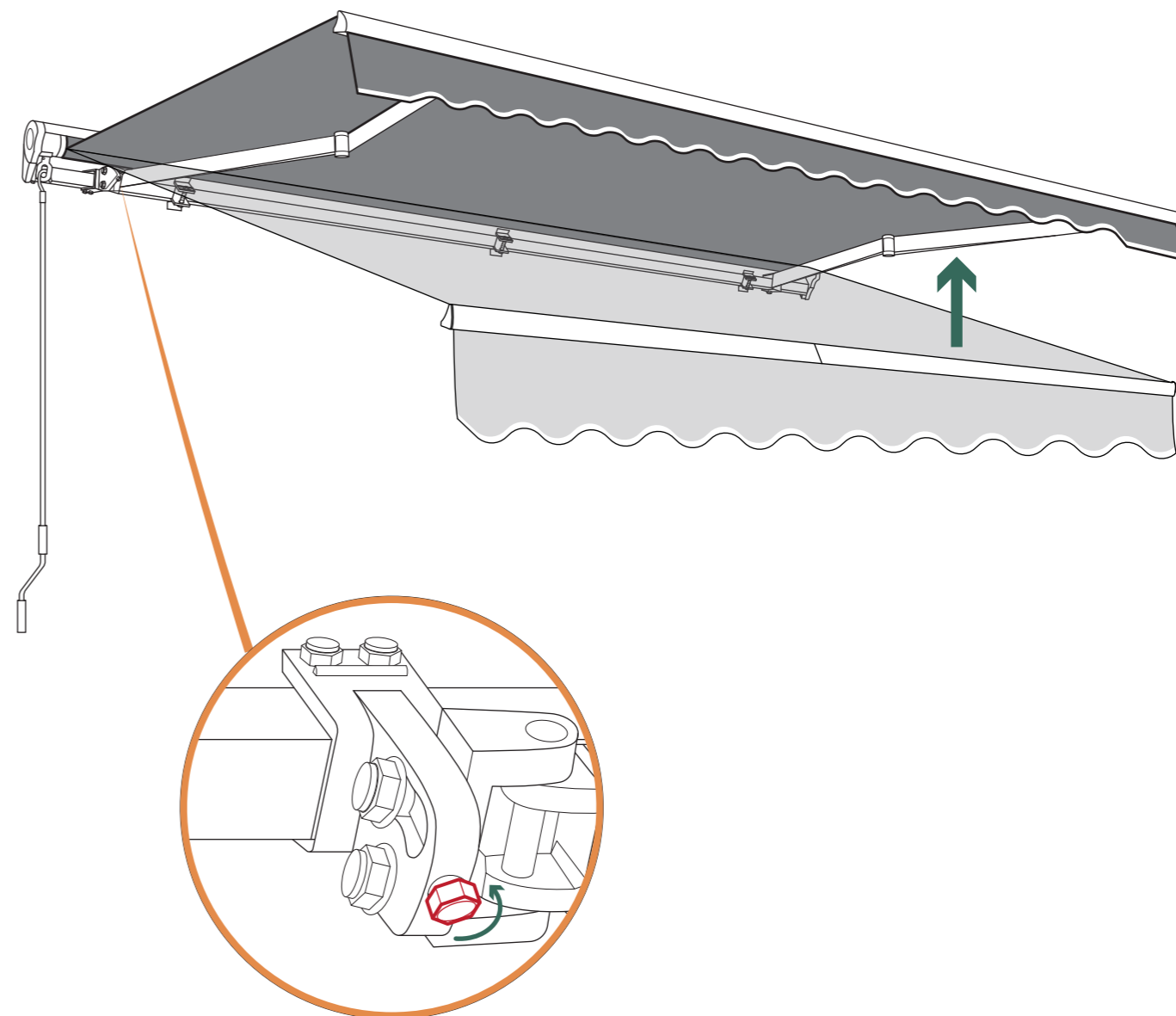

#### ATTENTION

After the adjustments have been made, test the opening and closing functions of the awning to ensure that the fabric unfolds and closes smoothly without snags or twists.

(3). Use of awning

Awning can be retracted by rotating the hand crank handle.

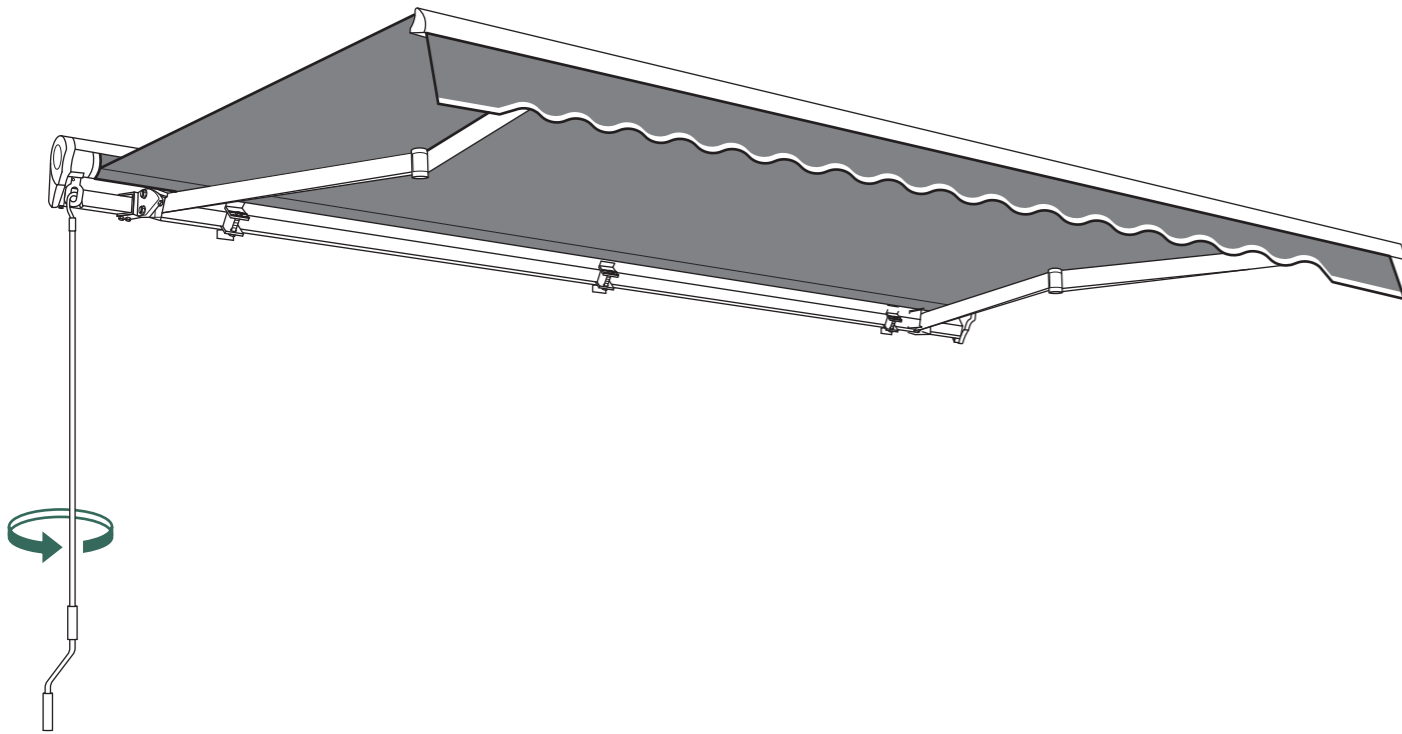

## IV. WARRANTY

■ **Notice**

- For product beyond the limited manufacturer warranty period and scope, We can also provide replacement service, but a basic charge will be charged according to the circumstances.
- The warranty only applies to our products and does not include any accessories or enhancements.
- Warranties are only valid in the 48 contiguous United States and are contingent upon the consumer operating the product according to the corresponding instruction manual.

<b>Awning Frame</b>	★ 1 Year
<b>Awning Fabric</b>	★ 6 Months

### CONSUMER WARRANTY LIMITATIONS AND EXCLUSIONS

All warranties begin on the date of delivery.

All warranties are to the original purchaser from us **ONLY**.

- We will replace the defective parts or send replacement product provided that the warranty parts have not been subjected to misuse, abuse or improper service by the consumer, for example, damaged wire arising in consequence of negligence or improper operation.
- Exclusions also include components with damage caused by:
  - Contamination
  - Abuse, misuse, accident, or negligence
  - Commercial use, or use other than normal
  - Improper operation, maintenance, or storage

**NOTE:**

We will pay standard shipping rates on all warranted parts for the first year. We can also sell you replacement part for a discount price when your product is out of warranty policy.

## V. CUSTOMER SUPPORT

If for any reason, we have fallen short of your expectations, or if you have any questions and suggests, please refer to the following contact information, we will do our best to work with you to make sure you are entirely satisfied.