

**Storage Cabinet**

## WARNING

Serious or fatal injury may occur from unexpected assembly or use.

1. During the assembly process, keep all parts away from babies or children.
2. Always securely fix this product to the wall. Make sure the wall area to be drilled is free from hidden electrical wires, water and gas pipes.
3. Use of tip-over restraints may only reduce, but not eliminate the risk of tip-over.
4. Unless specially designed to accommodate, do not set heavy objects on top of this product.
5. Place the heaviest items on the lowest shelf.
6. Never allow children to climb or bang on drawers, doors or shelves.

 <b>WARNING</b>	
	<p><b>Children have died from furniture tipover. To reduce the risk of furniture tipover:</b></p> <ul style="list-style-type: none"><li>● <b>ALWAYS</b> install tipover restraint provided.</li><li>● <b>NEVER</b> put a TV on this product.</li><li>● <b>NEVER</b> allow children to stand, climb or hang on drawers, doors, or shelves.</li><li>● <b>NEVER</b> open more than one drawer at a time.</li><li>● <b>Place heaviest items in the lowest drawers.</b></li></ul>
	

# Parts List (EN)/Teile Liste(DE)

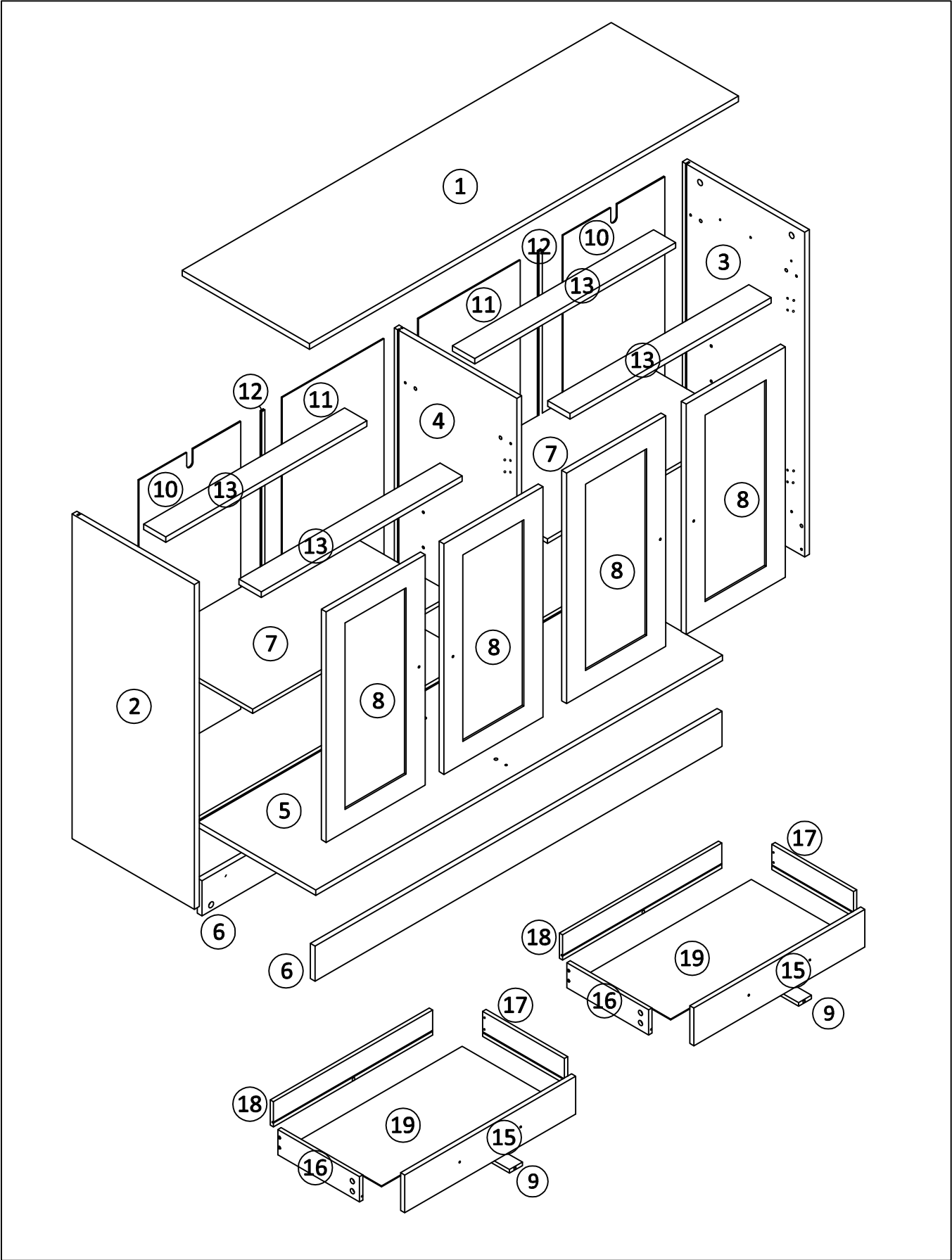



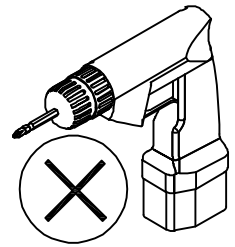
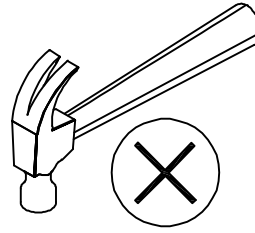
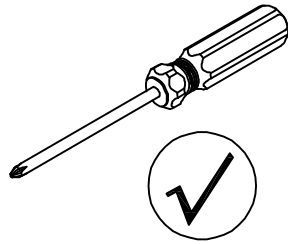
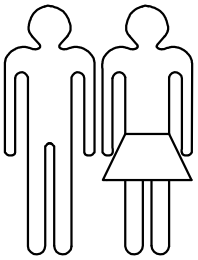





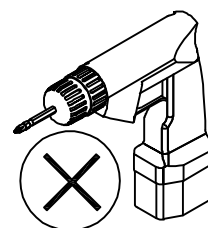
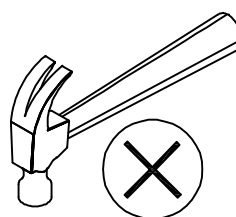
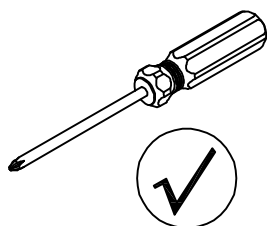
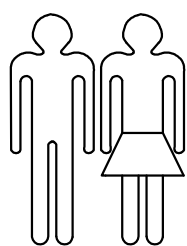

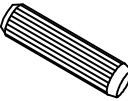

# Parts List (EN)/Teile Liste(DE)

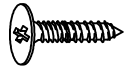

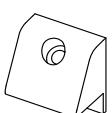
<p><b>1</b></p> <p>1250*400*15mm <b>1PC</b></p>	<p><b>2</b></p> <p>885*370*15mm <b>1PC</b></p>	<p><b>3</b></p> <p>885*370*15mm <b>1PC</b></p>	<p><b>4</b></p> <p>790*368*15mm <b>1PC</b></p>
<p><b>5</b></p> <p>1189*368*15mm <b>1PC</b></p>	<p><b>6</b></p> <p>1189*79*15mm <b>2PCS</b></p>	<p><b>7</b></p> <p>585.5*332*12mm <b>2PCS</b></p>	<p><b>8</b></p> <p>613*289*15mm <b>4 PCS</b></p>
<p><b>9</b></p> <p>284*50*15mm <b>2PCS</b></p>	<p><b>10</b></p> <p>799.5*297.5*3mm <b>2PCS</b></p>	<p><b>11</b></p> <p>799.5*297.5*3mm <b>2PCS</b></p>	<p><b>12</b></p> <p>788*10*5mm <b>2PCS</b></p>
<p><b>13</b></p> <p>589*80*15mm <b>4PCS</b></p>	<p><b>15</b></p> <p>581*150*15mm <b>2PCS</b></p>	<p><b>16</b></p> <p>300*116*15mm <b>2PCS</b></p>	<p><b>17</b></p> <p>300*116*15mm <b>2PCS</b></p>
<p><b>18</b></p> <p>532*116*15mm <b>2PCS</b></p>	<p><b>19</b></p> <p>540.5*293*3mm <b>2PCS</b></p>		

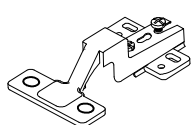
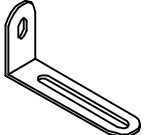
## Hardware List (EN)/Teile Liste(DE)

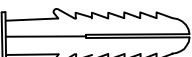
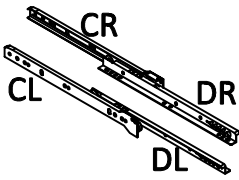
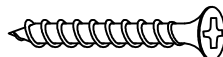
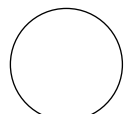
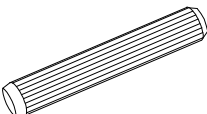

<p><b>A</b></p>  <p><b>Ø15*9mm 42 PCS</b></p>	<p><b>B</b></p>  <p><b>Ø6*35mm 42 PCS</b></p>	<p><b>C</b></p>  <p><b>Ø8*30mm 20PCS</b></p>	<p><b>D</b></p>  <p><b>M4*20mm 8PCS</b></p>
<p><b>E</b></p>  <p><b>φ30*20mm 8PCS</b></p>	<p><b>F</b></p>  <p><b>Ø3.5*14mm 50PCS</b></p>	<p><b>G</b></p>  <p><b>Ø10*3mm 4PCS</b></p>	<p><b>H</b></p>  <p><b>Ø6*17mm 8PCS</b></p>
<p><b>I</b></p>  <p><b>16*16*11mm 8PCS</b></p>	<p><b>J</b></p>  <p><b>Ø3*15mm 8PCS</b></p>	<p><b>K</b></p>  <p><b>Ø35 8PCS</b></p>	<p><b>L</b></p>  <p><b>65*15*35mm 2PCS</b></p>
<p><b>M</b></p>  <p><b>Ø4*40mm 2PCS</b></p>	<p><b>N</b></p>  <p><b>Ø 6*30 mm 2PCS</b></p>	<p><b>O</b></p>  <p><b>12" 2PCS</b></p>	<p><b>P</b></p>  <p><b>Ø4*35mm 8 PCS</b></p>
<p><b>Q</b></p>  <p><b>25PCS</b></p>	<p><b>R</b></p>  <p><b>Ø8*50mm 2PCS</b></p>	<p><b>S</b></p>  <p><b>Ø3*12mm 24 PCS</b></p>	

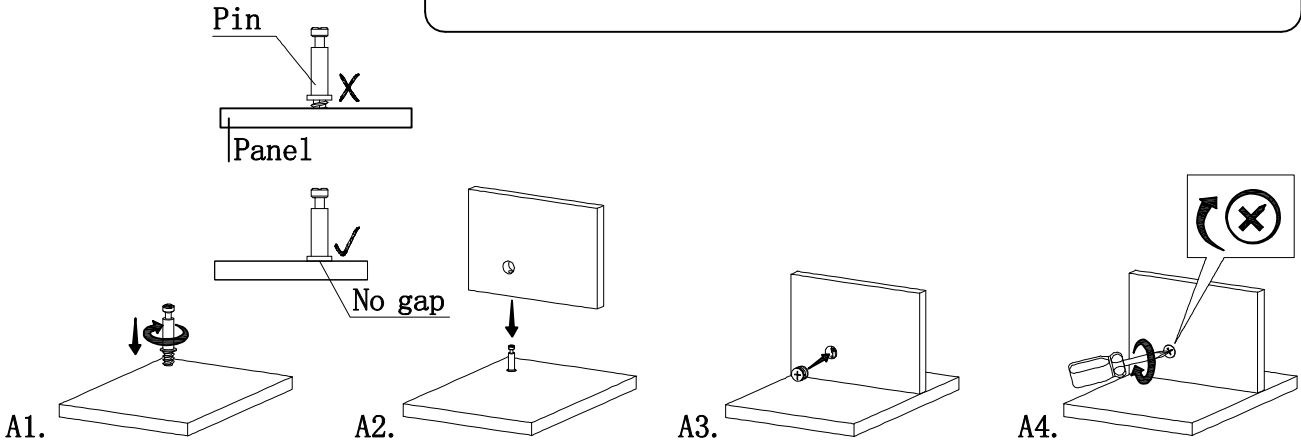
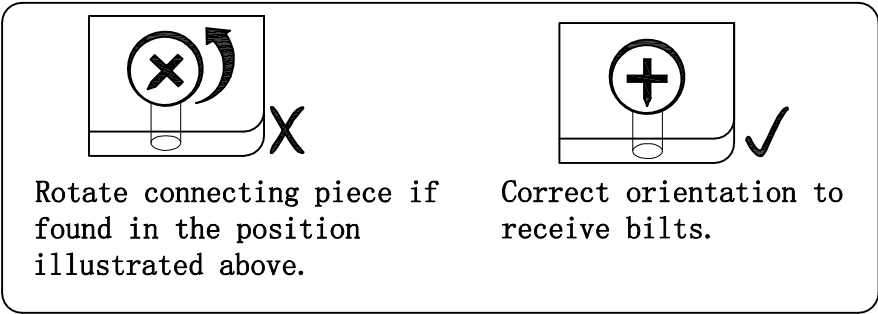
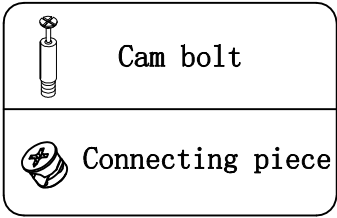

# CAM BOLT INSTALLATION AS BELOW:

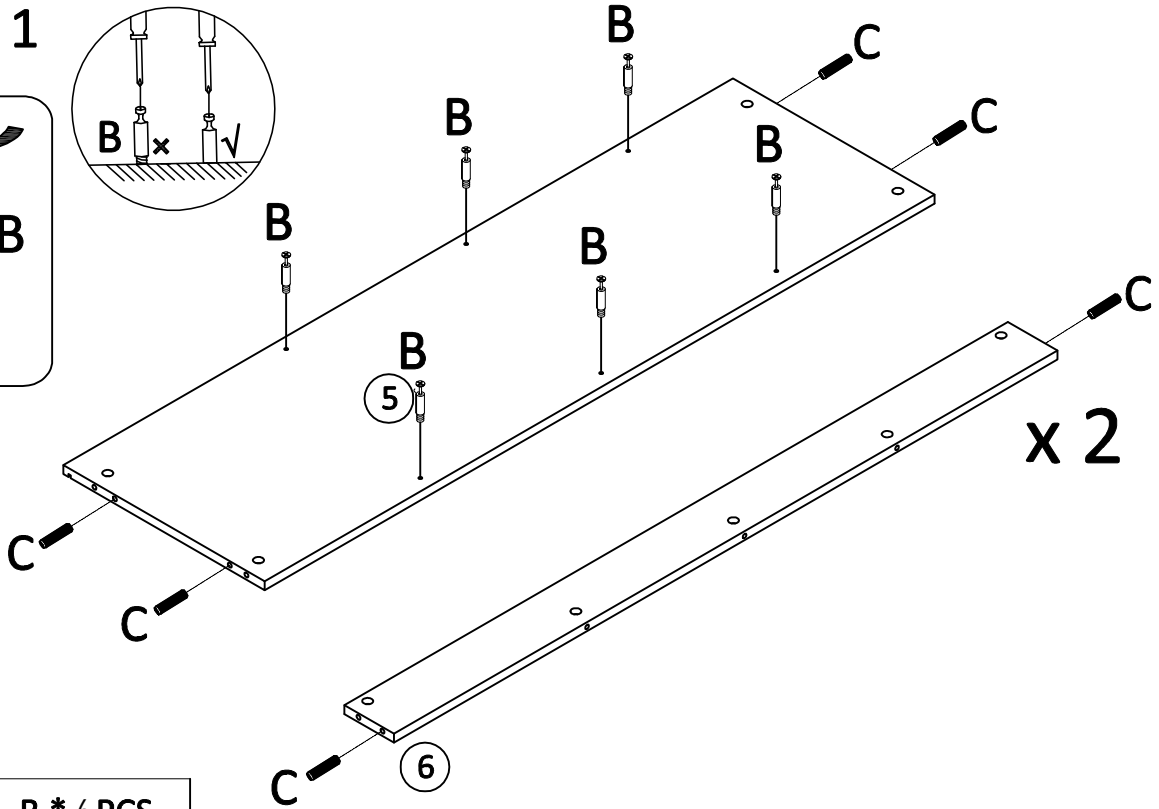
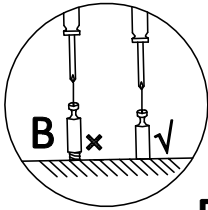
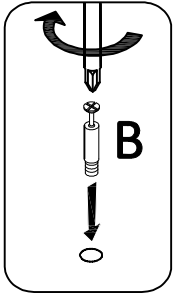

# Assembly (EN)/Montageschritte(DE)

## STEP 1

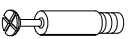

	B * 6 PCS
	C * 8 PCS

## STEP 2

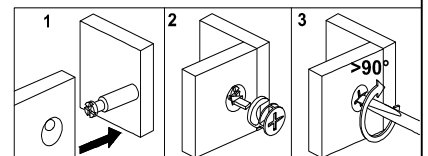
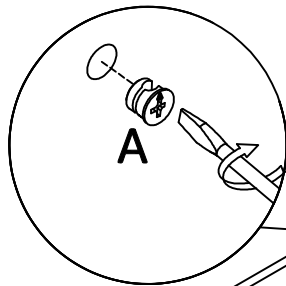
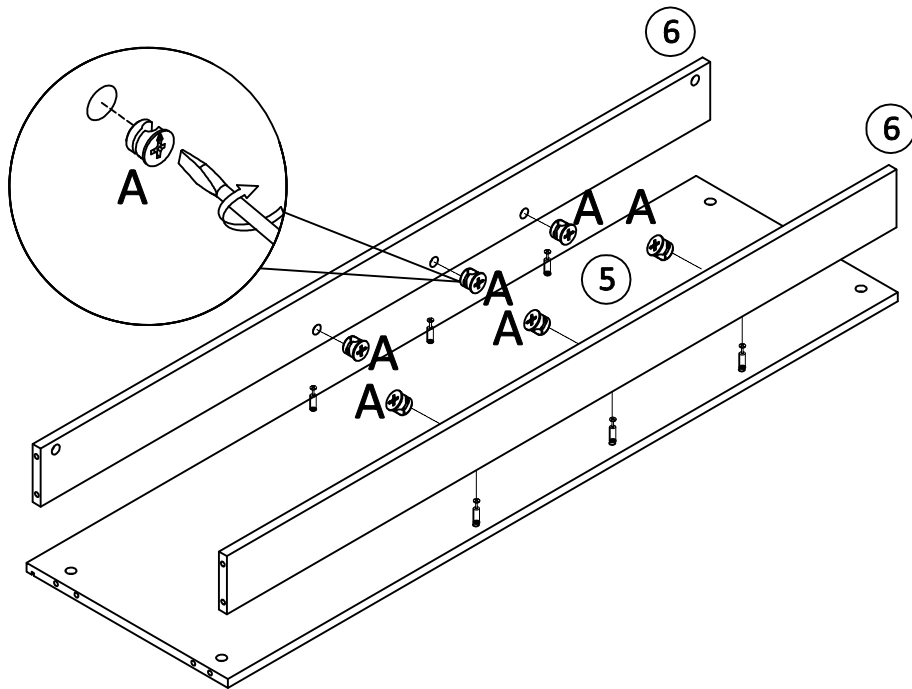

	A * 6 PCS
---	-----------

# Assembly (EN)/Montageschritte(DE)

## STEP 3

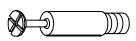
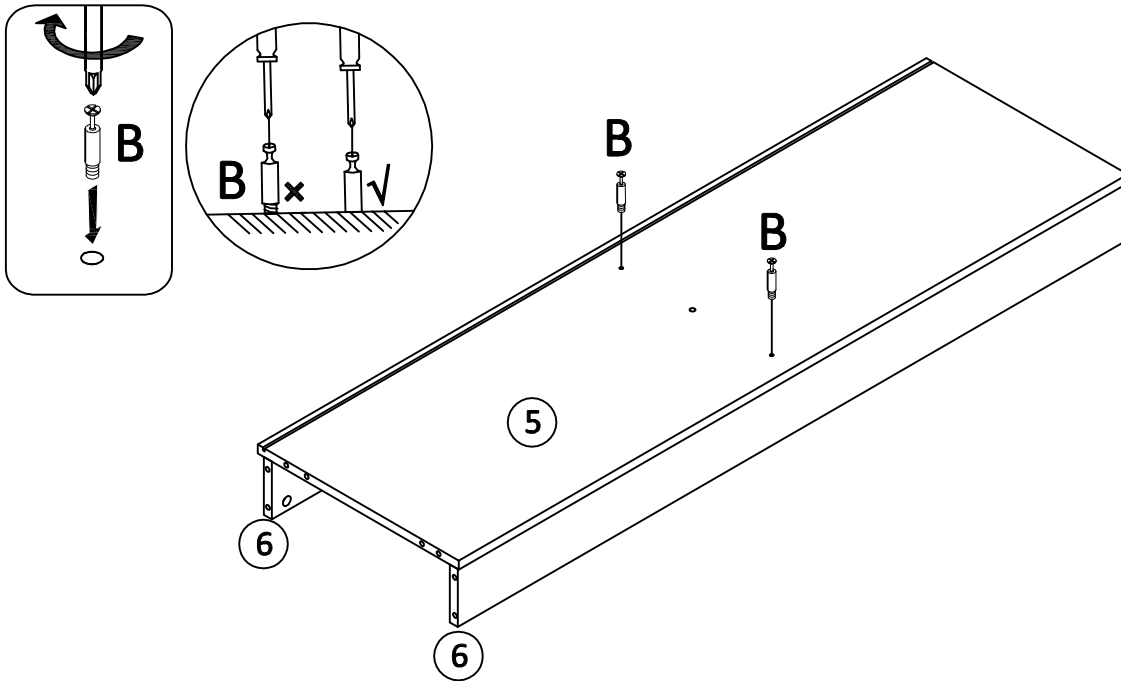

B \* 2PCS

## STEP 4

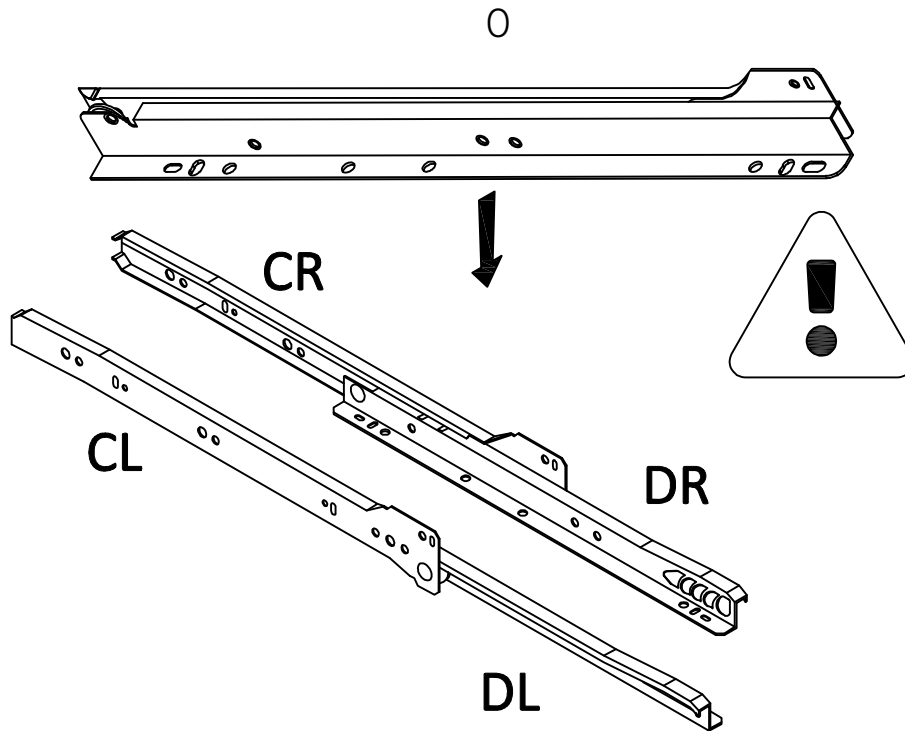

# Assembly (EN)/Montageschritte(DE)

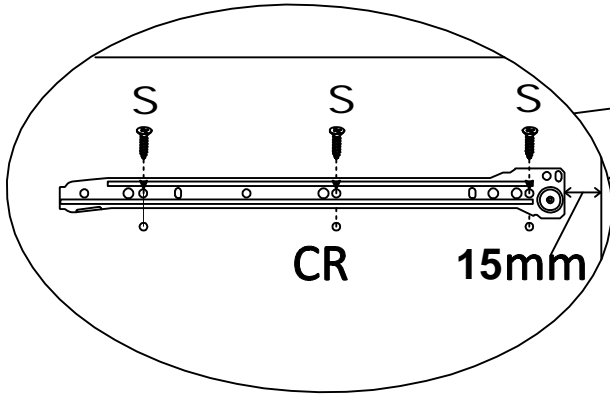

## STEP 5

Lock the slides on to the plate according to the holes shown in the illustration.

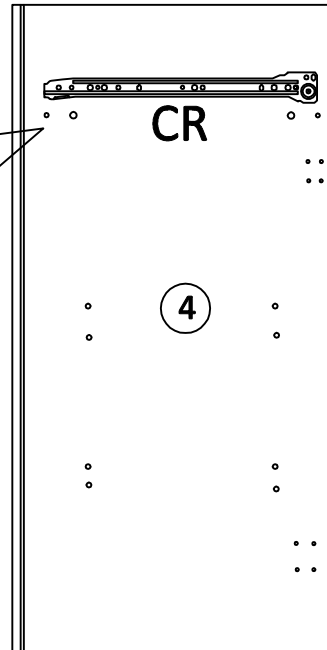

one side



	S * 3PCS
	CR * 1PC

## STEP 6

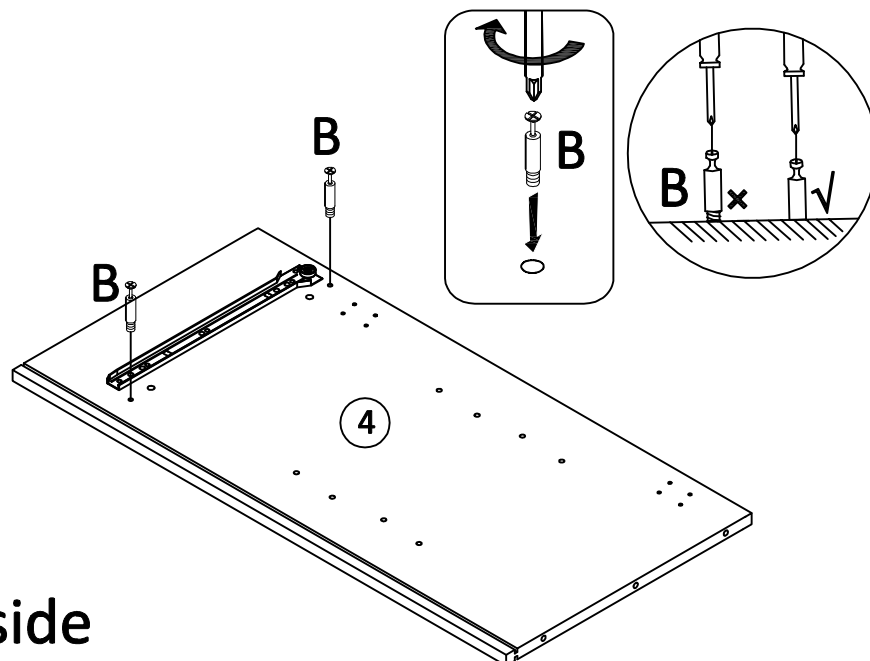

one side

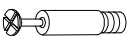
	B * 2PCS
---	----------



# Assembly (EN)/Montageschritte(DE)

## STEP 7

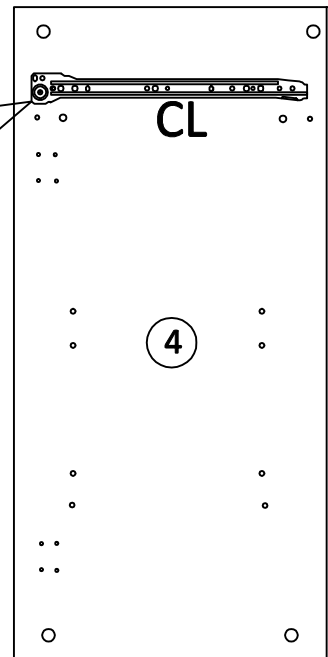
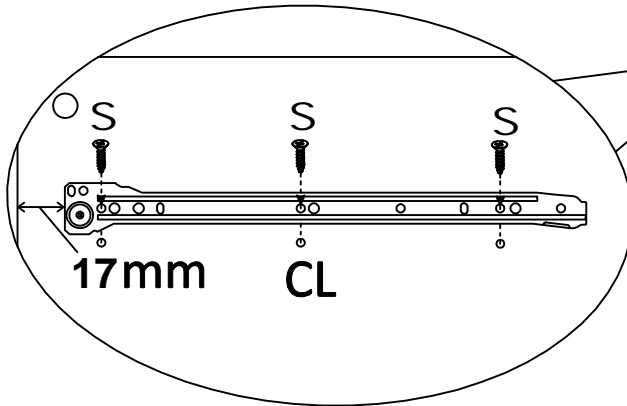
Lock the slides on to the plate according to the holes shown in the illustration.





the other side

	S * 3PCS
	CL * 1PC

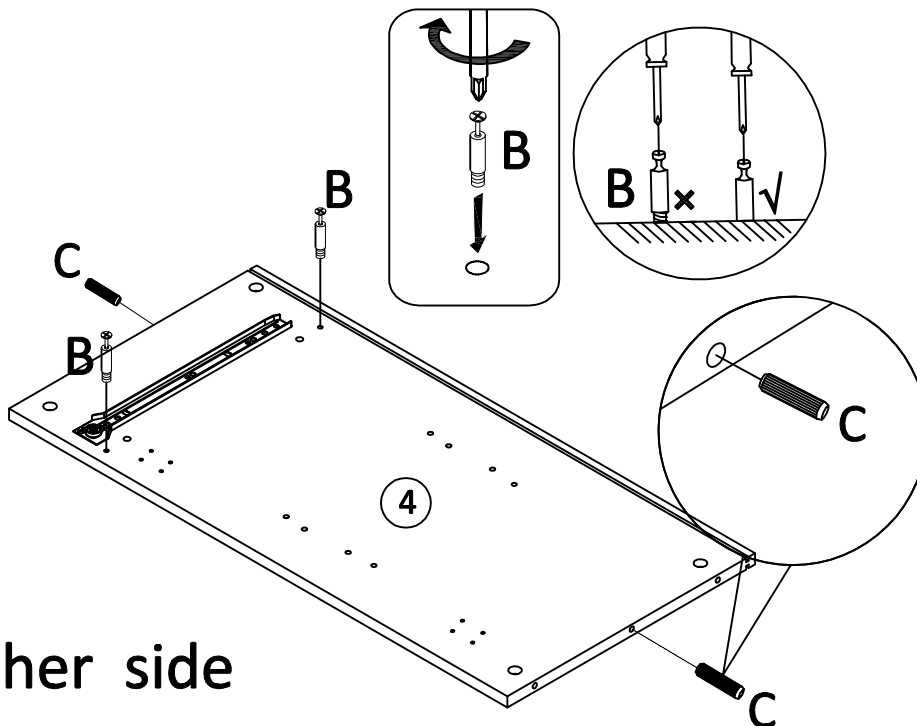
## STEP 8



the other side



	B * 2PCS
	C * 2PCS

# Assembly (EN)/Montageschritte(DE)

## STEP 9

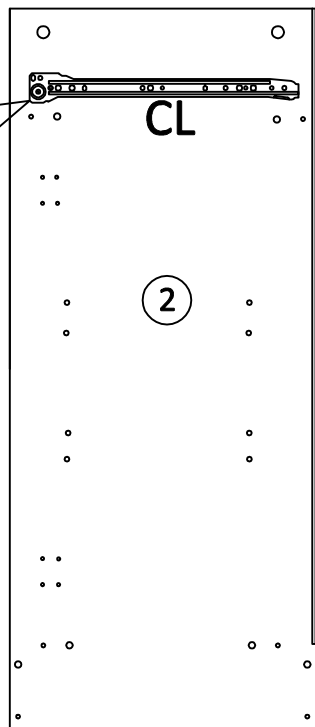
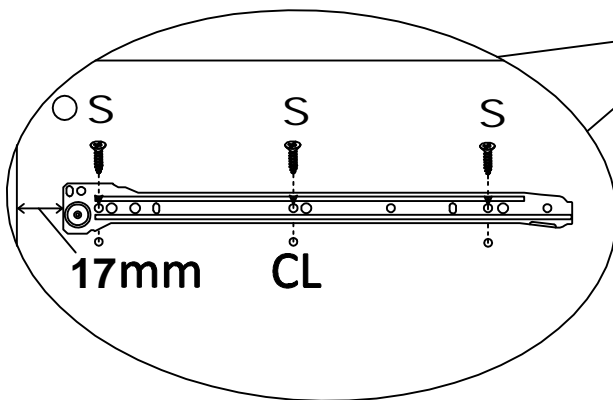

Lock the slides on to the plate according to the holes shown in the illustration.

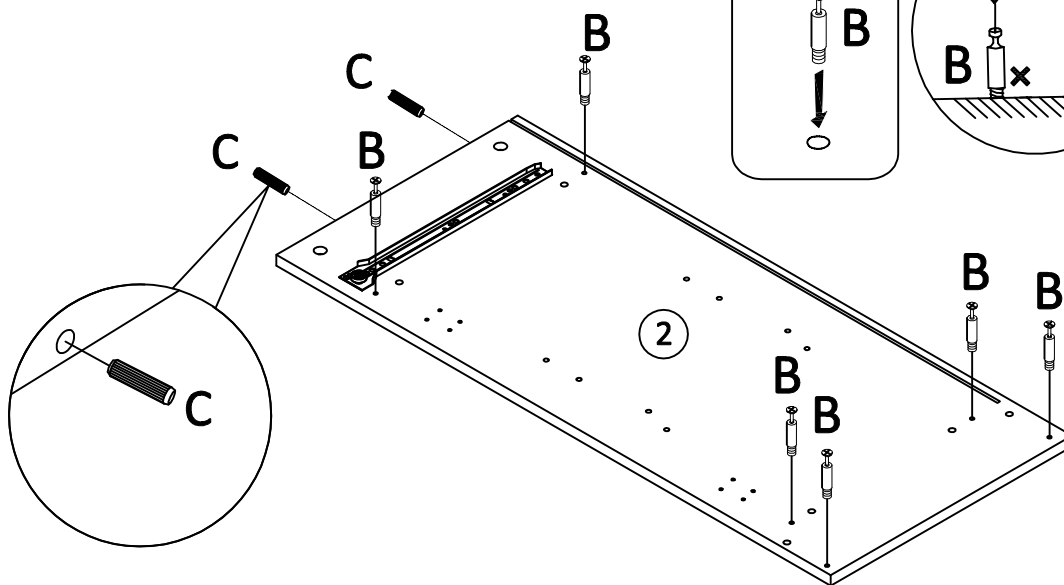

	S * 3PCS
	CL * 1PC

## STEP 10

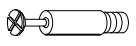



	B * 6PCS
	C * 2PCS

# Assembly (EN)/Montageschritte(DE)

## STEP 11

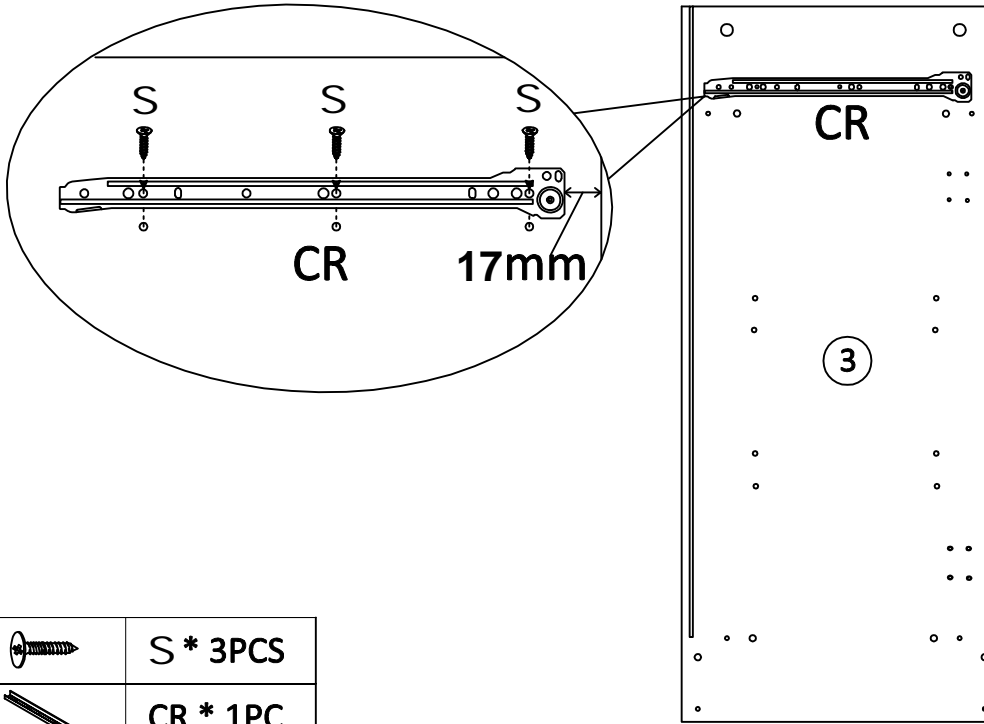

Lock the slides on to the plate according to the holes shown in the illustration.

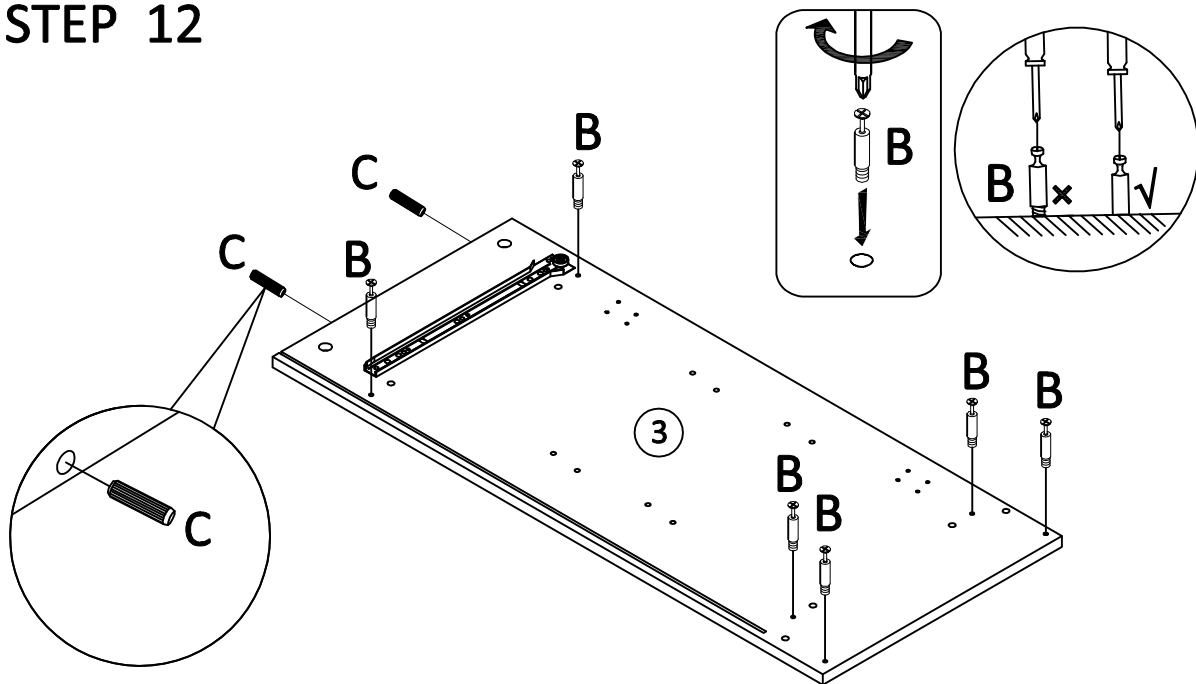

	S * 3PCS
	CR * 1PC

## STEP 12

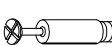

	B * 6PCS
	C * 2PCS

# Assembly (EN)/Montageschritte(DE)

## STEP 13

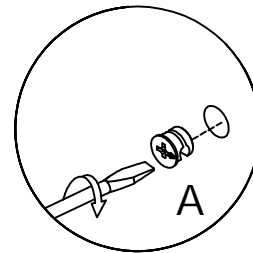
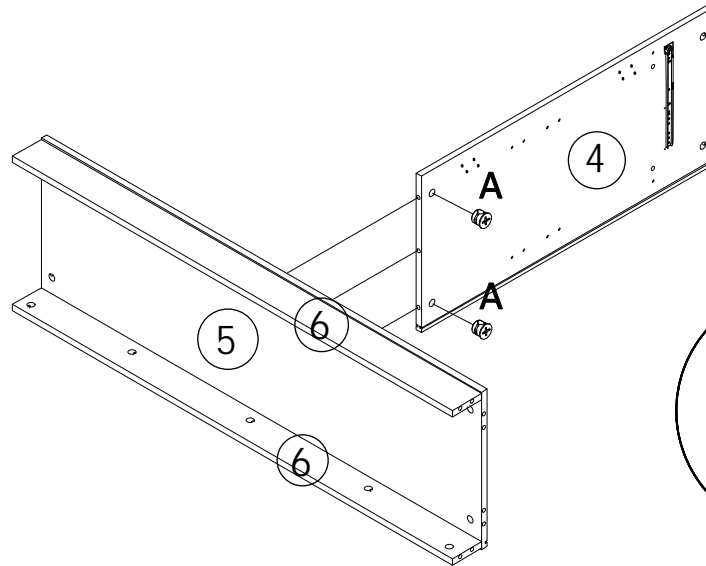
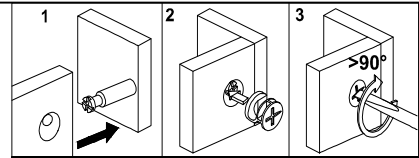

A \* 2PCS

## STEP 14

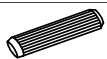
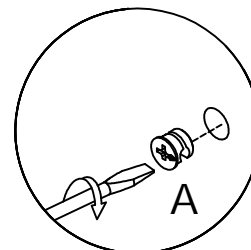
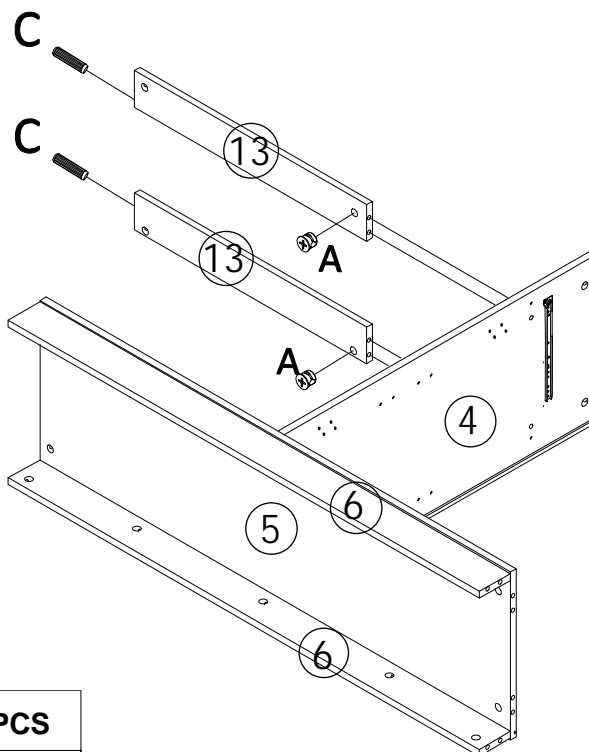
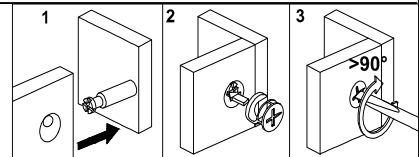

C \* 2PCS



A \* 2PCS

# Assembly (EN)/Montageschritte(DE)

## STEP 15

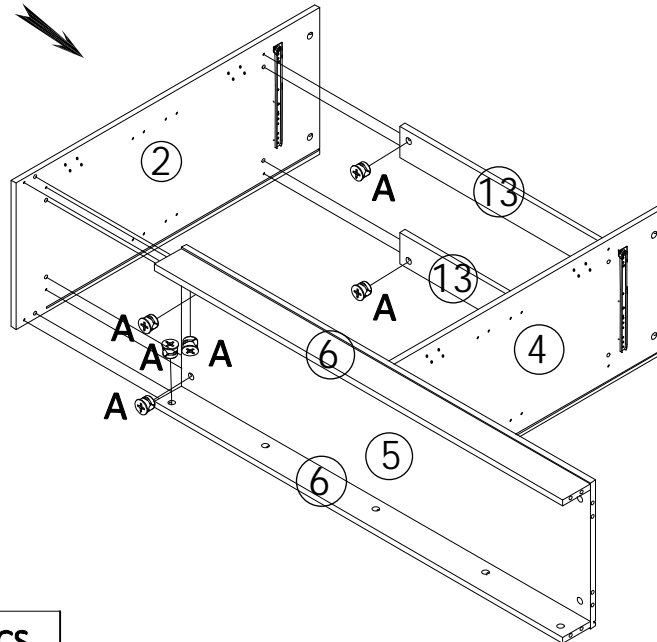
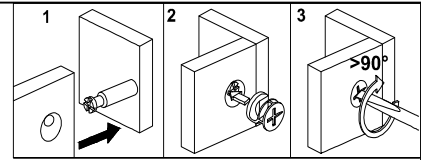

A \* 6PCS

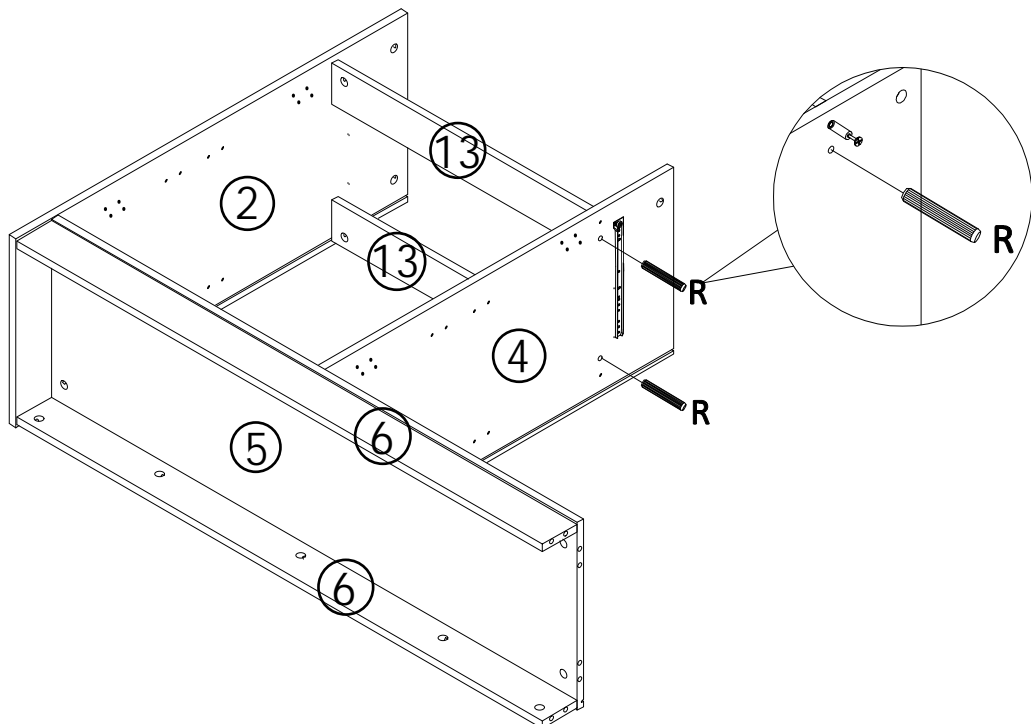

## STEP 16

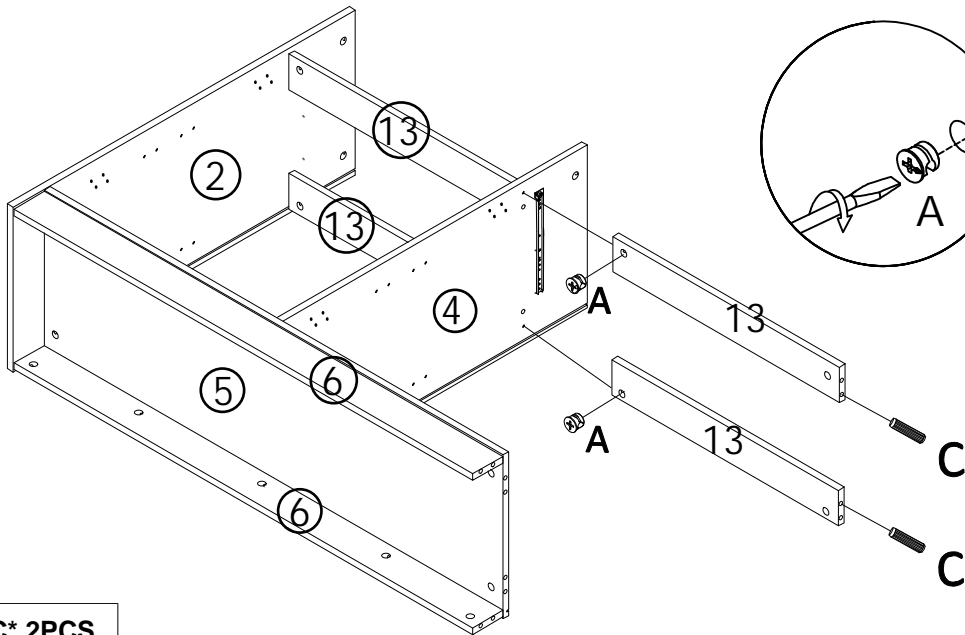
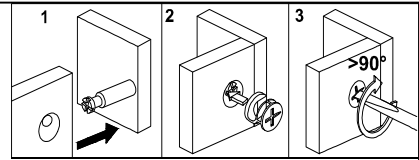

R \* 2PCS

STEP 17



	<b>C * 2PCS</b>
	<b>A * 2 PCS</b>

STEP 18

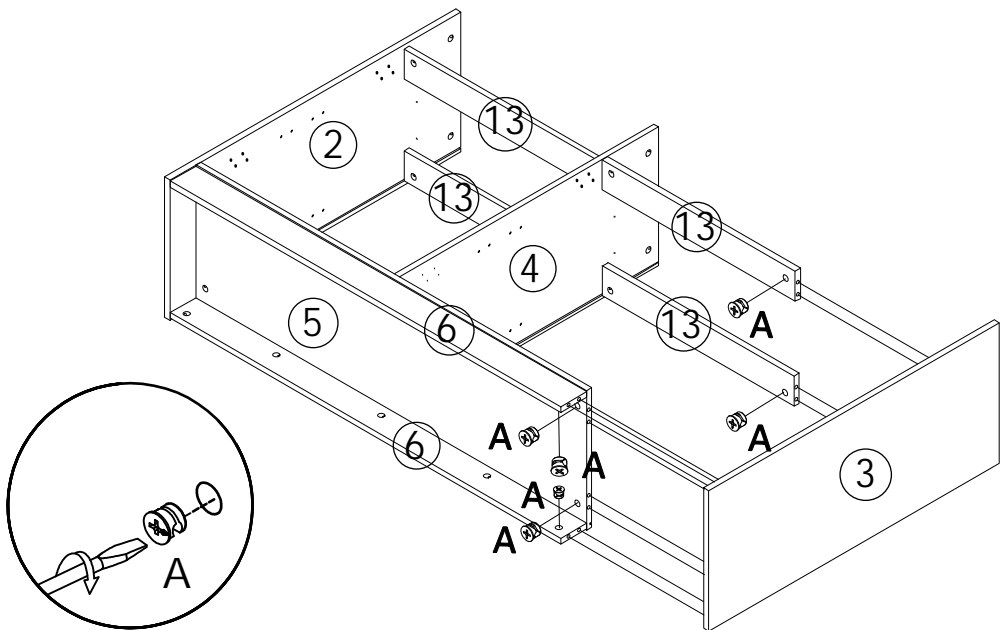
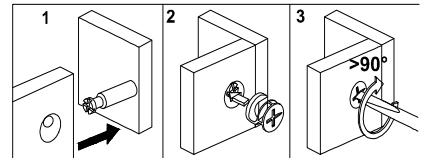

	<b>A * 6PCS</b>
---	-----------------

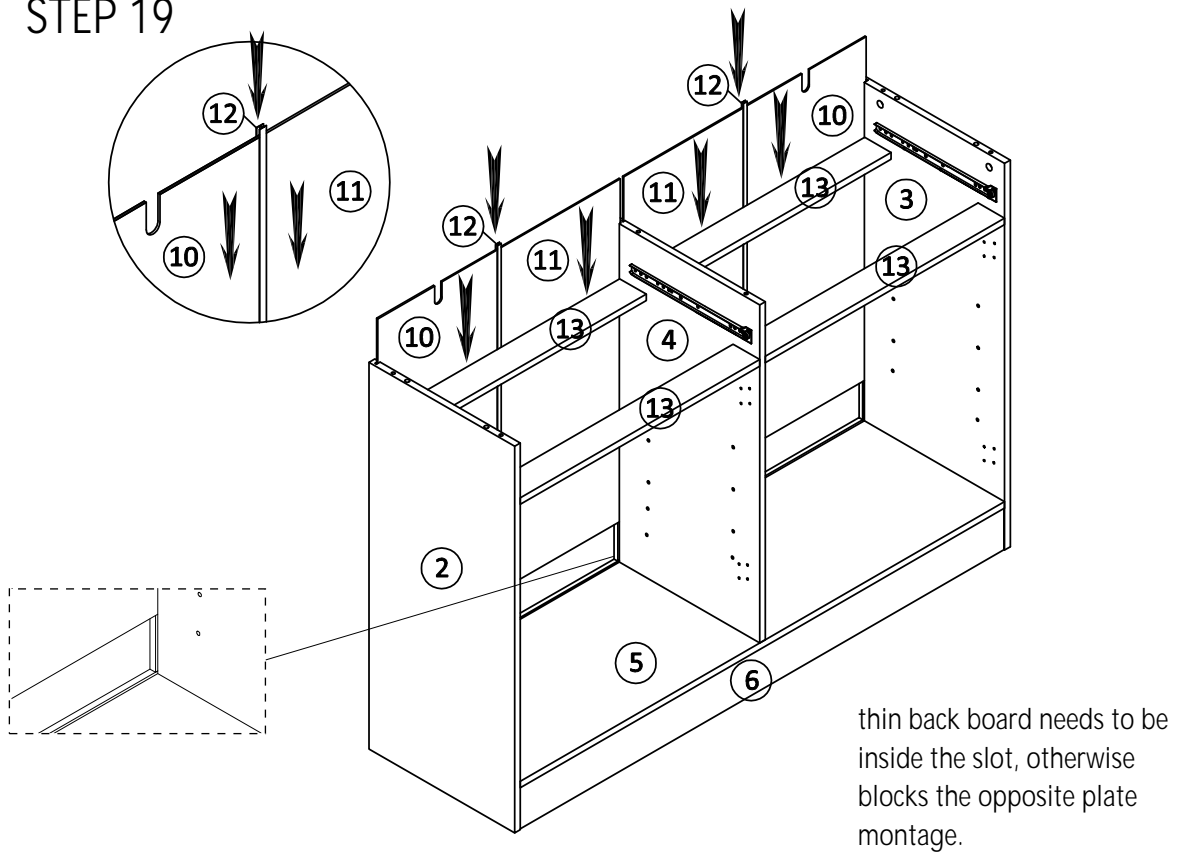

# Assembly (EN)/Montageschritte(DE)

## STEP 19

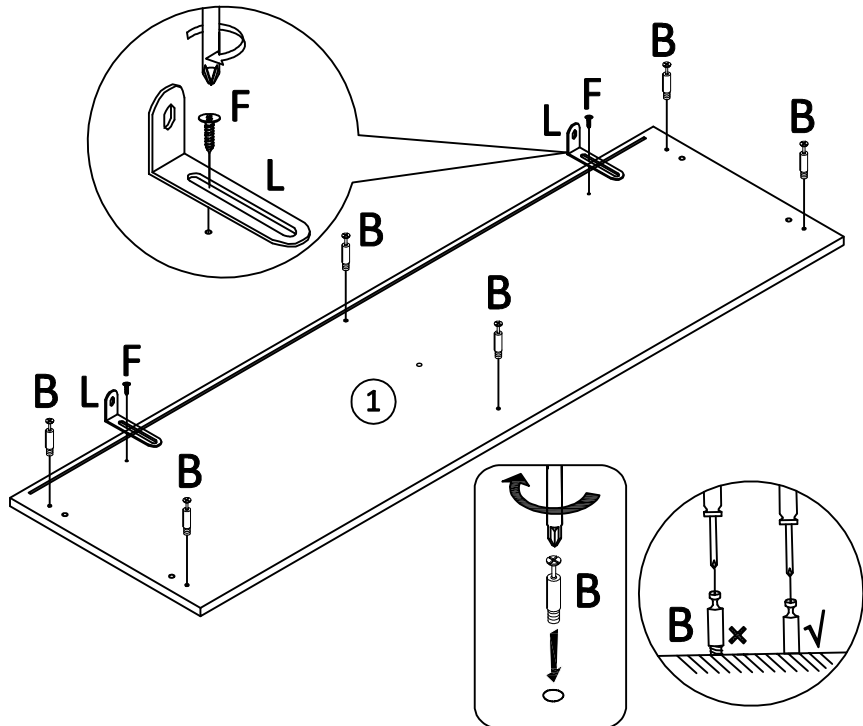

## STEP 20

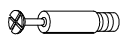



	B * 6PCS
	F * 2PCS
	L * 2PCS

# Assembly (EN)/Montageschritte(DE)

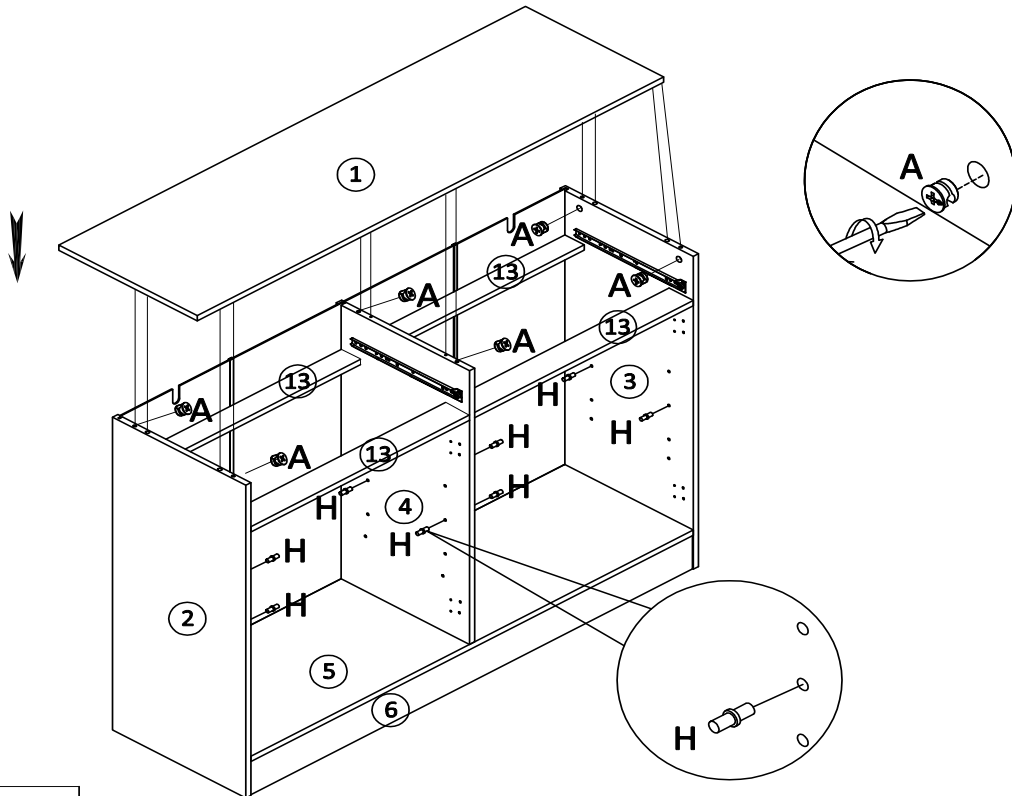
STEP 21





	A * 6PCS
	H * 8PCS

-15-

STEP 22

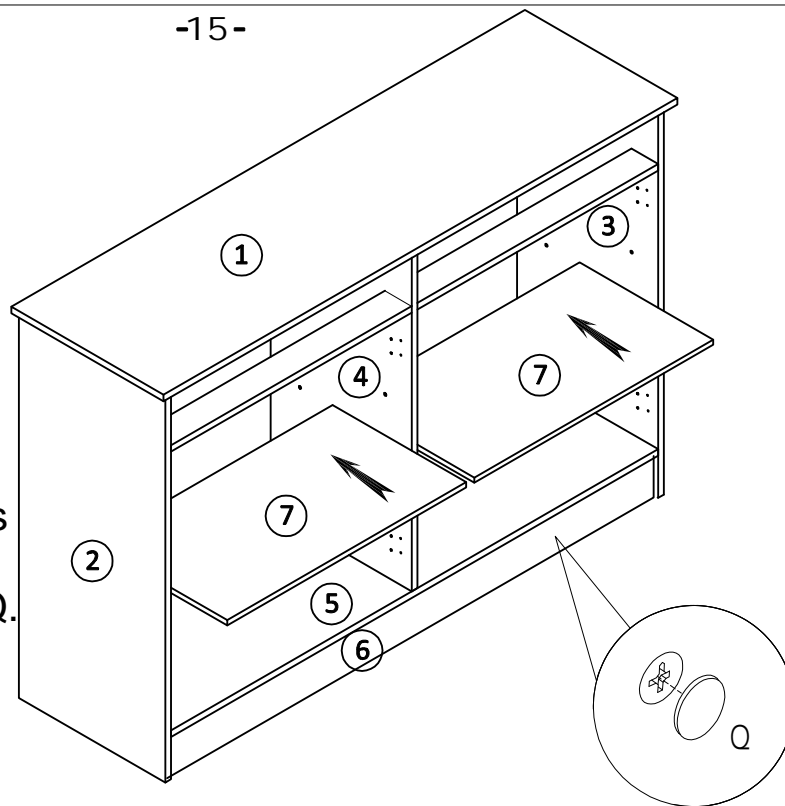
The upper and lower holes in these three places can be attached with hole sticker Q.



	Q * 25 PCS
---	------------



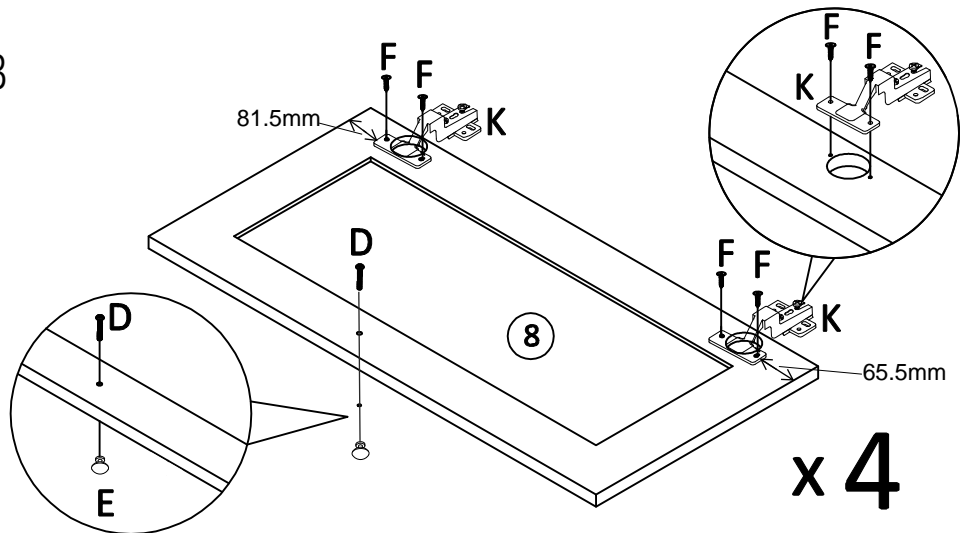

-16-

# Assembly (EN)/Montageschritte(DE)

STEP 23





x 4

	D * 4 PCS		F * 16PCS
	E * 4 PCS		K * 8PCS

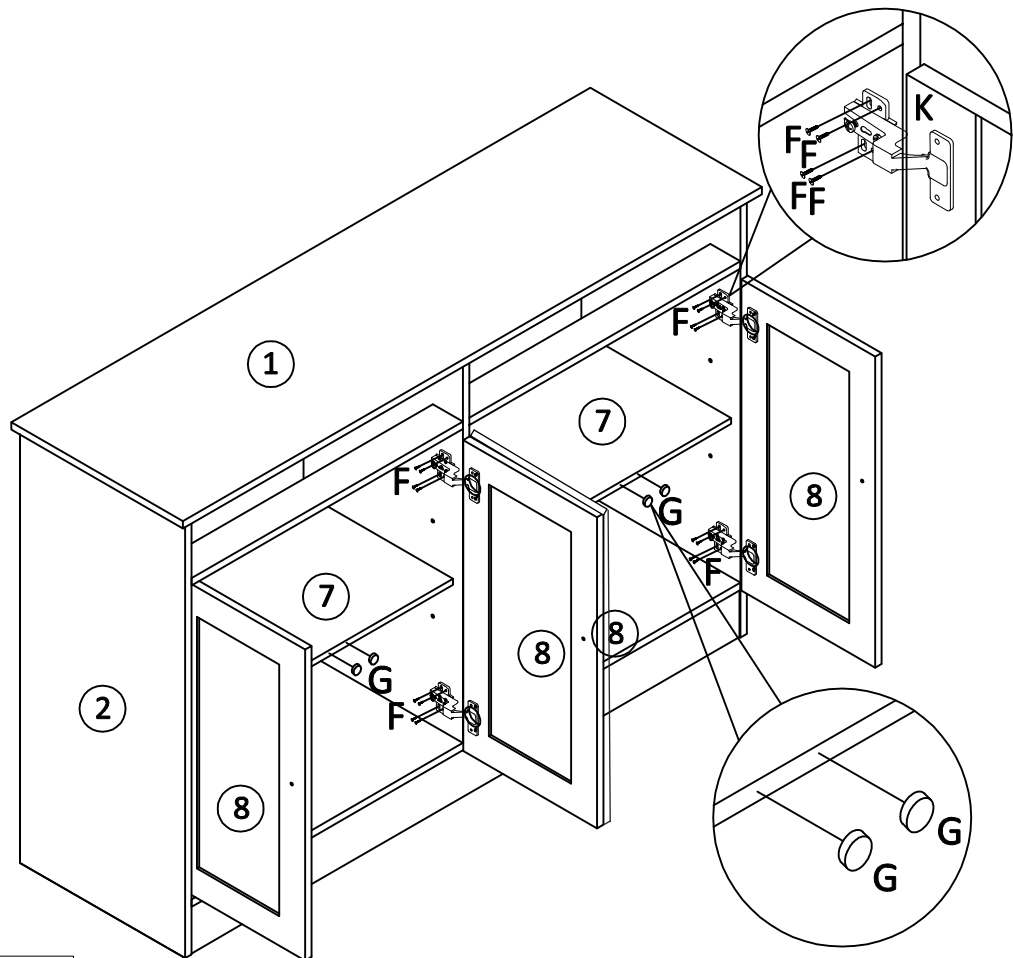
STEP 24



	F * 32PCS
	G * 4PCS

# Assembly (EN)/Montageschritte(DE)

## STEP 25



NOTE : If you notice that the cabinet doors are not properly aligned, such as significant gaps or vertical or horizontal misalignment, please adhere to the following adjustment instructions.

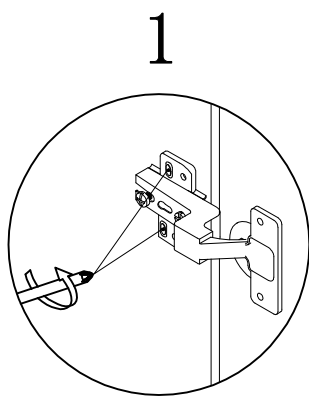
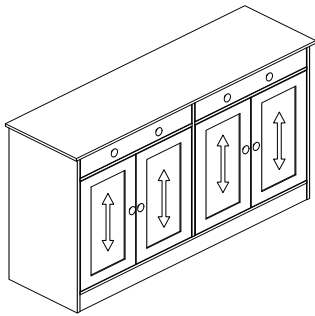

lose these 2 screws

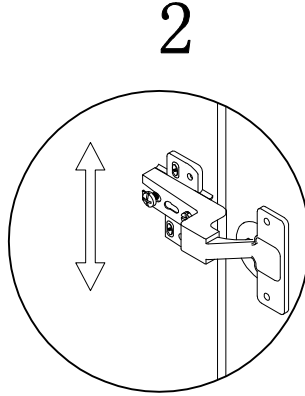

move hinge up/down

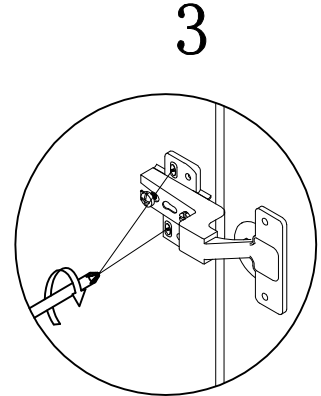

tighten these 2 screws again

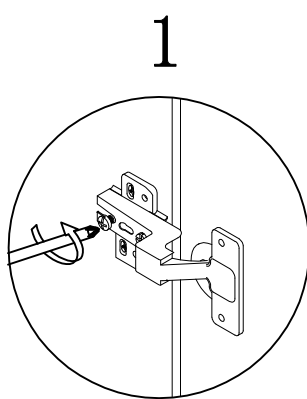
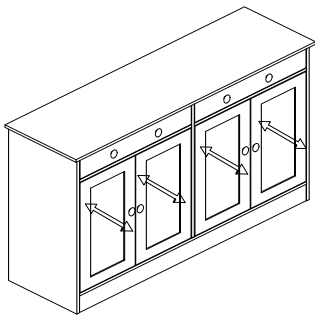

lose this screw

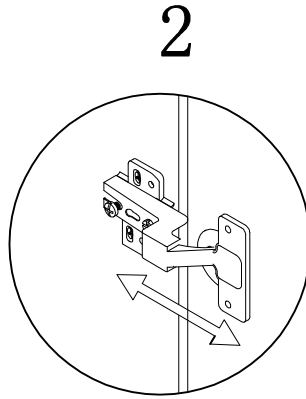

shift hinge in/out

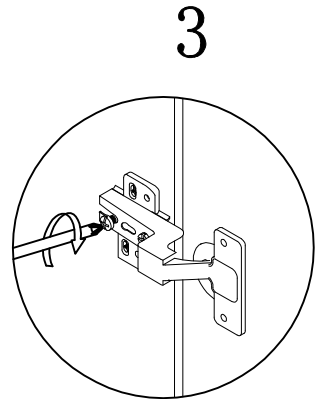

tighten this screw again

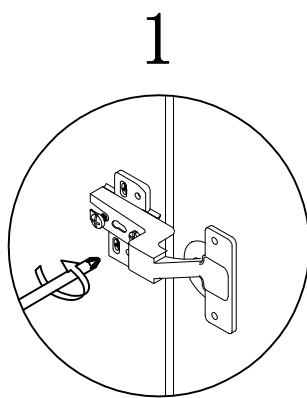
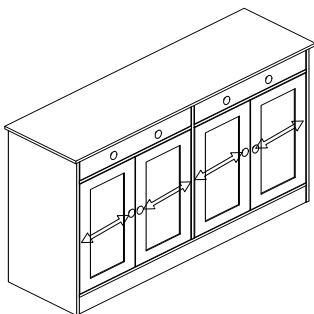

lose this screw would get hinge/door closer to side board

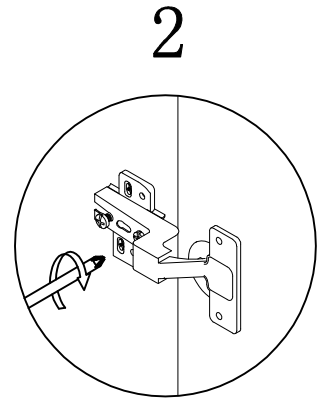

tighten this screw would get hinge/door away from side board

# Assembly (EN)/Montageschritte(DE)

STEP 26

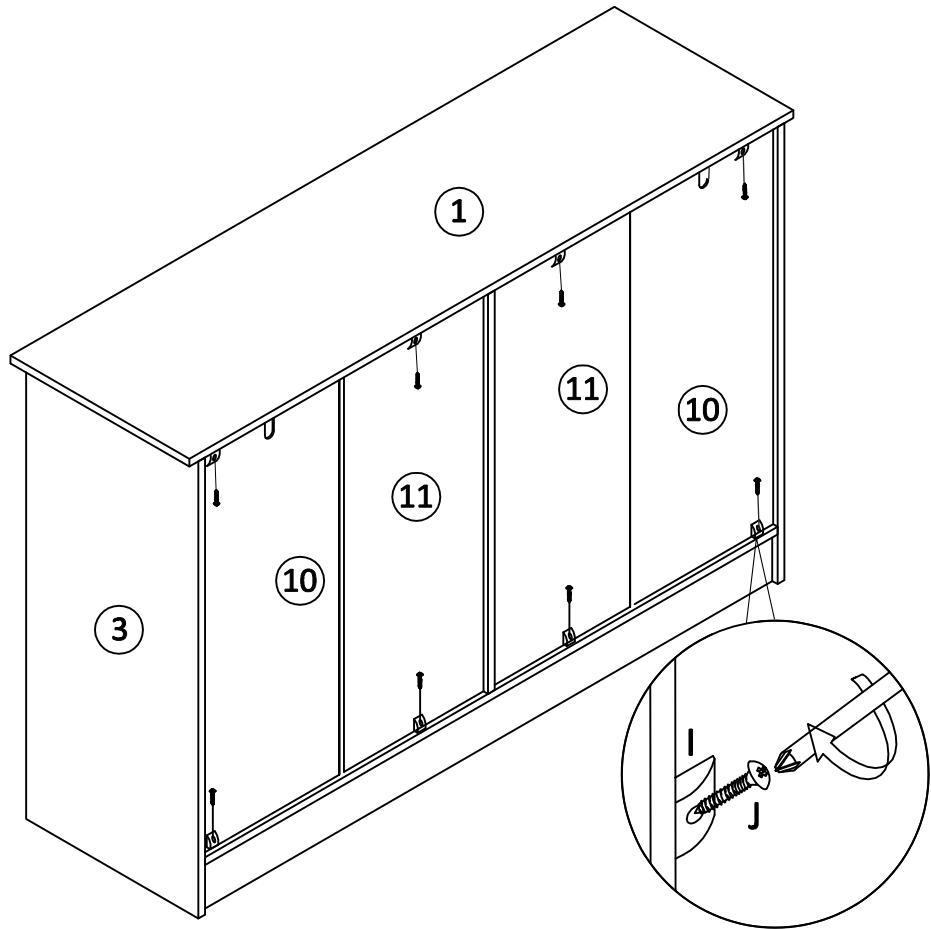

I \* 8PCS



J \* 8PCS

STEP 27

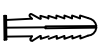
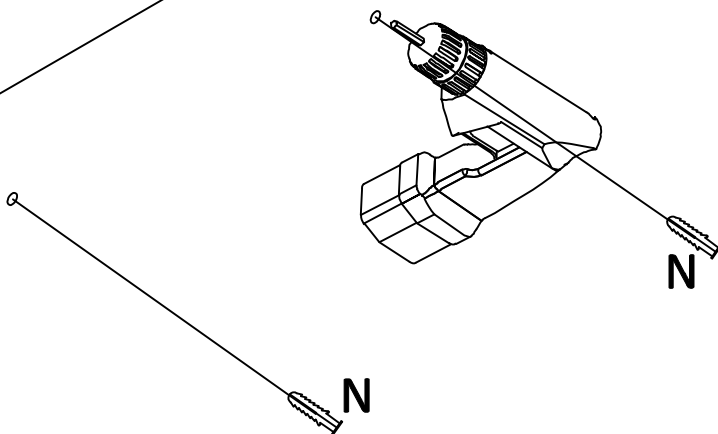

N \* 2PCS

# Assembly (EN)/Montageschritte(DE)

## STEP 28

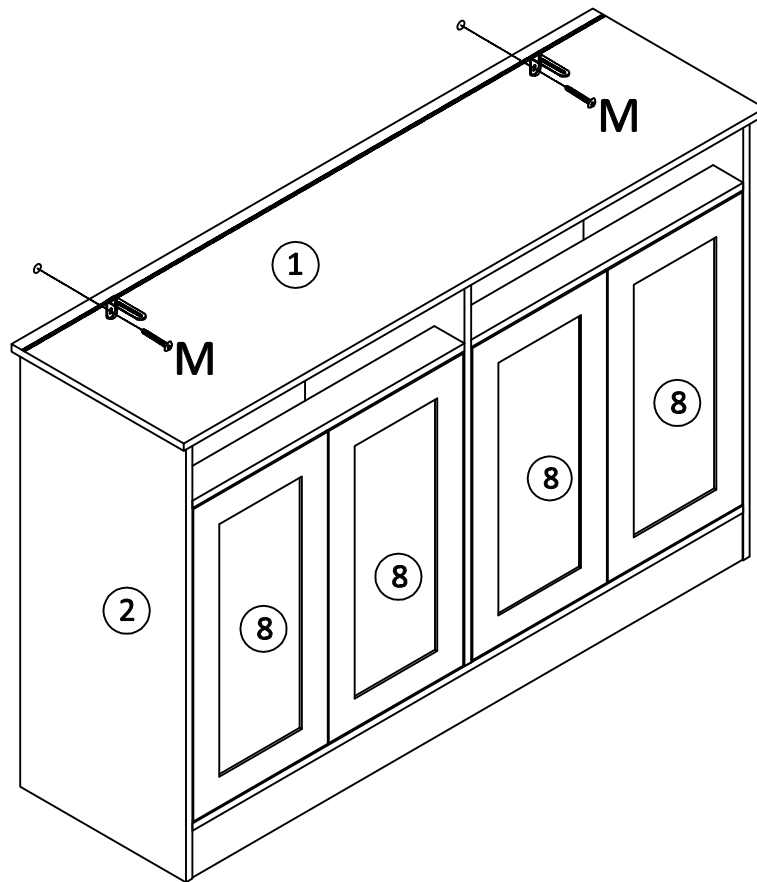
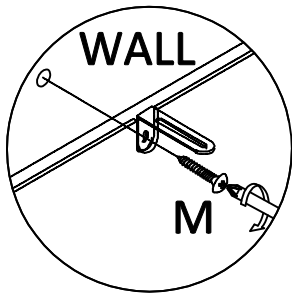

Note: Toppling preventer must be installed otherwise there is a risk of tipping.



M \*2PCS

## STEP 29

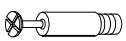
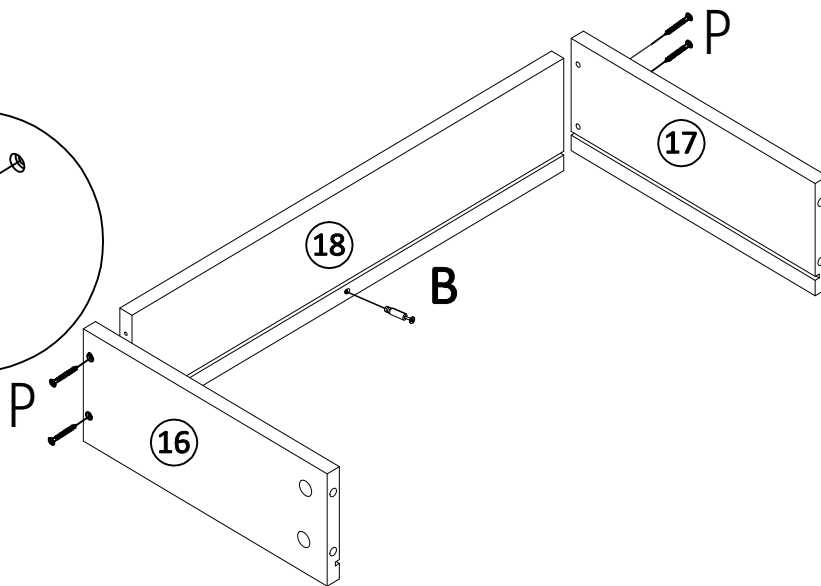
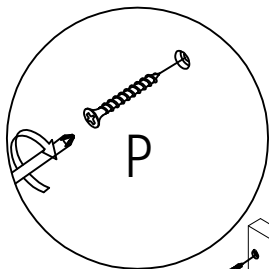

B \* 2 PCS

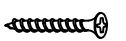

P \* 8 PCS

# Assembly (EN)/Montageschritte(DE)

## STEP 30

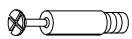
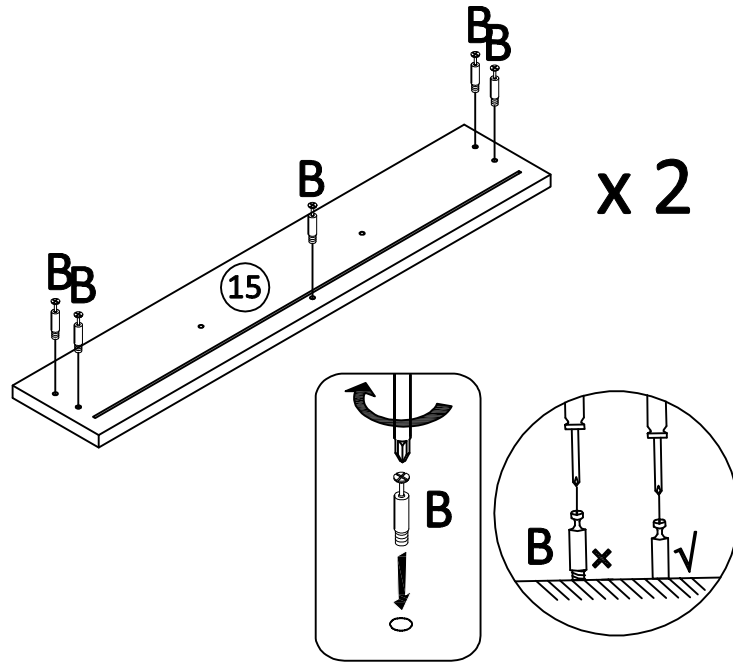

**B \*10PCS**

## STEP 31

thin back board needs to be inside the slot, otherwise blocks the opposite plate montage.

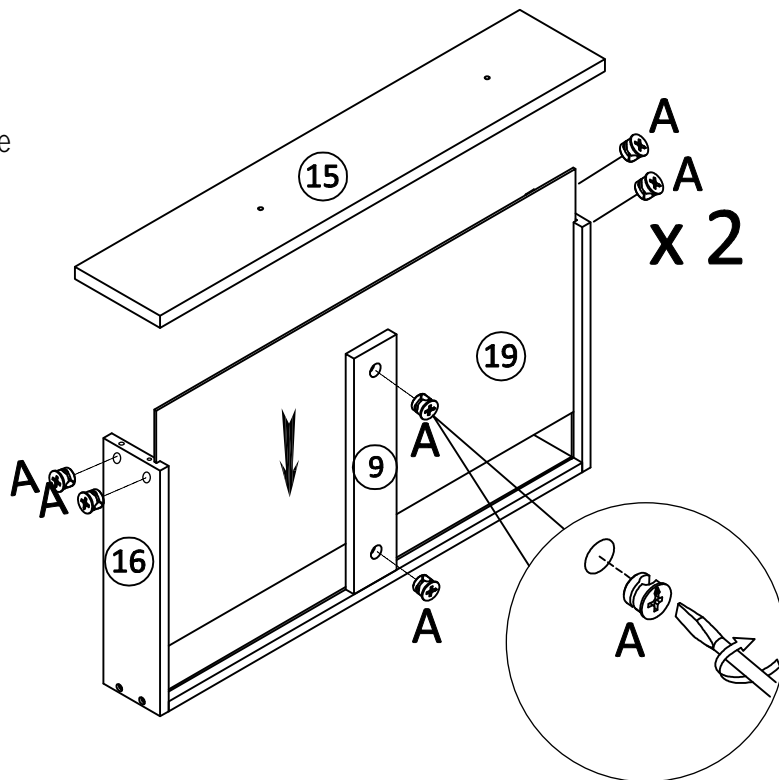



**A \*12PCS**

# Assembly (EN)/Montageschritte(DE)

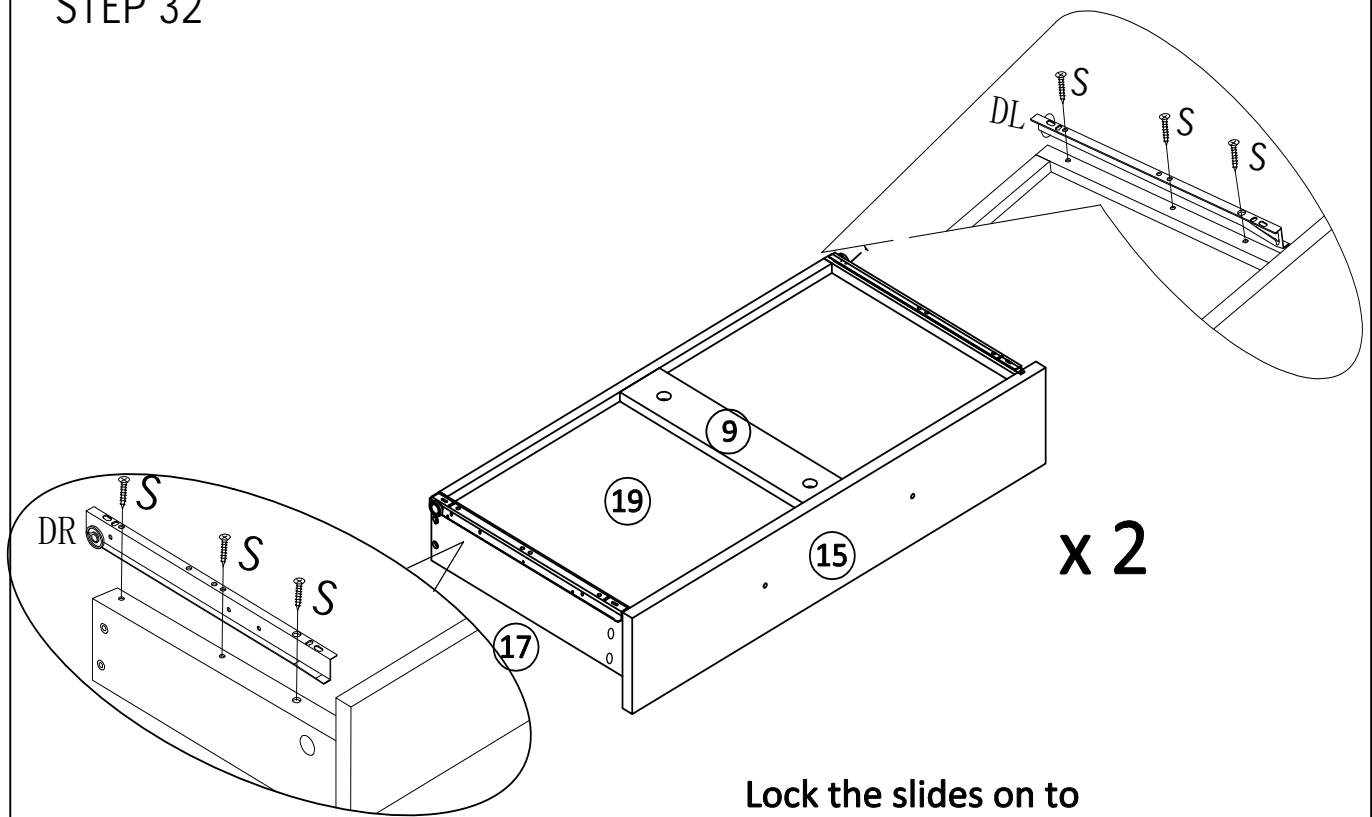
## STEP 32





	S * 12PCS
	DL * 2PCS
	DR * 2PCS

Lock the slides on to the plate according to the holes shown in the illustration.

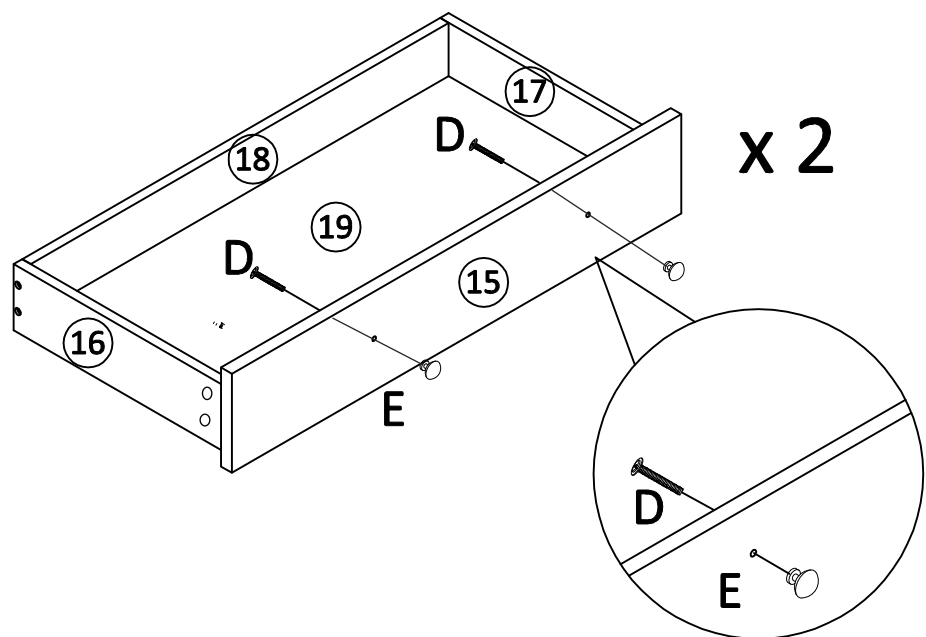
## STEP 33



	D * 4PCS
	E * 4PCS

# Assembly (EN)/Montageschritte(DE)

## STEP 34

The rollers on both sides should be fully seated in the slides as shown.

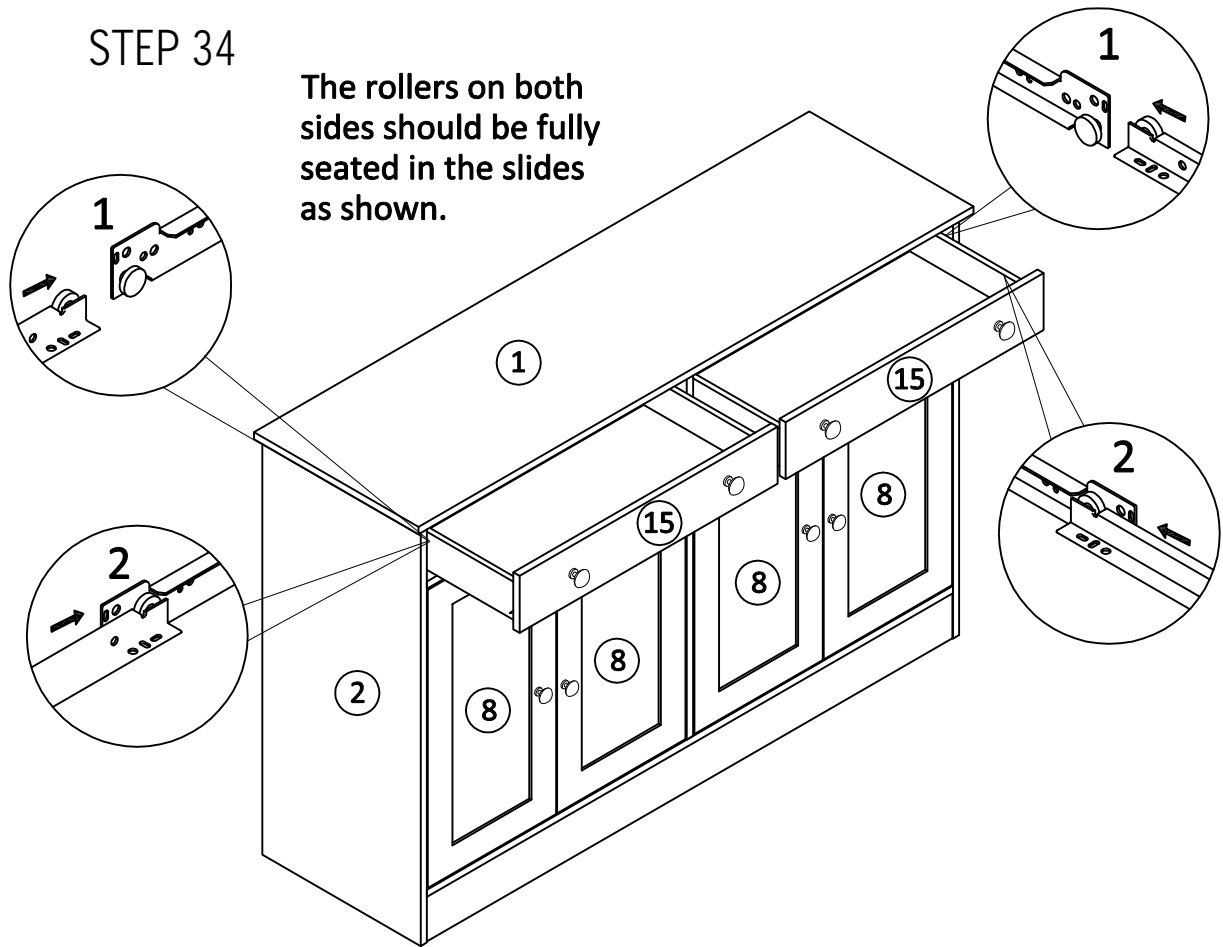

## STEP 35

