

# ASSEMBLY INSTRUCTIONS

Customer Service : [cs@nbrehome.com](mailto:cs@nbrehome.com)

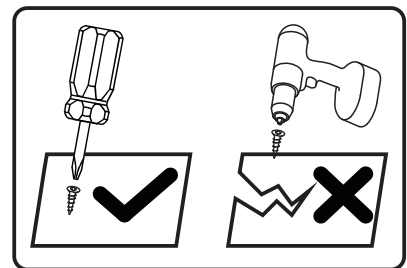
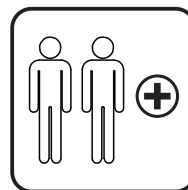
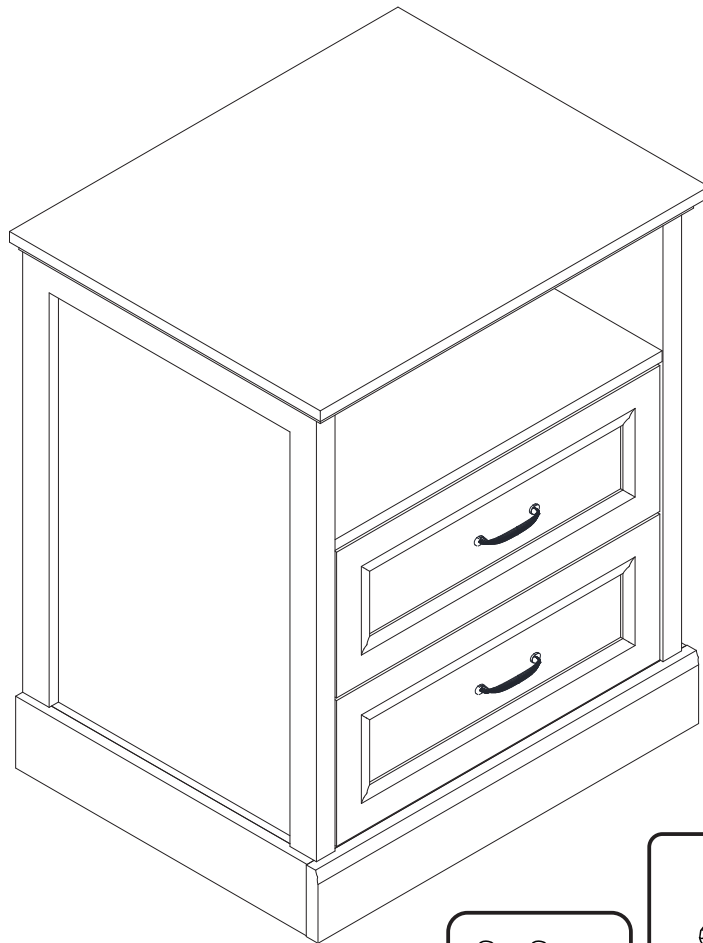

## Tools Recommended

THIS INSTRUCTIONS CONTAINS IMPORTANT SAFETY INFORMATION.  
PLEASE READ BEFORE ASSEMBLY AND KEEP FOR FUTURE REFERENCE.

Need Parts or Assistance? Email us : [cs@nbrehome.com](mailto:cs@nbrehome.com)

# IMPORTANT NOTICE

-This product contains small components, please ensure that they are kept away from small children.

-THIS INSTRUCTIONS CONTAINS IMPORTANT SAFETY INFORMATION.  
PLEASE READ BEFORE ASSEMBLY AND KEEP FOR FUTURE REFERENCE.

-Read each step carefully. It is very important that each step of instruction is performed in the correct order. If these steps are not followed in sequence, assembly difficulties will occur.

-Make sure all parts are included. Most parts are labelled or stamped on the raw edge.

-Work in spacious area, preferably on a carpet, near the place the unit will be used.

-Do not use power tools to assemble your furniture. Power tools may strip or damage the parts.

-Move your new furniture carefully, with two people lift and carry the unit to it's new location.

-Never push, drag or pull your furniture (especially on carpet)





## PLEASE DO NOT RETURN PRODUCT TO US IMMEDIATELY

If a part is missing or damaged, email our customer service.  
We will gladly ship your replacement parts FREE of charge.

Need Parts or Assistance? Email us : [cs@nbrehome.com](mailto:cs@nbrehome.com)

For Prompt, reliable service, please have your assemble instruction ready

 <b>WARNING</b>	
	<b>Children have died from furniture tipover. To reduce the risk of furniture tipover:</b> <ul style="list-style-type: none"><li>- ALWAYS install Anti-tip device provided.</li><li>- NEVER put a TV on this product.</li><li>- NEVER allow children to stand, climb or hang on any drawers, doors, or shelves.</li><li>- NEVER open more than one drawer at a time.</li><li>- Place heaviest items in the lowest drawers.</li></ul>
	<i>This is a permanent label. Do not remove!</i>

The installation direction should be aligned with the instructions to prevent plate breakage caused by product tipping during installation.

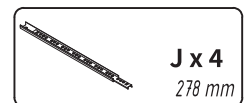
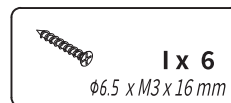
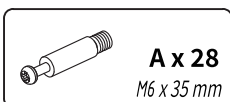
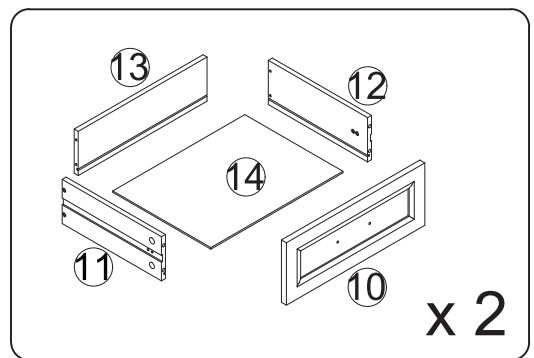
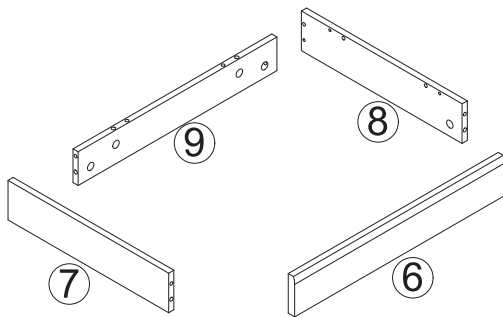
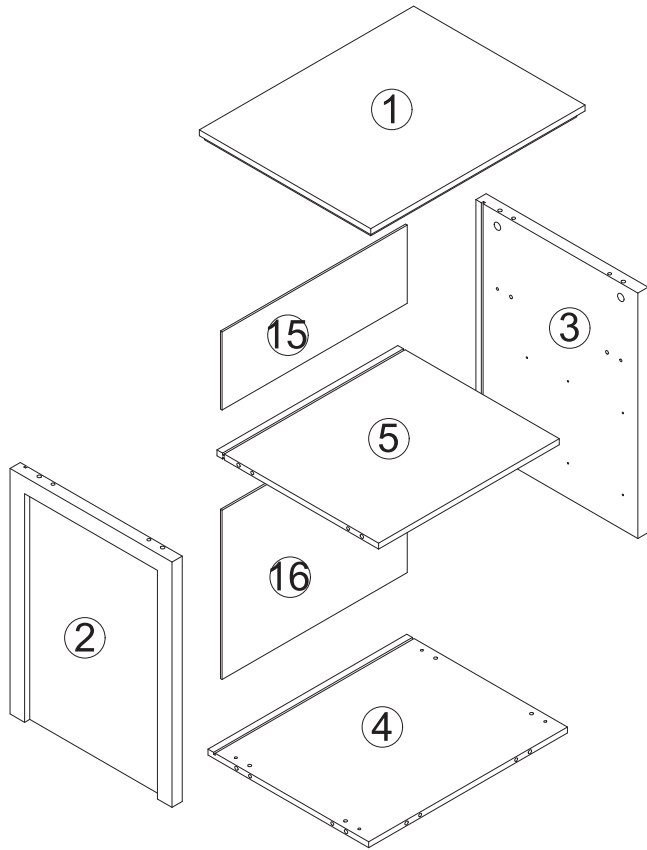

# Step 1

Insert screws (A) into part ② as shown.

Fix the sliding position of the left outer drawer guide rail (J) using screws (E).

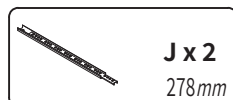
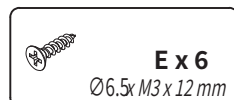
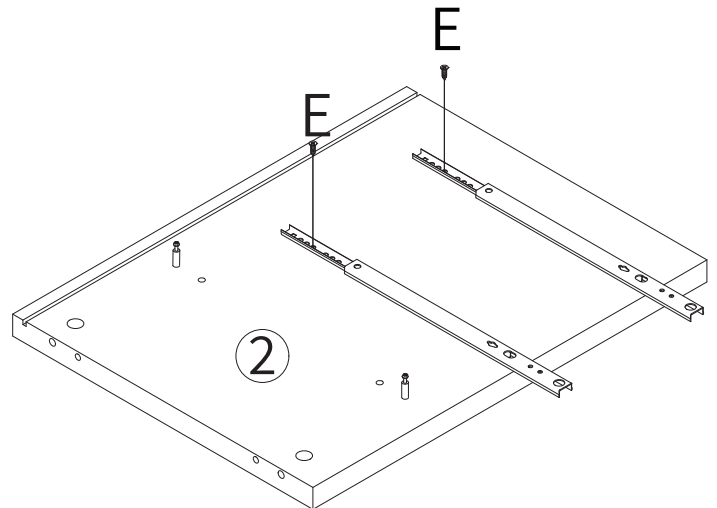
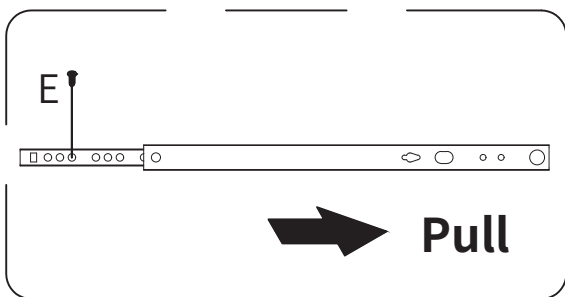
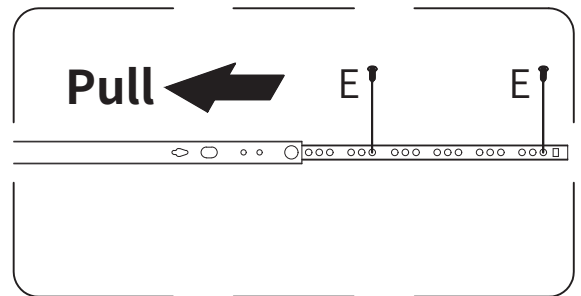
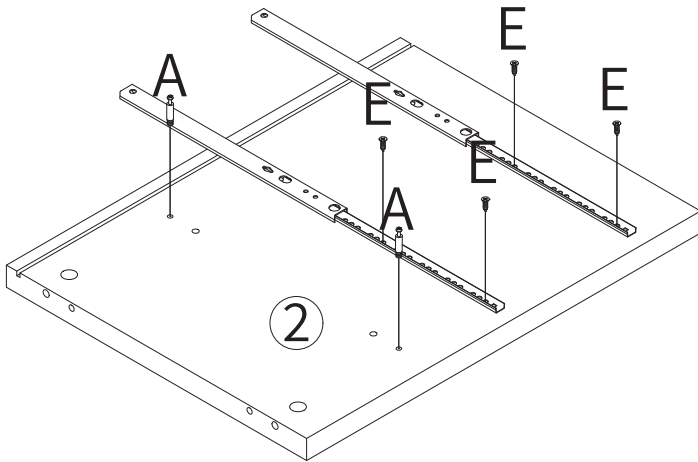

# Step 2

Insert screws (A) into part ③ as shown.  
Fix the sliding position of the right outer drawer guide rail (J) using screws (E).

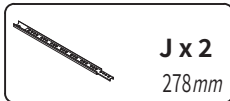
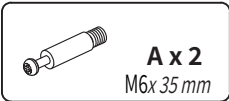
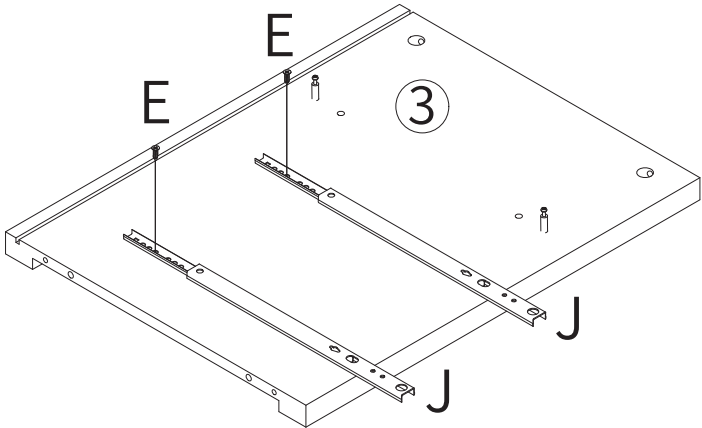
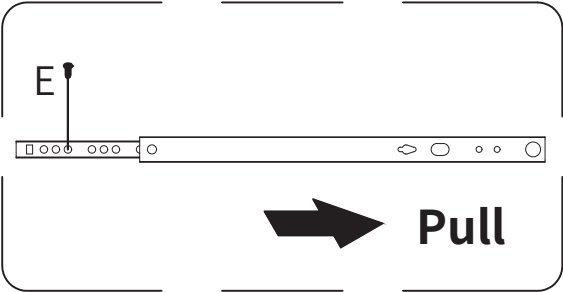
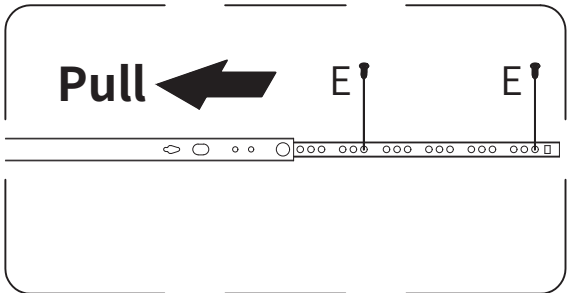
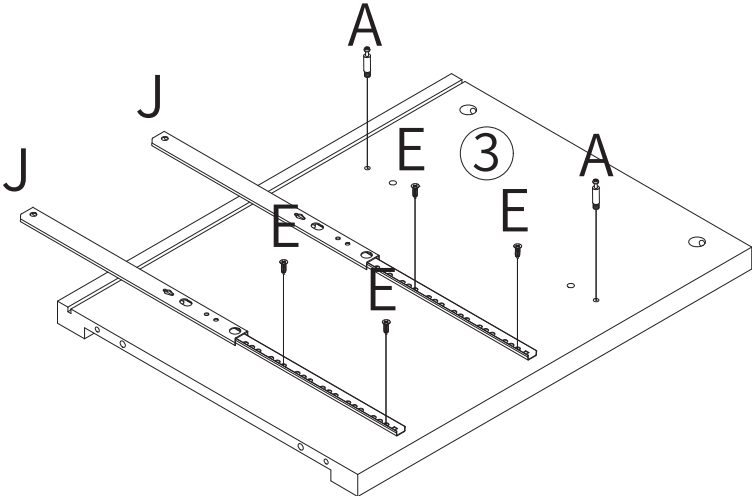

## Step 3

Insert screws (A) into corresponding holes in part ①,⑥as shown.

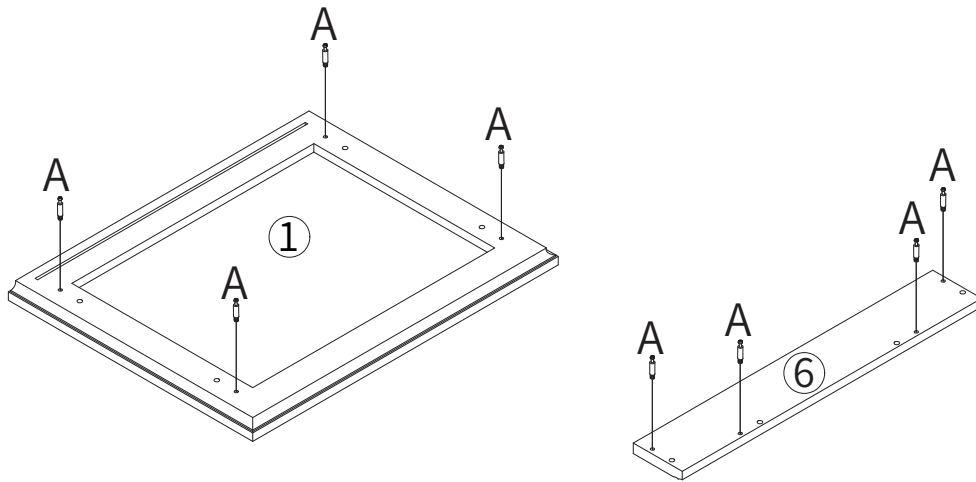

## Step 4

As shown in the figure,insert screws (A) into plates ④,⑦, and⑧.

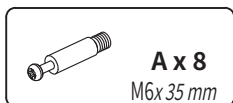
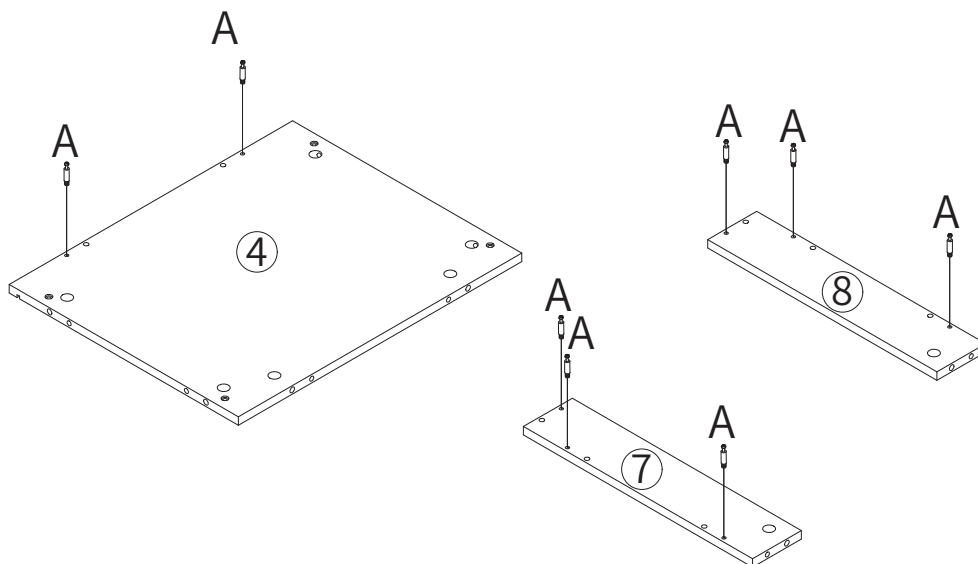

## Step 5

Insert the dowel (C) on part④, then connect part④ and part⑨ with cam lock (B), put the cam lock (B) into the corresponding holes on part⑨ and use a screwdriver to turn it clockwise to tighten, the installation position is as shown.

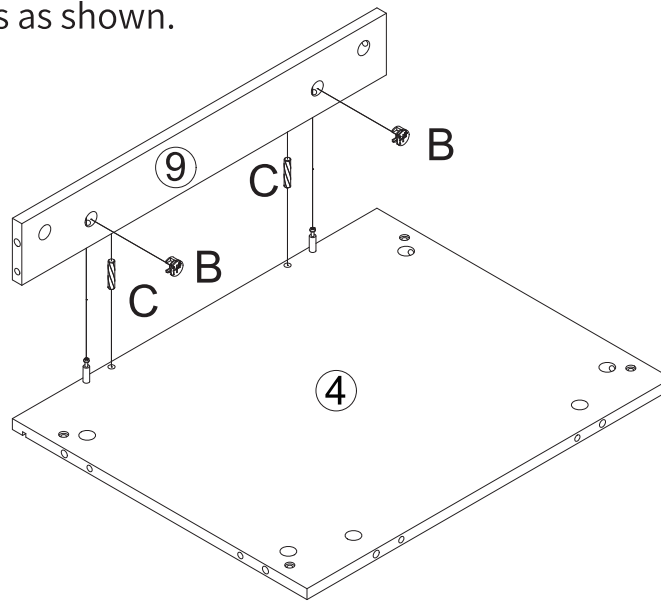
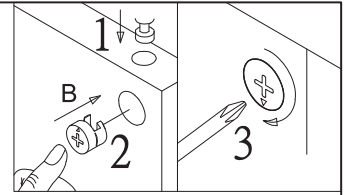

## Step 6

Insert the dowel (C) on part④,⑨. Attach part⑦, ⑧ to assembled unit with eccentric (B). Turn it clockwise to tighten. The installation position is as shown below.

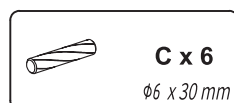
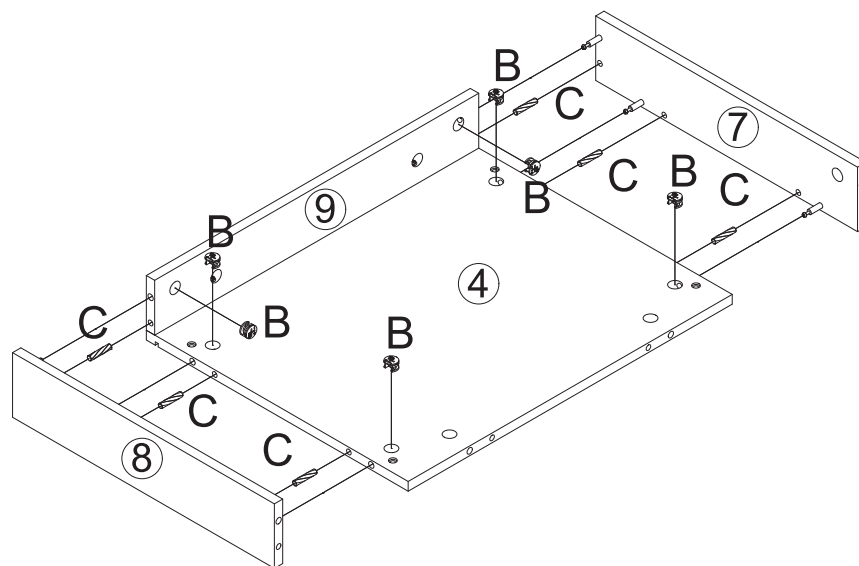
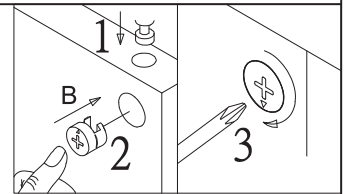

## Step 7

Insert the dowel (C) on part⑥. Attach part⑥ to assembled unit with eccentric (B). Turn it clockwise to tighten. The installation position is as shown below.

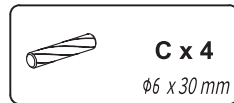
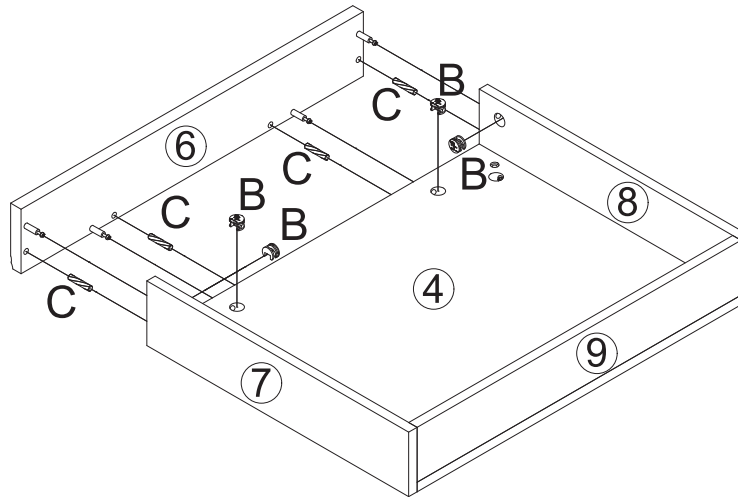
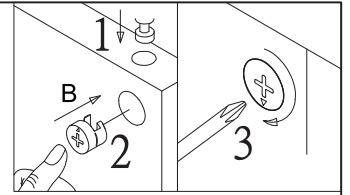

## Step 8

Insert the dowel (C) on part③. Attach part③ to part⑤ with eccentric (B). Turn it clockwise to tighten. The installation position is as shown below.

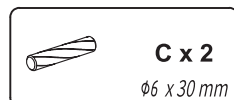
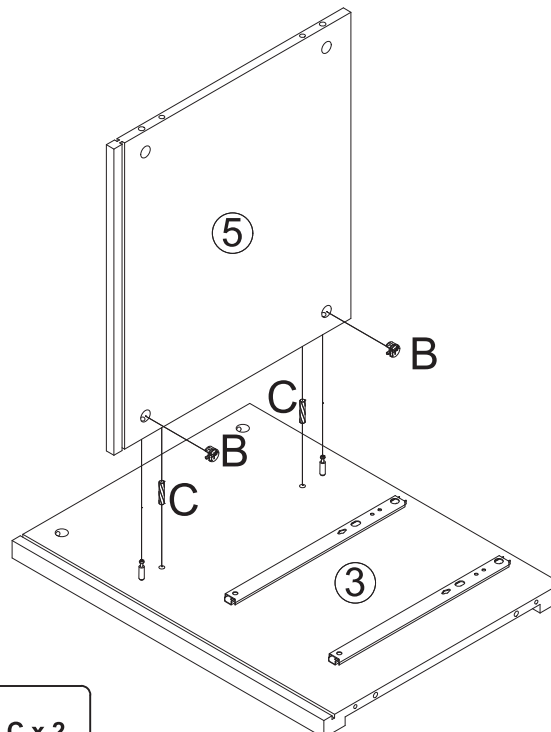
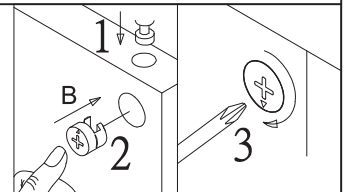

## Step 9

Insert the dowel (C) on part②. Attach part② to part⑤ with eccentric (B). Turn it clockwise to tighten. The installation position is as shown below.

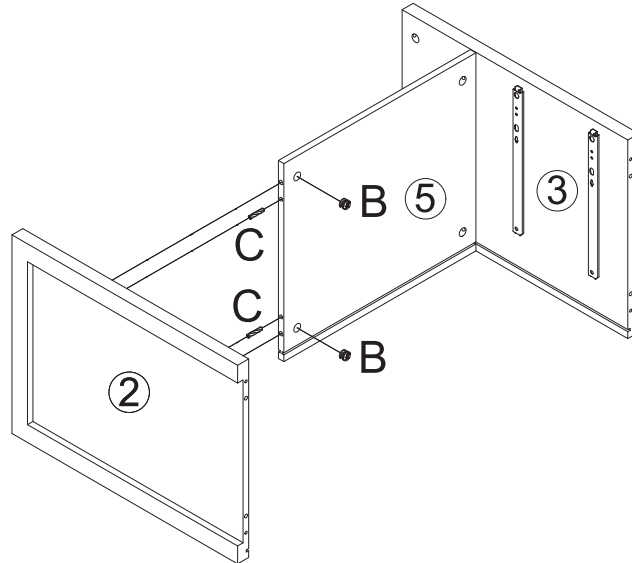
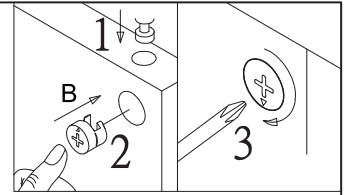

## Step 10

Insert part⑬ along the slot first. Then insert the dowel (C) on part②,③. Assemble part②,③ and part④ with screw (D). The installation position is as shown below.

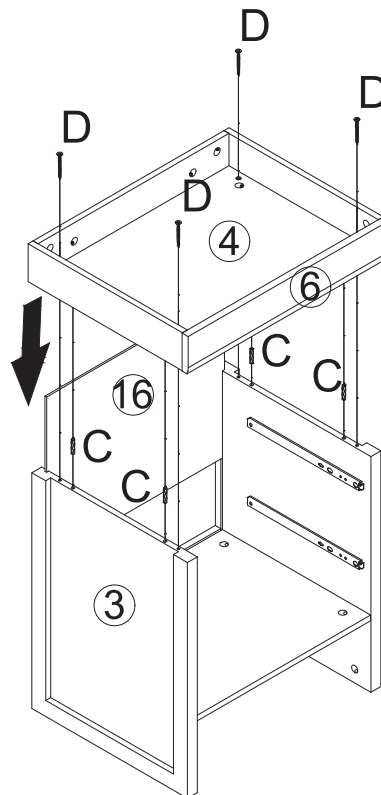

## Step 11

Insert part ⑮ along the slot first. Then insert the dowel (C) on part ②, ③. Attach part ① to assembled unit with eccentric (B). Turn it clockwise to tighten. The installation position is as shown below.

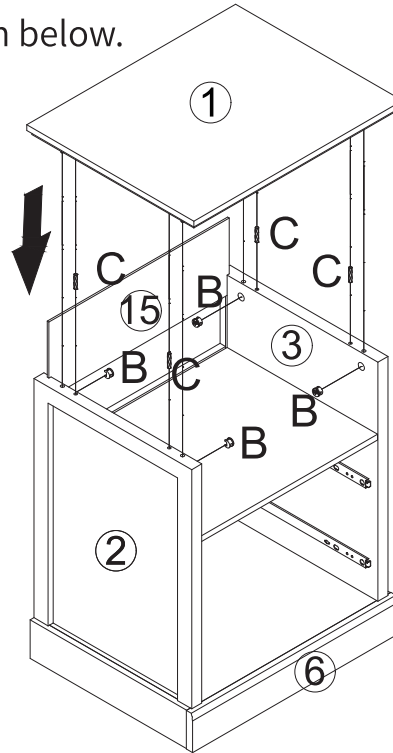
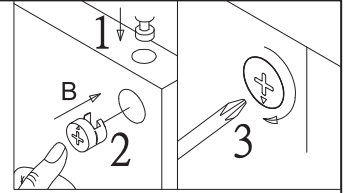

## Step 12

Use the screw (D) to assemble the side panels ⑪, ⑫ and the back panel ⑬. Insert the bottom panel ⑭ according to the slot. Install the screw (A) on the drawer panel ⑩ as shown.

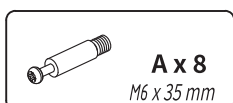
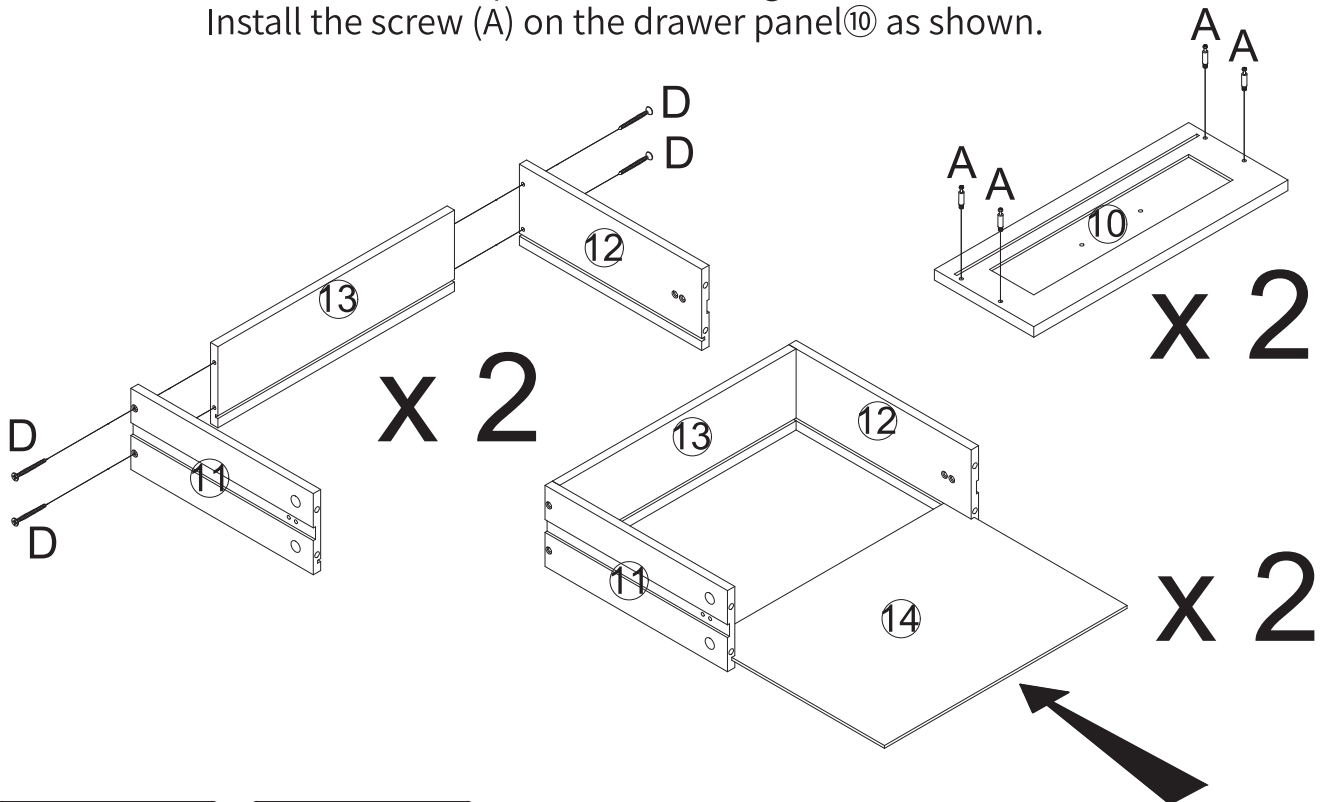

## Step 13

Assemble the drawer panel (10) and the drawer side panels (11, 12) with eccentric (B). Turn it clockwise to tighten. And then use the screw (G) to lock the handle (F) on the drawer panel (10). As shown in the figure.

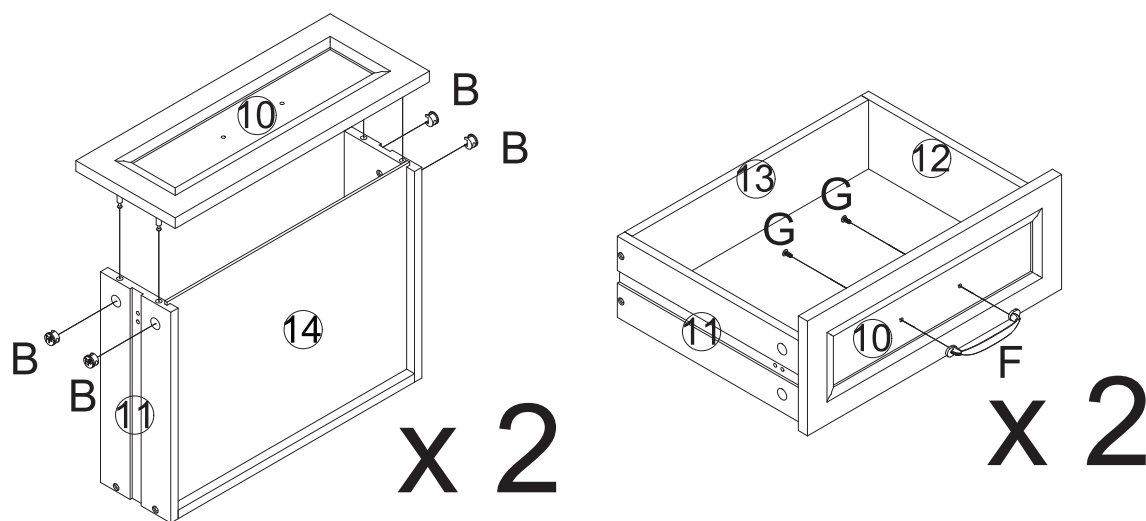
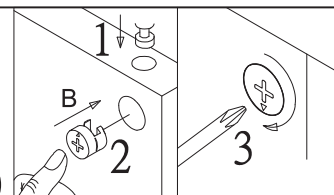

## Step 14

As shown in the figure, slide the slide rail in the direction of the arrow to the farthest position.

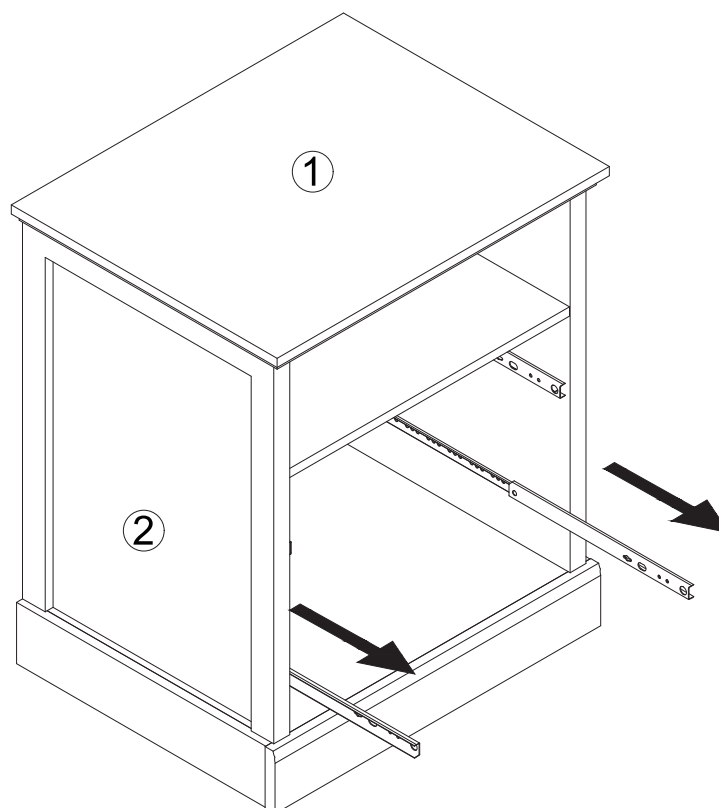

## Step 15

As shown in the picture, after confirming that the sliding rails on both sides are close to the slot at the same time, push the drawer inward.

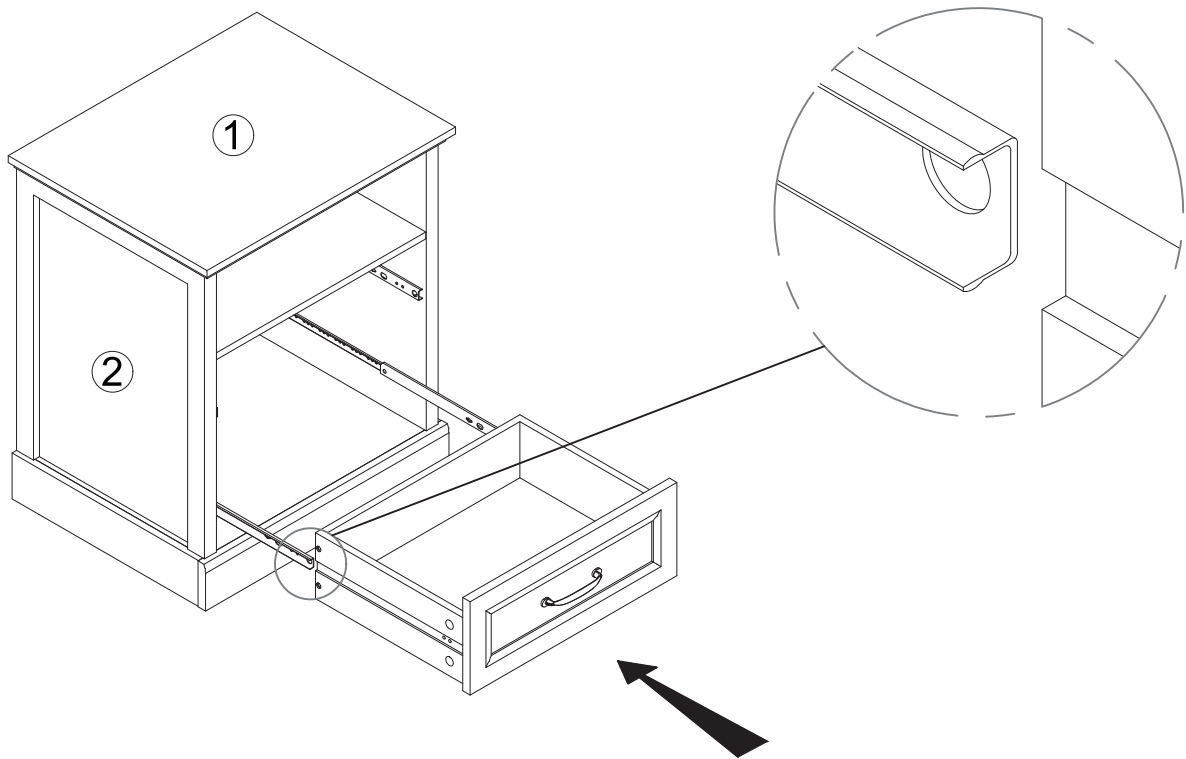

## Step 16

Align the panel holes with the guide rail holes and secure them with screws (G). The installation position is as shown below.

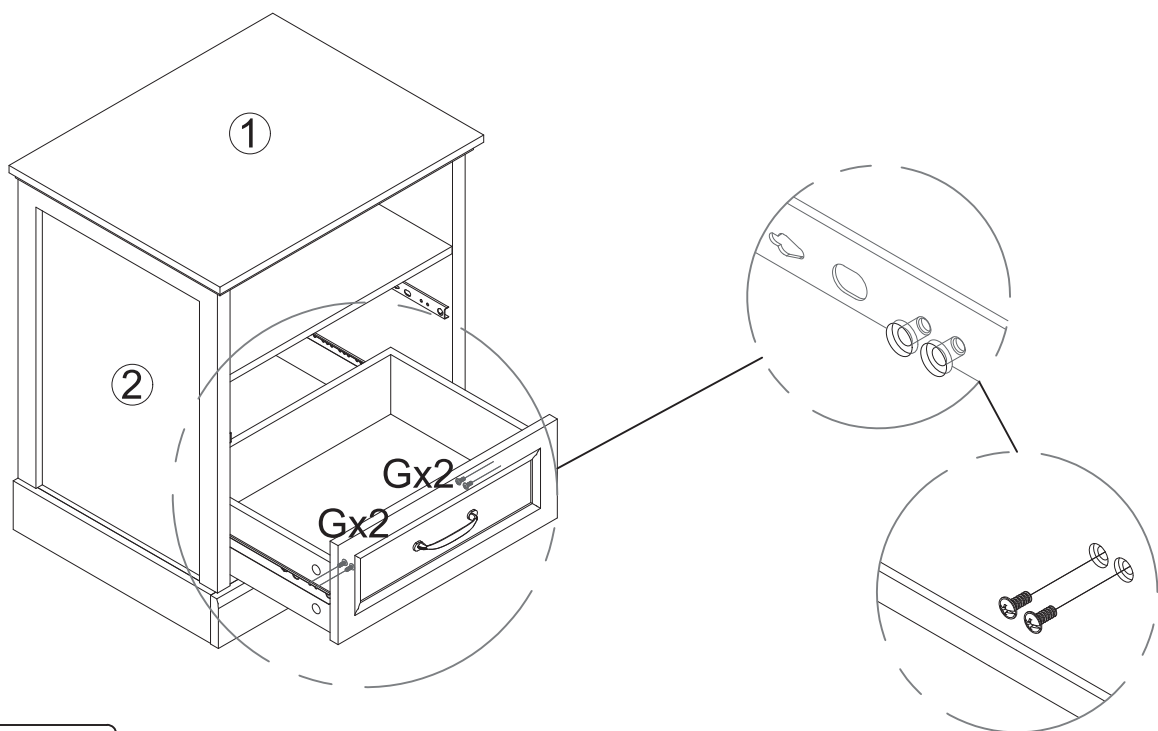

## Step 17

Align the panel holes with the guide rail holes and secure them with screws (G). The installation position is as shown below.

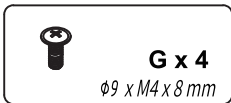
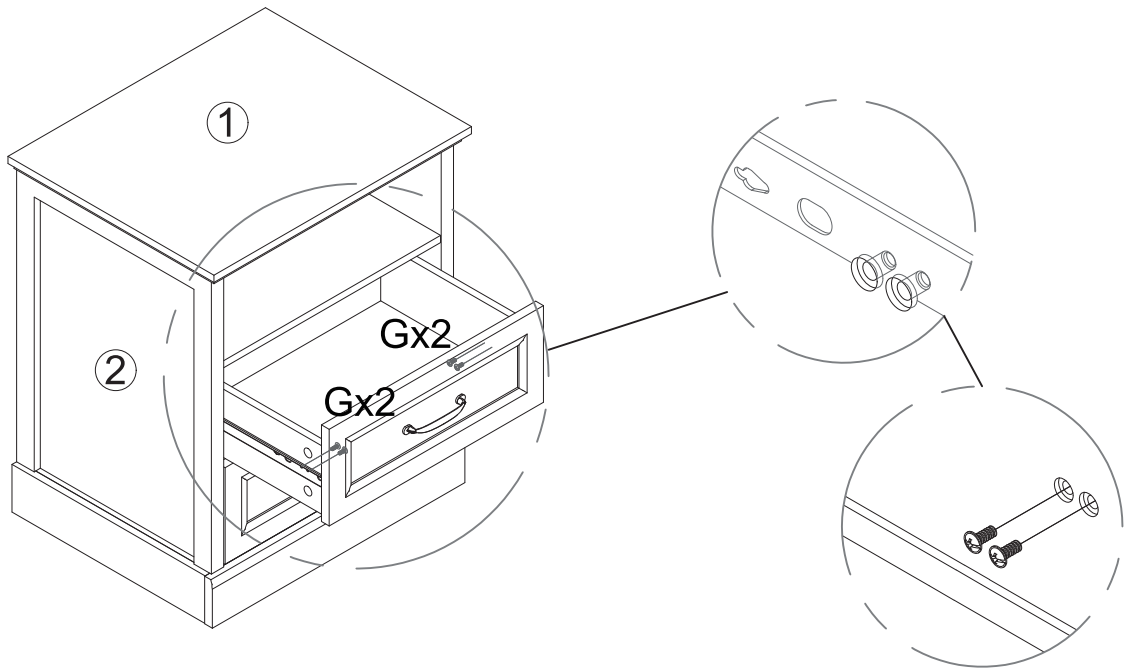

## Step 18

As shown in the figure, use screws (I) to lock the back panel buckle (H) to make the product more stable.

