

Nightstand

Assembly Instructions

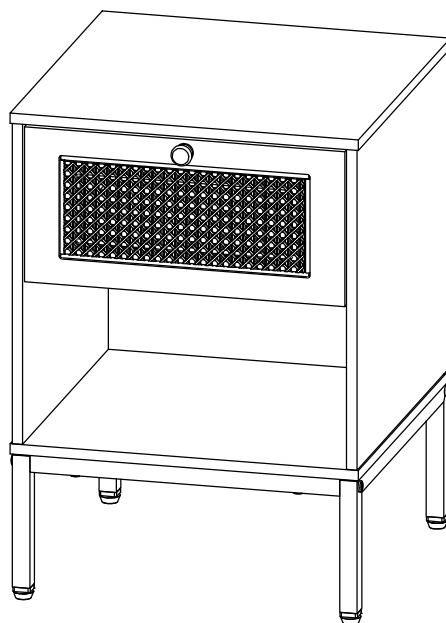

Attention: Please ensure you have all parts before commencing assembly.
Please read all the instructions before commencing.

Have problems when installing or missing parts?

How to find us?





betterasp@hotmail.com

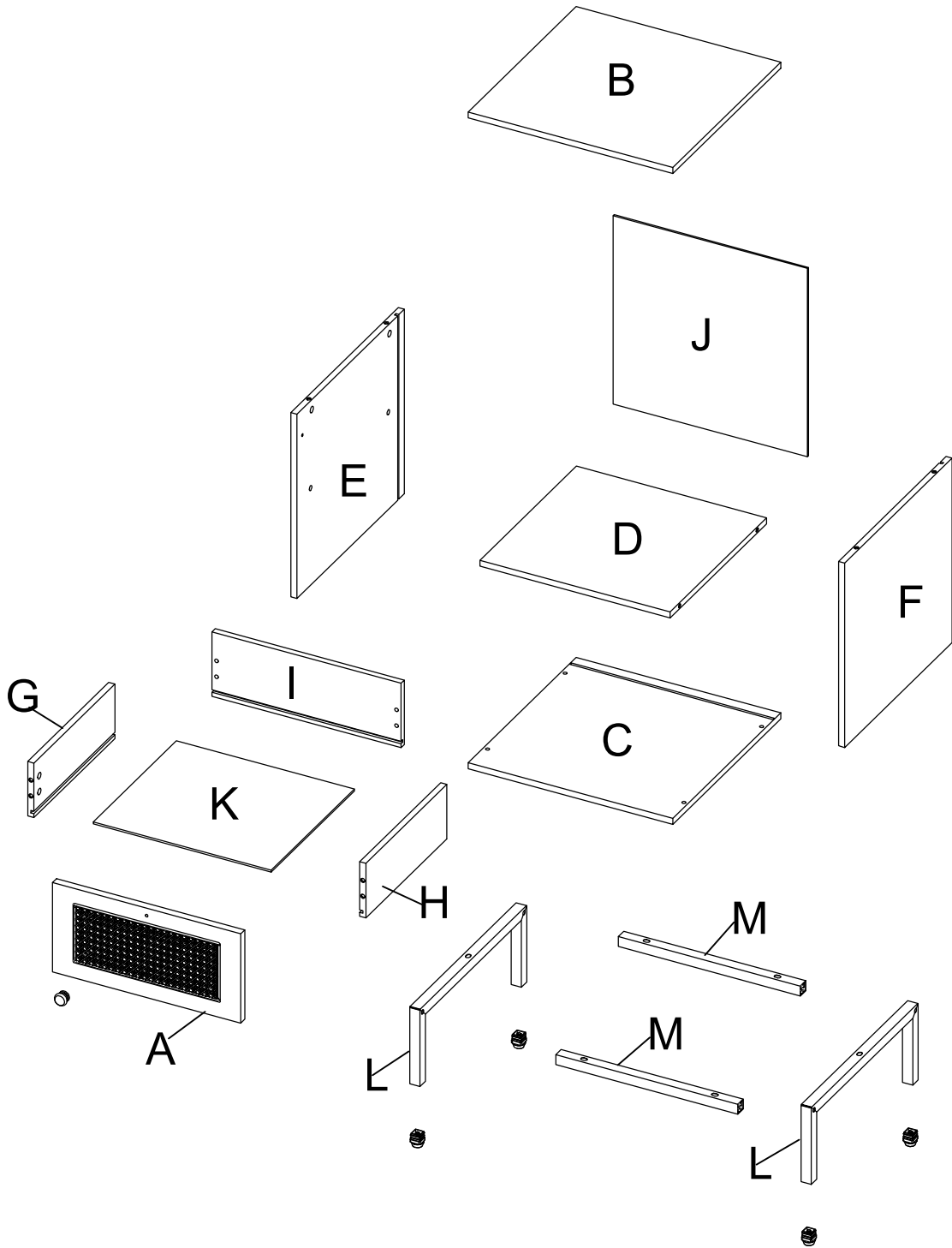



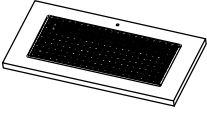
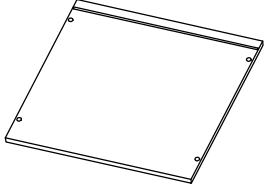
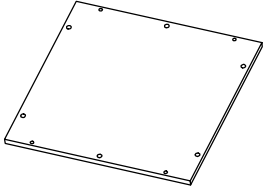
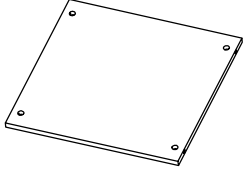
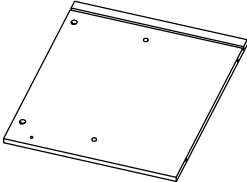
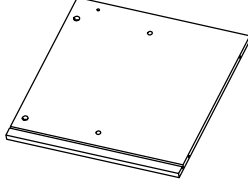
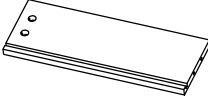
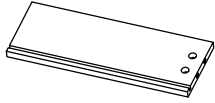
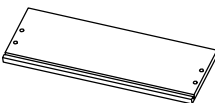
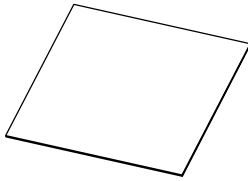
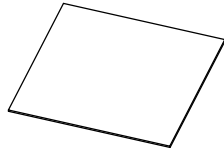
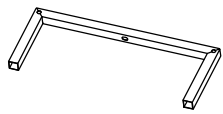



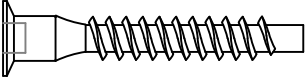

PART LIST

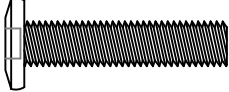

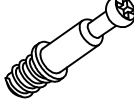
PART LIST

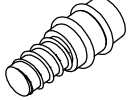
<p>A x 1pc</p> 	<p>B x 1pc</p> 	<p>C x 1pc</p> 	<p>D x 1pc</p> 
<p>E x 1pc</p> 	<p>F x 1pc</p> 	<p>G x 1pc</p> 	<p>H x 1pc</p> 
<p>I x 1pc</p> 	<p>J x 1pc</p> 	<p>K x 1pc</p> 	<p>L x 2pcs</p> 
<p>M x 2pcs</p> 			

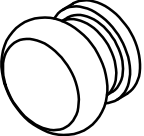
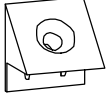
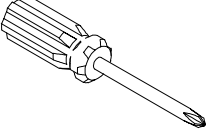
HARDWARE LIST

<p>1</p> 	<p>2</p> 	<p>3</p> 
<p>M6x40 8 pcs</p>	<p>M6x35 4 pcs</p>	<p>M6x27 6 pcs</p>
<p>4</p> 	<p>5</p> 	<p>6</p> 
<p>M4x18 1 pc</p>	<p>M3x12 4 pcs</p>	<p>M6x28 12 pcs</p>
<p>7</p> 	<p>8</p> 	<p>9</p> 
<p>Ø12 12 pcs</p>	<p>M6x19 2 pcs</p>	<p>20x20xM6 4 pcs</p>
<p>10</p> 	<p>11</p> 	<p>12</p> 
<p>1 pc</p>	<p>4 pcs</p>	<p>1 pc</p>
<p>13</p> 		
<p>M4 1 pc</p>		

Please count and verify all parts before assembly .

Using Camlocks

Connect the male camlock as directed in the assembly instructions using a screwdriver.

1 DO NOT OVER TIGHTEN

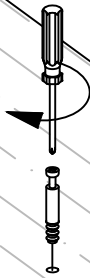

Push the male camlock into the entry hole.

2

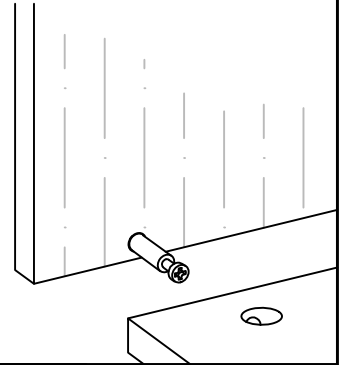

Insert the female camlock as shown in the instruction.

Note: ensure that the arrow on the top of the camlock points towards the entry hole for the male camlock.

3

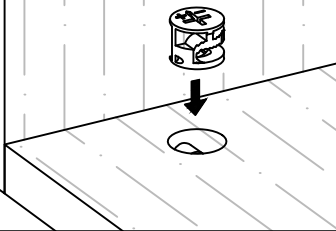

Turn the female camlock clockwise with a screwdriver. You should feel a click when the camlock is locked in place.

The joint is now secure.

4

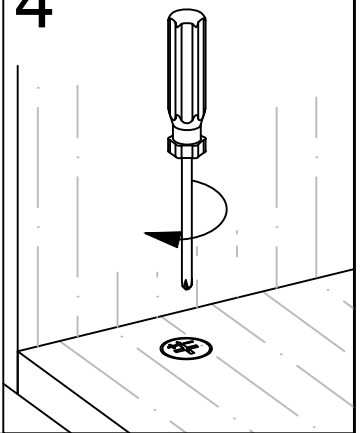

STEP 1

9  x4

Please use a hammer or solid tools
(not included) to knock the footpads
into the frame.

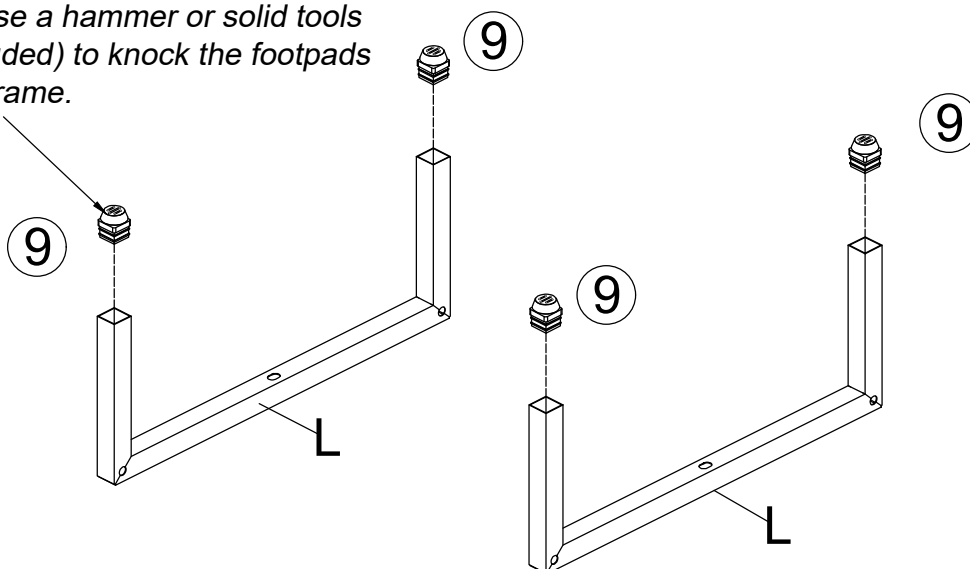

STEP 2

6  x8

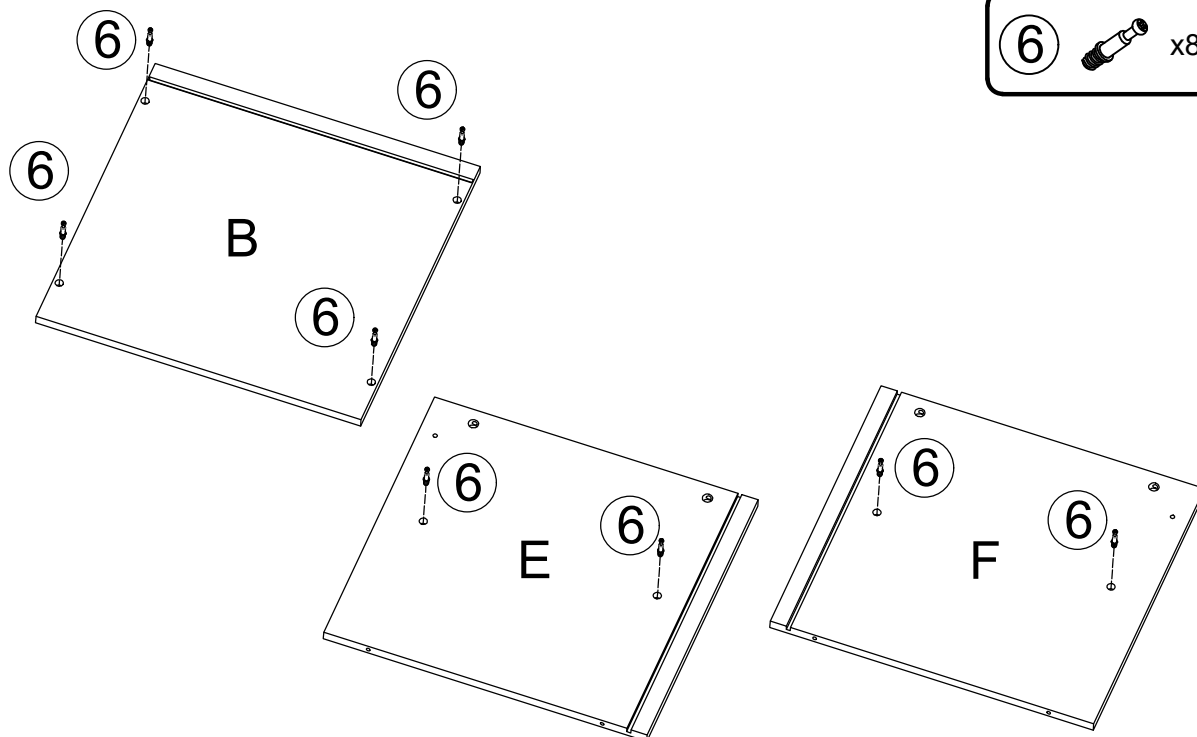

STEP 3

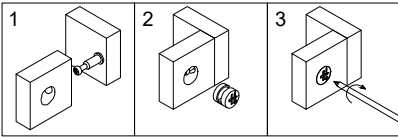
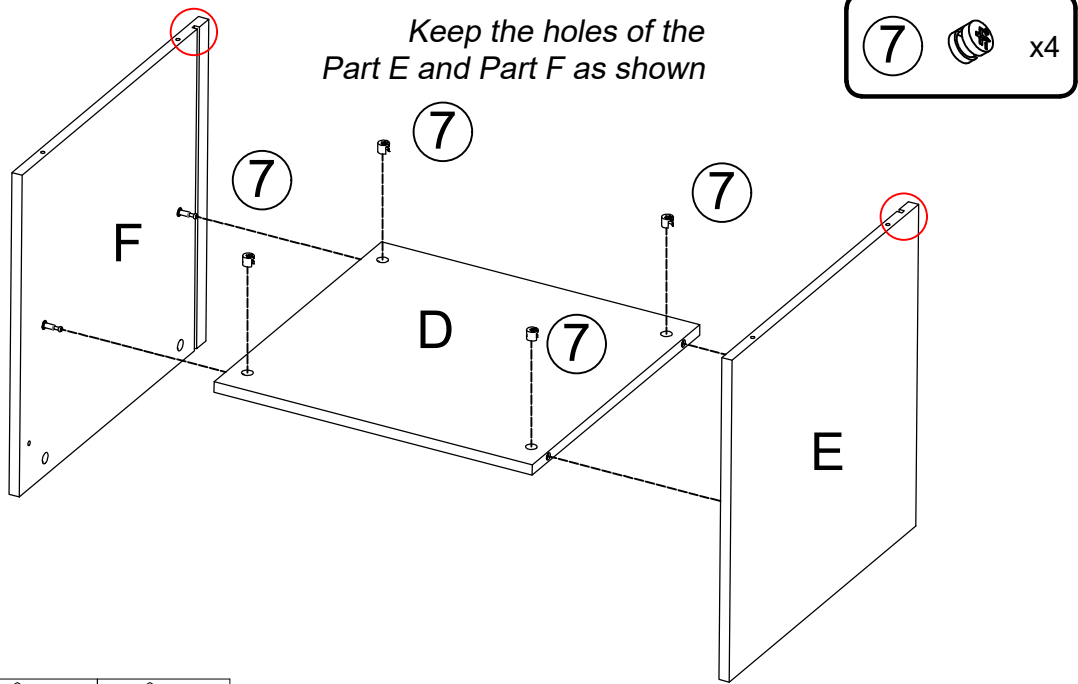

Please point the arrow upward to the mounting hole when installing Part 7 then use screwdriver to tighten it in the "+" direction.

Cam Lock Fastening System

STEP 4

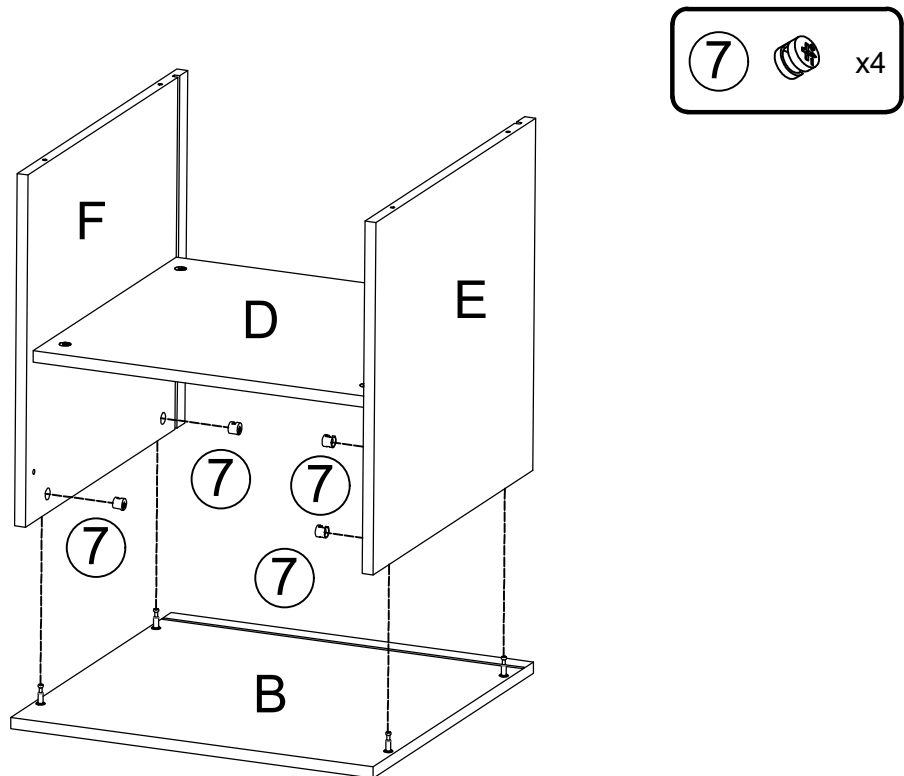

STEP 5

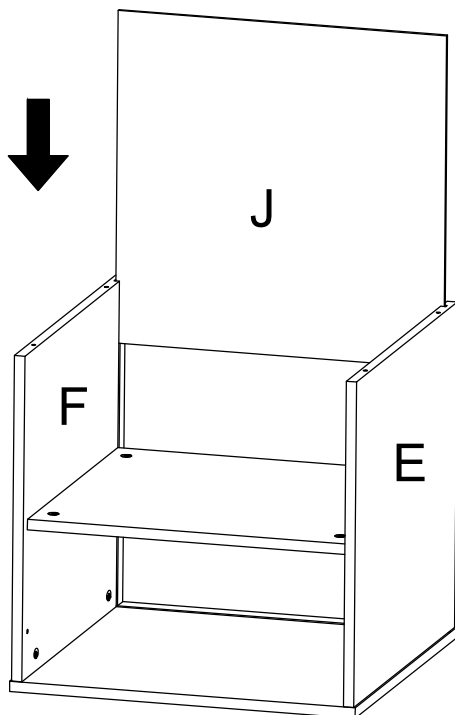

STEP 6

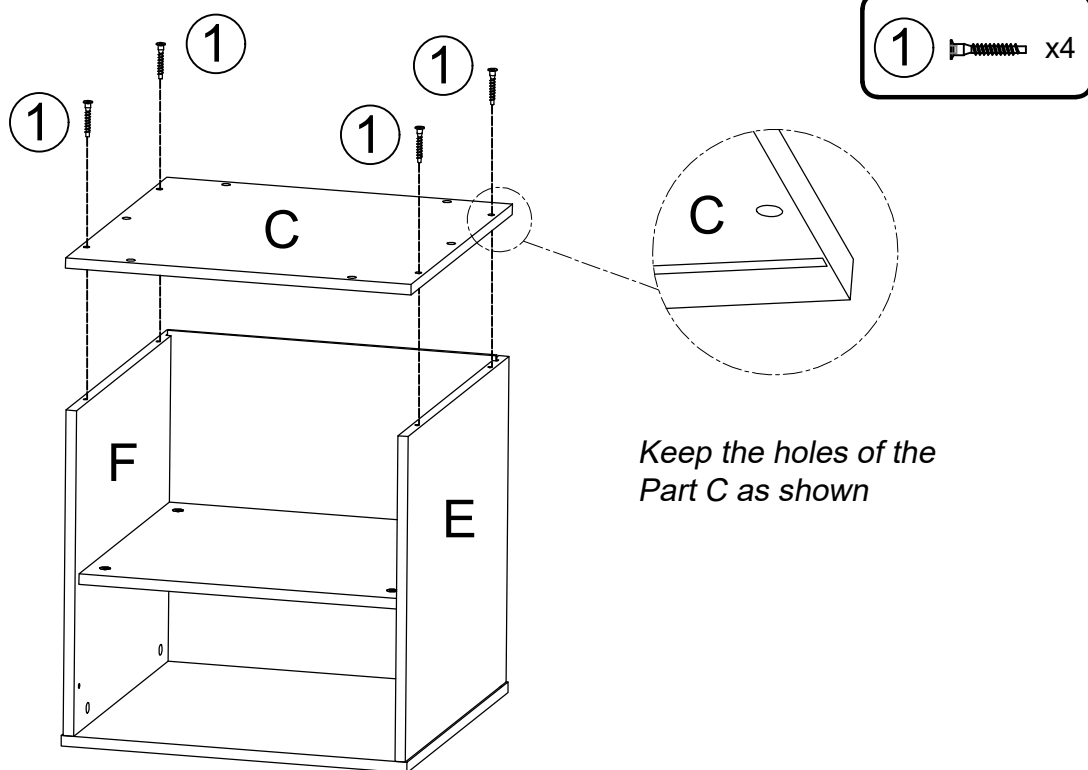

STEP 7

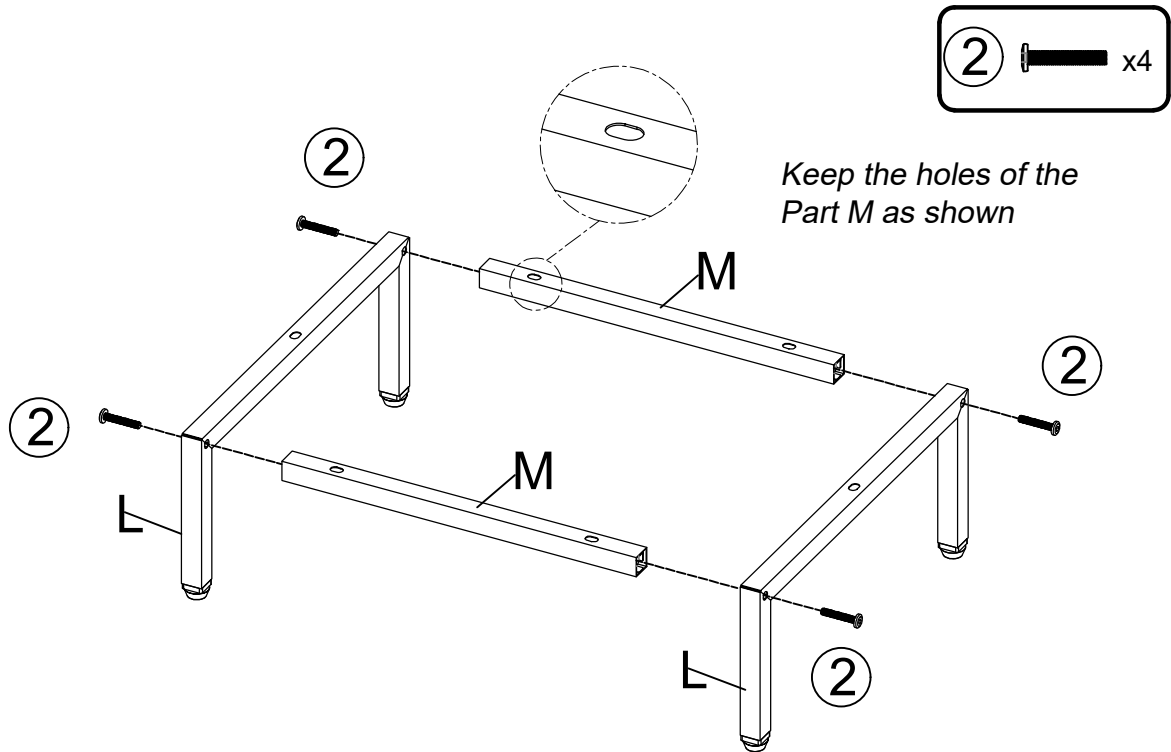

STEP 8

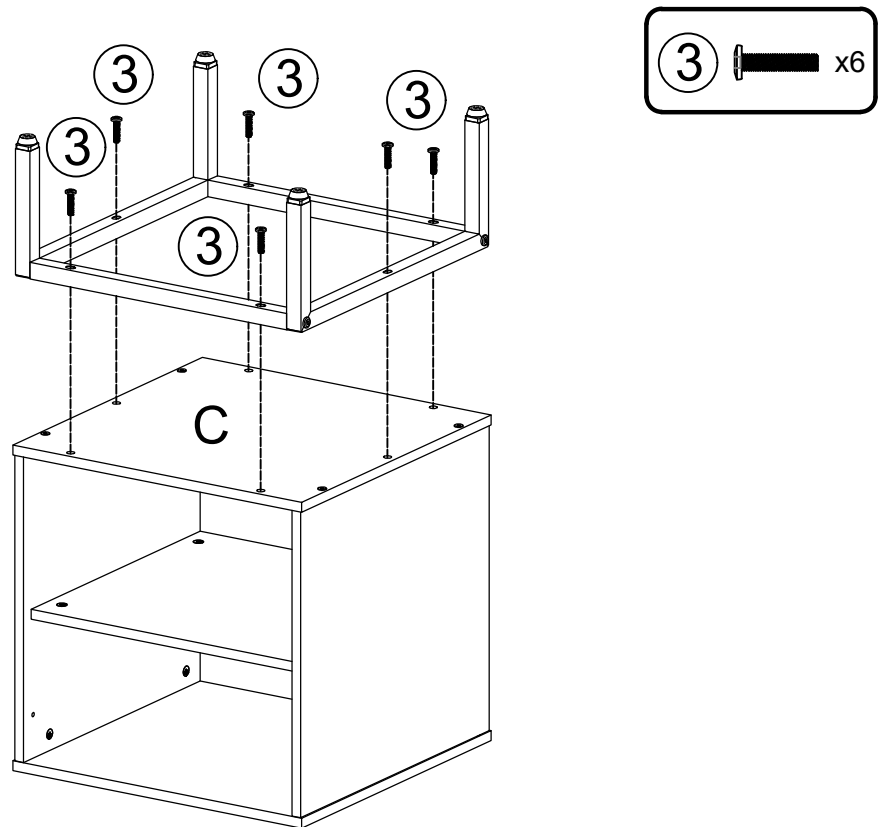

STEP 9

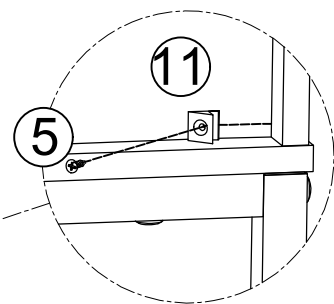
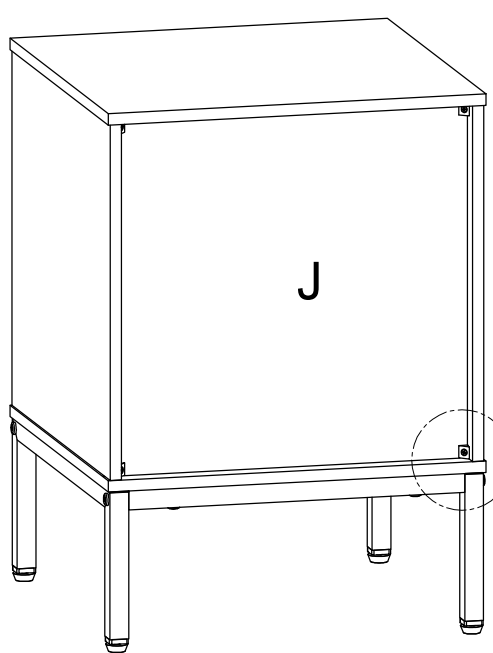
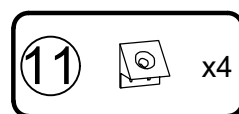
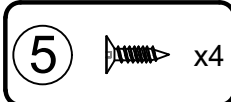

STEP 10

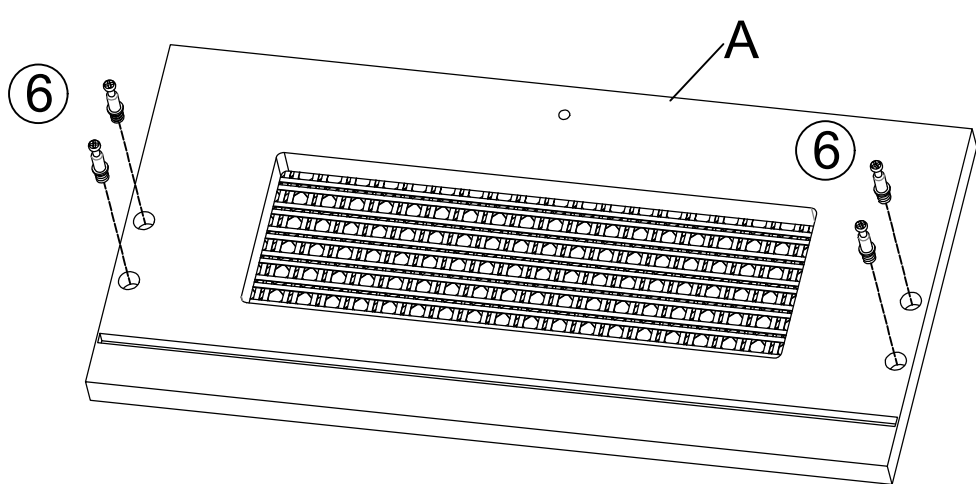
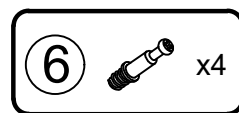

STEP 11

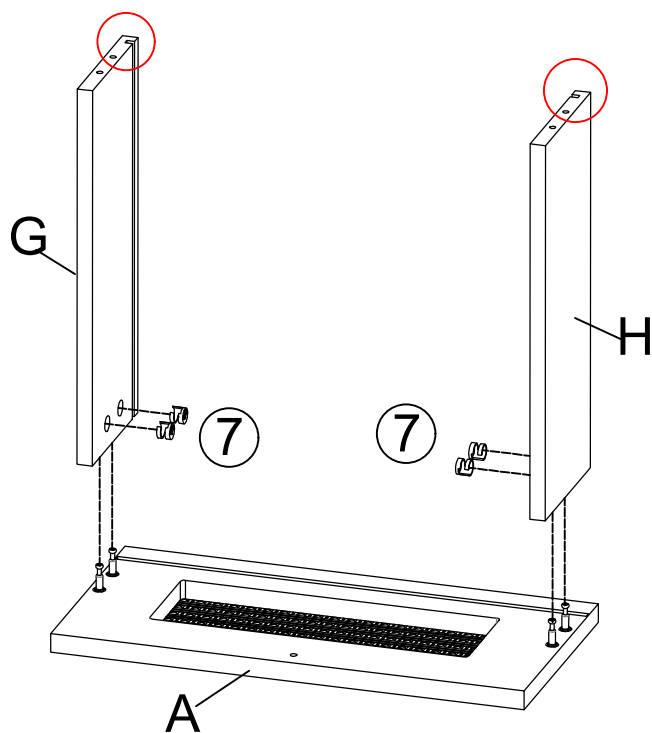
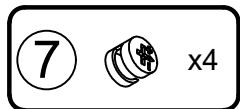

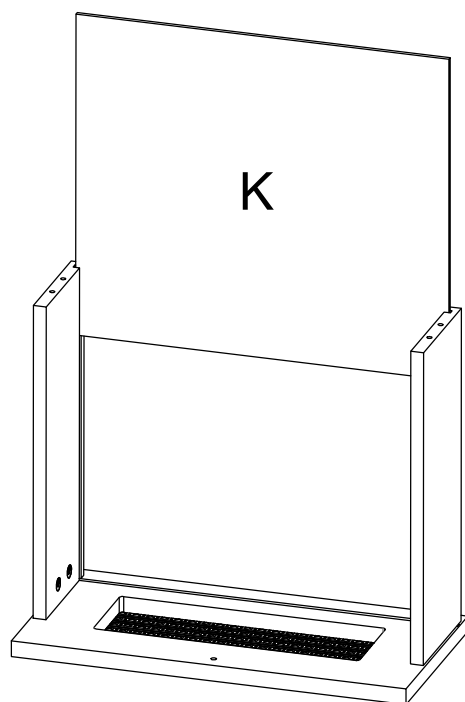

Keep the holes of the
Part G and Part H as shown

STEP 12



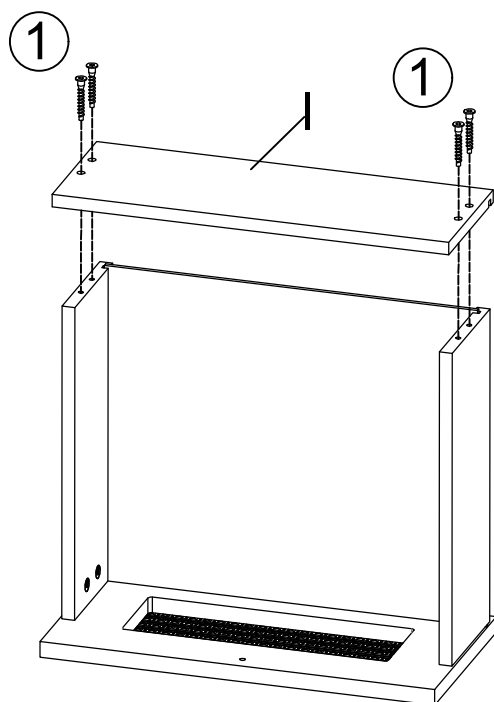

STEP 13

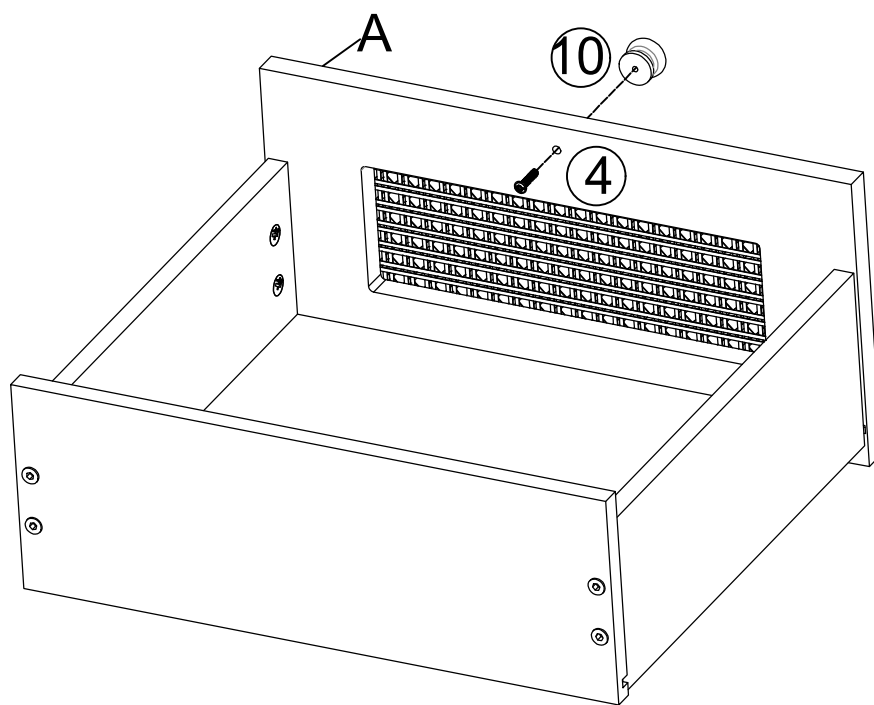

1  x4

STEP 14



4  x1

10  x1

STEP 15

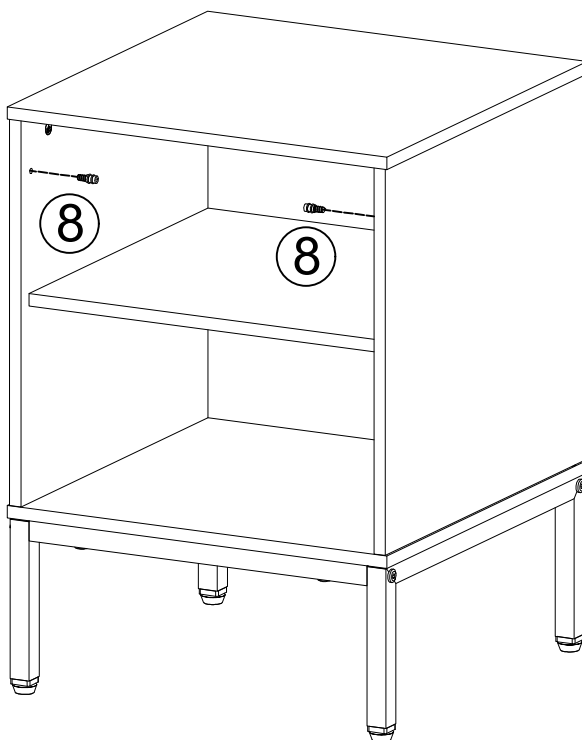
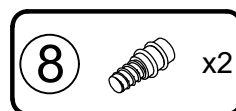

STEP 16

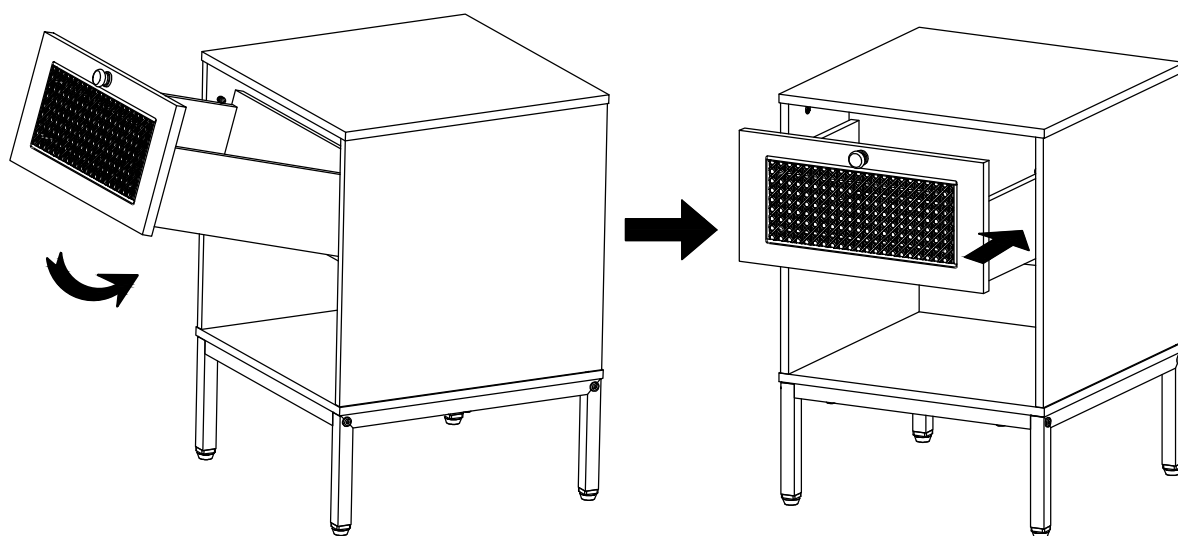

STEP 17

