

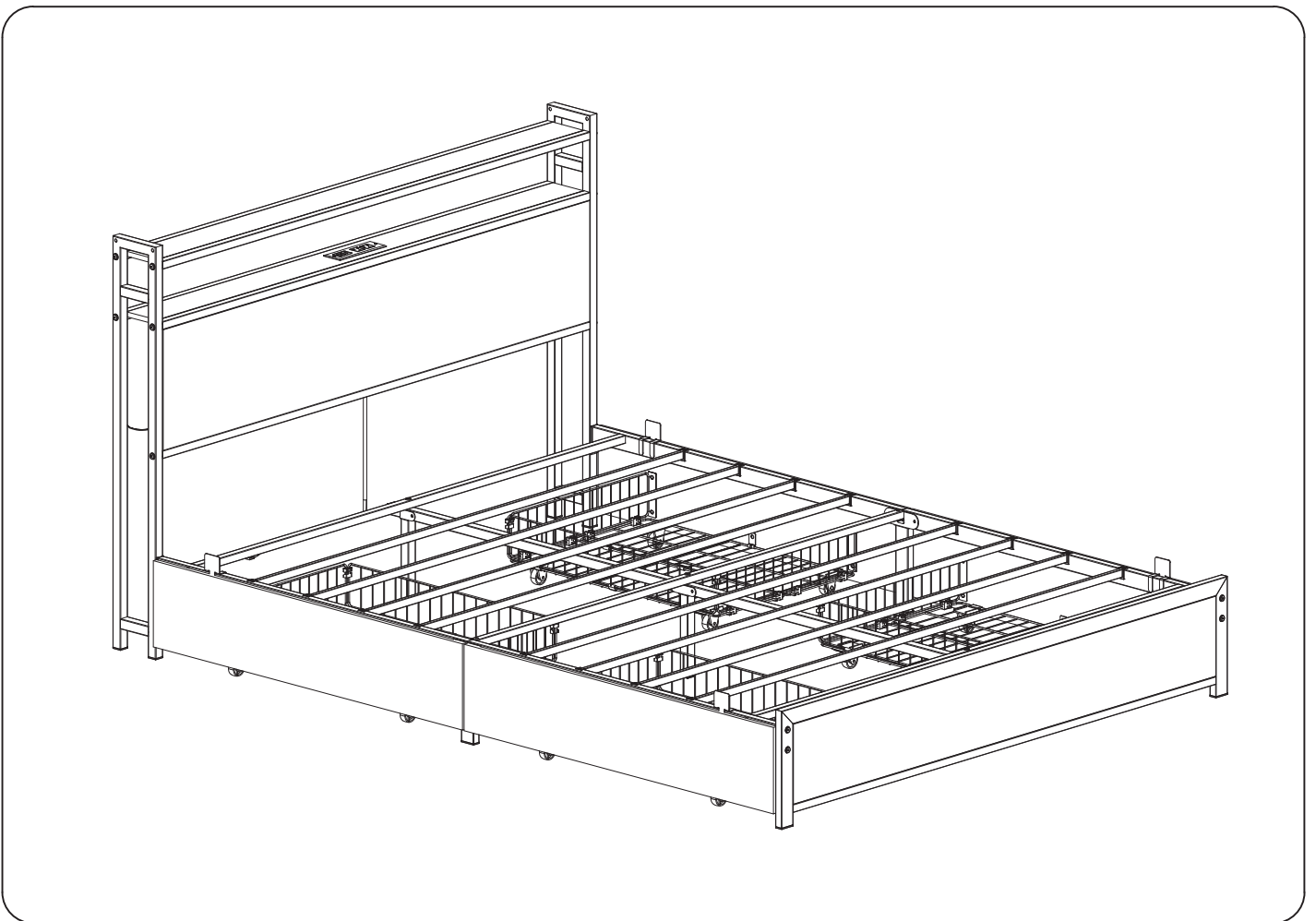

## Platform Bed with Storage Headboard and Drawers



Thank you for your purchase.

Please contact us if you have difficulty with assembly or need replacement parts

**Customer Service is here to assist you.**

Please attach your User Name or Order ID so that we can assist you better

# Introduction

## Guide of Manual

- Please read the following instruction carefully and use the product properly.
- Please keep this manual and hand it over when you transfer the product.
- Please contact us when further information and help needed.

## Notes



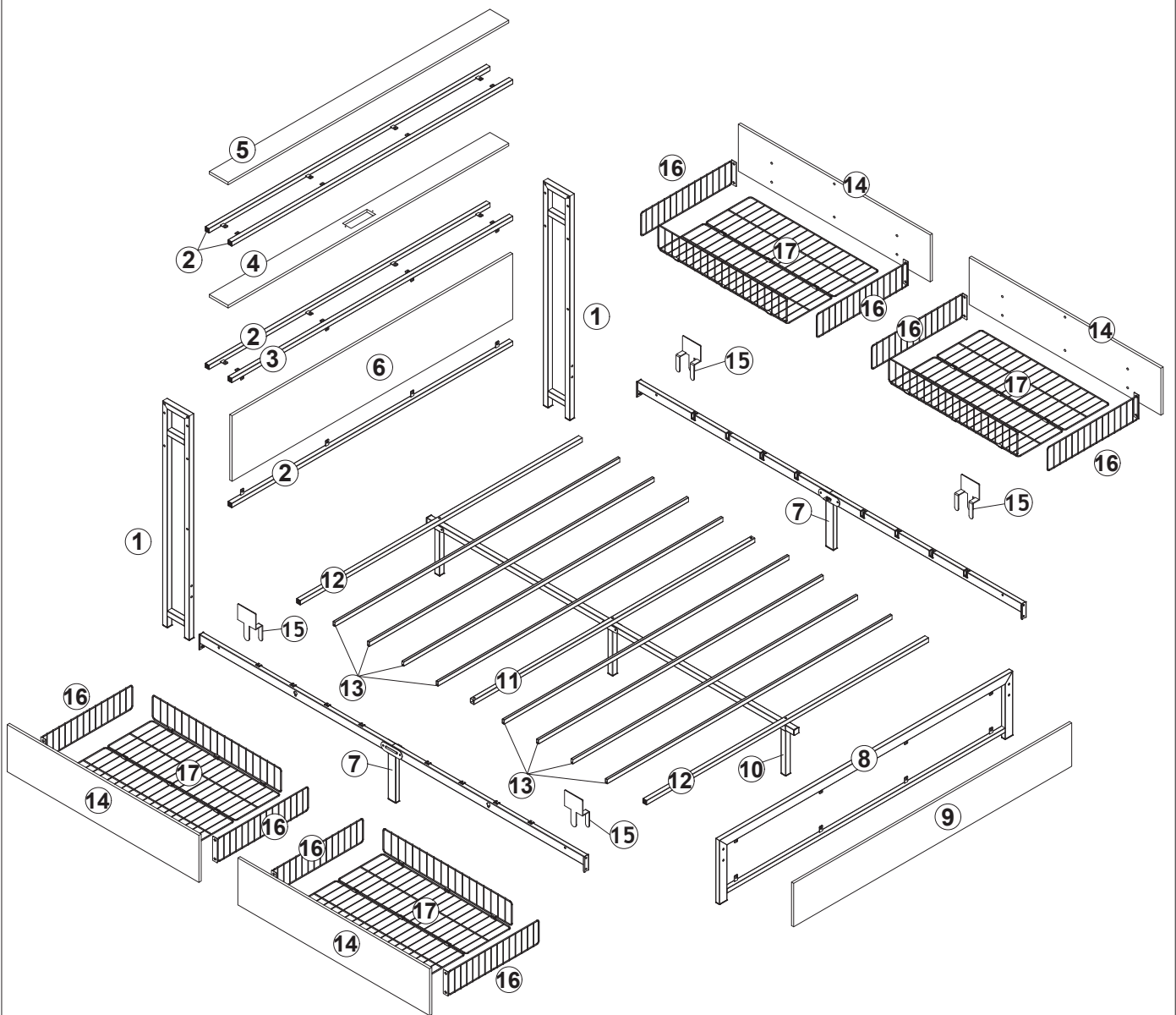

- Make sure to start on the correct instruction page for the bed configuration you are assembling.
- Unpack parts and hardware carefully to prevent scratching of lacquered components.
- Please assemble the product according to the steps on the diagram strictly.
- Do not fully tighten the screws until all pieces are situated in place.
- For continued use, it's suggested you regularly check the tightness of bolts and connections to ensure safety.
- Do not assemble and disassemble the product repeatedly to avoid damaged.
- To avoid confusion keep all parts and hardware together with the boxes that they came in; some bed configurations require multiple boxes.

# Part List 1



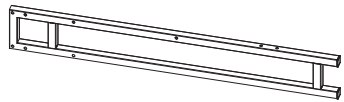

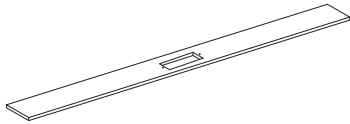
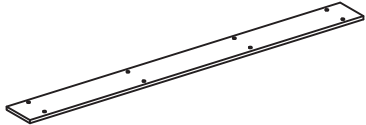
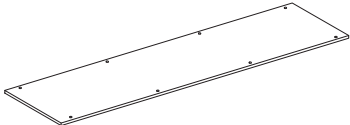

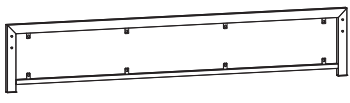
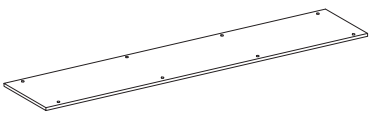
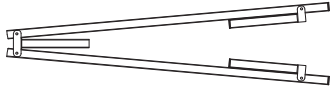
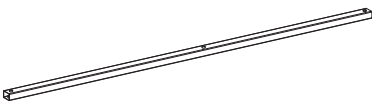
# Part List 1



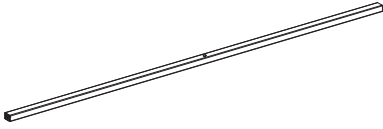
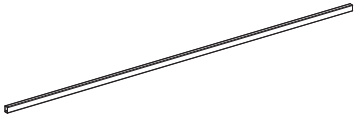
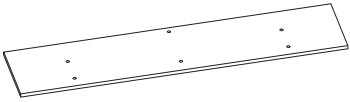
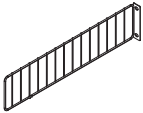
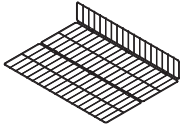
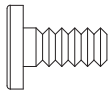
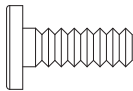
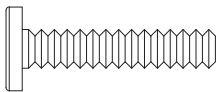
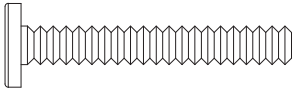

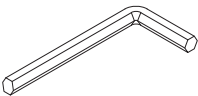

## COMPONENTS

NO.	DESCRIPTION		DIMENSION	QTY
1	HD Side Frame		1020x140x25	2pcs
2	HD Upper & Back Tube		(1890.1480.1330) x45x20	4pcs
3	HD Middle Front Tube		(1890.1480.1330) x45x20	1pc
4	HD Middle Panel		(1888.1478.1328) x99x12	1pc
5	HD Top Panel		(1888.1478.1328) x99x12	1pc
6	HD Middle Front Panel		(1888.1478.1328) x299x12	1pc
7	Side Rail		(2030.1912) x250.5x42.9	2pcs
8	Foot-board Frame		(1955.1545.1395) x290x20	1pc
9	Foot-board Panel		(1874.1464.1314) x198x12	1pc
10	Center Brace		(1932.1812) x229.5x30	1pc
11	Center Cross Beam		(1890.1479.1329) x20x20	1pc

# COMPONENTS

NO.	DESCRIPTION		DIMENSION	QTY
12	Slat with nut		(1895.1485.1335) x20x20	2pcs
13	Bed Slat		(1910.1500.1350) x20x10	8pcs
14	Drawer Front Panel		( 950.1010 ) x214x12	4pcs
15	Mattress Stopper			4pcs
16	Drawer Side Frame			8pcs
17	Drawer Bottom Frame			4pcs
A	Screw		M6x12	52pcs
B	Screw		M6x16	4pcs
C	Screw		M6x40	24pcs
D	Screw		M6x55	3pcs
E	Washer		M13x8x1	18pcs
F	Allen Wrench		S4	1pc
G	EVA Foam		800x14x2	2pcs

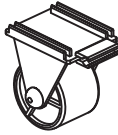
# COMPONENTS

NO.	DESCRIPTION		DIMENSION	QTY
<b>H</b>	Charging Socket		<b>USB</b>	<b>1pc</b>
<b>I</b>	Screw		<b>M3x10</b>	<b>2pcs</b>
<b>J</b>	LED Strip Light		<b>(1880.1470.1320) x8x2</b>	<b>1pc</b>
<b>K</b>	EVA Foam		<b>(1880.1470.1320) x10x2</b>	<b>1pc</b>
<b>L</b>	Drawer Wheel			<b>16pcs</b>
<b>M</b>	Drawer Clip			<b>40pcs</b>
<b>N</b>	Drawer Clip			<b>4pcs</b>

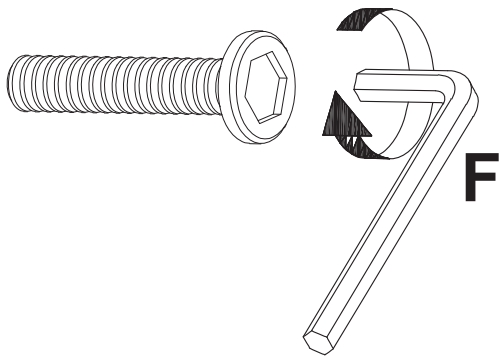

The usage method of the wrench is as shown in the figure.

# Assembly Steps

## STEP 1

Fix HD top panel (5) to tubes (2) with screw (A).

Fix HD middle panel (4) to tubes (2), (3) with screw (A).

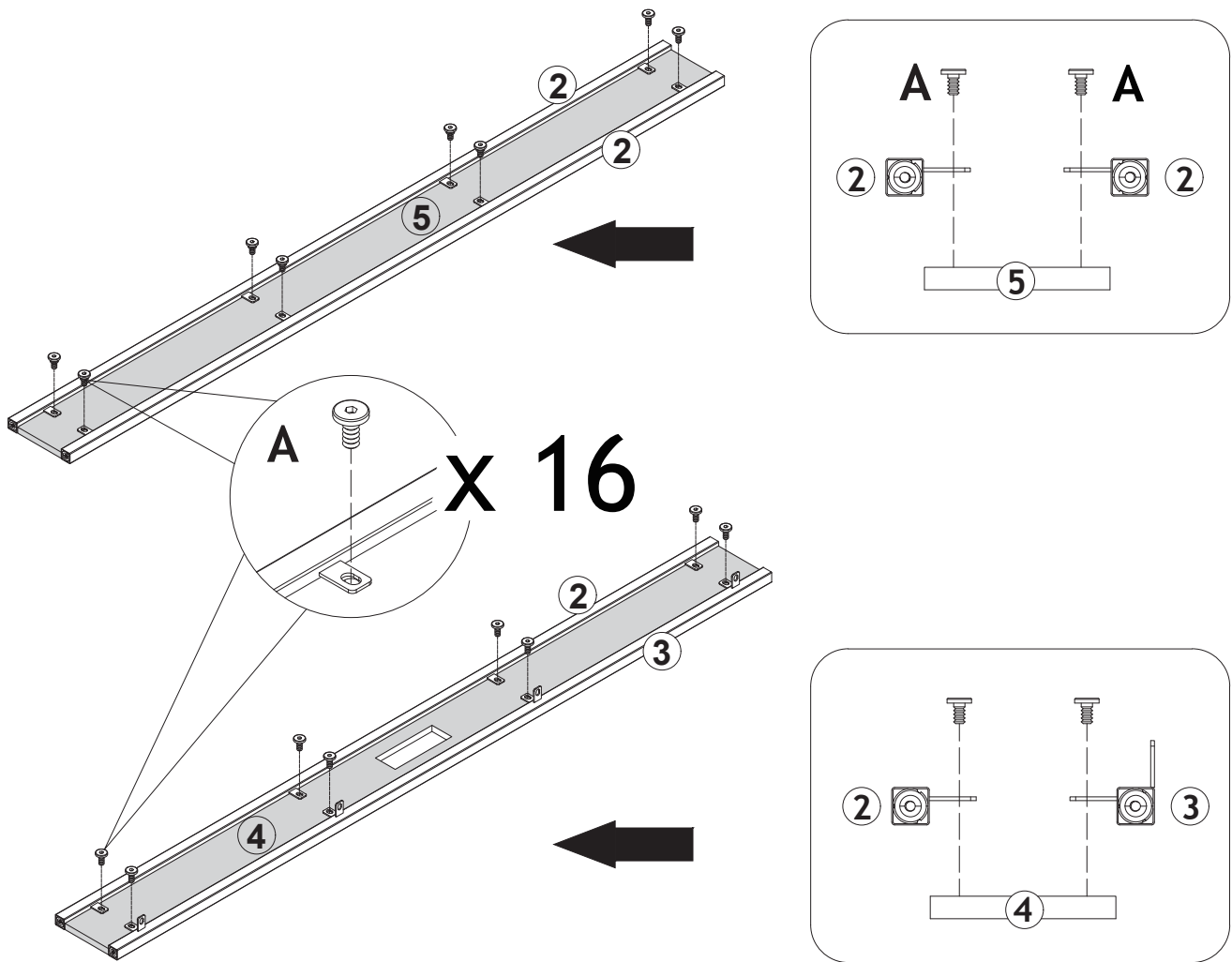

Install as shown in the figure.

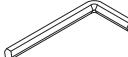
CODE	HARDWARE	QTY
A	 M6x12	16
F	 S4	1



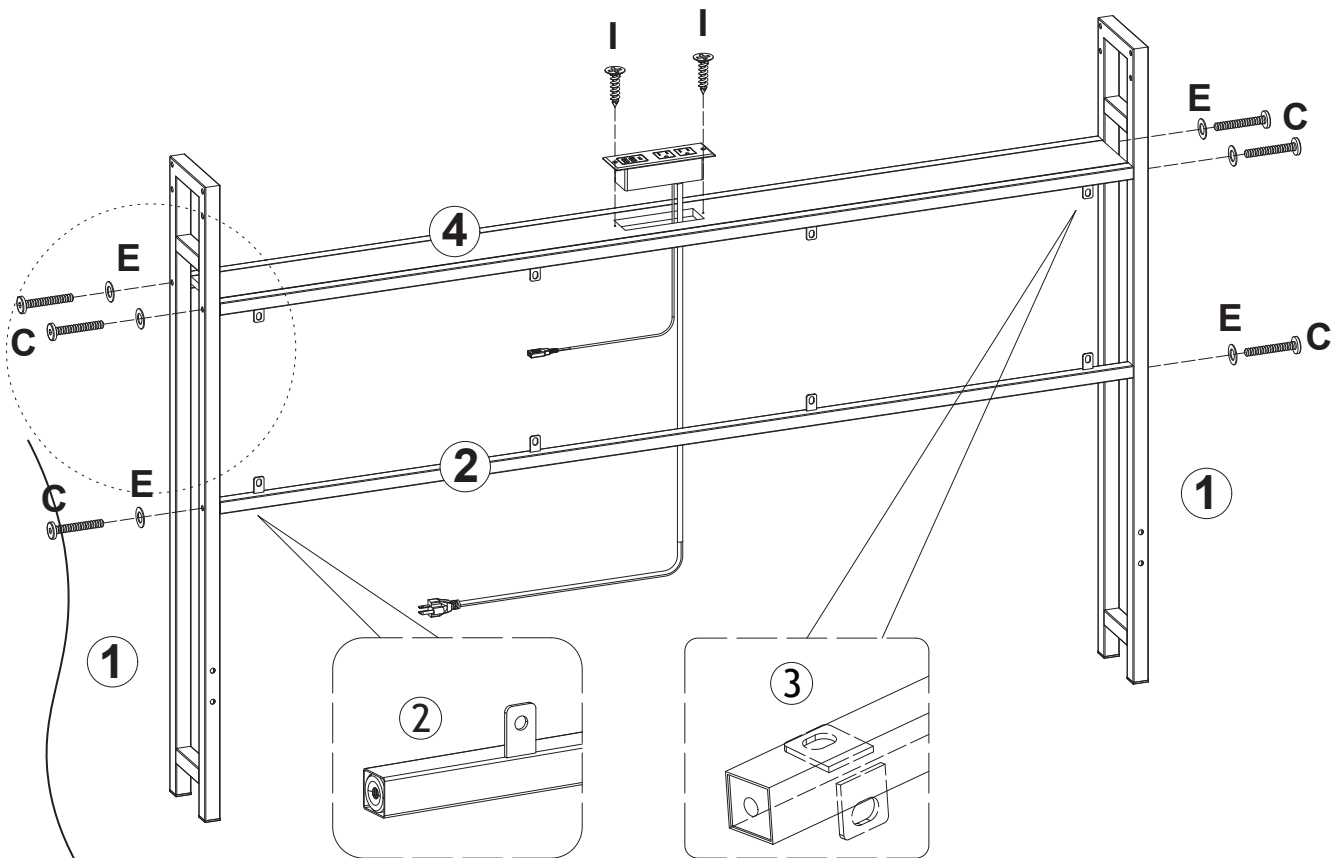

## STEP 2

1. Connect HD side frames (1), tube (2) and assembled panel (4), then tighten them with screw (C) and washer (E).
2. Fix charging socket (H) to panel (4) with screw (I).

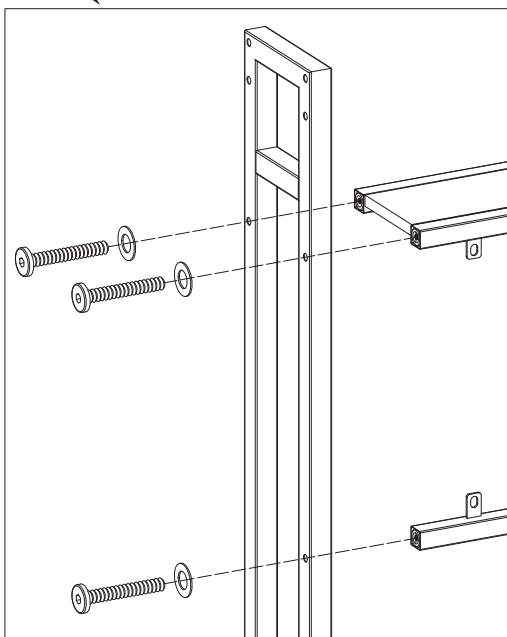

Pay attention to the installation direction.

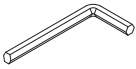



CODE	HARDWARE	QTY
C	 M6x40	6
E	 M13x8x1	6
F	 S4	1
H		1
I	 M3x10	2

# Assembly Steps

## STEP 3

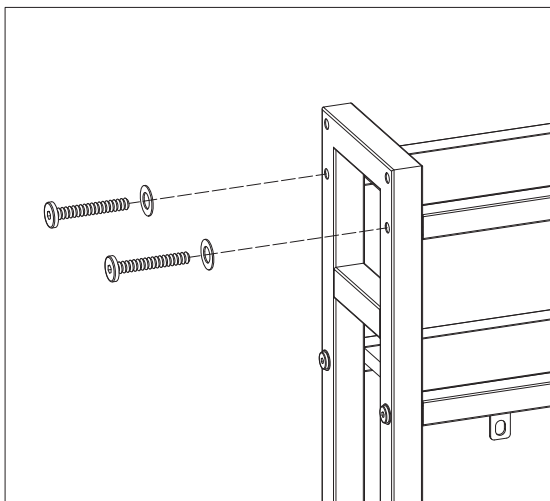
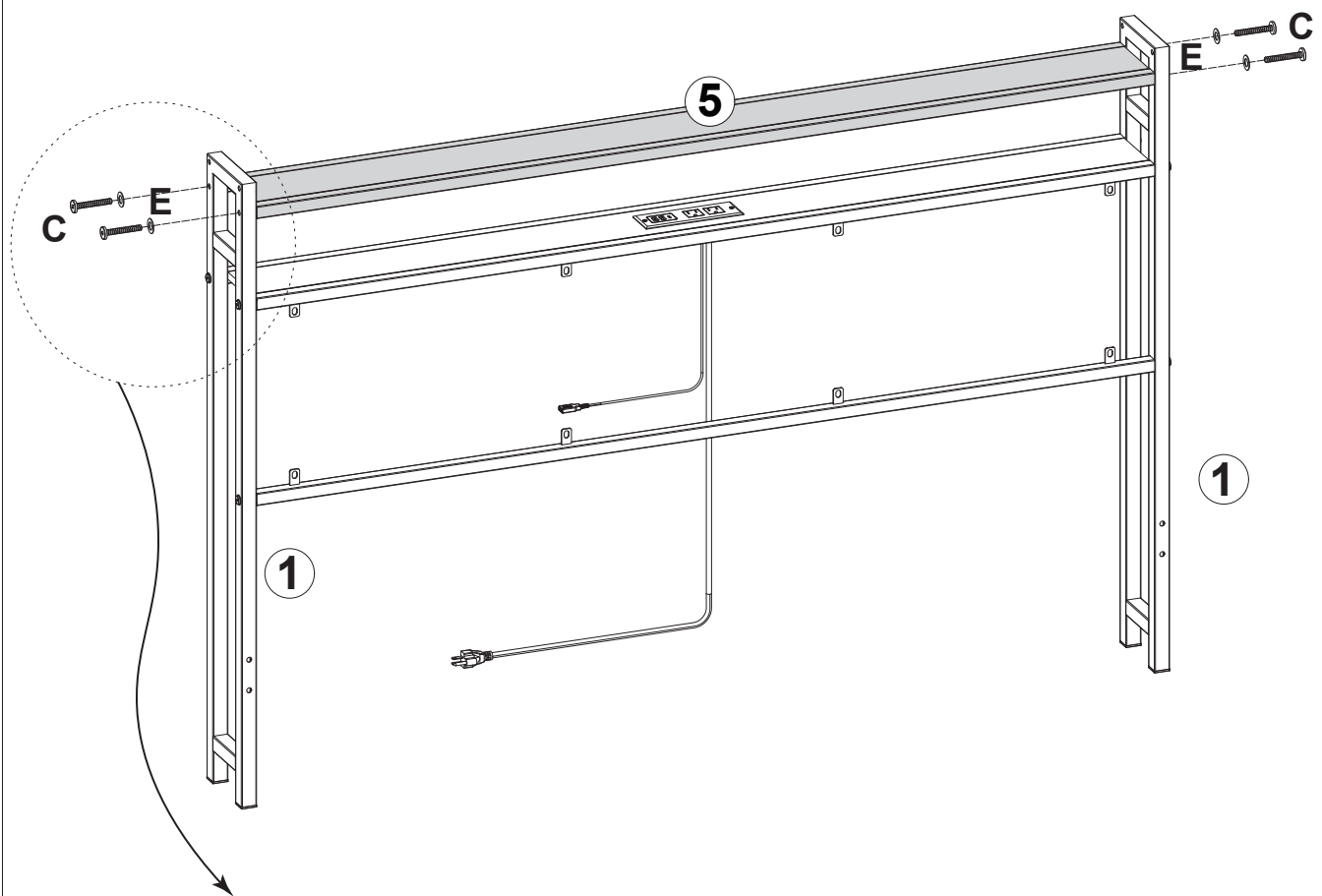
Connect panel (5) and assembled frame (STEP 2), then tighten them with screw (C) and washer (E).

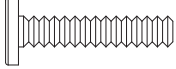

CODE	HARDWARE	QTY
C	 M6x40	4
E	 M13x8x1	4
F	 S4	1

# Assembly Steps

## STEP 4

Fix HD middle front panel (6) to tubes (2), (3) with screw (A).

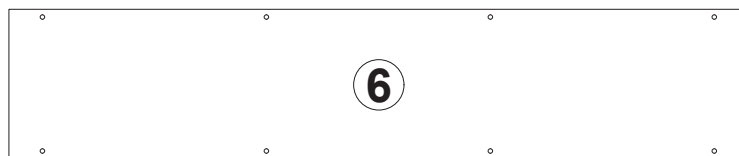
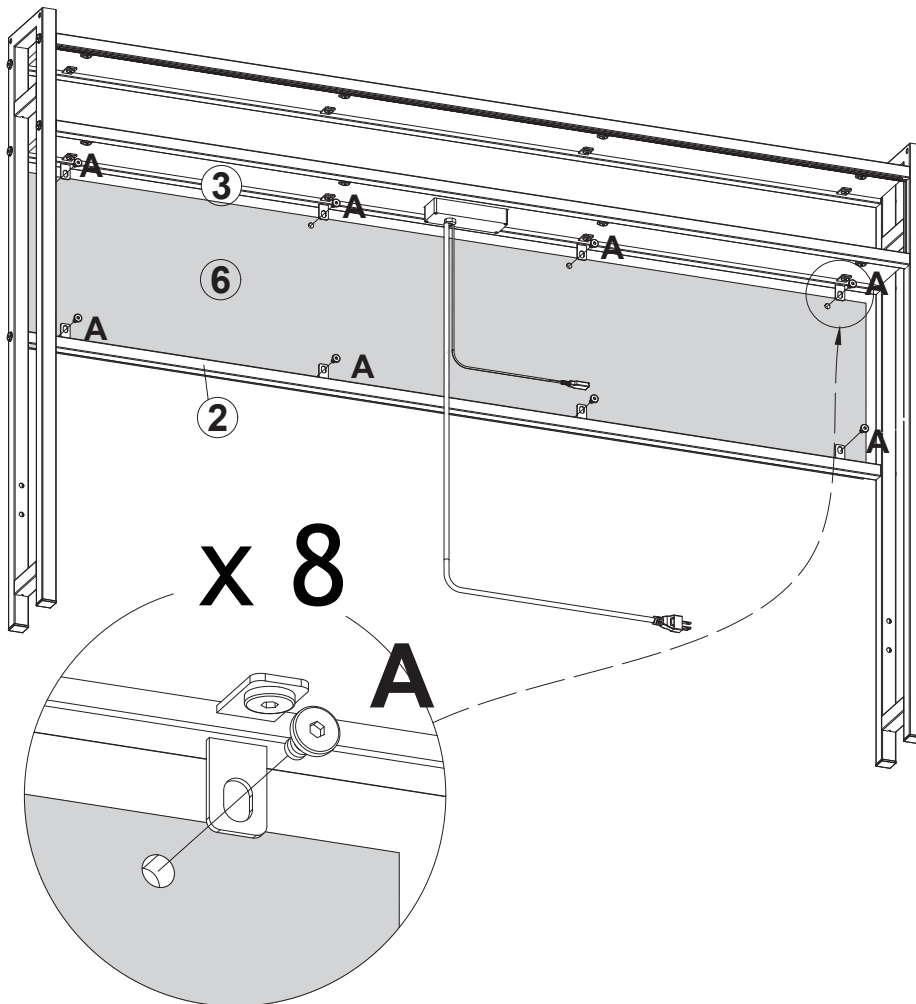

The arrangement of holes is as shown.

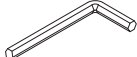
CODE	HARDWARE	QTY
A	 M6x12	8
F	 S4	1

# Assembly Steps

## STEP 5

1. Unfold side rails (7) and center brace (10).
2. Stick the EVA foam (G) on the top of center brace (10).

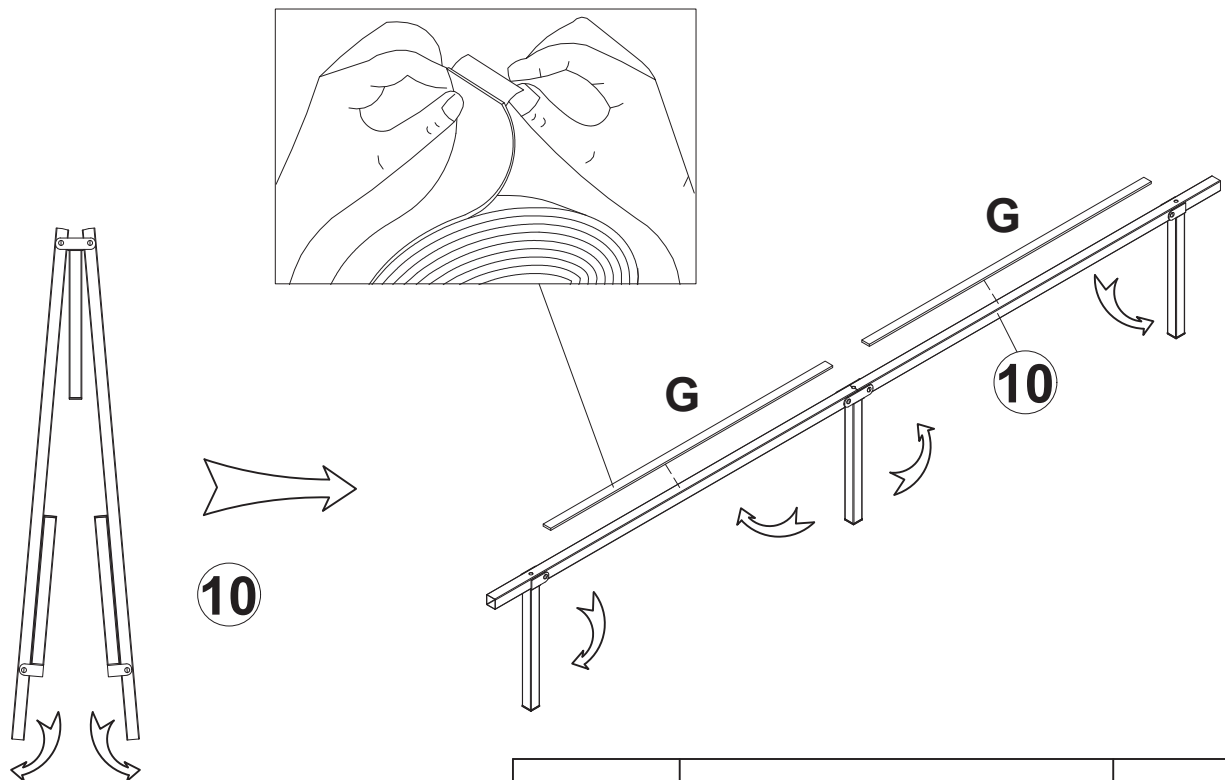
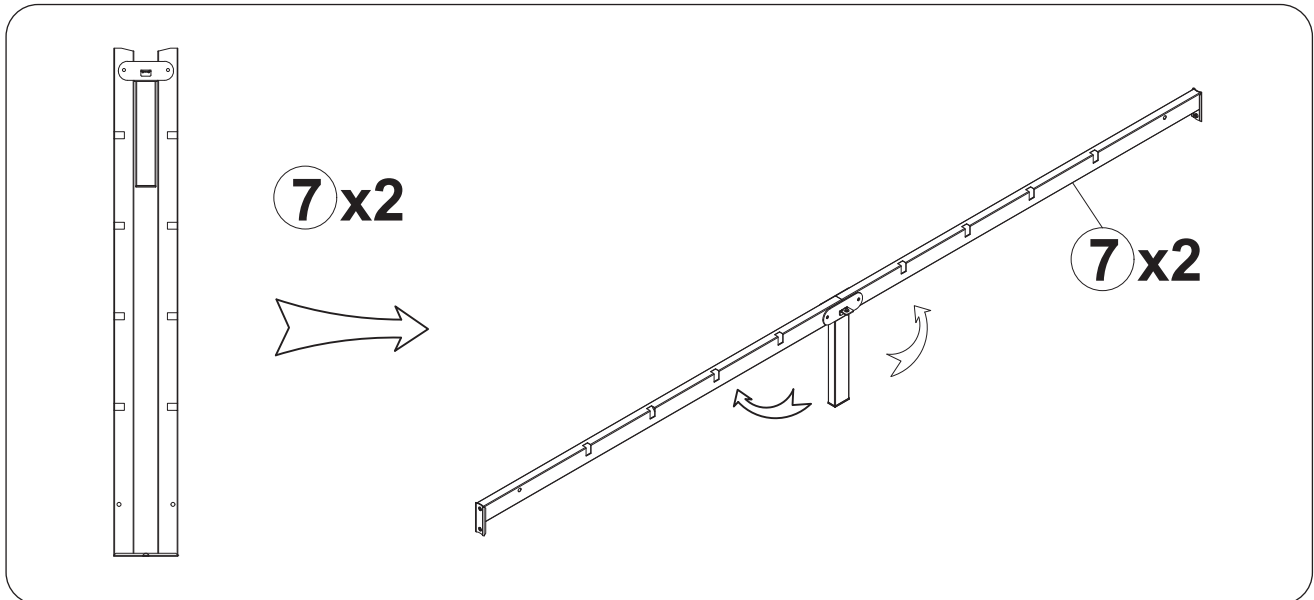

CODE	HARDWARE	QTY
G	 800x14x2	2

## STEP 6

Fix panel (9) to the foot - board frame (8) with screw (A).

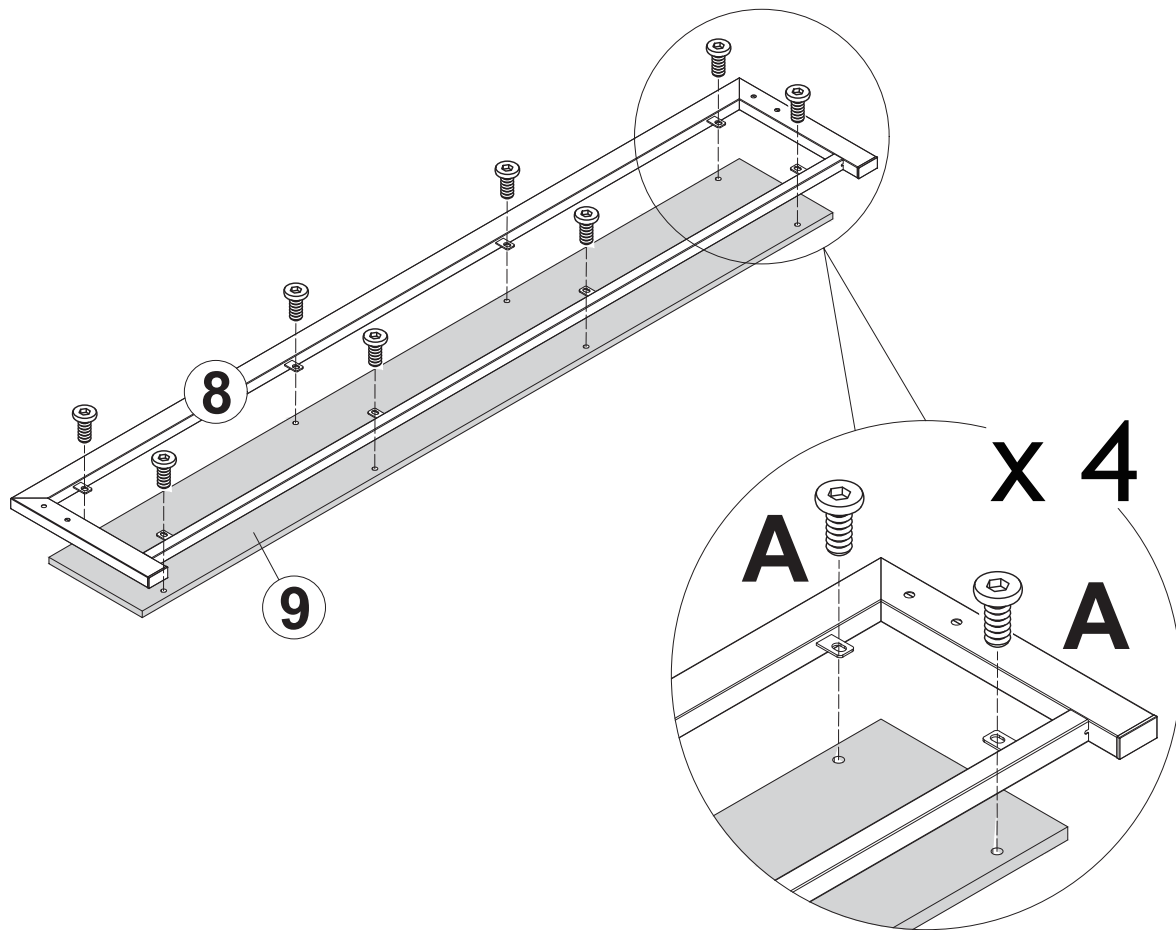

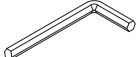

CODE	HARDWARE	QTY
A	 M6x12	8
F	 S4	1

# Assembly Steps

## STEP 7

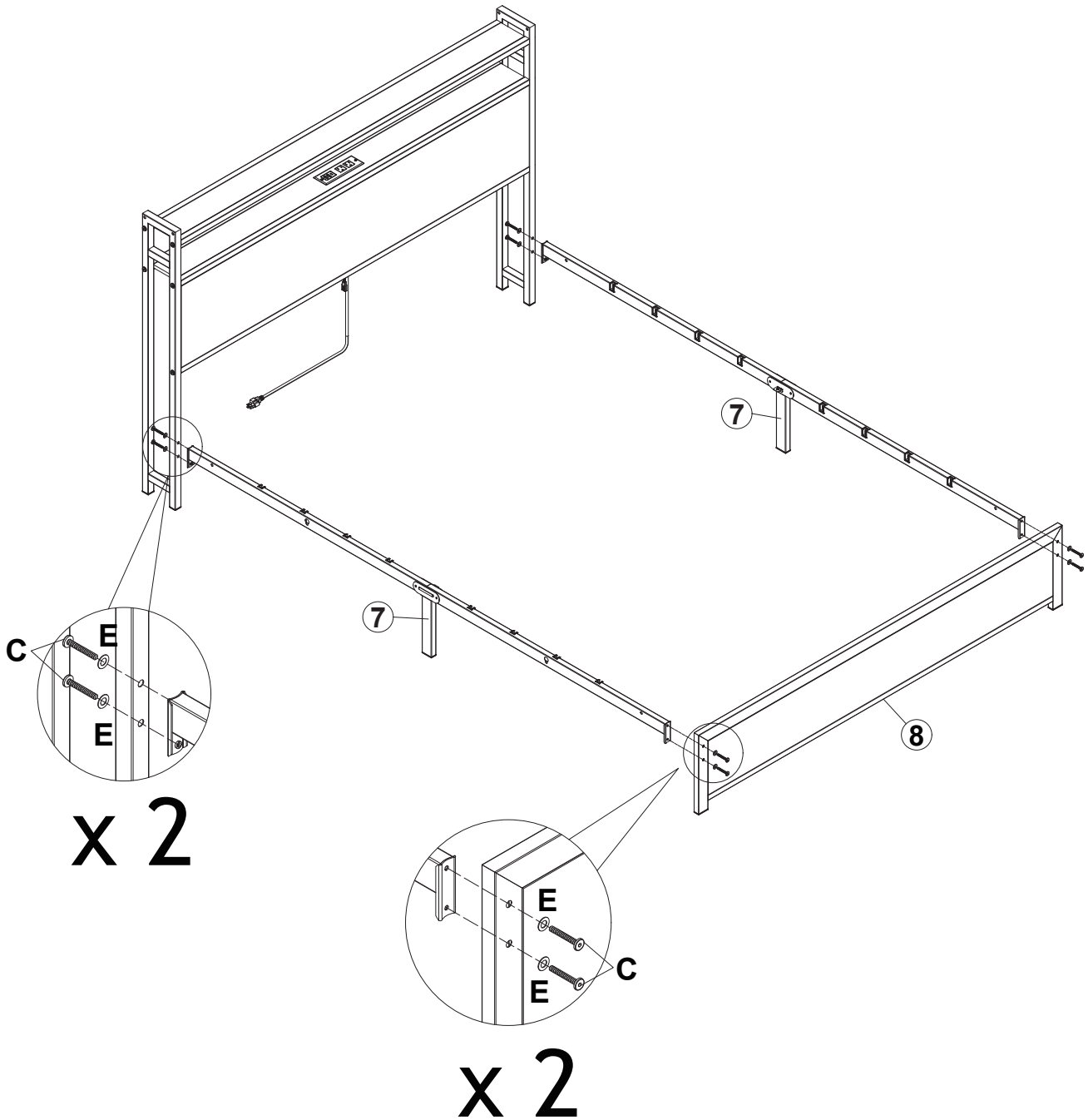
Connect side rail (7) to the already assembled headboard (STEP 4) and footboard (STEP 6), and fix them with screw (C) and washer (E).

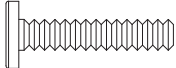

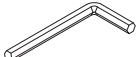

CODE	HARDWARE	QTY
C	 M6x40	8
E	 M13x8x1	8
F	 S4	1

## STEP 8

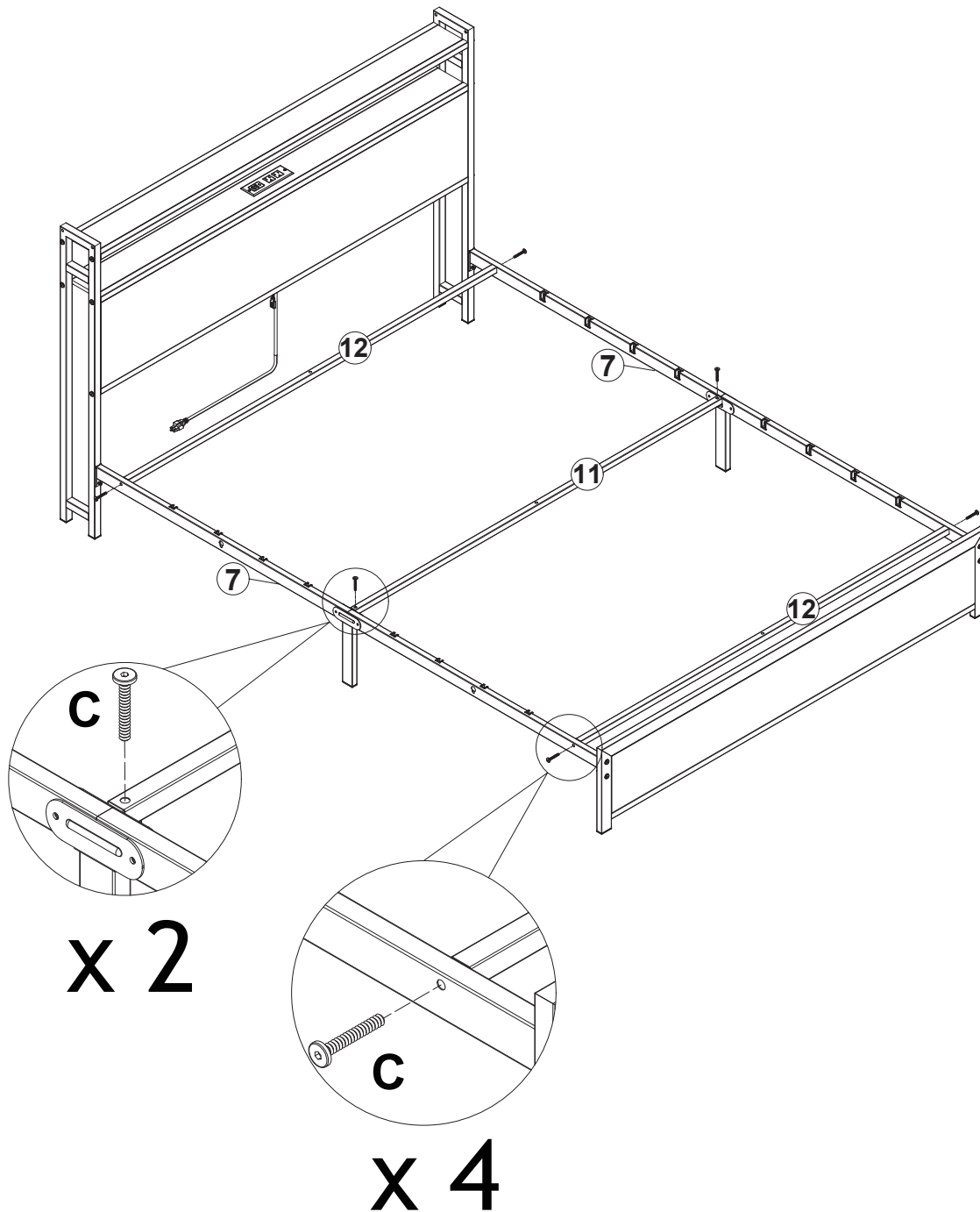
Fix center cross beam (11) and slat with nut (12) to side rails (7) with screw (C).

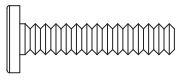

CODE	HARDWARE	QTY
C	 M6x40	6
F	 S4	1

# Assembly Steps

## STEP 9

Fix center brace (10) to center cross beam (11) and slat with nut (12) with the screw (D).

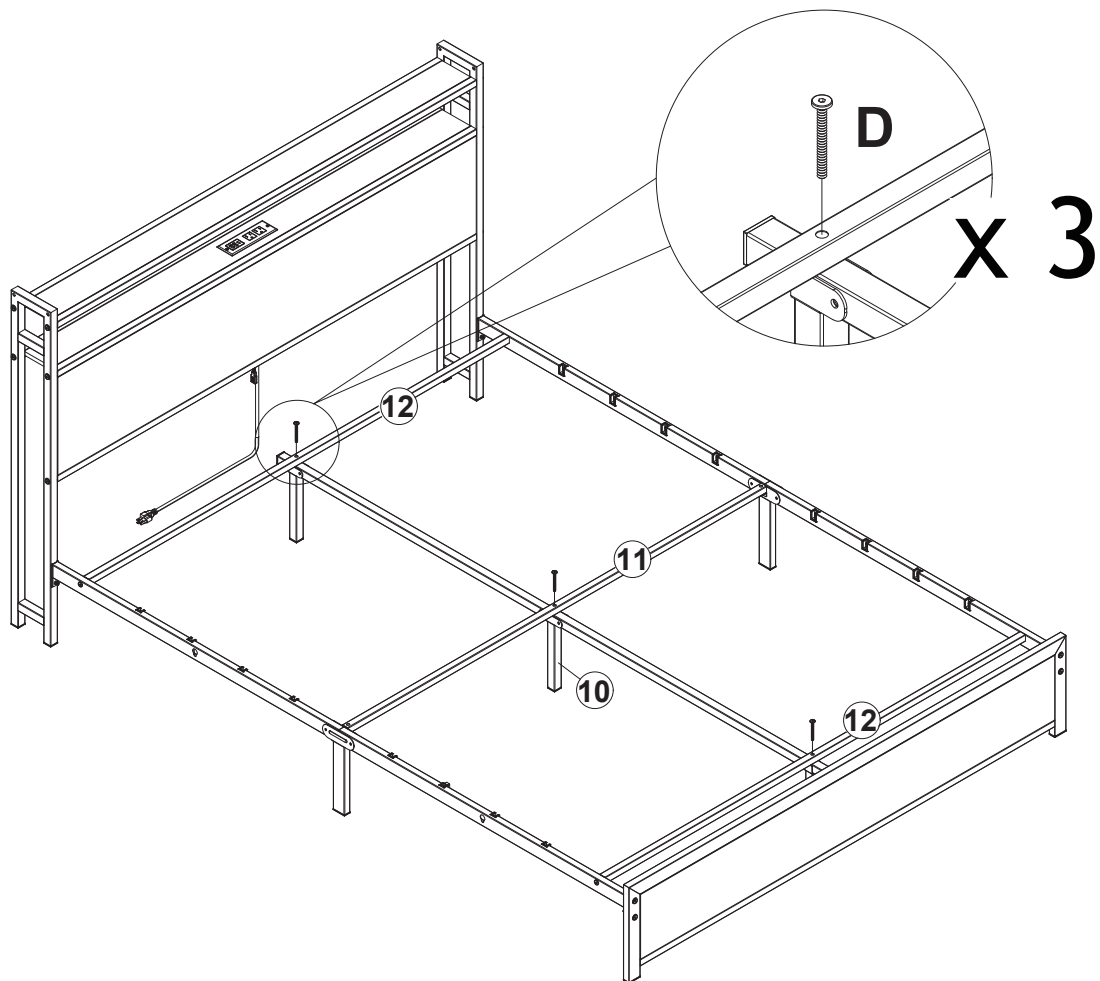

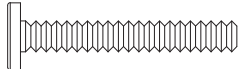
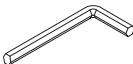
CODE	HARDWARE	QTY
D	 M6x55	3
F	 S4	1

## STEP 10

Insert bed slat (13) into the slots of side rails (7).

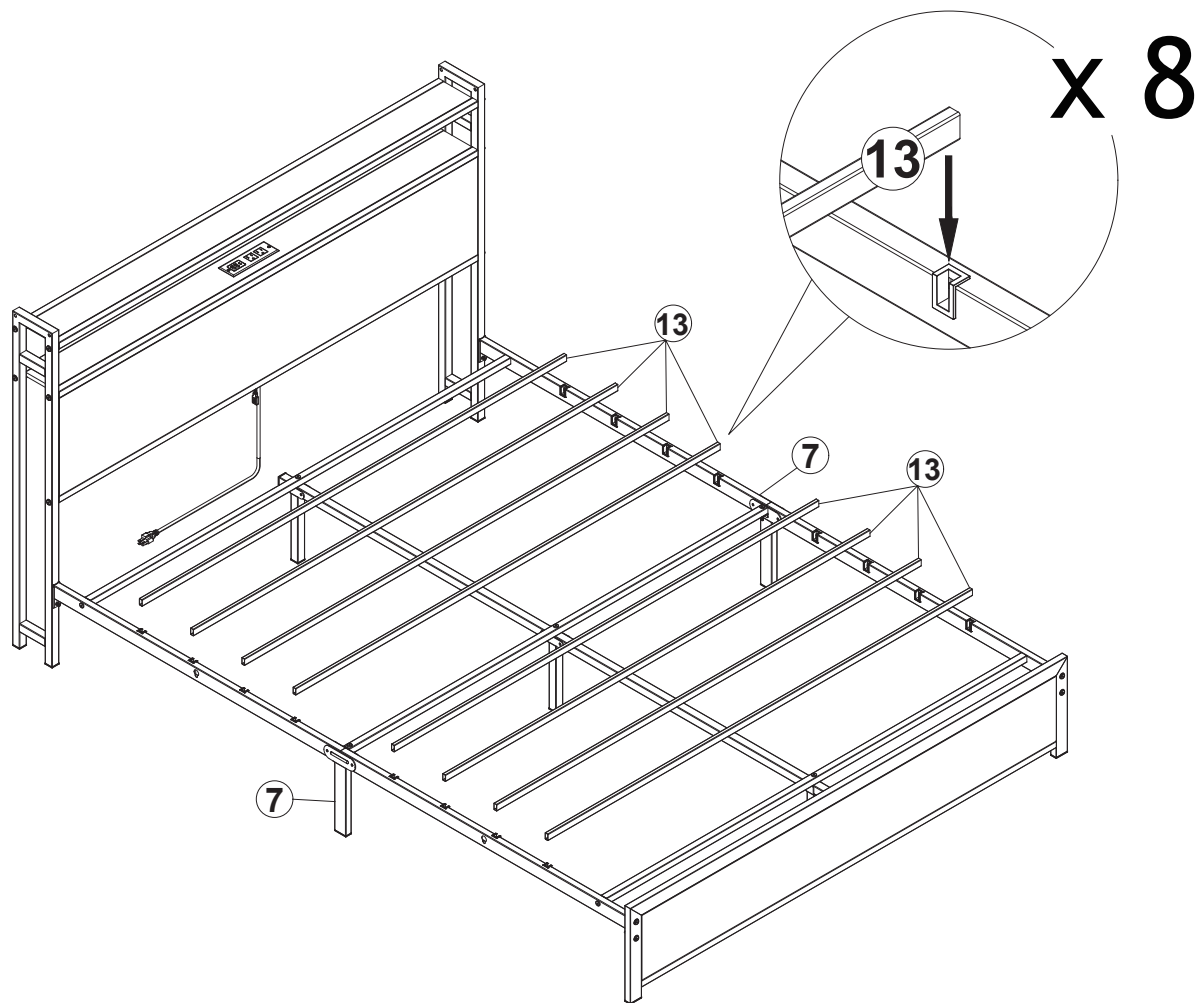





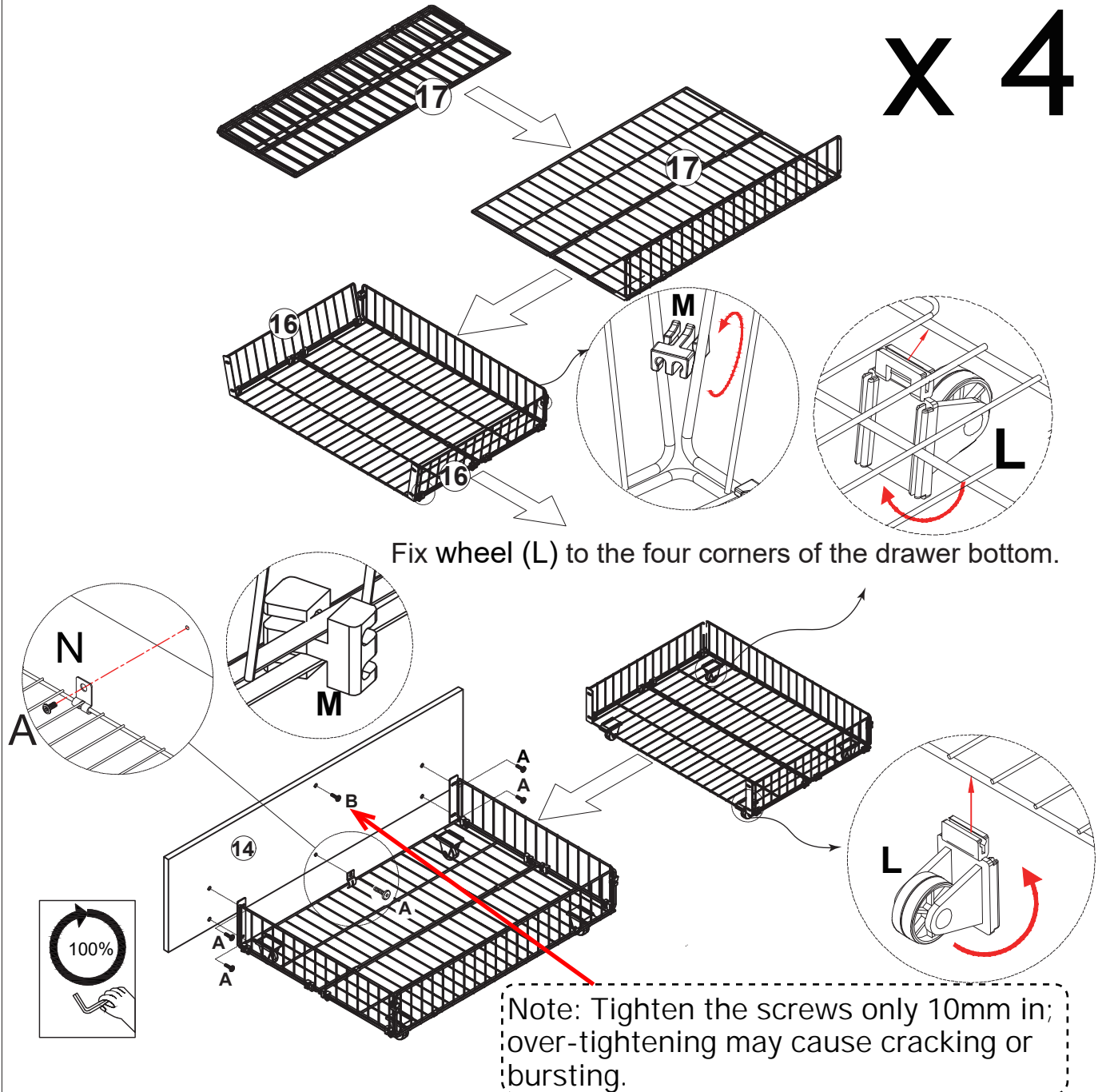

# Assembly Steps

## STEP 11

Unfold drawer bottom frame (17), then connect drawer bottom frame (17) and drawer side frame (16) with drawer clips (N), (M).



Install panels (14) to the assembled drawer frame with screws (A), (B).

CODE	HARDWARE	QTY	CODE	HARDWARE	QTY
A	 M6x12	20	L		16
B	 M6x16	4	M		40
F	 S4	1	N		4

## STEP 12

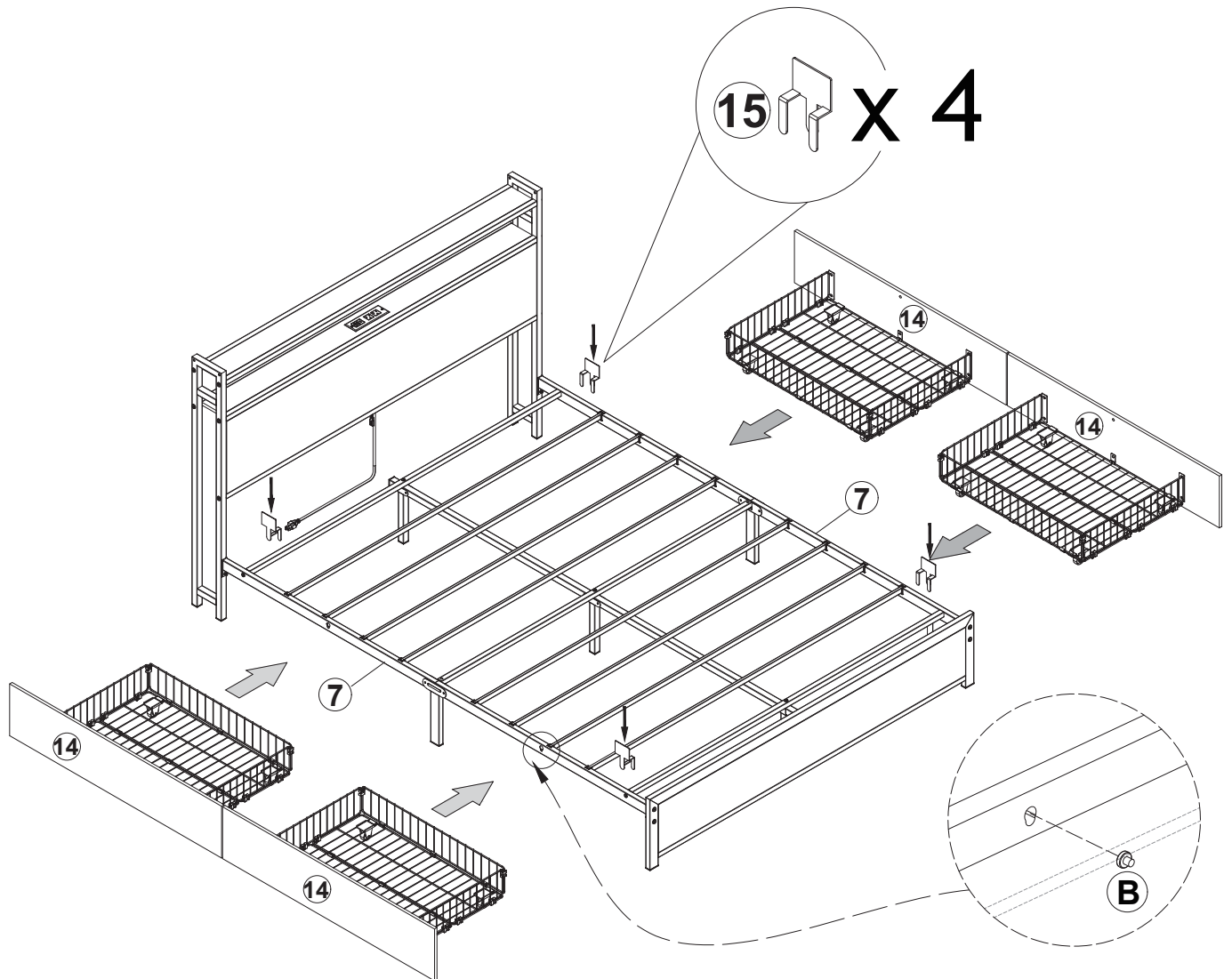

1. Fix the mattress stopper (15) to side rails (7).
2. Push the assembled drawer (STEP 11) under the bed.
3. Make the screw (B) on panel (14) snap into the holes of side rail (7).

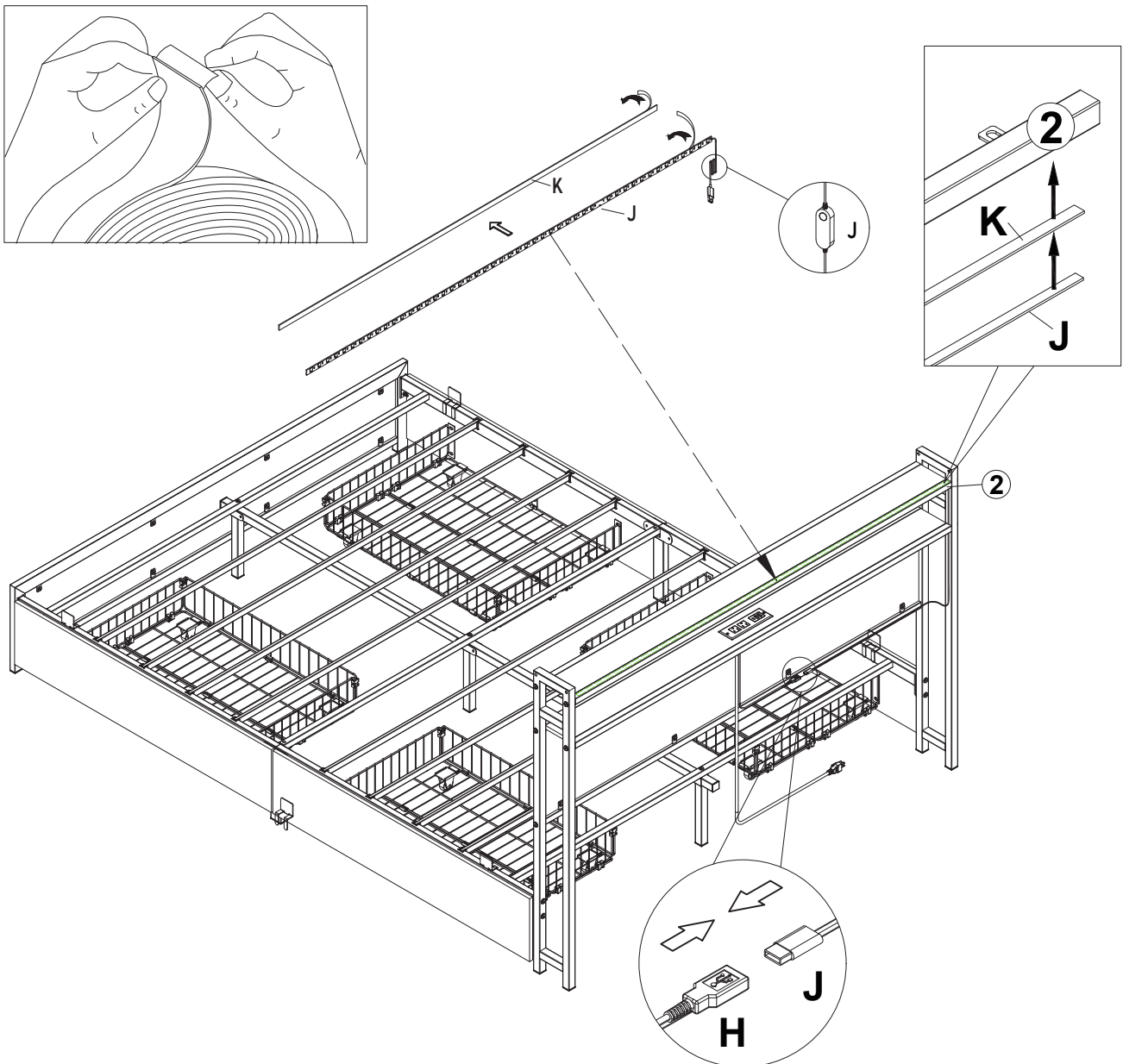

## STEP 13

1. Stick the EVA foam (K) on the bottom of tube (2).
2. Stick the LED light strip (J) on the EVA foam (K).



CODE	HARDWARE	QTY
J	 (1880.1470.1320) x8x2	1
K	 (1880.1470.1320) x10x2	1

## **WARNING**

- **INGESTION HAZARD:** This product contains a button cell or coin battery.
- **DEATH** or serious injury can occur if ingested.
- A swallowed button cell or coin battery can cause **Internal Chemical Burns** in as little as **2 hours**.
- **KEEP** new and used batteries **OUT OF REACH of CHILDREN**
- **Seek immediate medical attention** if a battery is suspected to be swallowed or inserted inside any part of the body.



## **WARNING**

- **INGESTION HAZARD:** This product contains a button cell or coin battery.
- **DEATH** or serious injury can occur if ingested.
- A swallowed button cell or coin battery can cause **Internal Chemical Burns** in as little as **2 hours**.
- **KEEP** new and used batteries **OUT OF REACH Of CHILDREN**
- **Seek immediate medical attention** if a battery is suspected to be swallowed or inserted inside any part of the body.

