

KING ASSEMBLY INSTRUCTION

Thank you for purchasing this quality product. Be sure to check all packing material carefully for small parts which may have come loose inside the carton during shipment. Separate, identify and count all parts and hardware. Compare with the parts list to be sure all parts are present.

IMPORTANT : PLEASE READ INSTRUCTION BEFORE STARTING THE ASSEMBLY.

"DO NOT TIGHTEN SCREWS UNTIL COMPLETELY ASSEMBLED"

"DO NOT OVERTIGHT ANY HARDWARE"

WARNING : SMALL PARTS AND HARDWARE NOT FOR CHILDREN UNDER 3 YEARS. ADULT ASSEMBLY REQUIRED.

TABLE OF CONTENTS

HARDWARES LIST	PAGE 2
PARTS LIST	PAGE 3
PARTS' LOCATION	PAGE 4
ASSEMBLY STEPS	PAGE 5 - 9

ASSEMBLY TOOLS REQUIRED

1.Screwdriver (not provide)

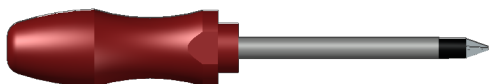

2.Hammer (not provide)

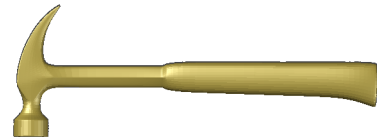







Skip the power drill this time.

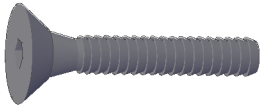
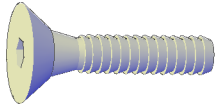
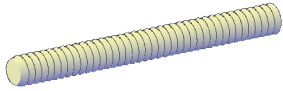
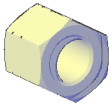

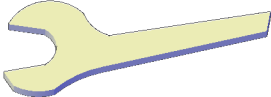

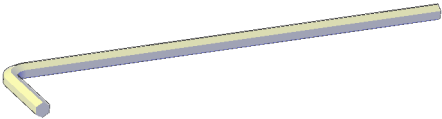

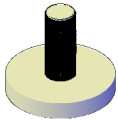
ASSEMBLY INSTRUCTION

HARDWARES LIST

ITEM	DESCRIPTION	DRAWING	QTY
A	JCBC SCREW M6 x 50 MM (BLK)		6 PCS
B	JCBC SCREW M6 x 40 MM		8 PCS
C	STUD BOLT M6 x 60 MM		8 PCS
D	HEX NUT M6		8 PCS
E	BEND WASHER Ø7.5 MM		8 PCS
F	BEND WASHER 3013		8 PCS
G	SPANNER 10 MM (M6)		1 PC
H	CSK SCREW M4 x 25 MM		8 PCS
I	M4 ALLEN KEY		1 PC
J	M6x19 MM FLAT WASHER		14 PCS
K	M6x12 MM SPRING WASHER		14 PCS
L	SUPPORT LEG ADJUSTABLE FEET		8 PCS

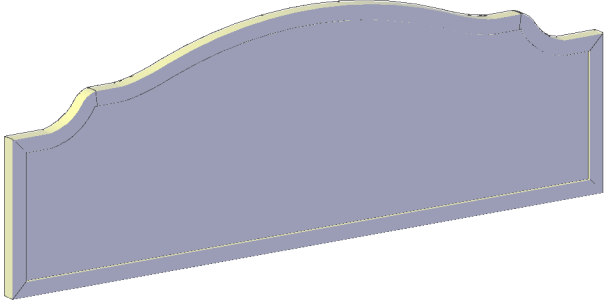
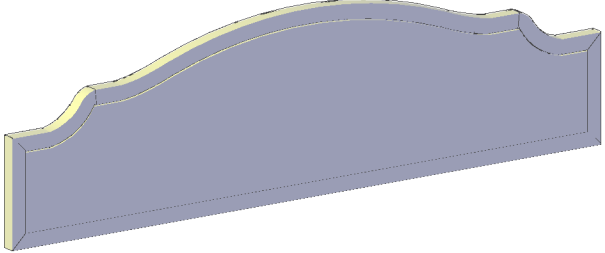
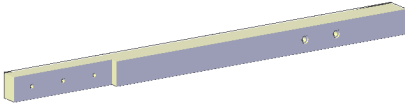
ASSEMBLY INSTRUCTION

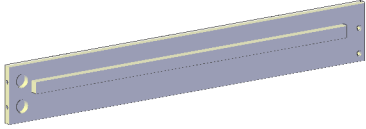
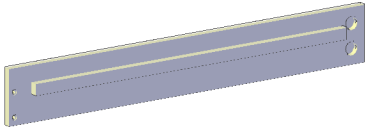
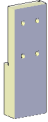
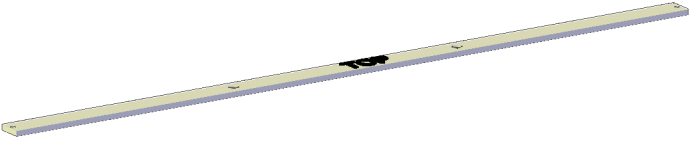
PARTS LIST

ITEM	DESCRIPTION	DRAWING	QTY
1	HEADBOARD		1 PC
2	FOOTBOARD		1 PC
3	HEADBOARD LEG		2 PCS
4	FOOTBOARD LEG		2 PCS
5	SIDE RAIL (i)		2 PCS
6	SIDE RAIL (ii)		2 PCS
7	SIDE RAIL LEG		2 PCS
8	SLAT		4 PCS
9	SUPPORT LEG		8 PCS

ASSEMBLY INSTRUCTION

PARTS LOCATION

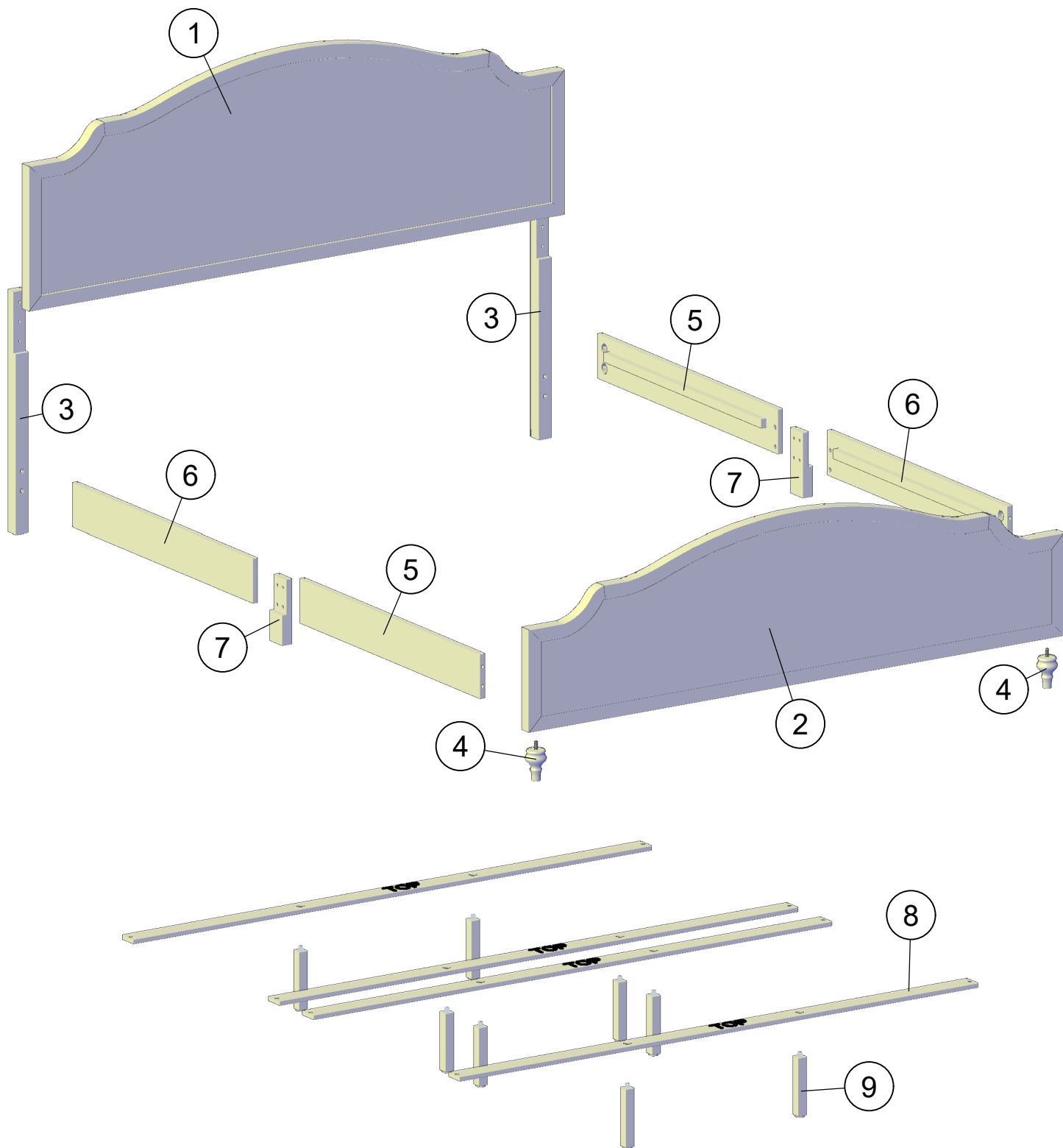

ASSEMBLY INSTRUCTION

STEP 1

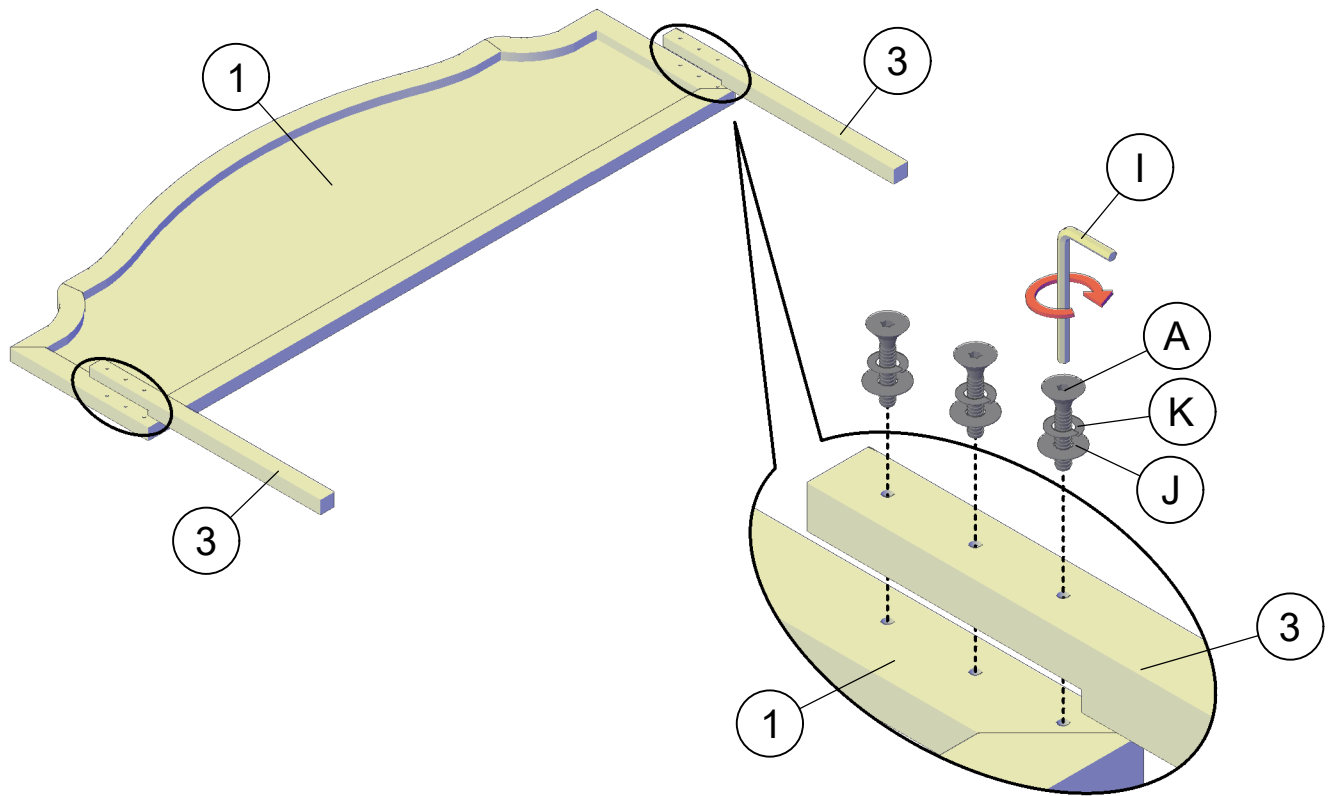

STEP 2

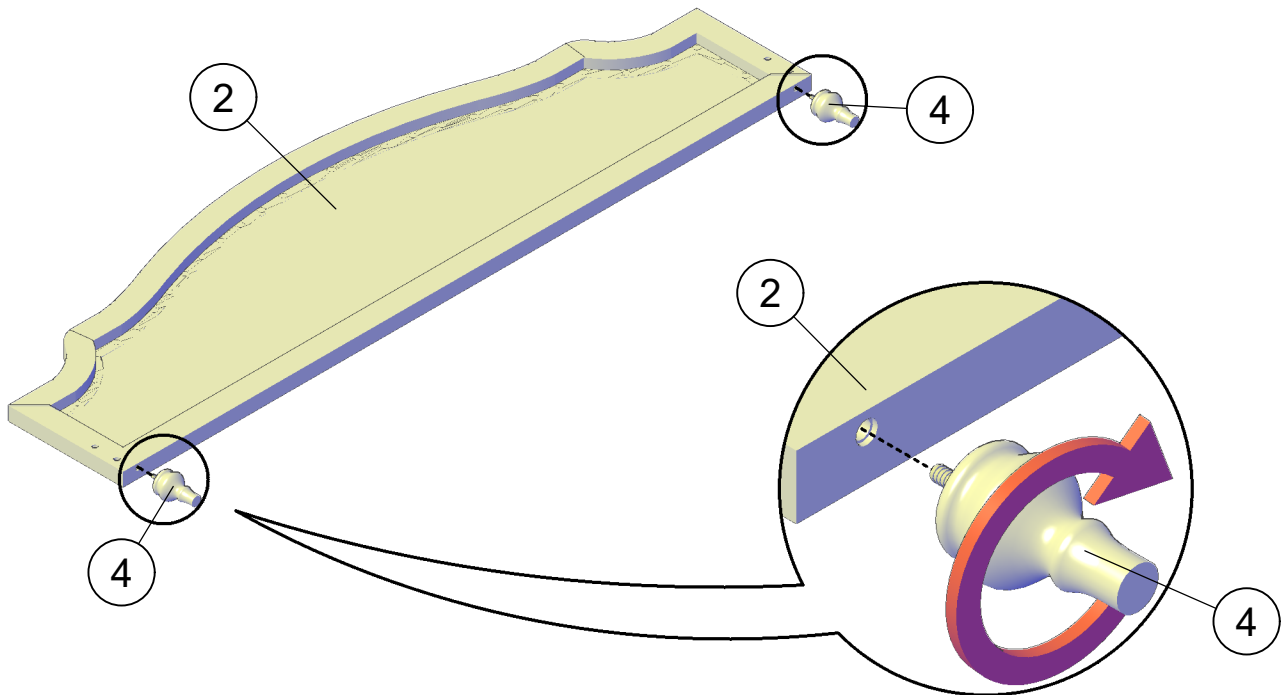

ASSEMBLY INSTRUCTION

STEP 3

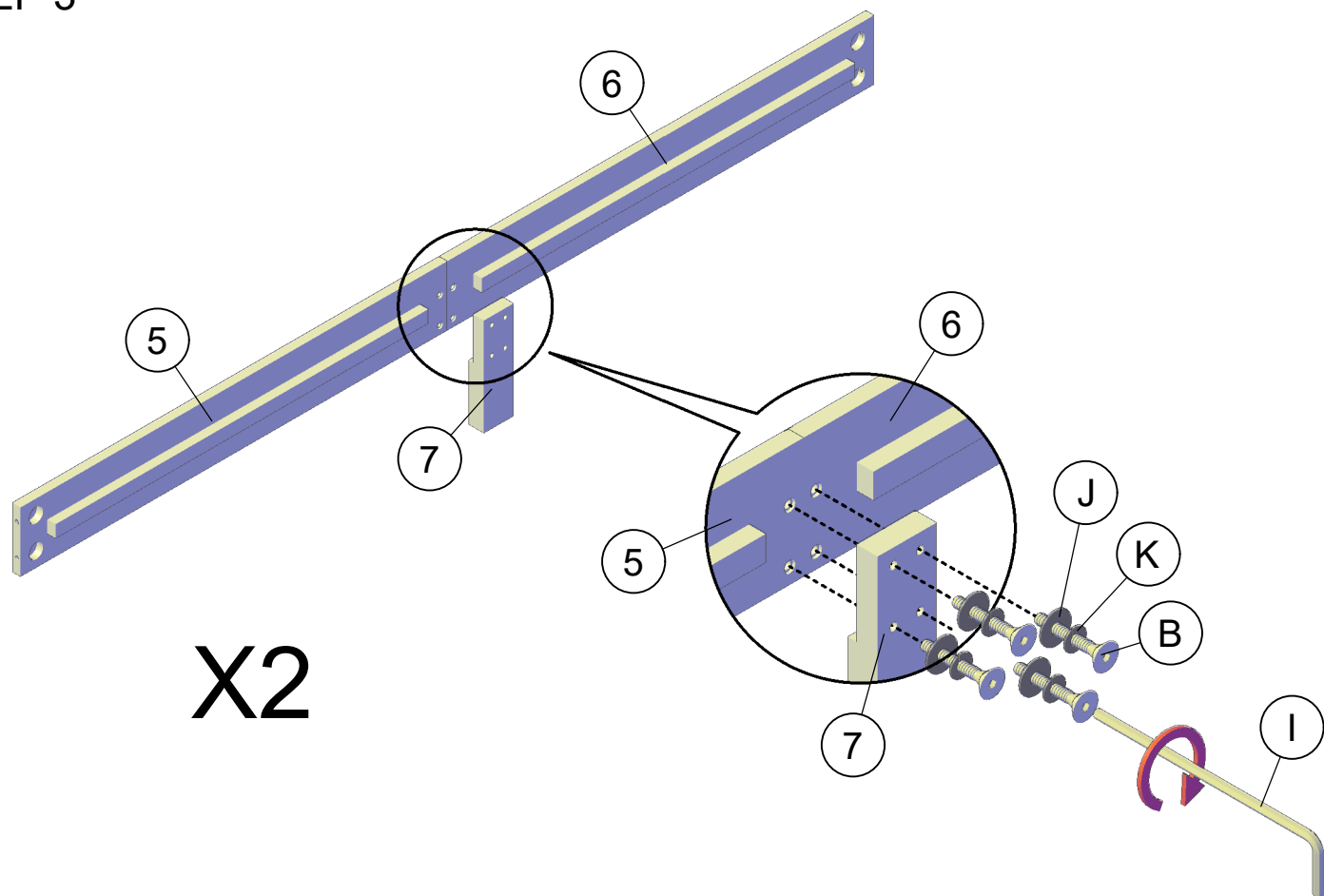

STEP 4

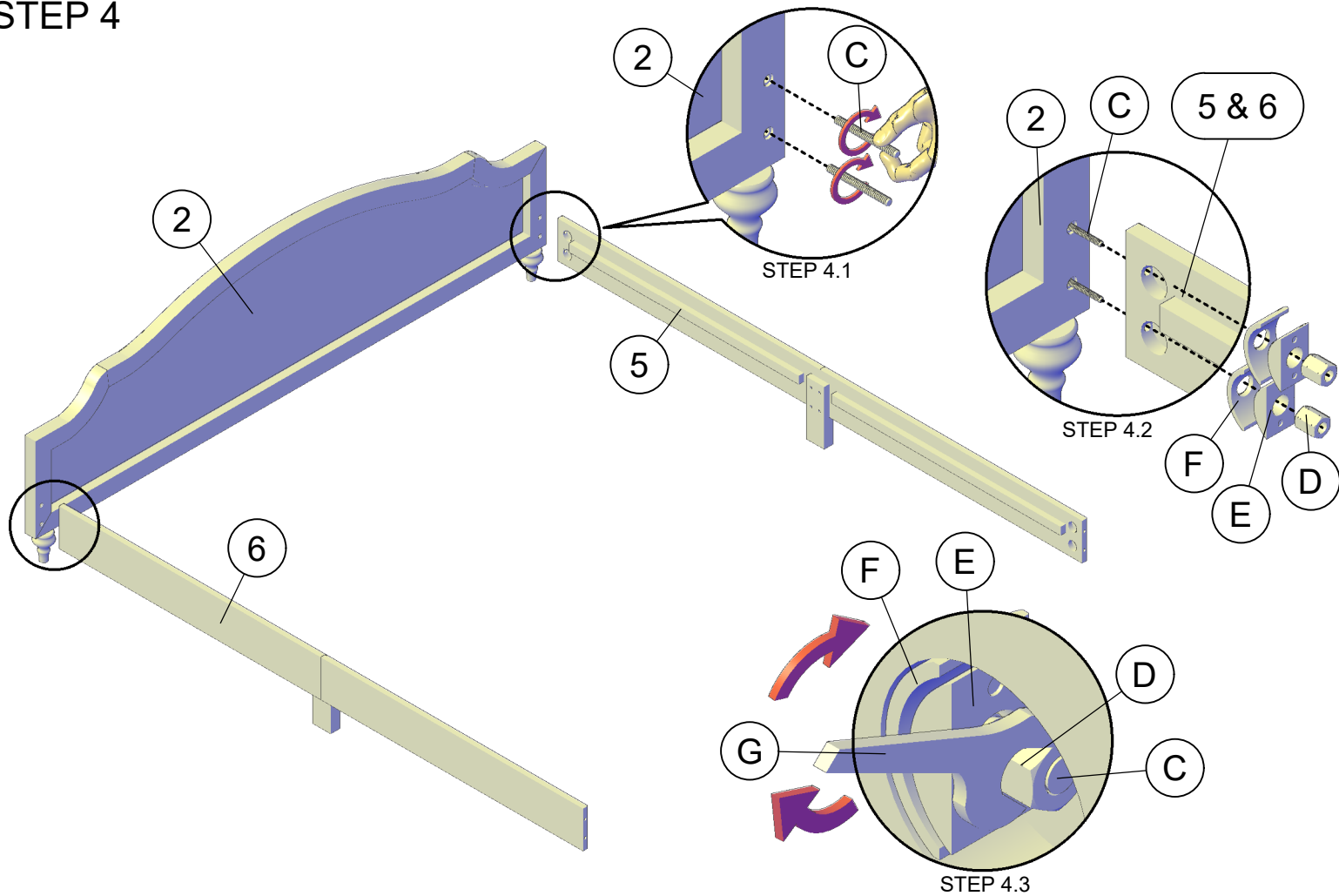

ASSEMBLY INSTRUCTION

STEP 5

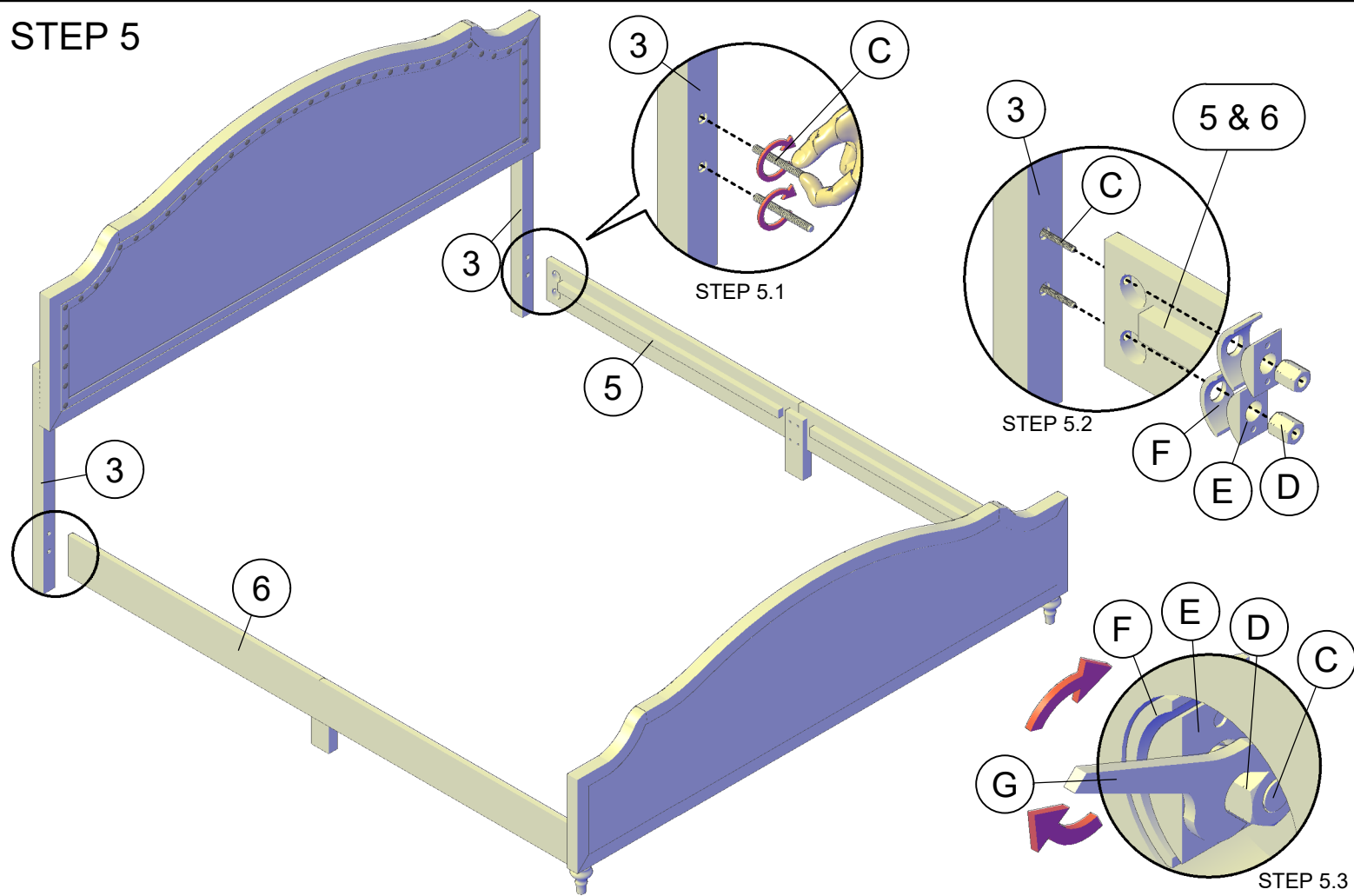

STEP 6

X4

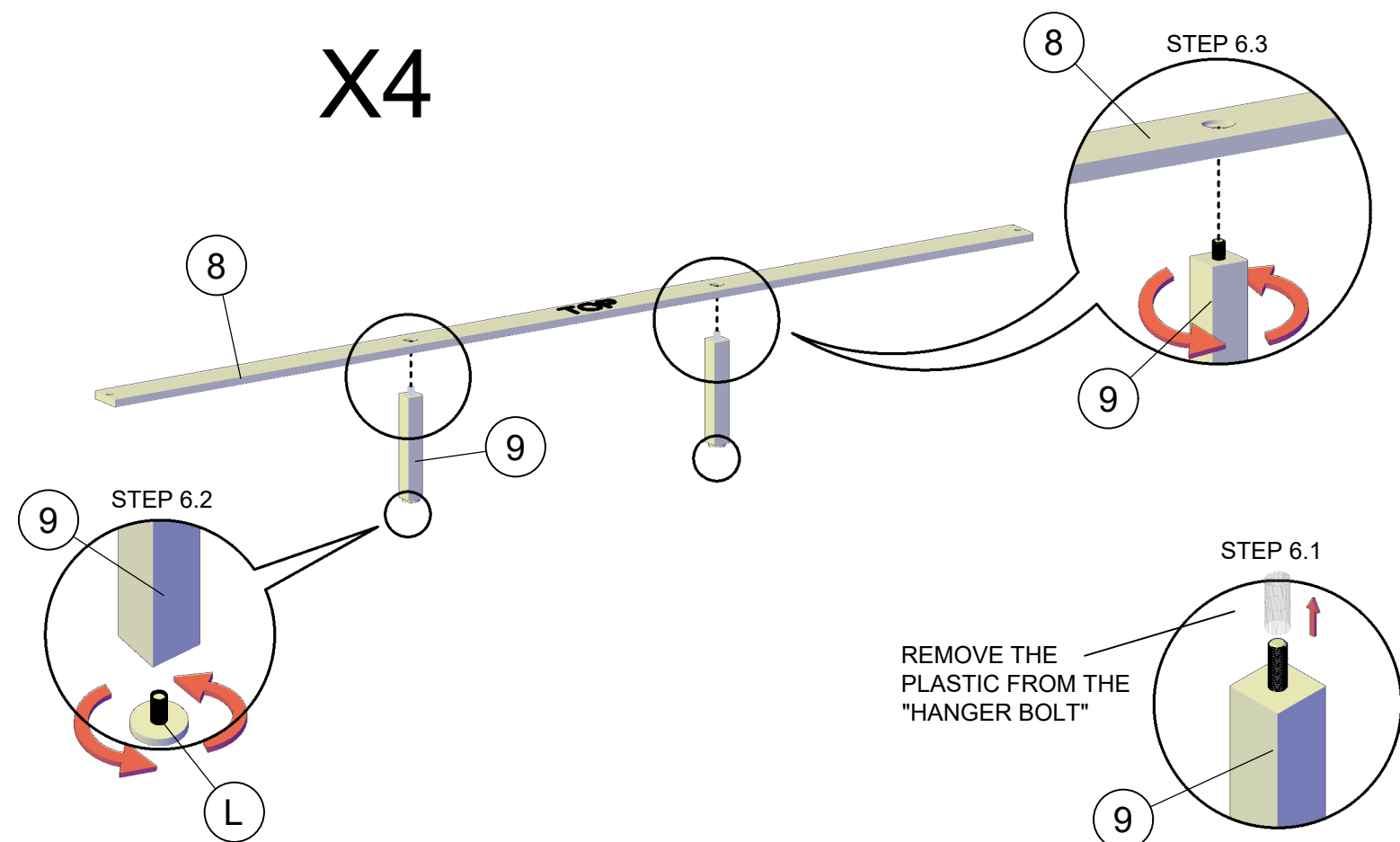

ASSEMBLY INSTRUCTION

STEP 9

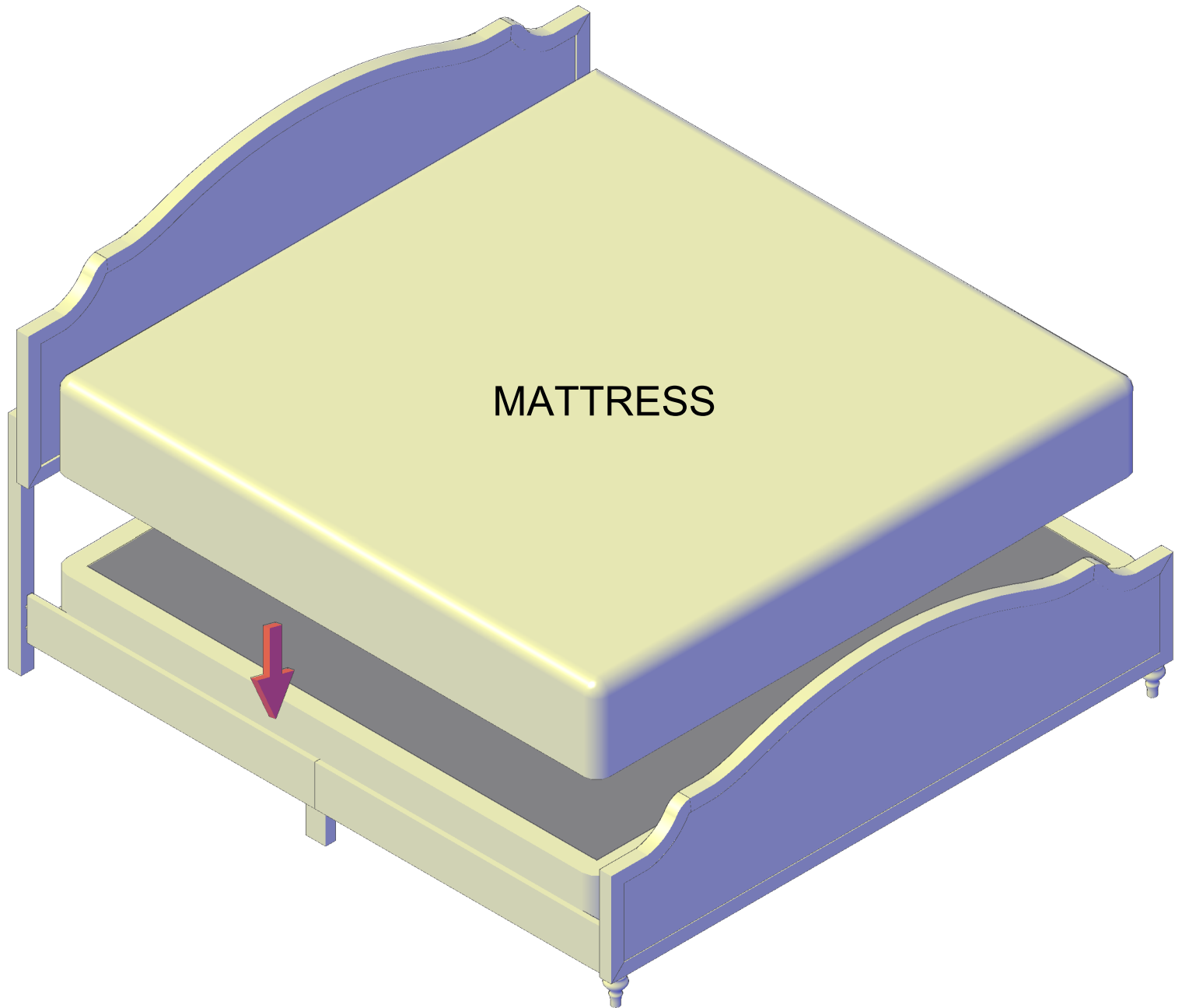

MATTRESS NOT INCLUDED

ASSEMBLY
COMPLETE