

# Assembly Instructions

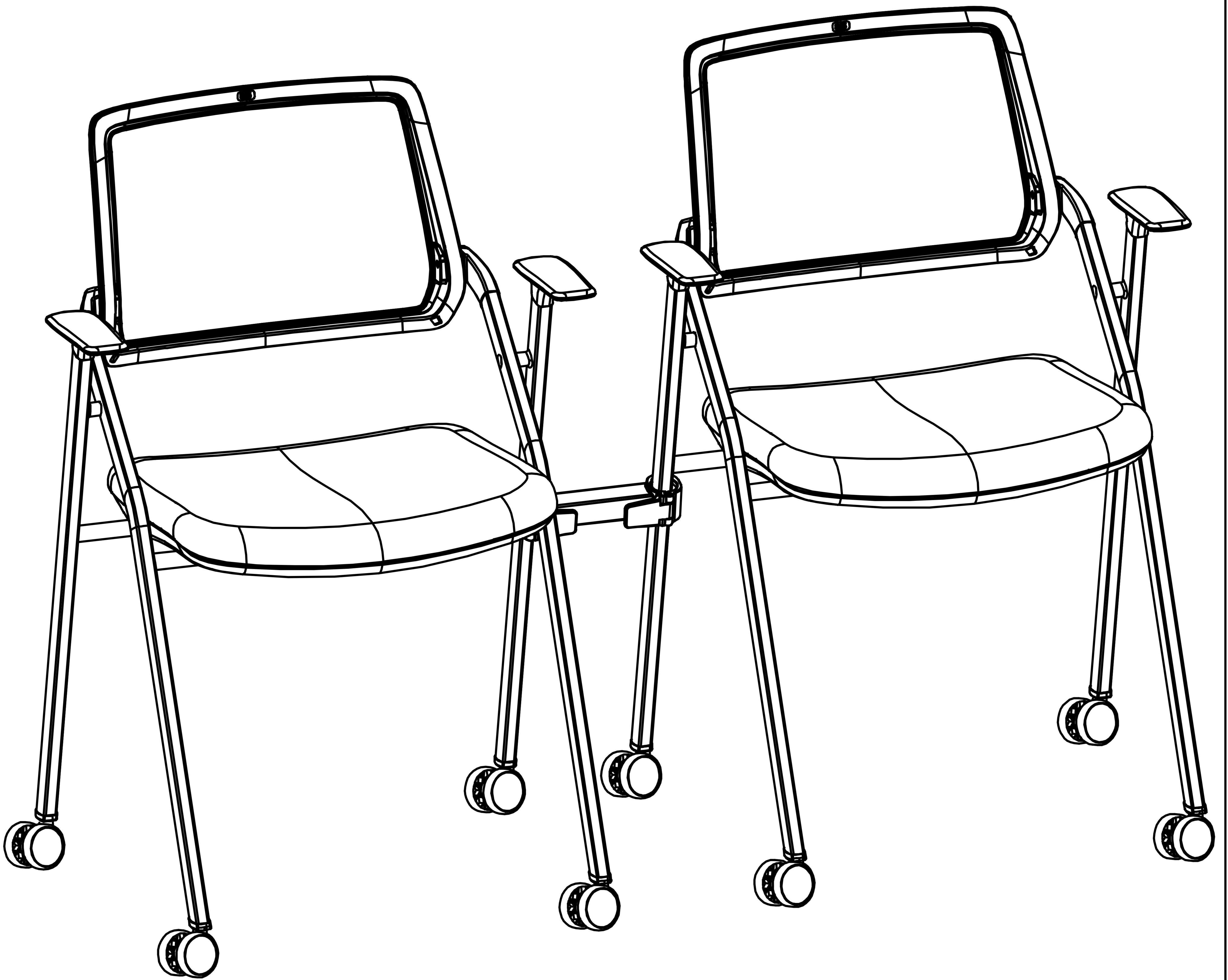

# Assembly Instructions

## INSTALLATION GUIDE

**ONE PERSON ASSEMBLY: 5 MINUTES (APPROXIMATE)**

### BEFORE ASSEMBLY

1. Remove all packaging materials, staples and packing straps from the carton.
2. Confirm with Parts Checklist in Page 3.

### ATTENTION

1. Leave sufficient room for assembly.
2. Do not assemble on the ground that may hurt the product.
3. Do not over-tighten any fittings as it may cause damage.
4. **DO NOT USE POWER TOOLS TO ASSEMBLE THIS PRODUCT.**
5. Do not sit or stand on it before the assembly is complete.

### DAILY MAINTENANCE

1. Recommended for indoor use only.
2. Wipe with a soft, dry cloth. Keep away from abrasives and household cleaners.
3. Check all the fittings periodically and re-tighten if necessary. Do not use the product if any part is damaged or broken.

## Office Desk Chair Warranty Policy

Office desk chairs are warranted from the date of purchase against defects in materials and workmanship, as detailed below:

- 1 year on all non-moving metal parts;
- 1 year on upholstered PU leather and foam;
- 1 year on component parts, including the control mechanism, gas cylinder, wood, plastic parts, base, and casters.

To make a warranty claim, please provide the model number, proof of purchase, a description of the issue, and clear photos showing the problem.

Once the issue is verified, the following solutions will be provided:

- a) Replacement parts will be sent;
- b) A replacement product will be provided if necessary. In such cases, the original item must be returned to the warehouse. Return shipping costs will be covered.

---

## Return Policy

A 30-day free return policy is available from the date of receipt. Prepaid return labels will be provided, and return shipping costs will be covered.

PARTS CHECK LIST

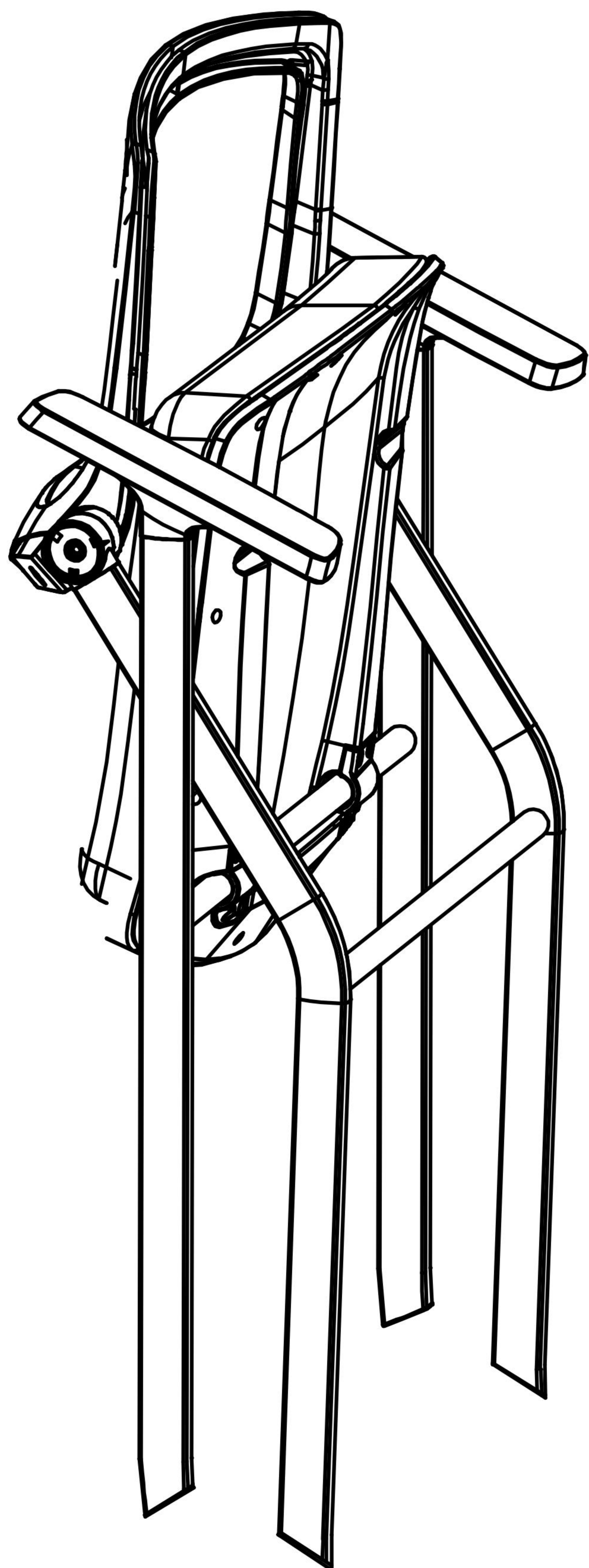

Ax2

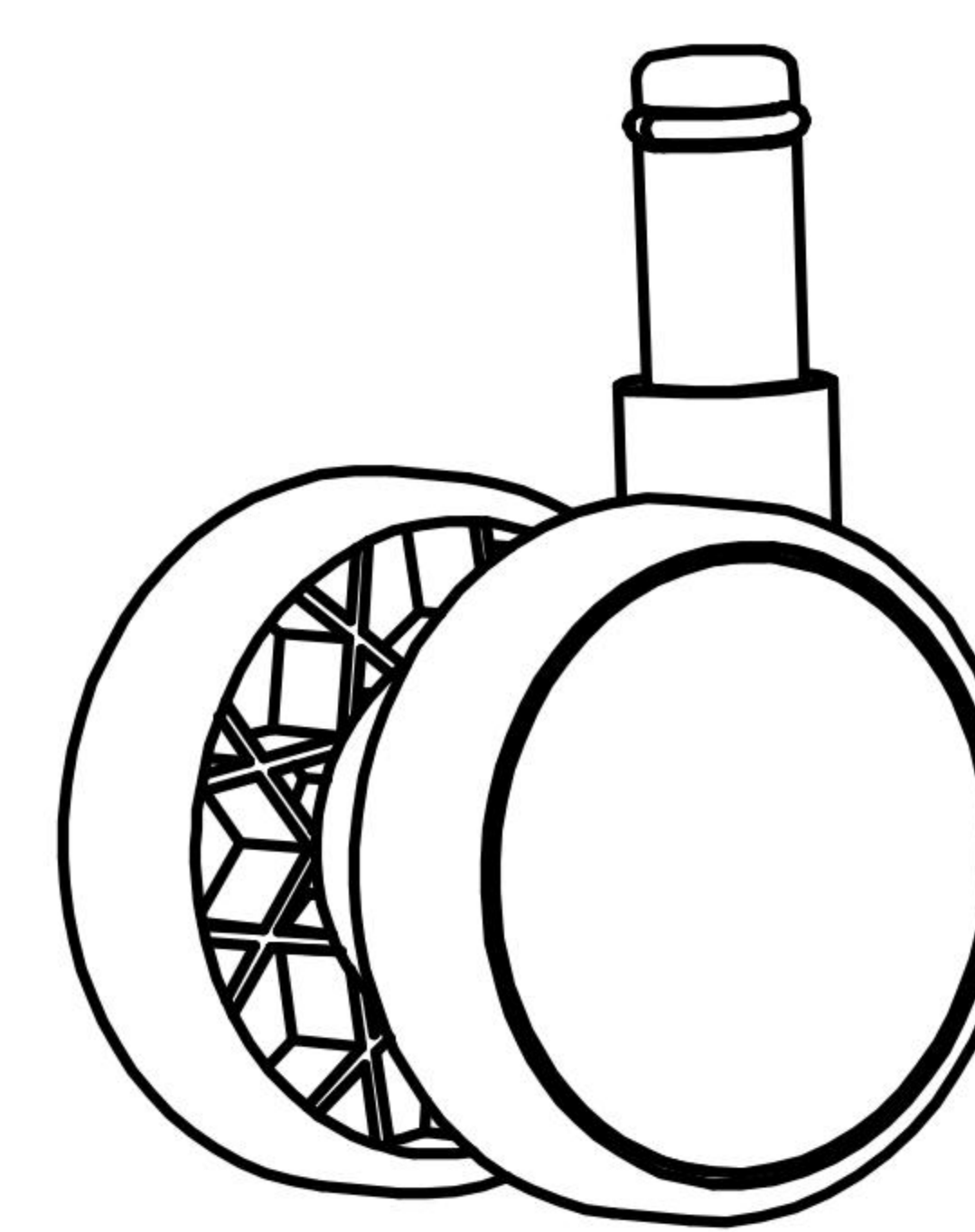

Bx8

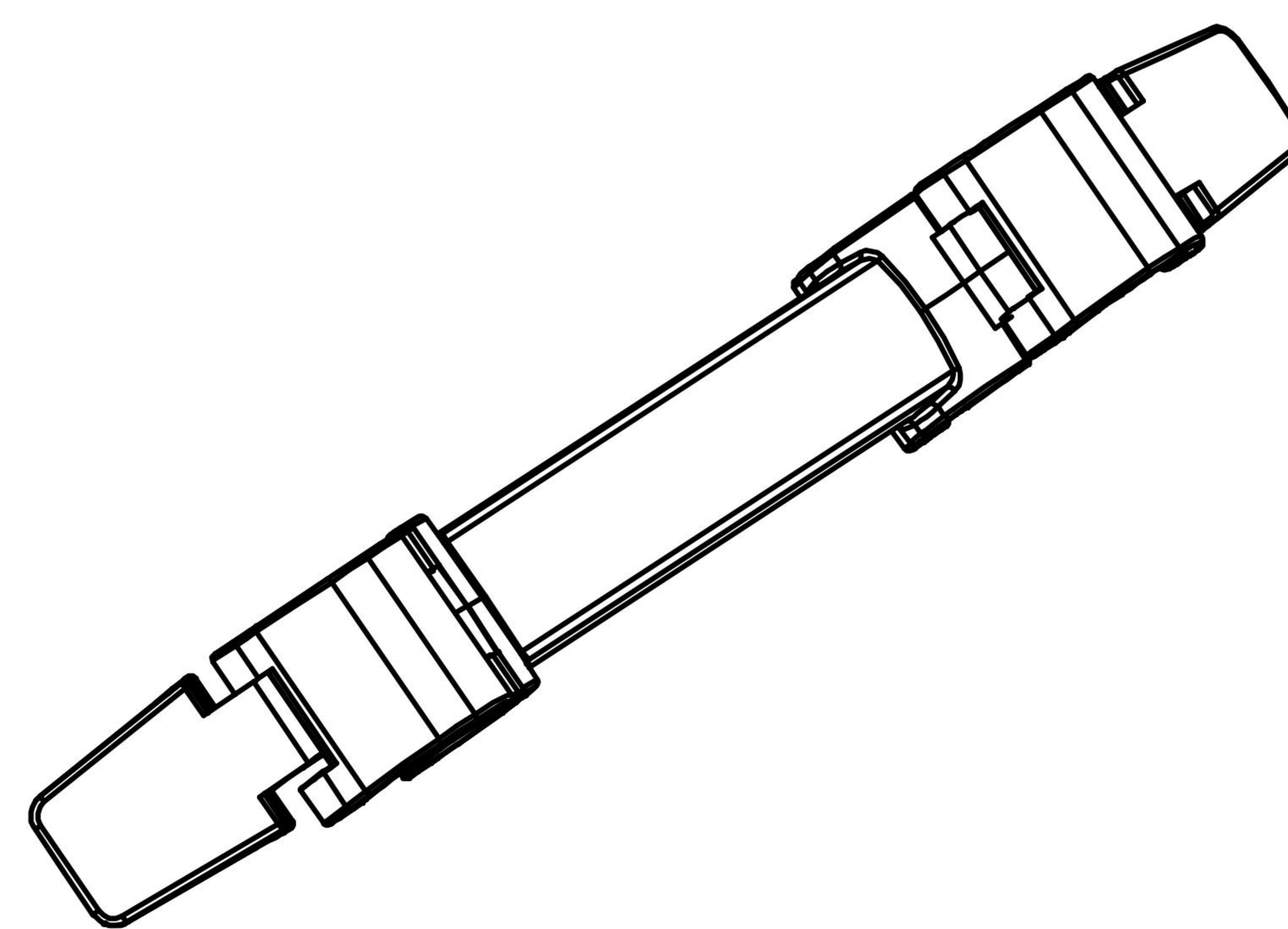

Cx1

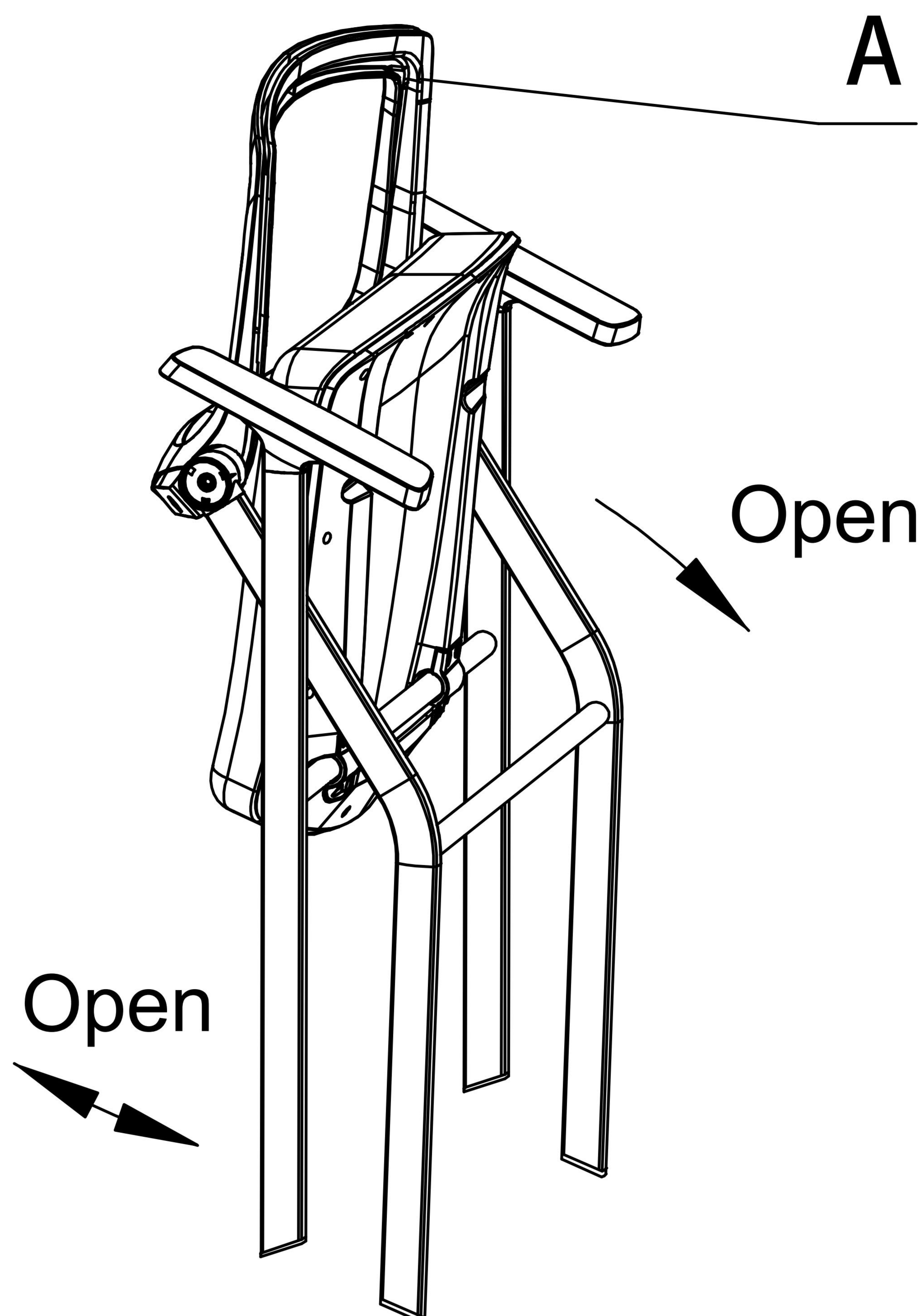

Step 1: Open the Chair **A** as the picture.

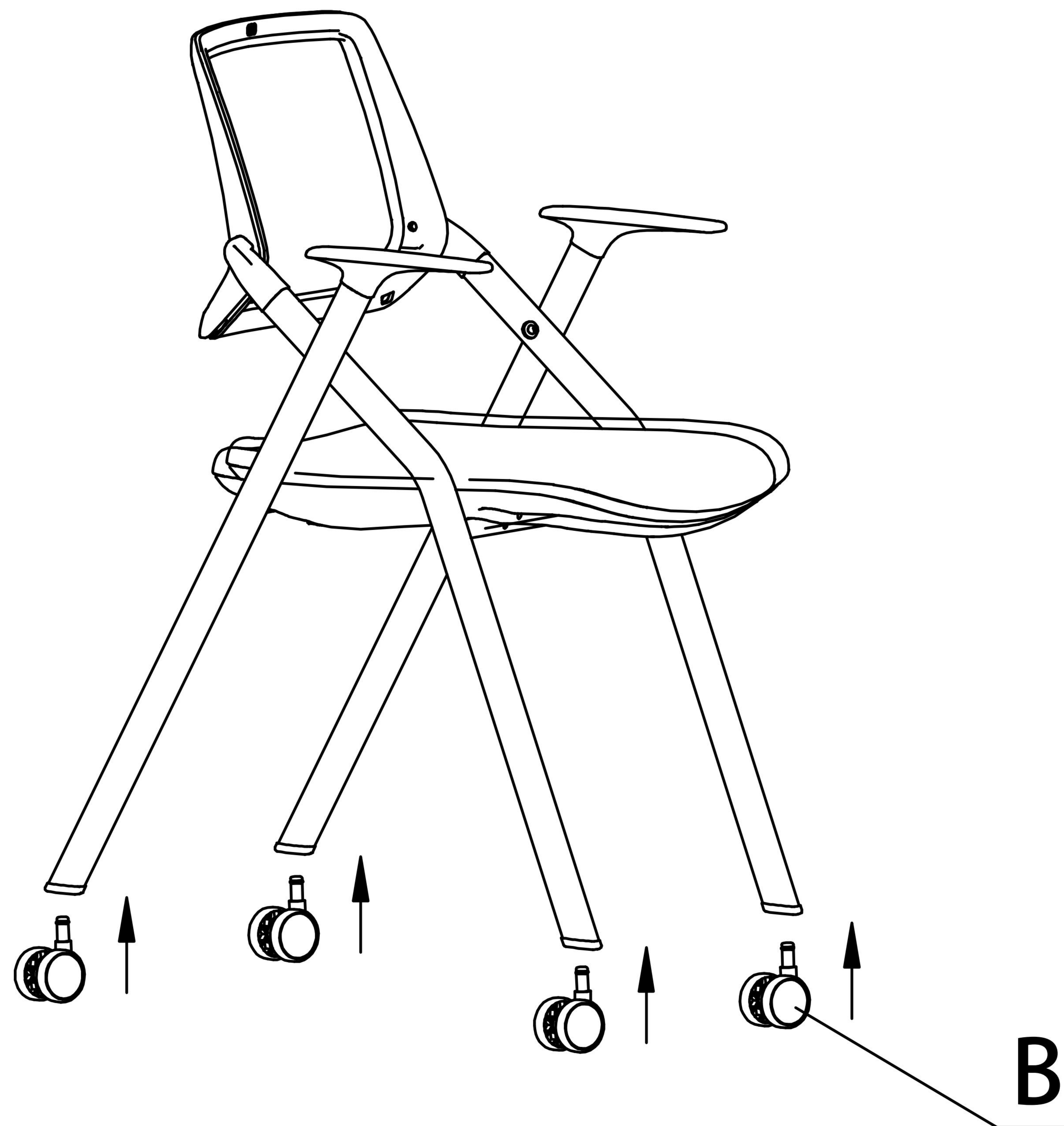

**Step 2:** Insert Casters **Bx8** into the chair with force.

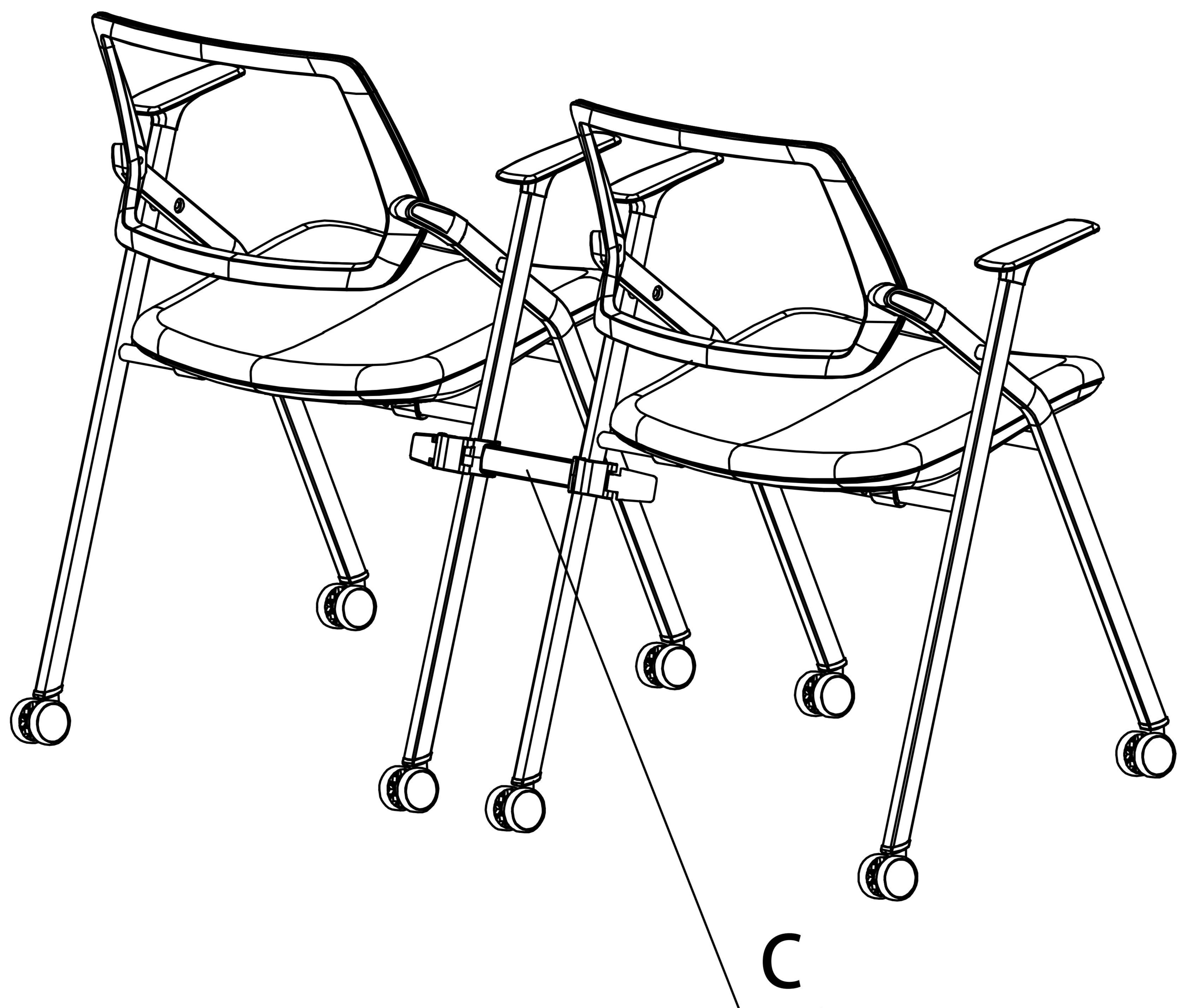

**Step 3(If Needed):** Fasten the Connector **C** as the picture.

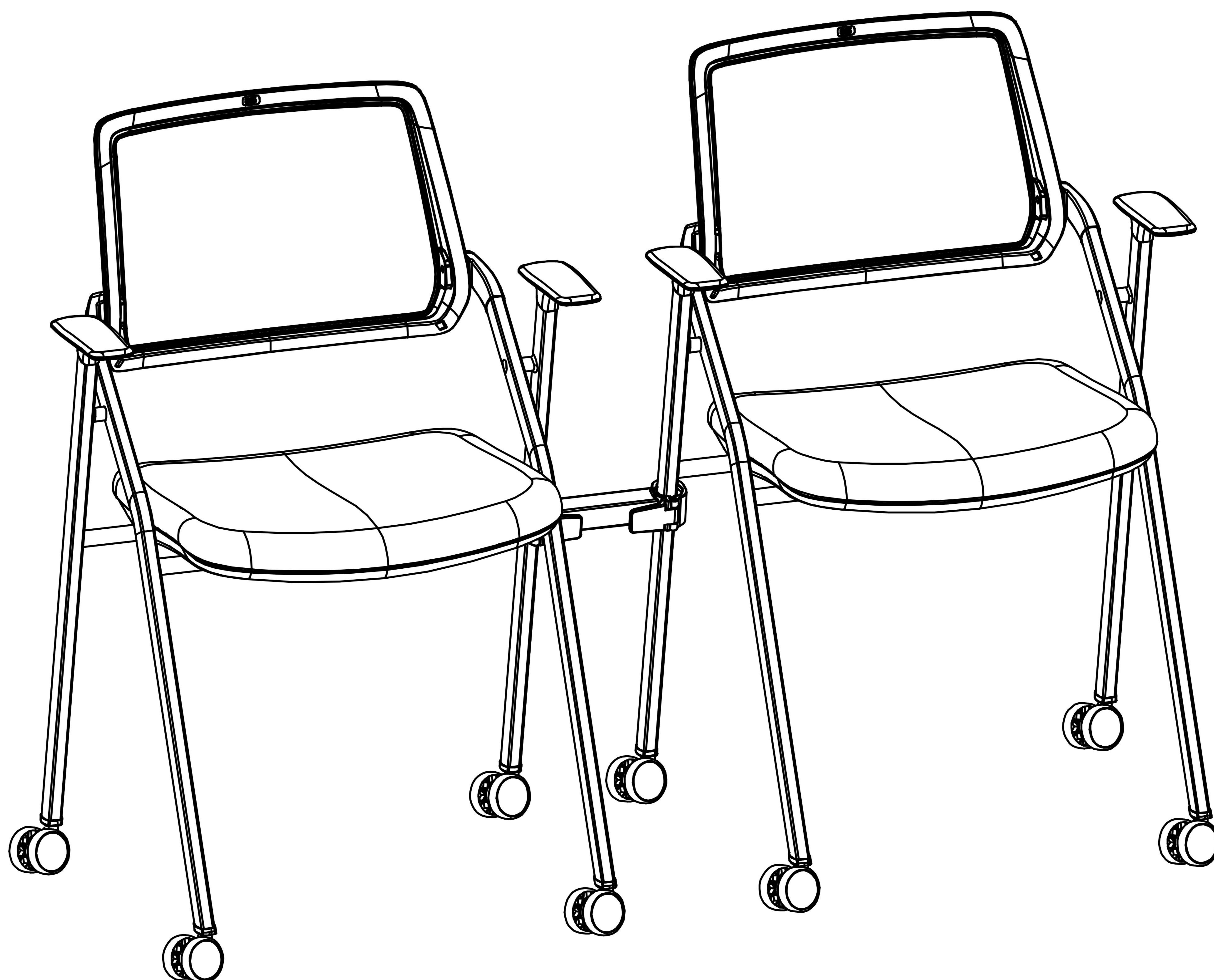

**Step 4:** Enjoy your new chairs!

# THANK YOU

Thank you for choosing our product. We sincerely hope that the assembly process has been smooth and enjoyable for you. If you have any questions or suggestions during the use of the product, please feel free to contact us.

