

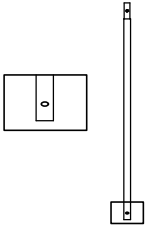

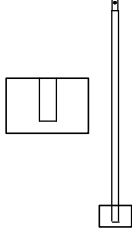







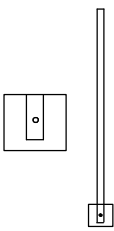









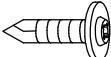

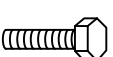
Ax11  $\phi 25 \times 0.6 \times \frac{1050}{41.3}$		Bx4  $\phi 25 \times 0.6 \times \frac{1050}{41.3}$		Cx11  $\phi 25 \times 0.6 \times \frac{900}{35.4}$		Dx4  $\phi 25 \times 0.6 \times \frac{1000}{39.4}$		Ex4  $\phi 25 \times 0.6 \times \frac{1000}{39.4}$		Fx3  $\phi 25 \times 0.6 \times \frac{520}{20.5}$		
G1x18 	G2x18 	H1x2 		H2x2 		H3x2 		I1x2 		I2x2 		
Jx30 		Kx4  $M10 \times \frac{40}{1.6}$		Lx18  $M6 \times \frac{40}{1.6}$		Mx37  $M6 \times \frac{30}{1.2}$		Nx59 		N1x6 		 
Ox1 		Px1 		Q1x2  M6		Q2x1  M10		Rx6 				

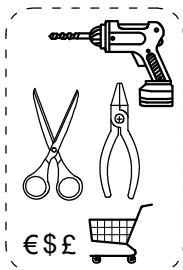
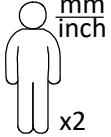

2 x 2 x 2 m (L x W x H)

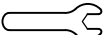
① x4

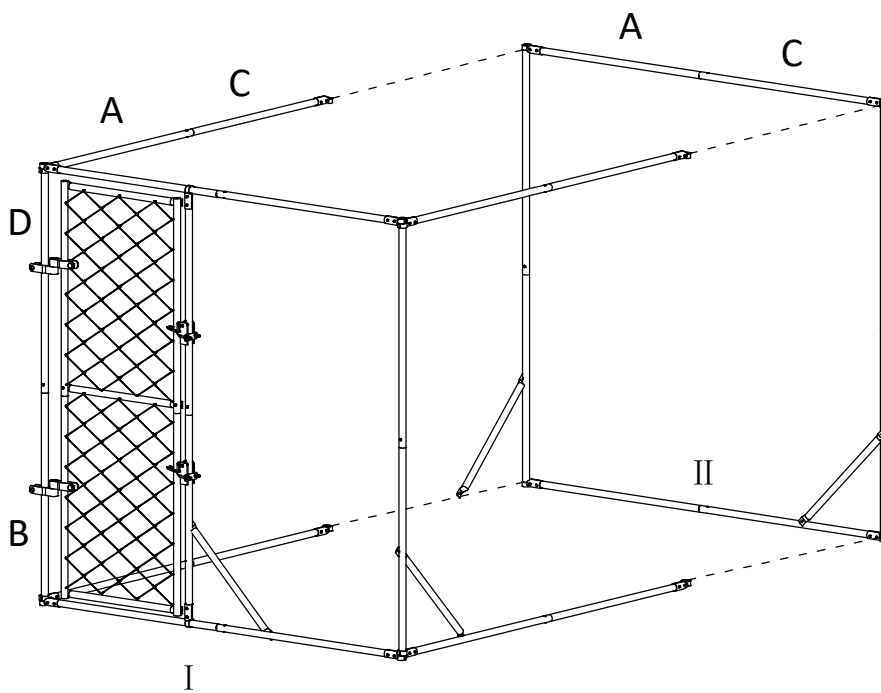
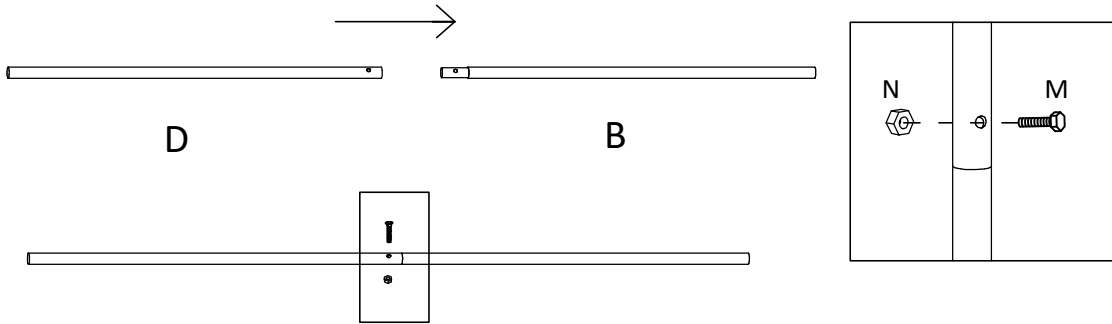

Nx4	
Mx4	

② x4

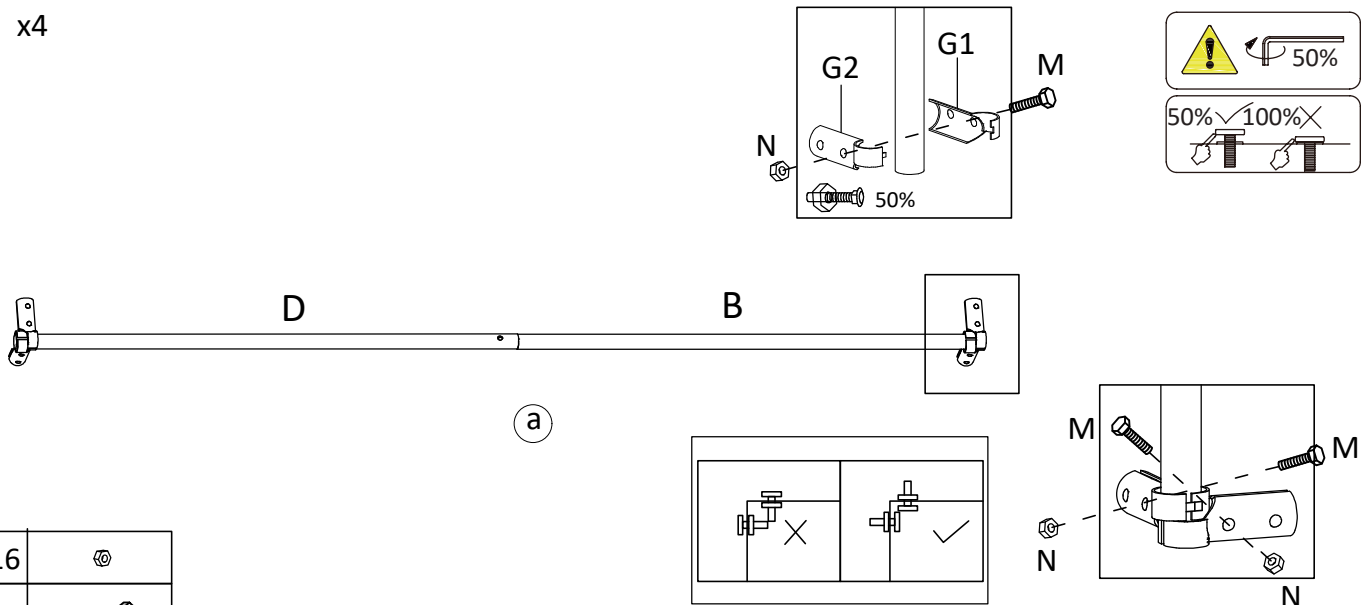

Nx16	
Mx16	

③ x9

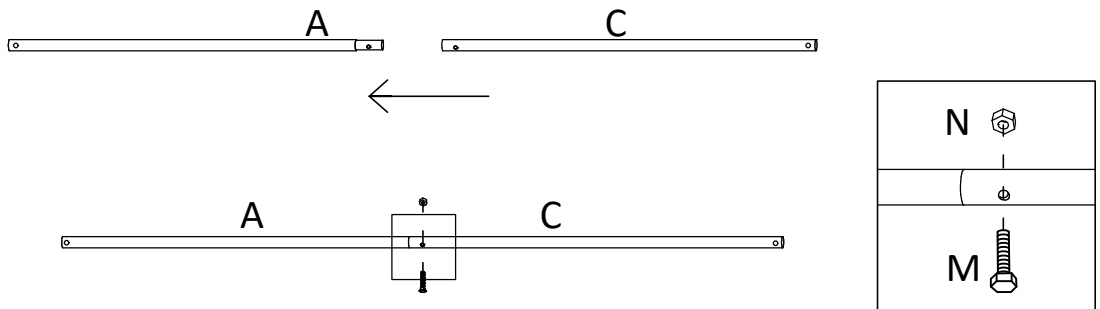

Nx10	
Mx10	

4

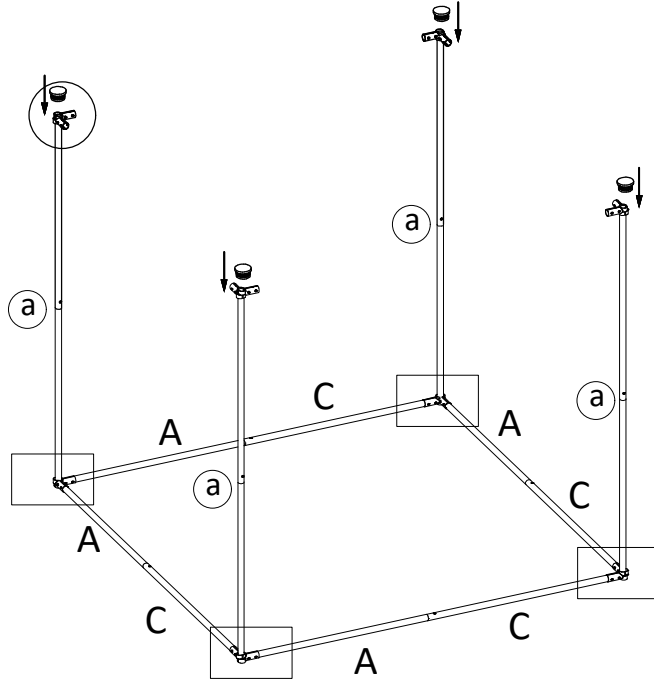
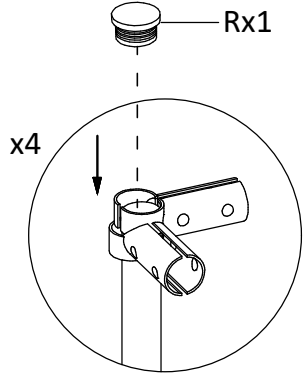
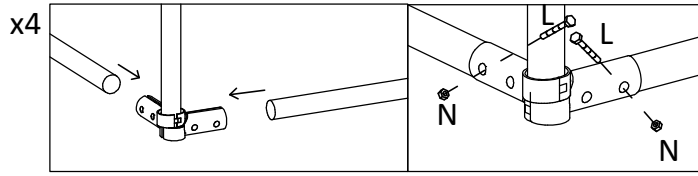

Nx8	
Lx8	

5

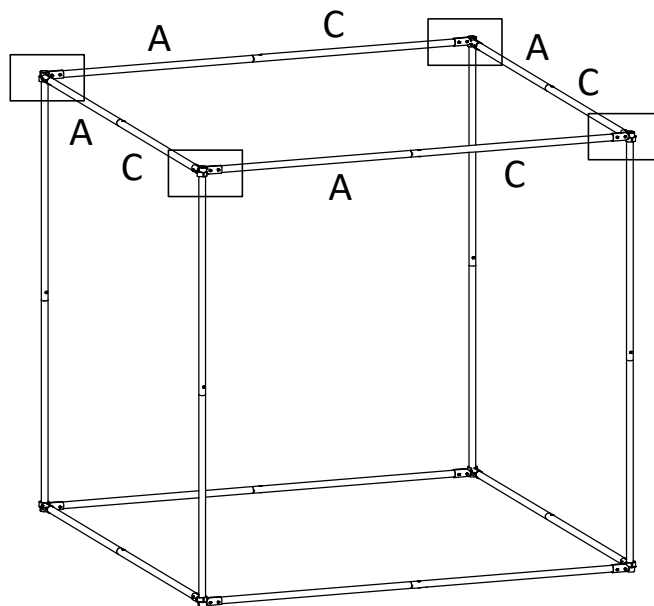
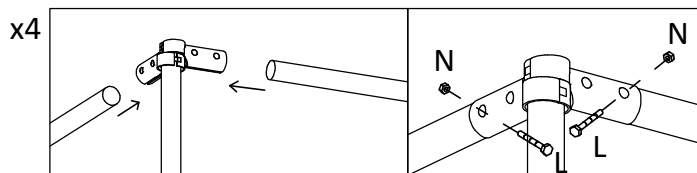

Nx8	
Lx8	

6

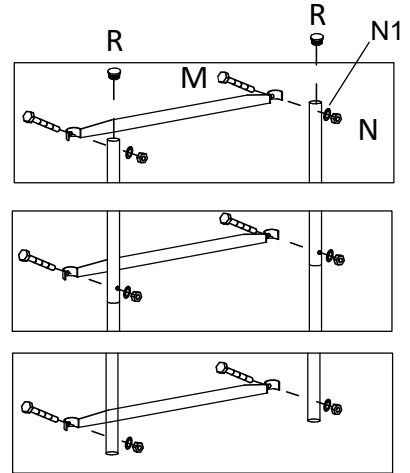
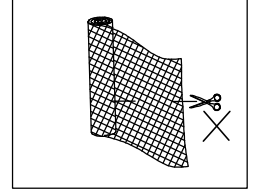
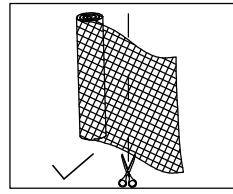
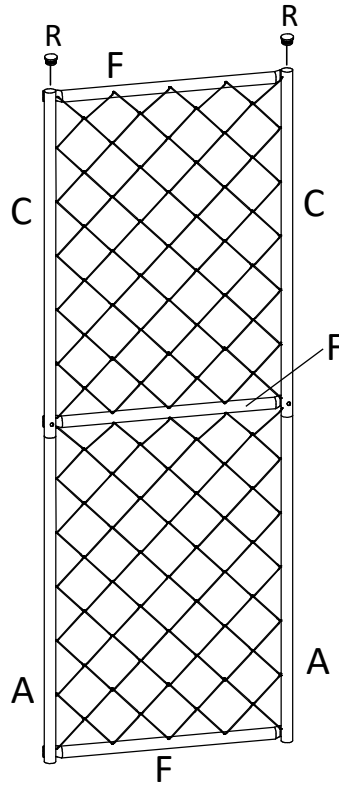
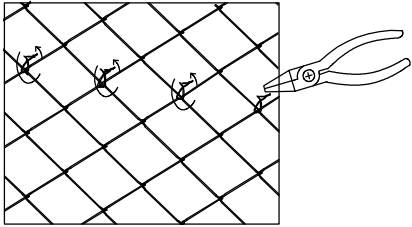
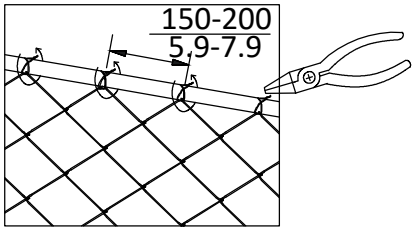
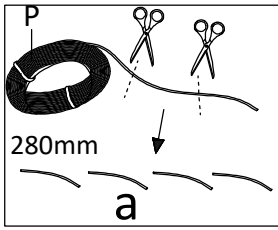

N1x6	
Nx6	
Mx6	

7

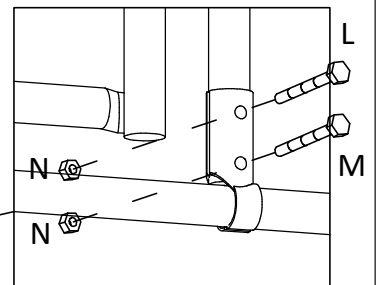
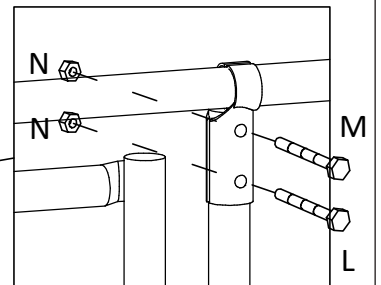
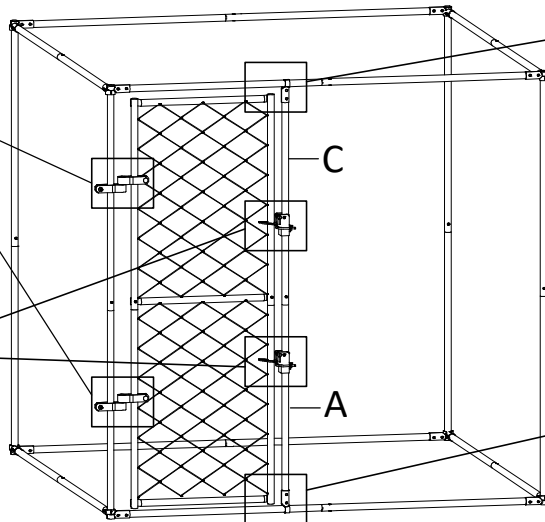
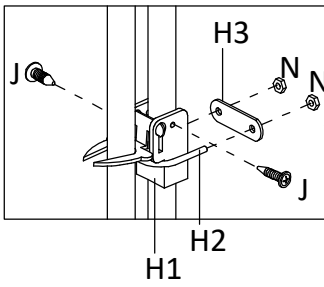
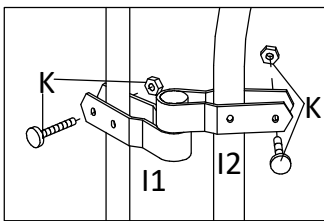

Mx2		Jx4	
Lx2		Kx4	
		Nx8	

8



All the screws

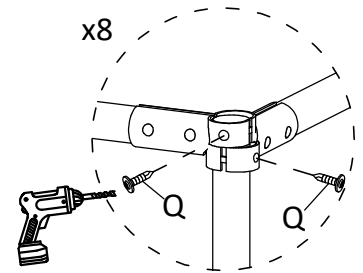
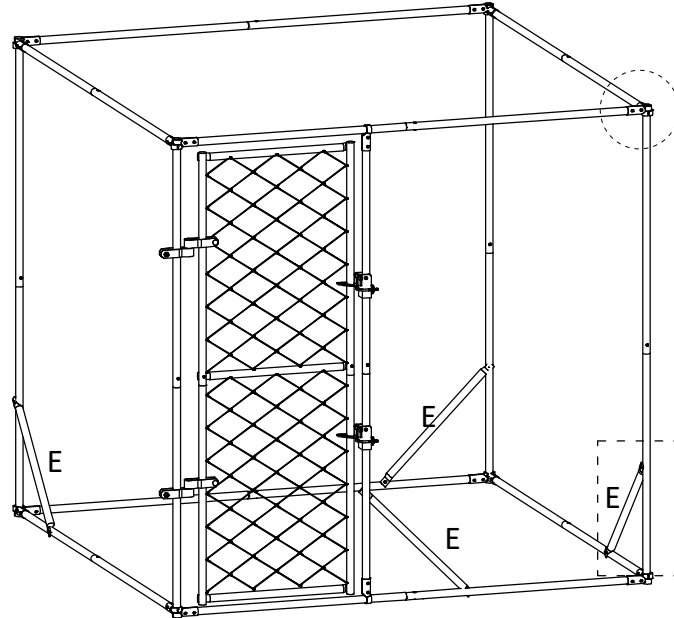
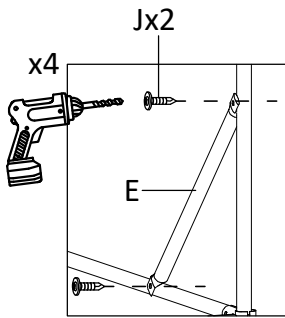

Jx26





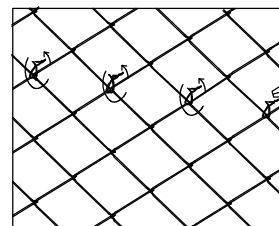
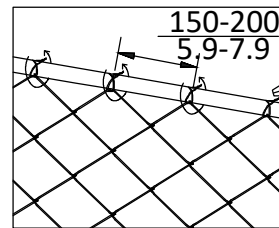
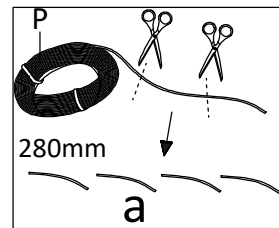
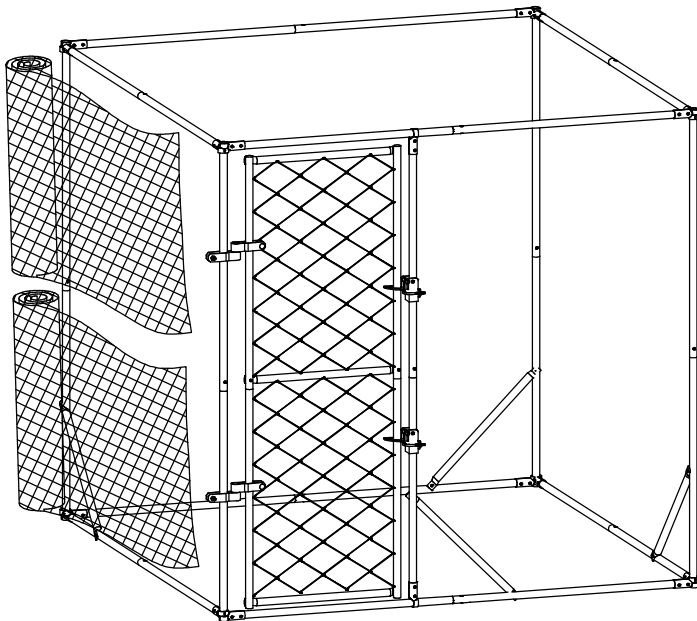



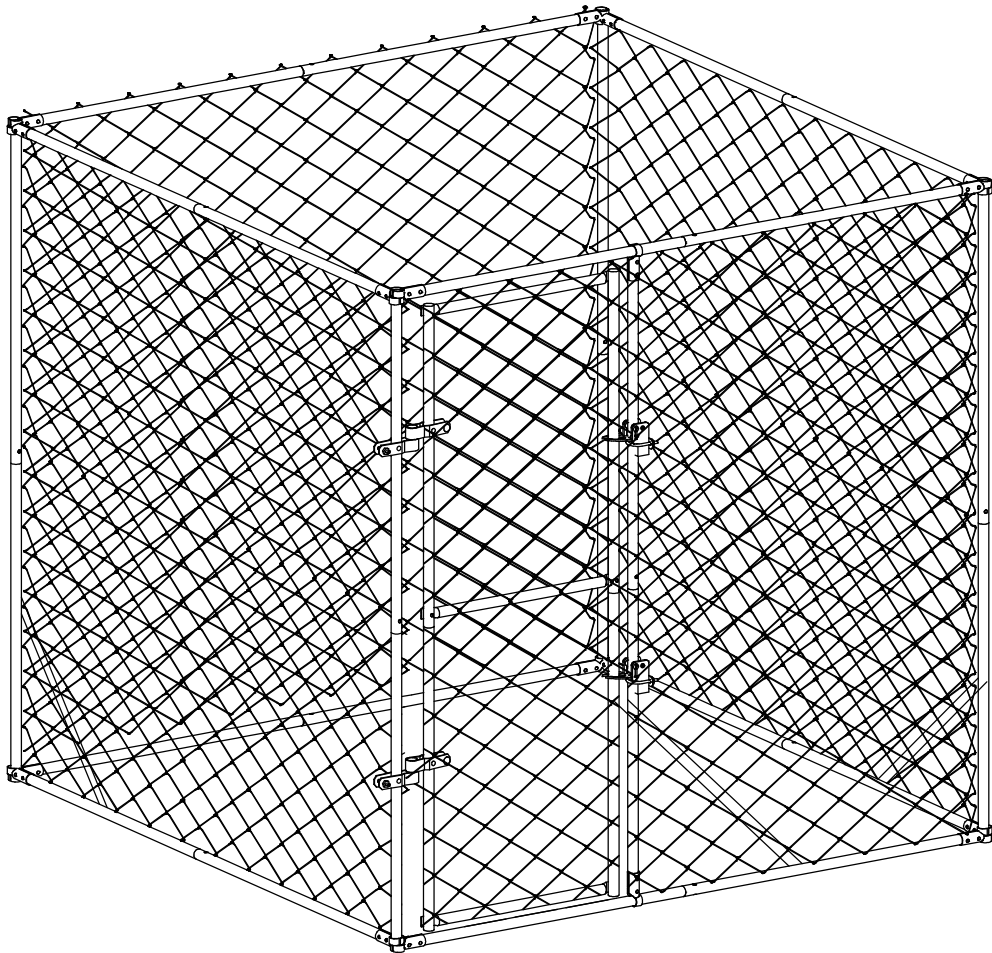

9

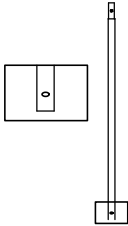
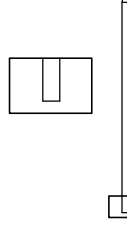

10

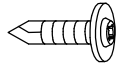
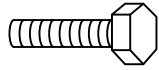
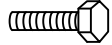

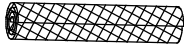
2 x 2 x 2 m (L x W x H)

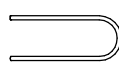
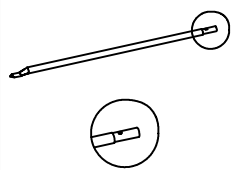
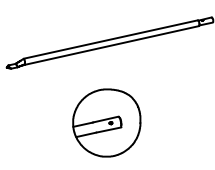
<p>Ax8</p>  <p>$\phi 25 \times 0.6 \times \frac{1050}{41.3}$</p>	<p>Bx4</p>  <p>$\phi 25 \times 0.6 \times \frac{1050}{41.3}$</p>	<p>Zx8</p>  <p>$\phi 25 \times 0.6 \times \frac{930}{36.6}$</p>	<p>Dx4</p>  <p>$\phi 25 \times 0.6 \times \frac{1000}{39.4}$</p>	<p>G1x16</p> 	<p>G2x16</p> 
<p>Jx16</p> 	<p>Lx16</p>  <p>M6x $\frac{40}{1.6}$</p>	<p>Mx32</p>  <p>M6x $\frac{30}{1.2}$</p>	<p>Nx48</p> 	<p>Ox1</p> 	<p>Px1</p> 
<p>Rx4</p> 	<p>Yx4</p> 	<p>X1x4</p>  <p>$\frac{740}{29.1}$</p>	<p>X2x4</p>  <p>$\frac{740}{29.1}$</p>		

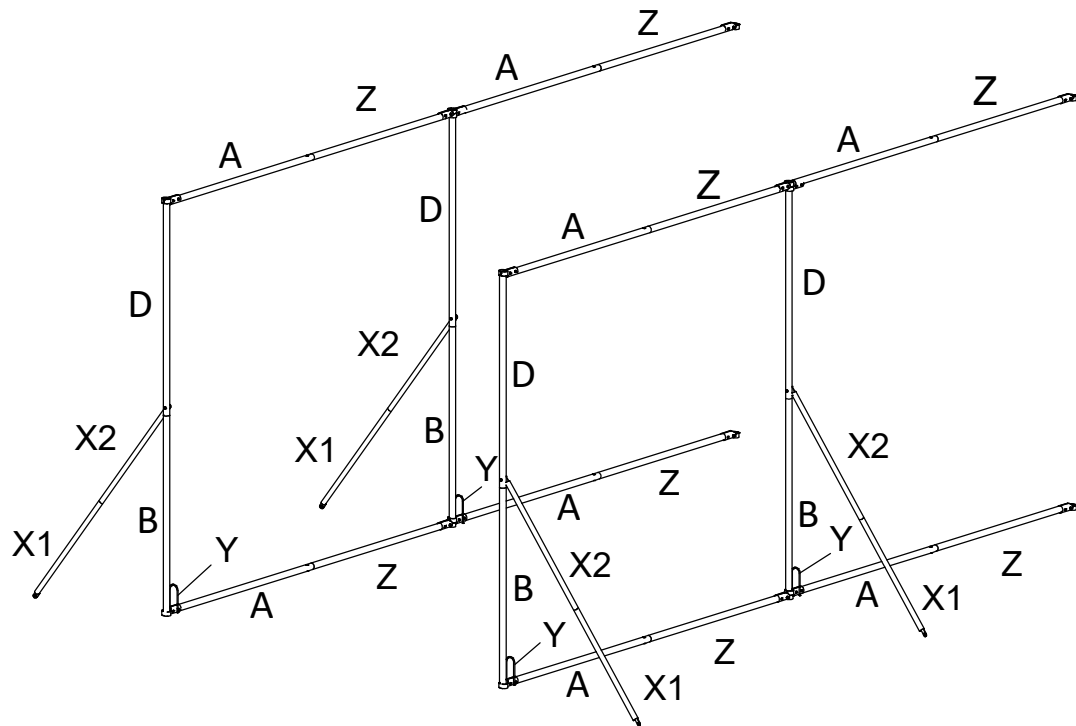

III

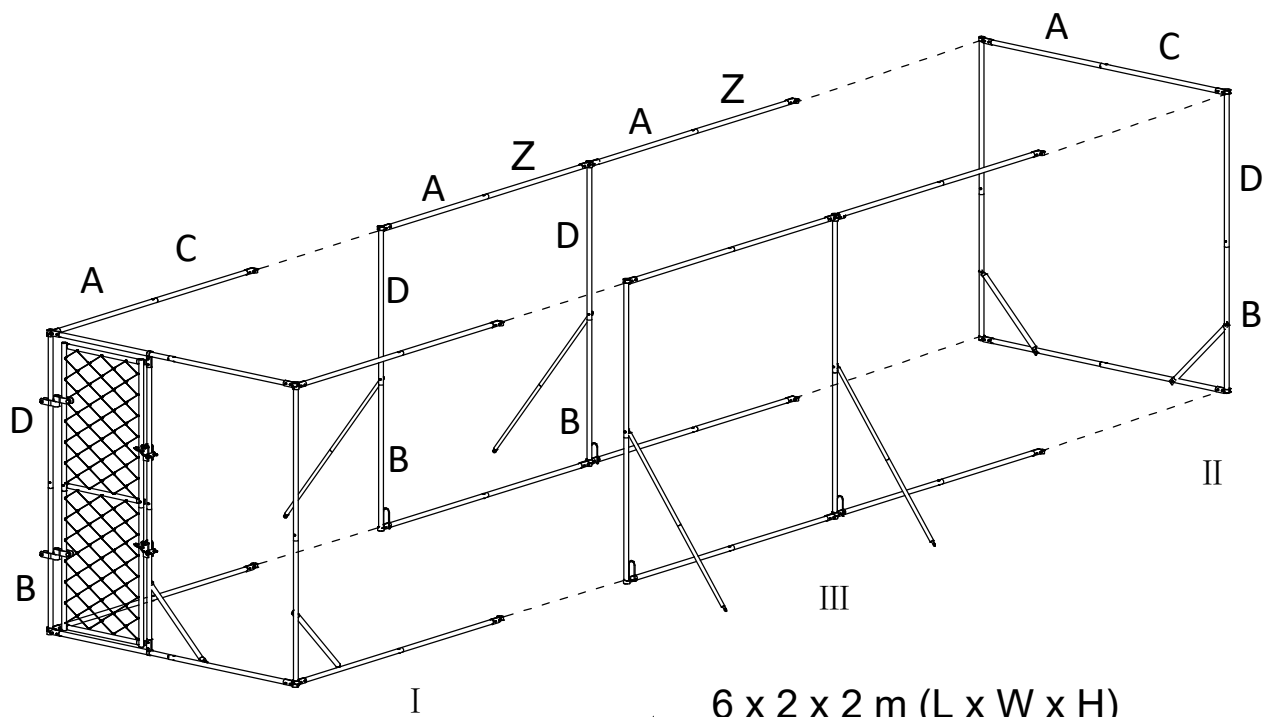

6 x 2 x 2 m (L x W x H)

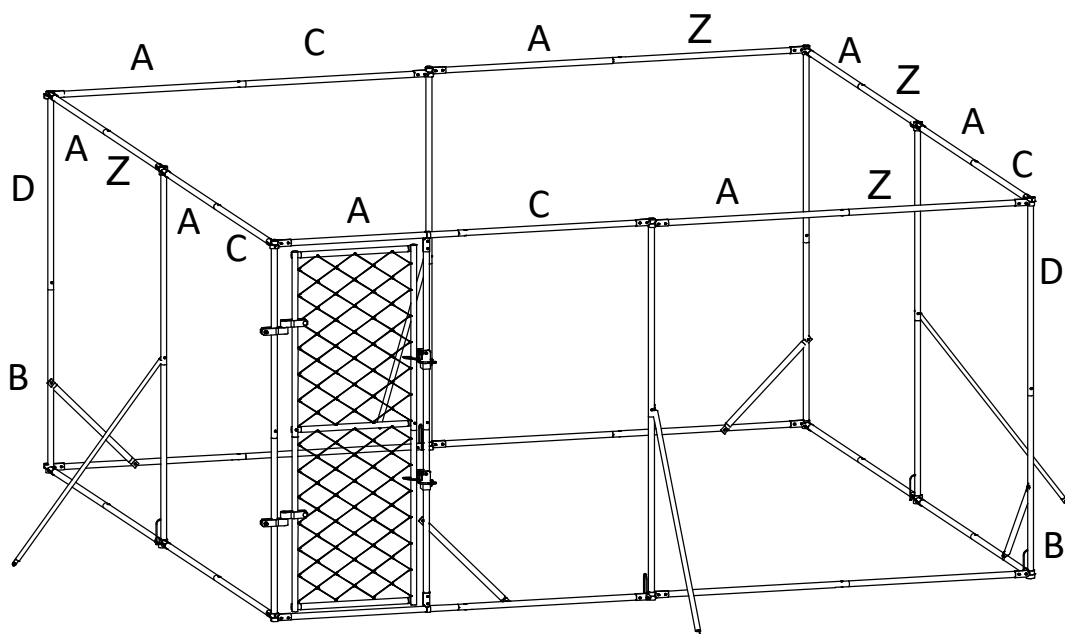

4 x 4 x 2 m (L x W x H)

① x8

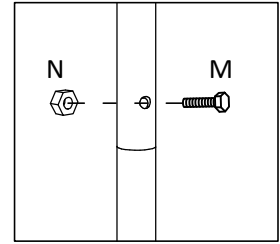
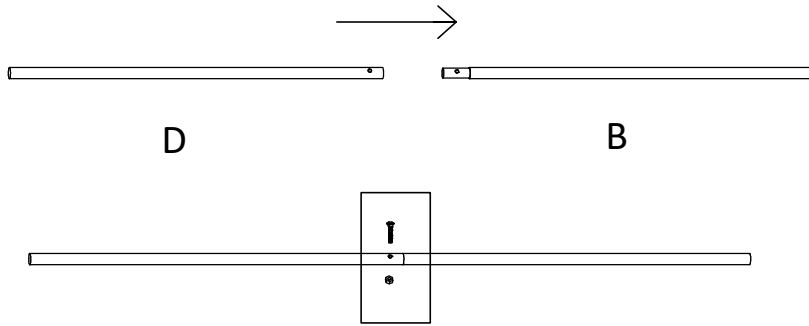

Nx8	
Mx8	

② x8

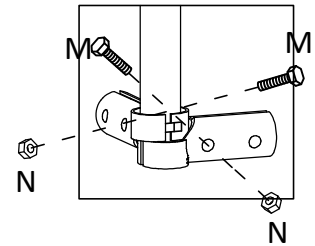
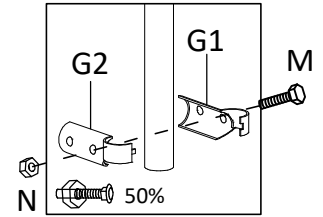
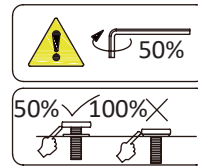
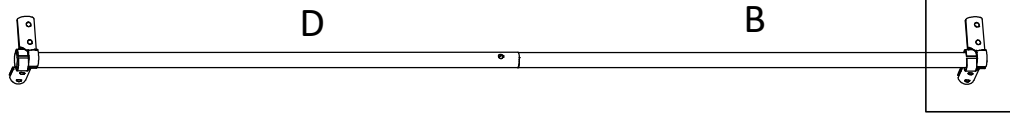

Nx32	
Mx32	

③ x9

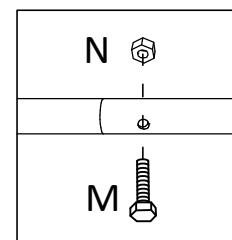
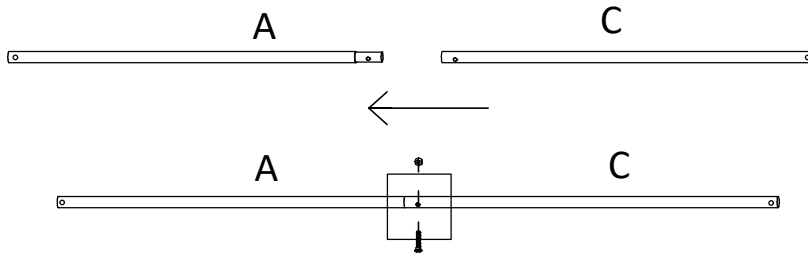

Nx9	
Mx9	

④ x8

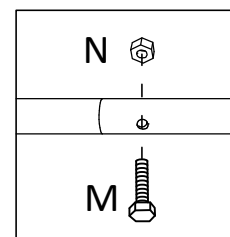
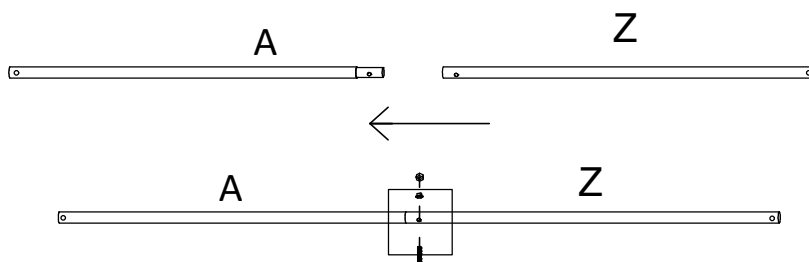

Nx8	
Mx8	

5

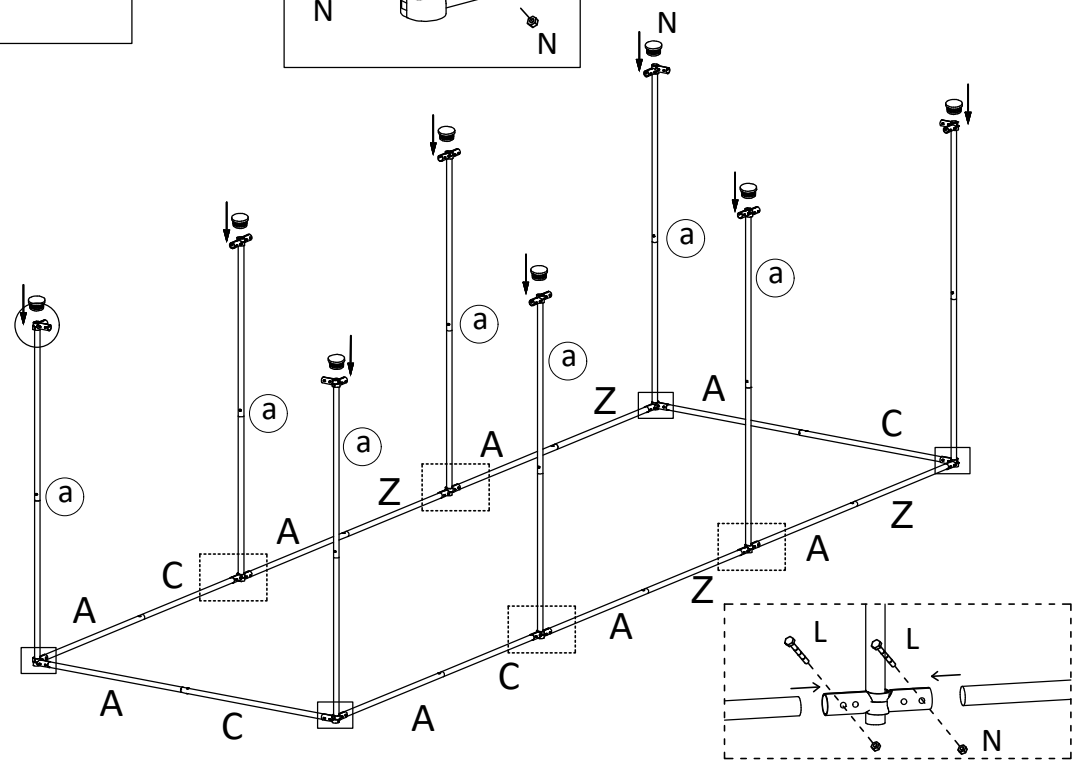
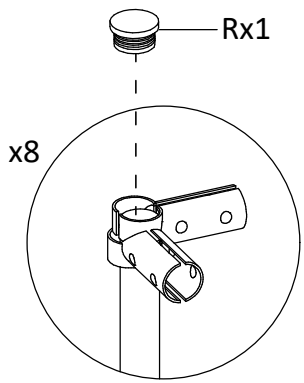
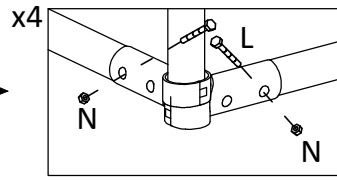
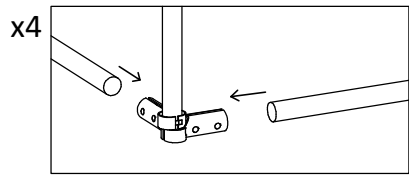

4

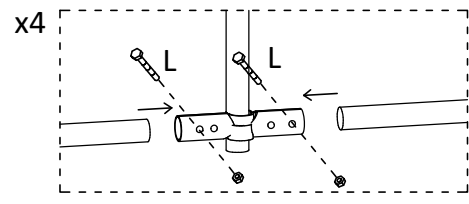
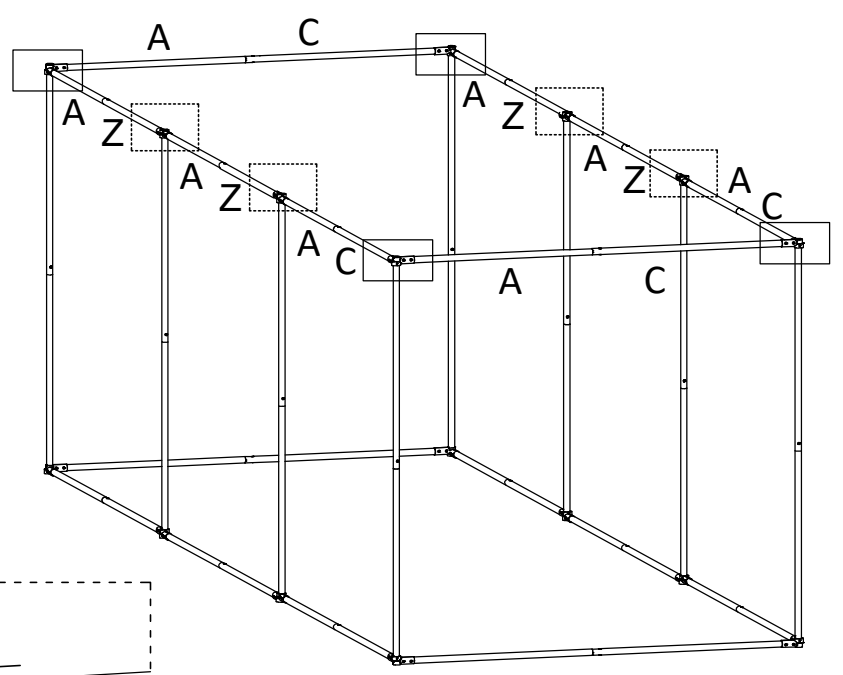
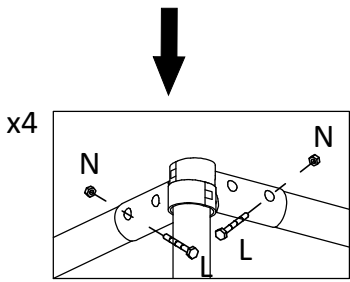
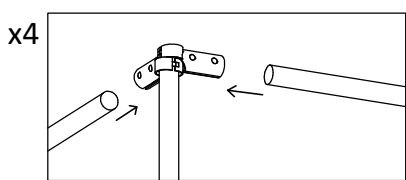

Nx16	
Lx16	

7

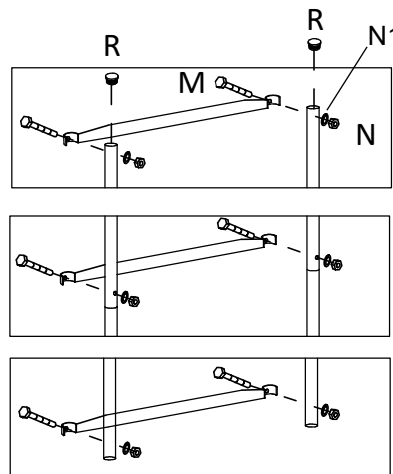
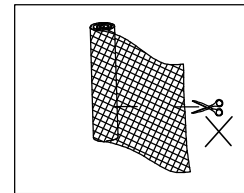
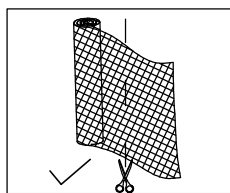
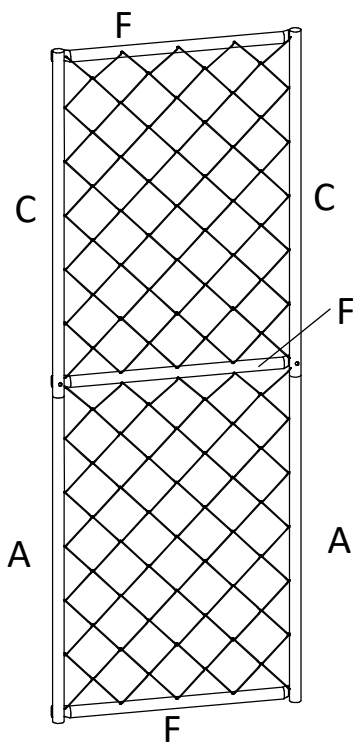
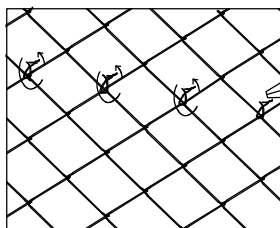
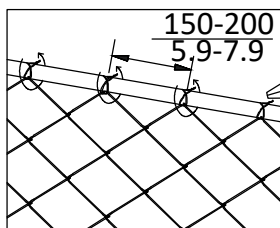
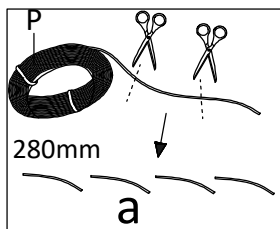

N1x6	
Nx6	
Mx6	

8

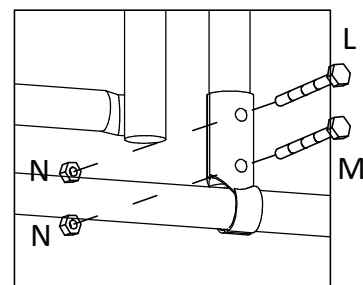
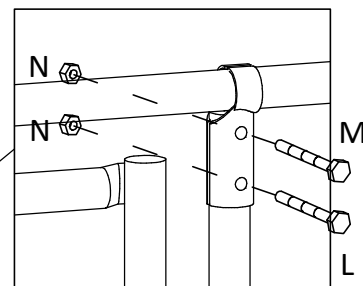
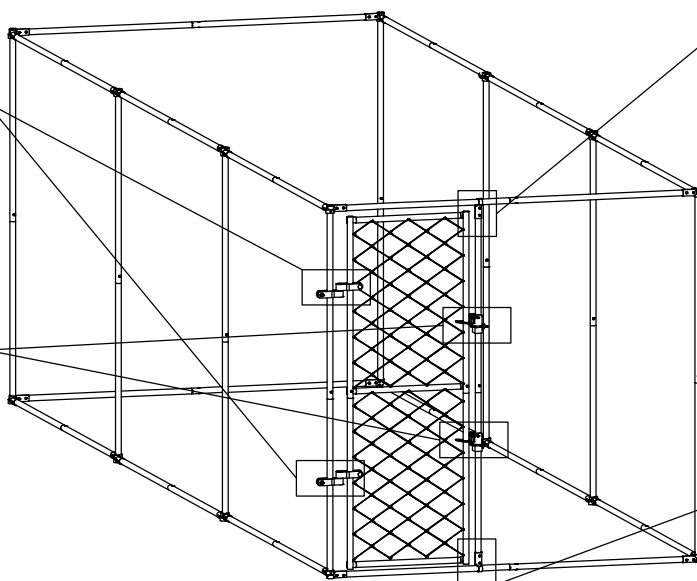
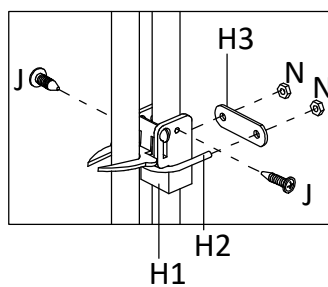
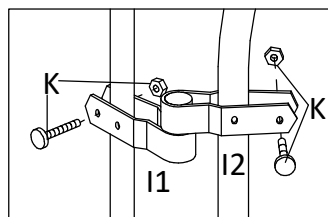

Mx2		Jx4			
Lx2		Kx4		Nx8	

9

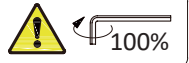

100%

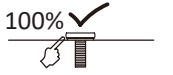

All the screws

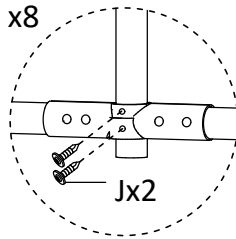
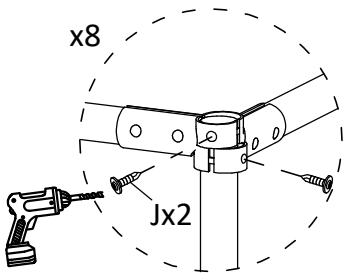
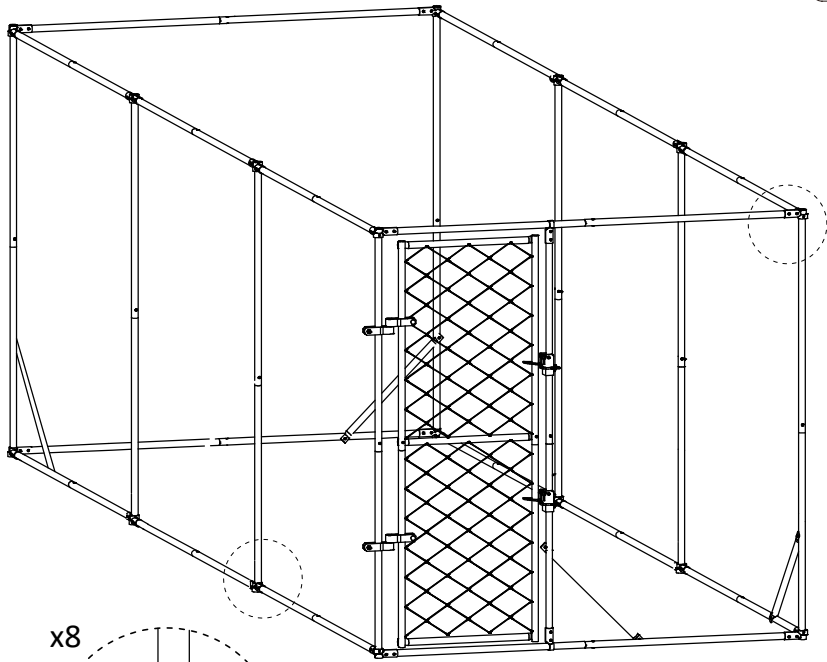
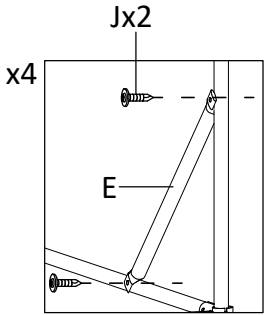

Jx42



10

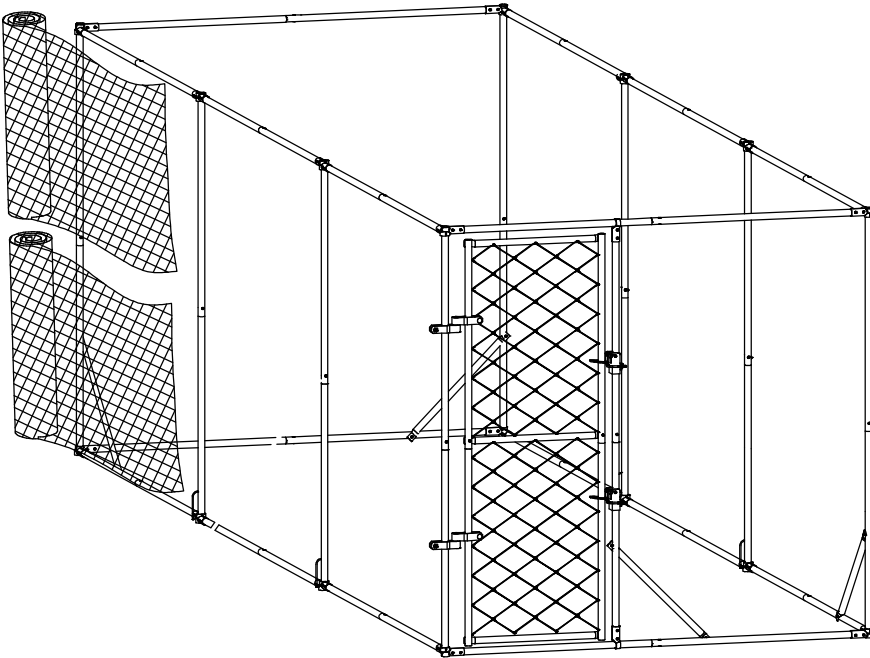
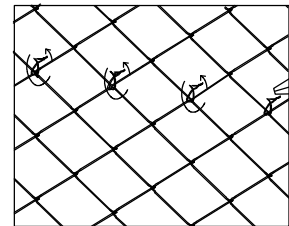
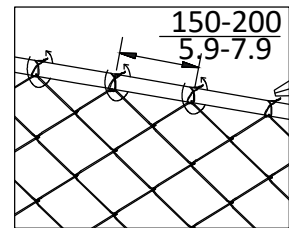
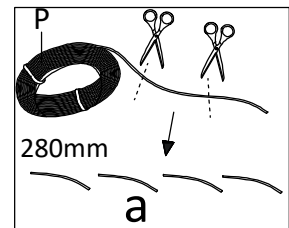

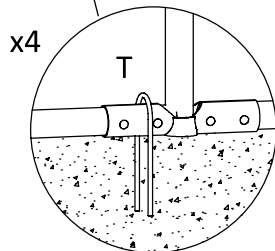
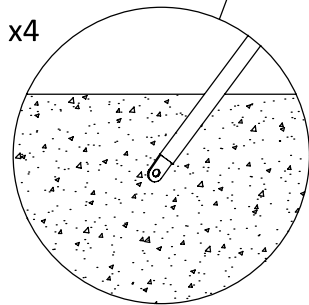
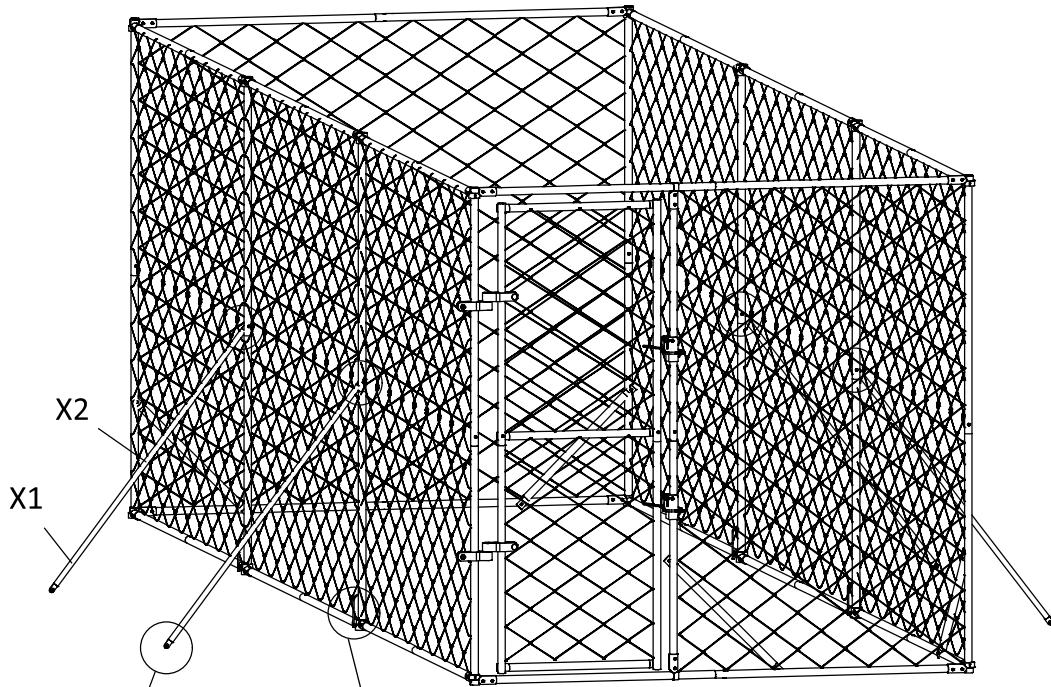
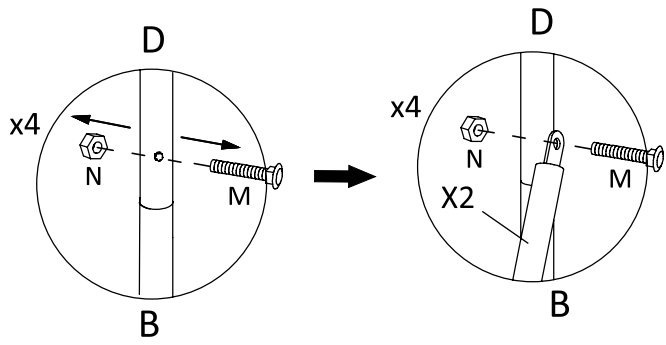
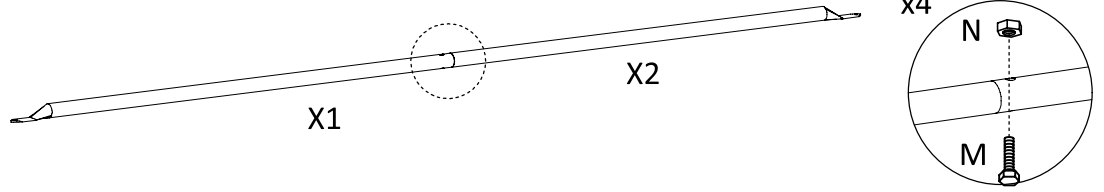

Nx4	
Mx4	

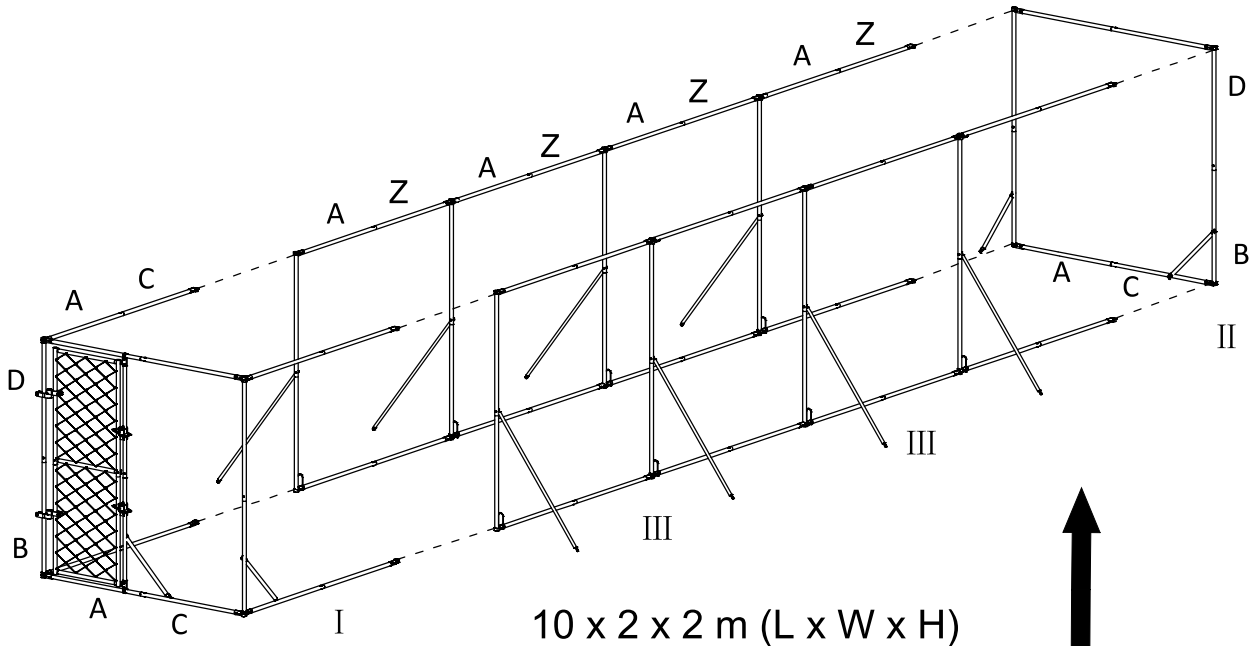

$10 \times 2 \times 2 \text{ m (L x W x H)}$

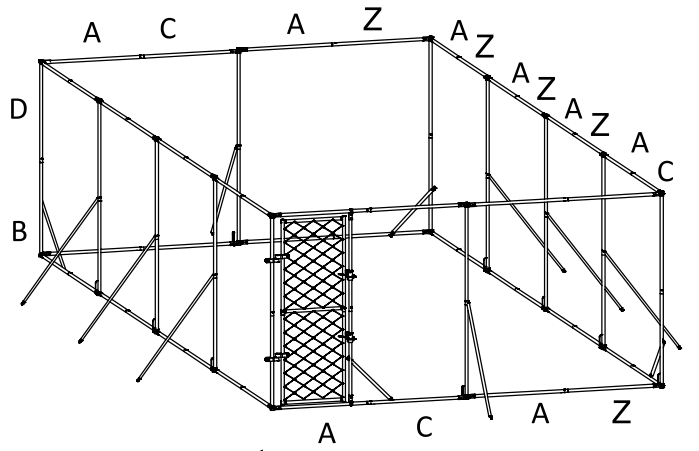

$8 \times 4 \times 2 \text{ m (L x W x H)}$

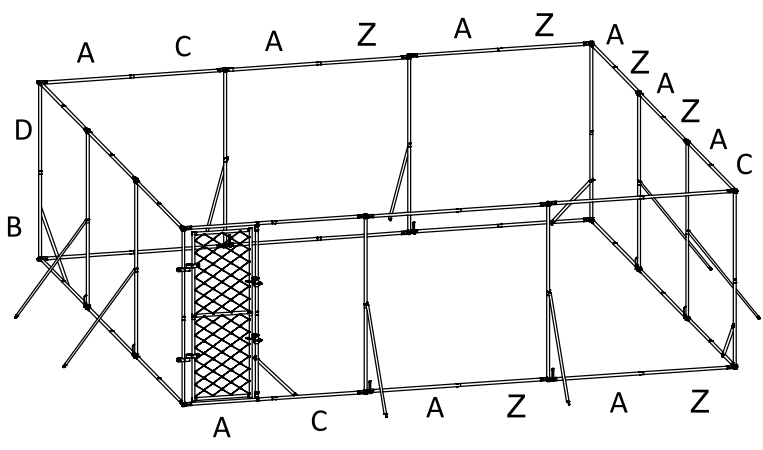
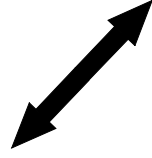

$6 \times 6 \times 2 \text{ m (L x W x H)}$

