

CARE AND MAINTENANCE













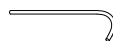



Wipe clean with a soft, dry cloth. Test the cleaning method on a hidden area before using them over the entire area.

NOTICE

- * Please make sure that you have all parts indicated before you begin assembly of this item.
- * This item should be assembled on a soft surface to prevent scratching the finished product during assembly.
- * This item may require periodic tightening.
- * Do not tighten bolts until completely assembled.

Product Dimensions: 61-7/8"Wx82-1/4"Dx59"H

Part List and Hardware List

PIECE	DESCRIPTION	PICTURE	QUANTITY
A	Headboard		1x
B	Footboard		1x
C	Headboard post		2x
D	Footboard post		2x
E	L-Rail		2x
F	R-Rail		2x
G	Connect bar		2x
H	Metal slat		6x
I	Support legs of rails		2x
J	Support legs of slats		6x
H1	Allen Bolt	 1/4"x5/8"	34x
H2	Allen Bolt	 1/4"x1-1/2"	26x
H3	Flat Washer	 $\phi 13 \times 1.0$	8x
H4	Spring Washer	 1/4"	8x
H5	Nut	 1/4"	8x
H6	Wrench	 M10	1x
H7	Allen Key	 M4	1x

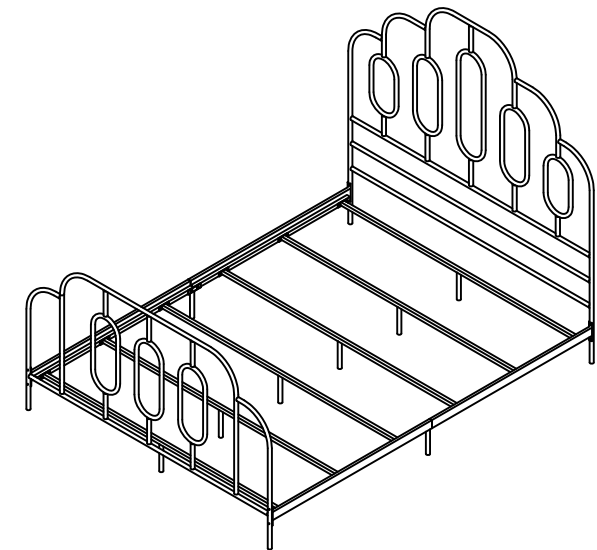

Weight capacity : 550lbs
WARNING : DO NOT STAND ON THE BED

PREPARATION

Before beginning assembly of product, make sure all parts are present. Compare parts with package contents list and hardware contents list. If any part is missing or damaged, do not attempt to assemble the product.

Estimated Assembly Time: 30 minutes.

Tools Required for Assembly (included): Allen Key

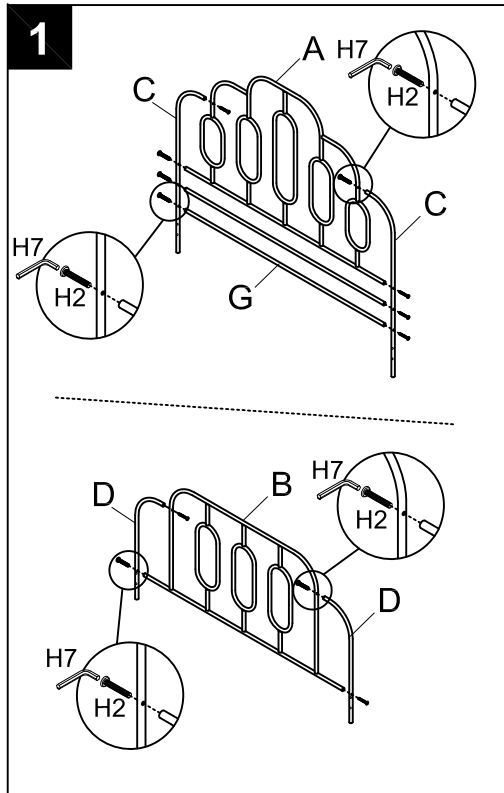

Step 1

Assembly the Headboard : Attach 2*Headboard Post (C) and 2*connect bar (G) to the Headboard (A), Use Allen Key (H7) to lock 8*Allen bolts (H2).

Assembly the Footboard : Attach 2*Footboard Post (D) to the Footboard (B), Use Allen Key (H7) to lock 4*Allen bolts (H2).

Reference image above.

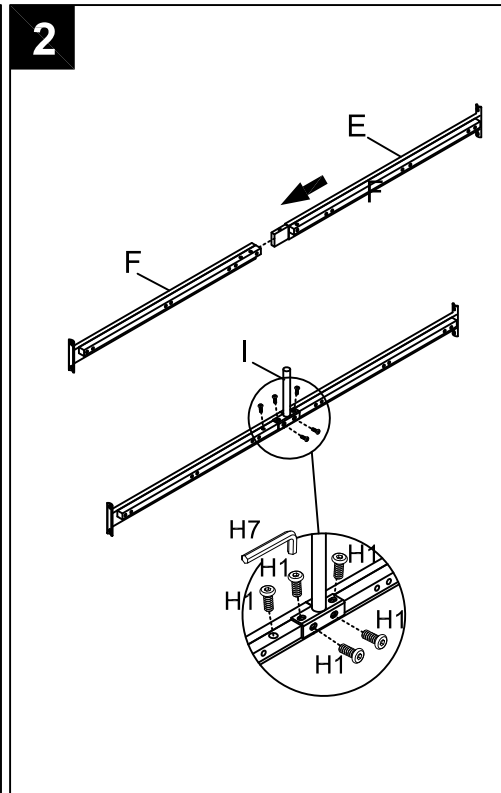

Step 2

Insert L-Rail (E) into the R-Rail (F), then put the Support leg of rail (I) on the alignment position, Using Allen Key (H7) to lock with 5*Allen bolts (H1), Reference image above. (Repeat afore-mentioned to assemble another set of side rail)

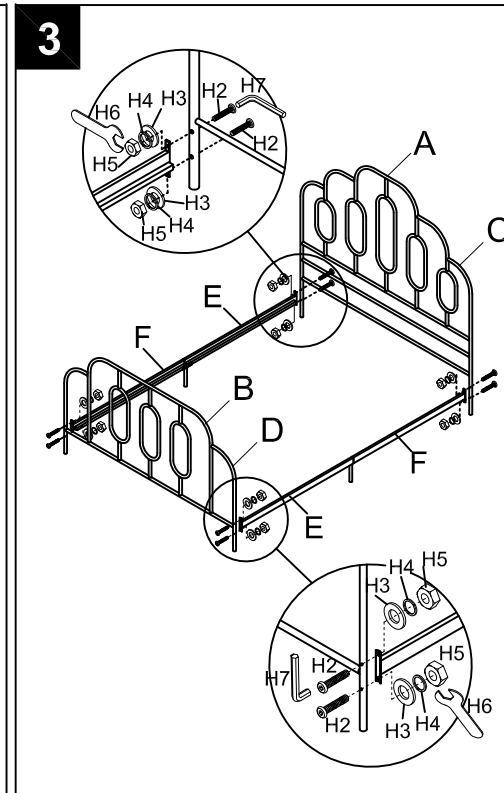

Step 3

Attach the end of assembled 2*side rails to assembled HB/FB posts (C/D), by using Allen Key (H7) to lock 8*Allen bolts (H2). Use Wrench (H6) to lock into assembled HB/FB-posts with Flat washer (H3), Spring washers (H4) and Nut (H5) from the other side.

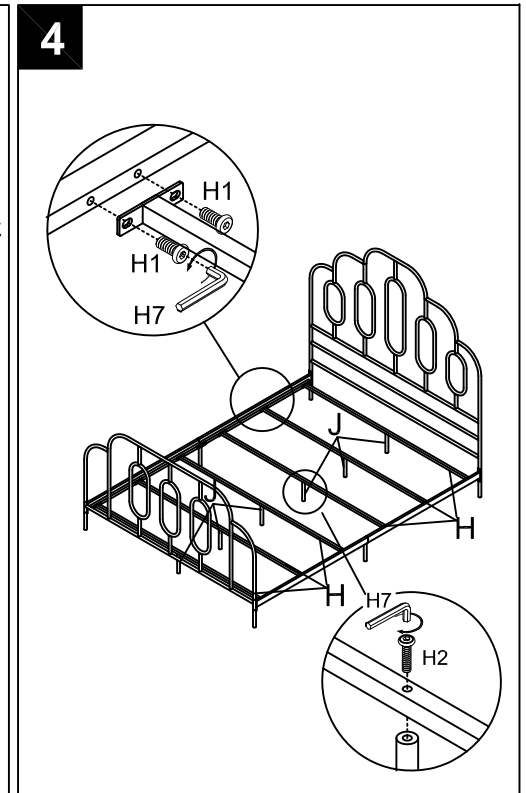

Step 4

Assembly 6*support legs of slats (J) to 6*metal slats (H), by using Allen Key (H7) to lock 6*Allen bolts (H2). Then attach the assembled metal slats (H) on inside of both assembled side rails (E/F), by using Allen Key (H7) to lock 24*Allen bolts (H1). Reference image above. Assembly is completed.