

HEADBOARD & FOOTBOARD

ASSEMBLY INSTRUCTIONS

Before assembling your headboard and footboard, please read through these instructions carefully and familiarize yourself with the different parts.



PARTS LIST

- 1 HEADBOARD PANEL BOARDS 4 PCS
- 2 LEFT LEG 1 PC
- 3 RIGHT LEG 1 PC
- 4 HEADBOARD SUPPORT 1 PC
- 5 FOOTBOARD PANEL BOARDS 3 PCS
- 6 LEFT FOOTBOARD LEG 1 PC
- 7 RIGHT FOOTBOARD LEG 1 PC
- 8 FOOTBOARD SUPPORT 1 PC

Instructions apply for bed sizes
FULL > QUEEN

HARDWARE

- (A) JCB M6 X 35mm - 28 pcs
Spare - 1 pc
- (B) JCB M8 X 15mm (5/8") - 8 pcs
- (C) Wood screw (1 1/4") - 7 pcs
Spare - 1pc
- (D) Allen wrench M4 - 1pc
Spare - 1pc
- (E) Allen wrench M6 - 1pc

NOTE: WE INCLUDE SPARE HARDWARE IN CASE DAMAGE OCCURS DURING ASSEMBLY.

Step 1

Attach left leg (2) and right leg (3) to headboard panel boards (1) using JCB M6 X 35mm (A). Tighten with the Allen wrench M4 (D).

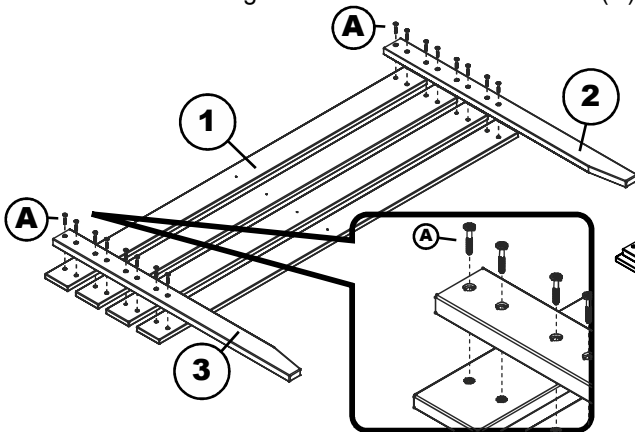

Step 2

Attach headboard support (4) to headboard panel boards using wood screw 1 1/4" (C). Tighten with the Phillips head screw driver. (Customer supplied)

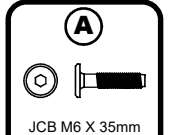
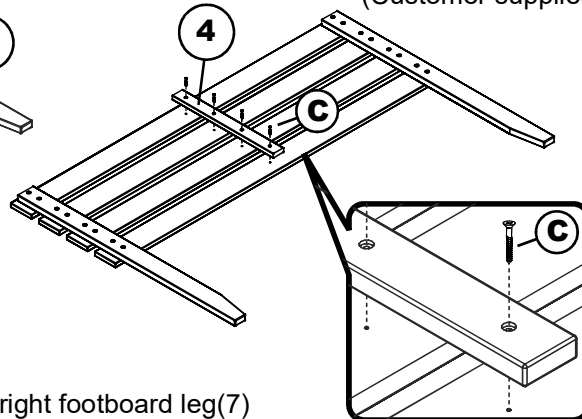

Step 3

Attach left footboard leg (6) and right footboard leg (7) to footboard panel boards (5) using JCB M6 X 35mm (A). Tighten with the Allen wrench M4 (D).

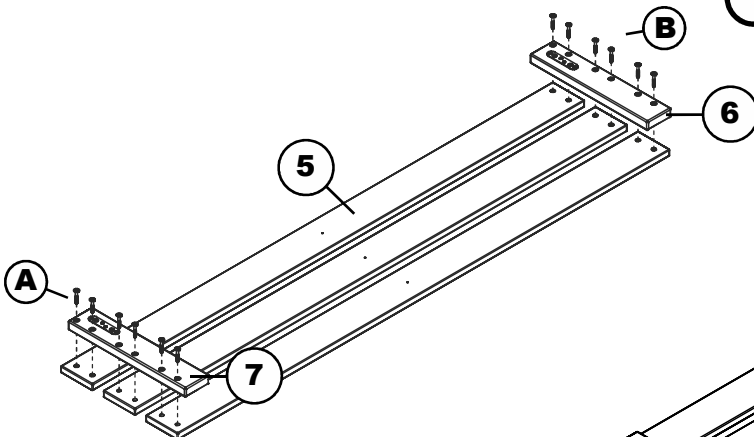

Step 4

Attach footboard support (8) to footboard panel boards using wood screw 1 1/4" (C). Tighten with the Phillips head screwdriver. (Customer supplied)

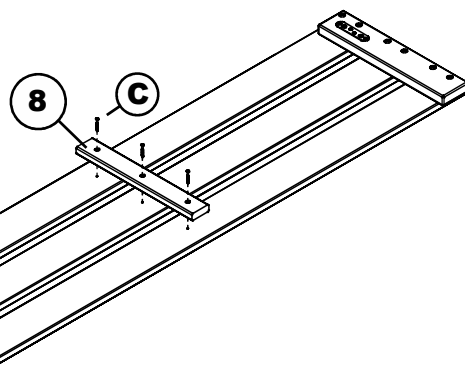

HEADBOARD & FOOTBOARD

FULL > QUEEN

- 01 HARDWARE
 - 02 HEADBOARD
 - 03 FOOTBOARD
- BOX 1

- 01 HARDWARE
 - 04 SIDE RAILS
 - 05 SLAT KIT
- BOX 2



Step 1

Attach the side rails (04) to the headboard (02) and footboard (03) using JCB M8 X 15mm (B). Tighten with Allen wrench M6 (E).

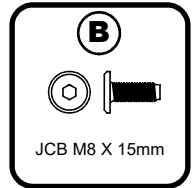
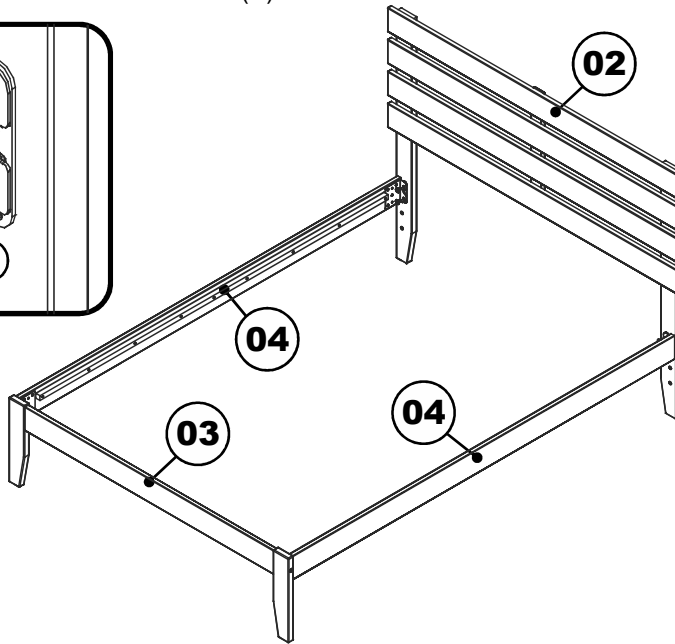
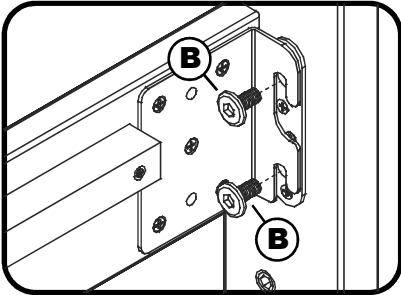

Step 2

Attach slat kit (05) onto the bed using wood screws. Tighten with Phillips head screw driver. (customer supplied) For assembly of slat kit, follow the assembly instructions included with slat kit.

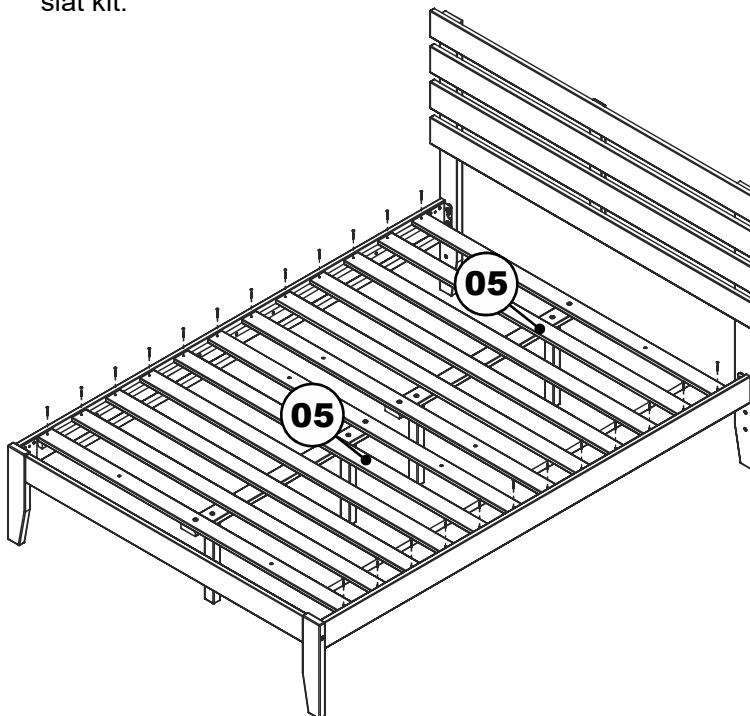

Congratulations!

Your bed is now ready for use.

We recommend that you periodically recheck that all screws are tight to ensure lasting safety.

BED DRAWER SET OF 2

TWIN/FULL ASSEMBLY INSTRUCTIONS

Before assembling your bed drawer, please read through these instructions carefully, familiarize yourself with the different parts.

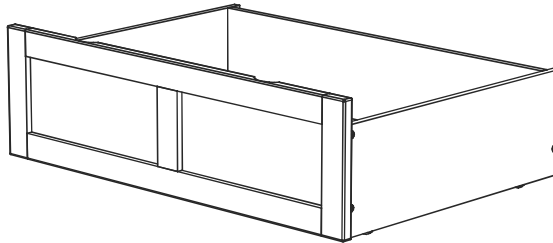
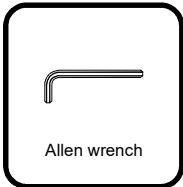

NOTE: WE INCLUDE SPARE HARDWARE IN CASE DAMAGE OCCURS DURING ASSEMBLY.

HARDWARE



(A) JCB M6 X 1" (25mm) - 16 pcs
Spare - 1 pc



(B) Wood Screw X 1 1/4" (32mm) - 4 pcs
Spare - 1 pc



(C) Allen wrench - 1 pc
Spare - 1 pc

PARTS LIST

- (01) HARDWARE 1 BOX**
- (02) DRAWER FACE 1 PC**
- (03) DRAWER SIDE 2 PCS**
- (04) DRAWER BACK 1 PC**
- (05) DRAWER BOTTOM 2 PCS**
- (06) DRAWER MIDDLE 1 PC**
- (07) DRAWER CENTER SUPPORT 1 PC**

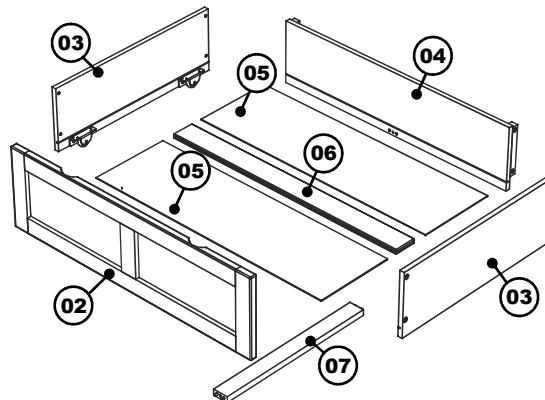

Step 1

Lay the drawer face (02) on smooth, flat surface so the drawer bottom (05) groove is facing upwards. Attach the drawer sides (03) to drawer face (02) using JCB M6 X 1" (A). Align groove inside drawer side with groove in drawer face. Tighten with Allen wrench (C).

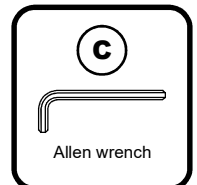
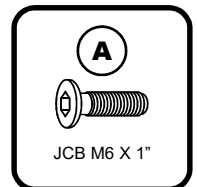
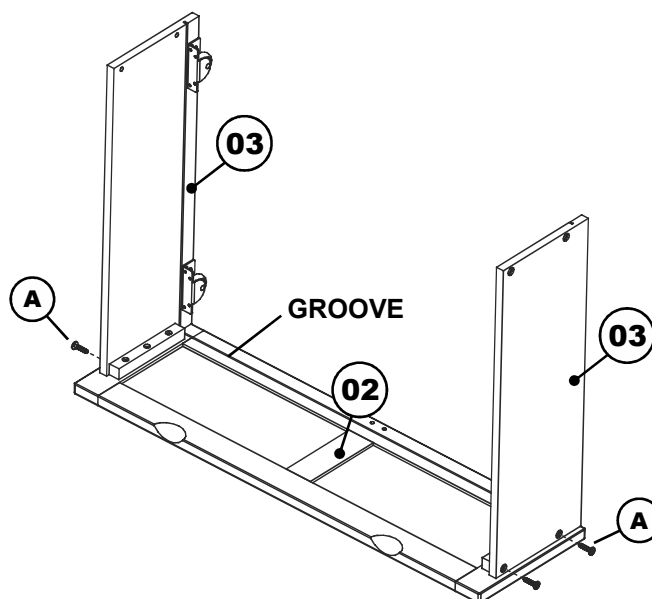

BED DRAWER SET OF 2

TWIN/FULL

Step 2

Guide the drawer bottoms (05) and drawer middle (06) in carefully so that they align inside grooves. Be sure it fits fully into the face and side groove before attaching the drawer back (04).

Attach drawer center support (07) to bottom of drawer face using wood screw 1 1/4" (B). Tighten with Phillips head screw driver. (Customer supplied)

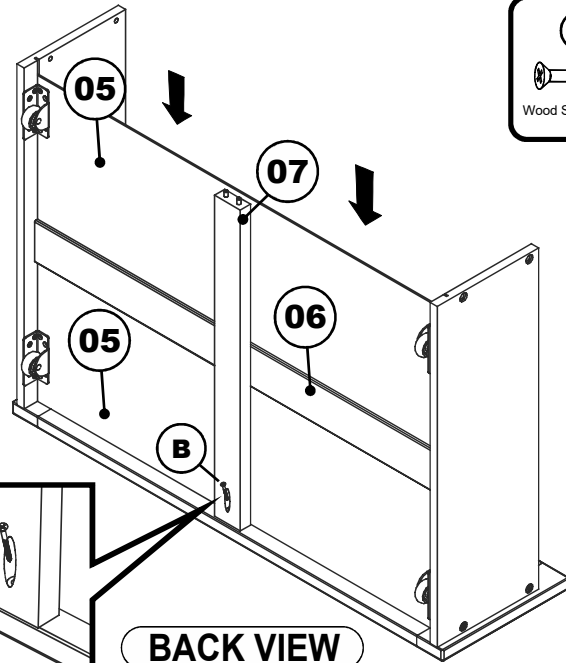
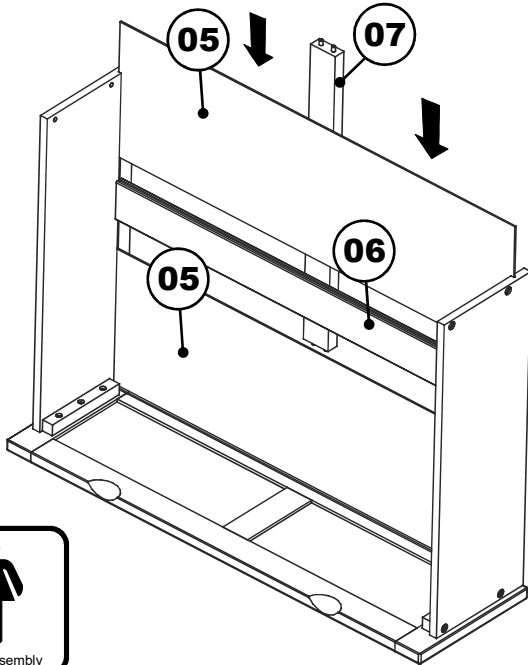

BACK VIEW

Step 3

Attach drawer back (04) to bed drawer assembly as shown. Use JCB M6 X 1" (A). Tighten with Allen wrench (C). Use wood screws 1 1/4" (B) to finish attaching drawer center support (07) to drawer back (04). Tighten with Phillips head screw driver. (customer supplied)

Step 4

Lastly, insert bed drawer to the bed as shown below.

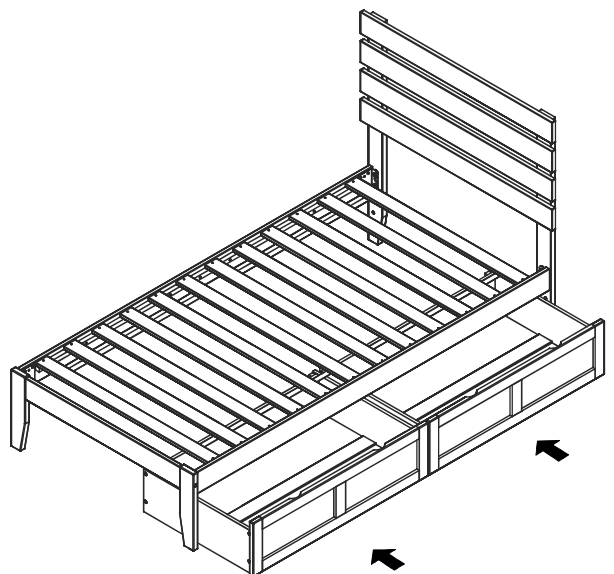
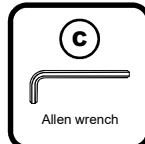
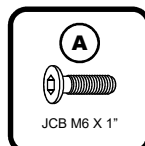
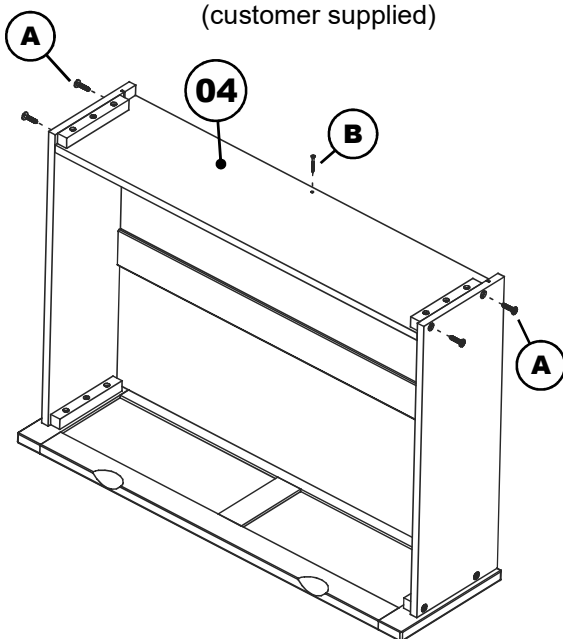

Congratulations!

Your bed drawer is now ready for use.

We recommend that you periodically recheck that all screws are tight to ensure lasting safety.