

Weight capacity : 75 kgs/ 165 Lbs

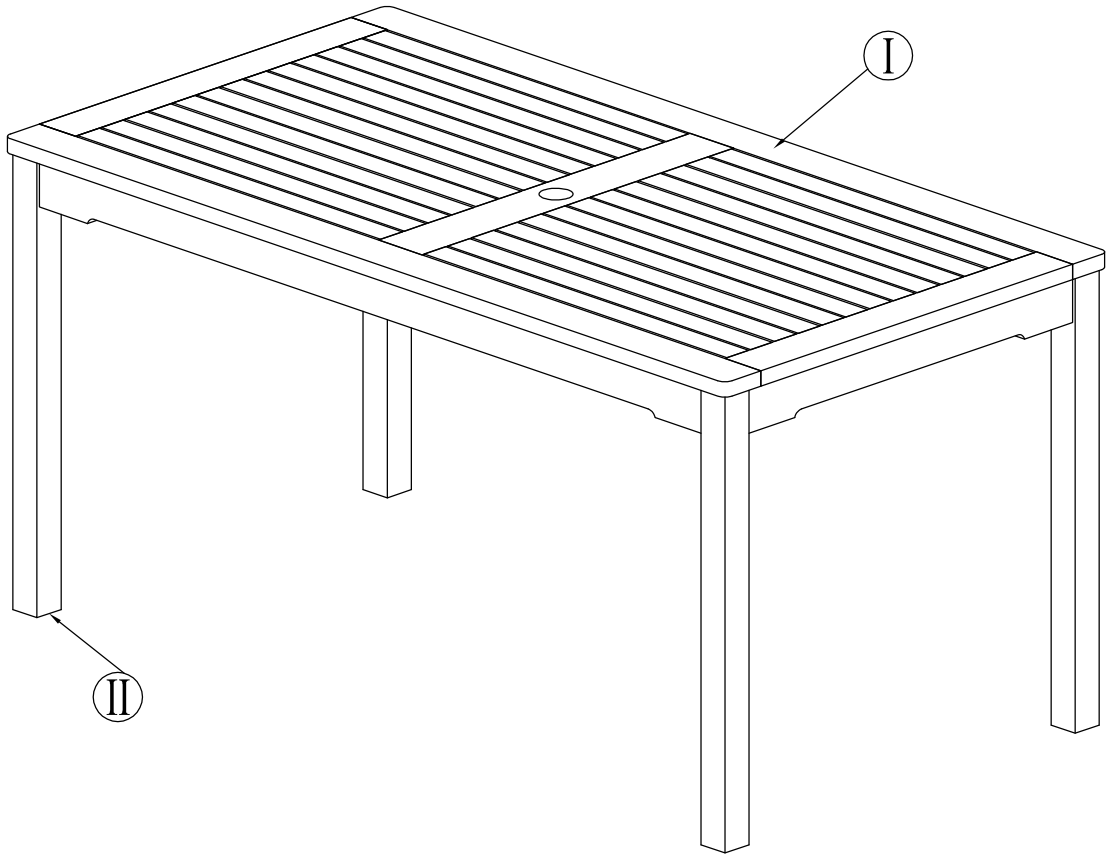



NOTE: 50% TIGHTEN BEFORE FIXING ALL BOLTS & SCREWS

COMPONENTS LIST

I

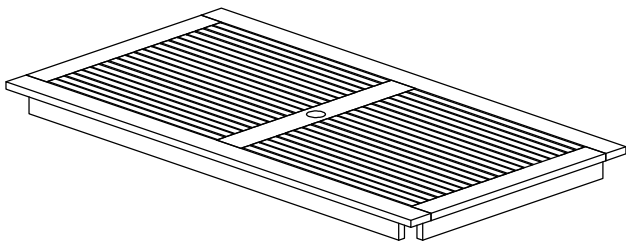

Q'TY 1

II

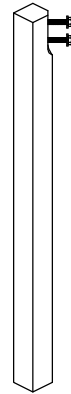

Q'TY 4

HARDWARE LIST

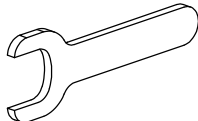
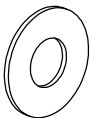
A		8	Hex. Nut	C		1	Spanner
B		8	Washer				

Step 1

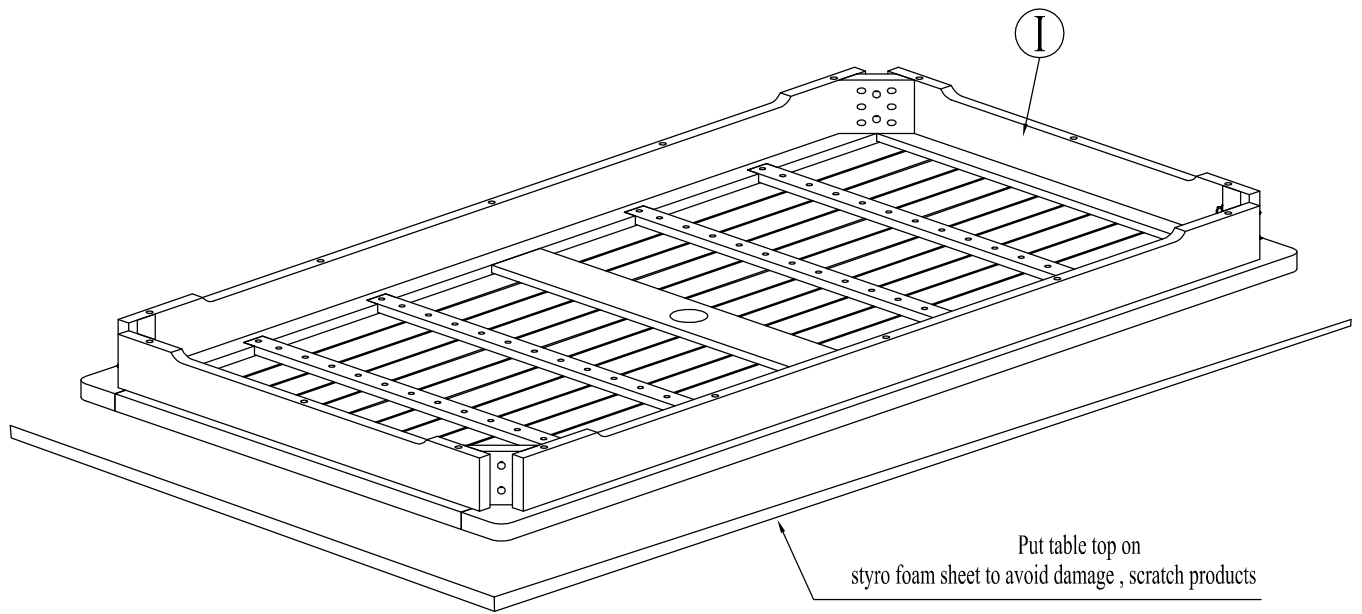

Step 2

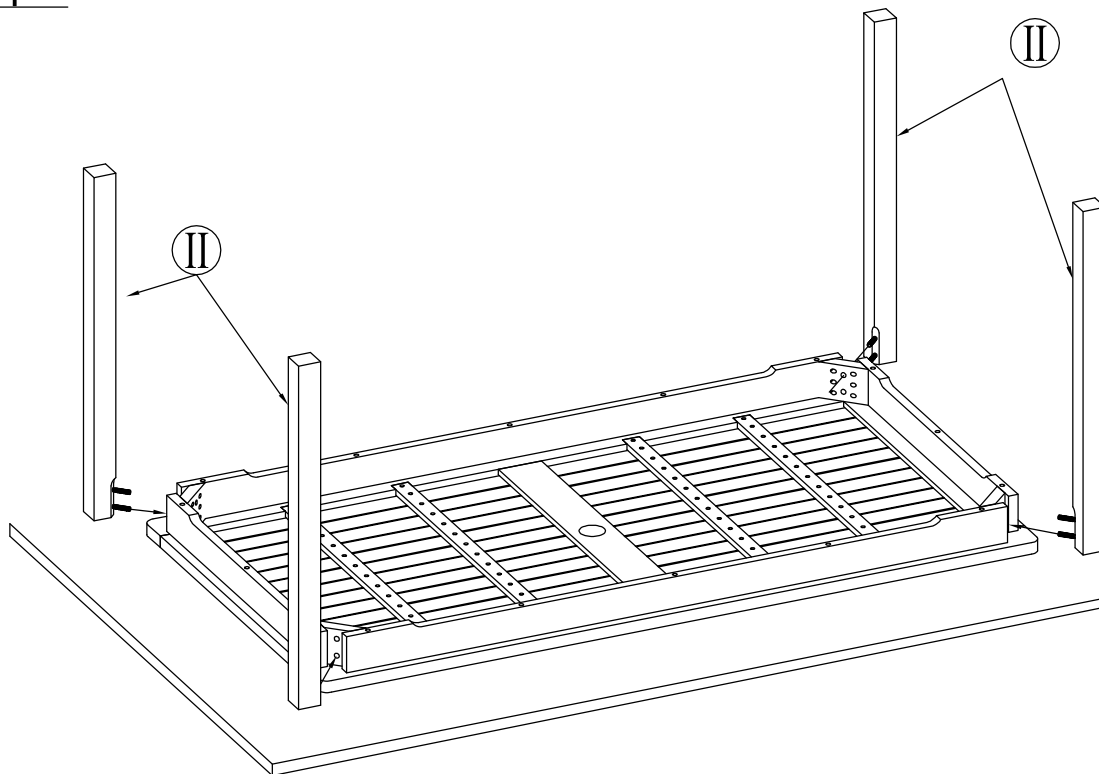

Step 3

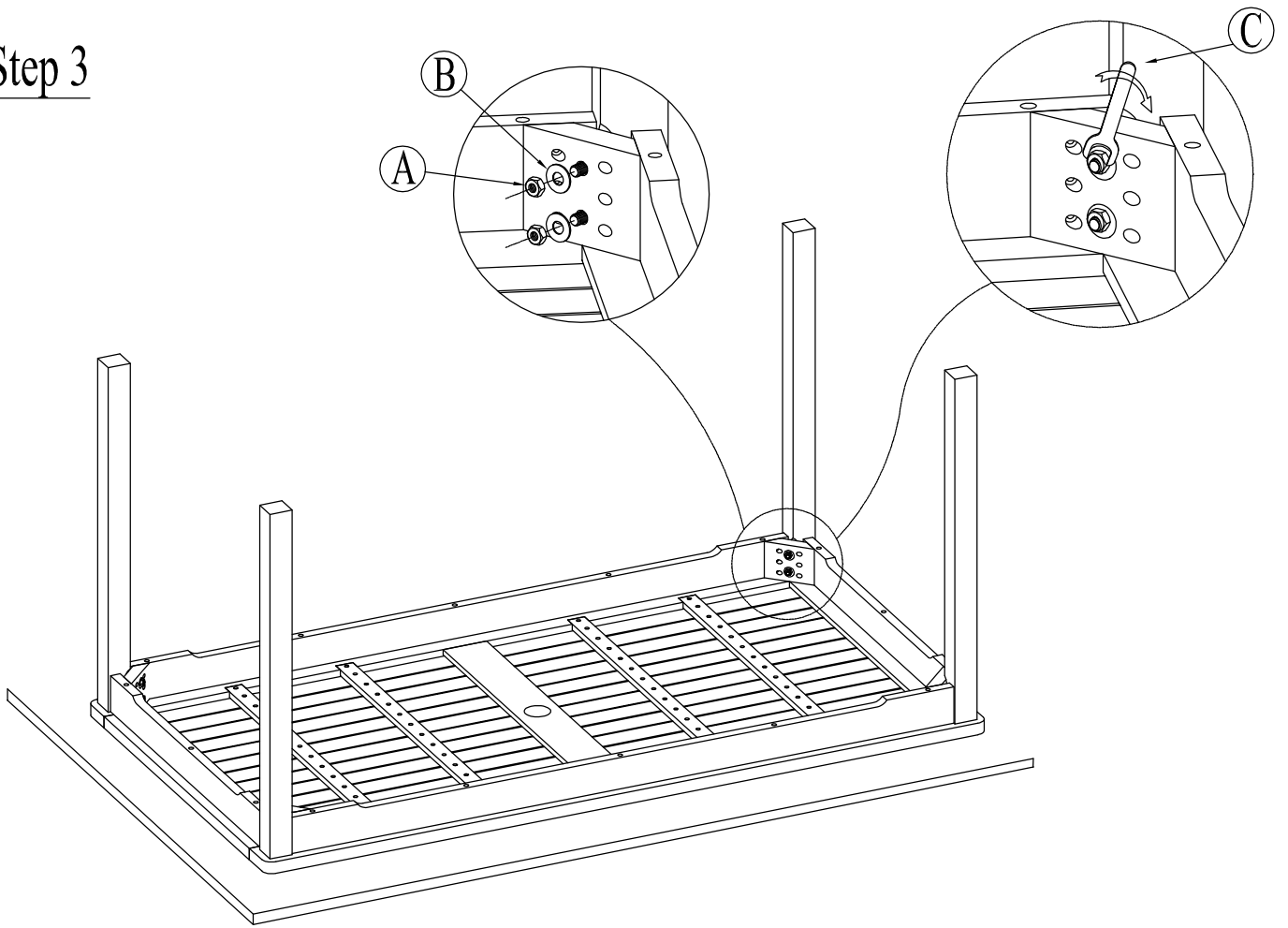

Step 4

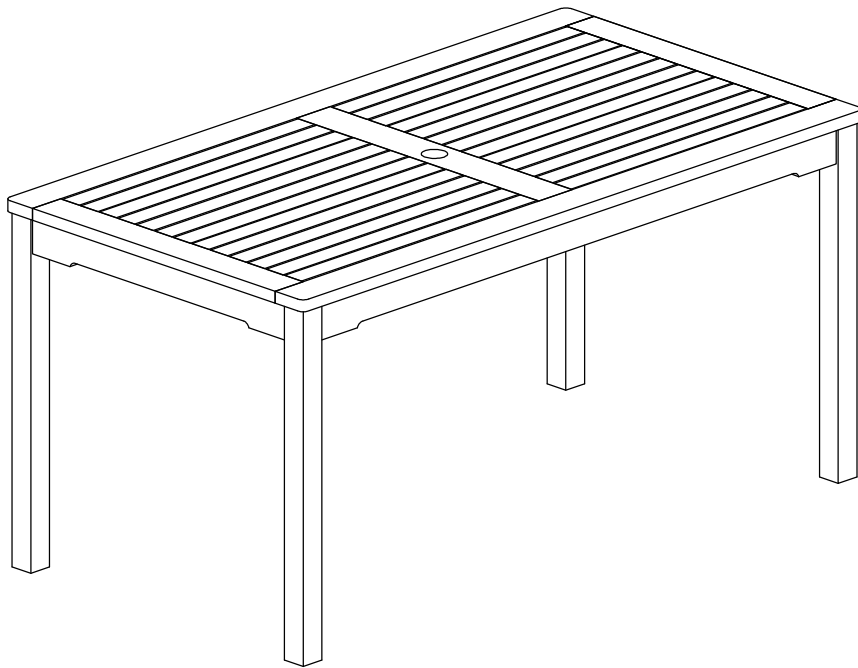

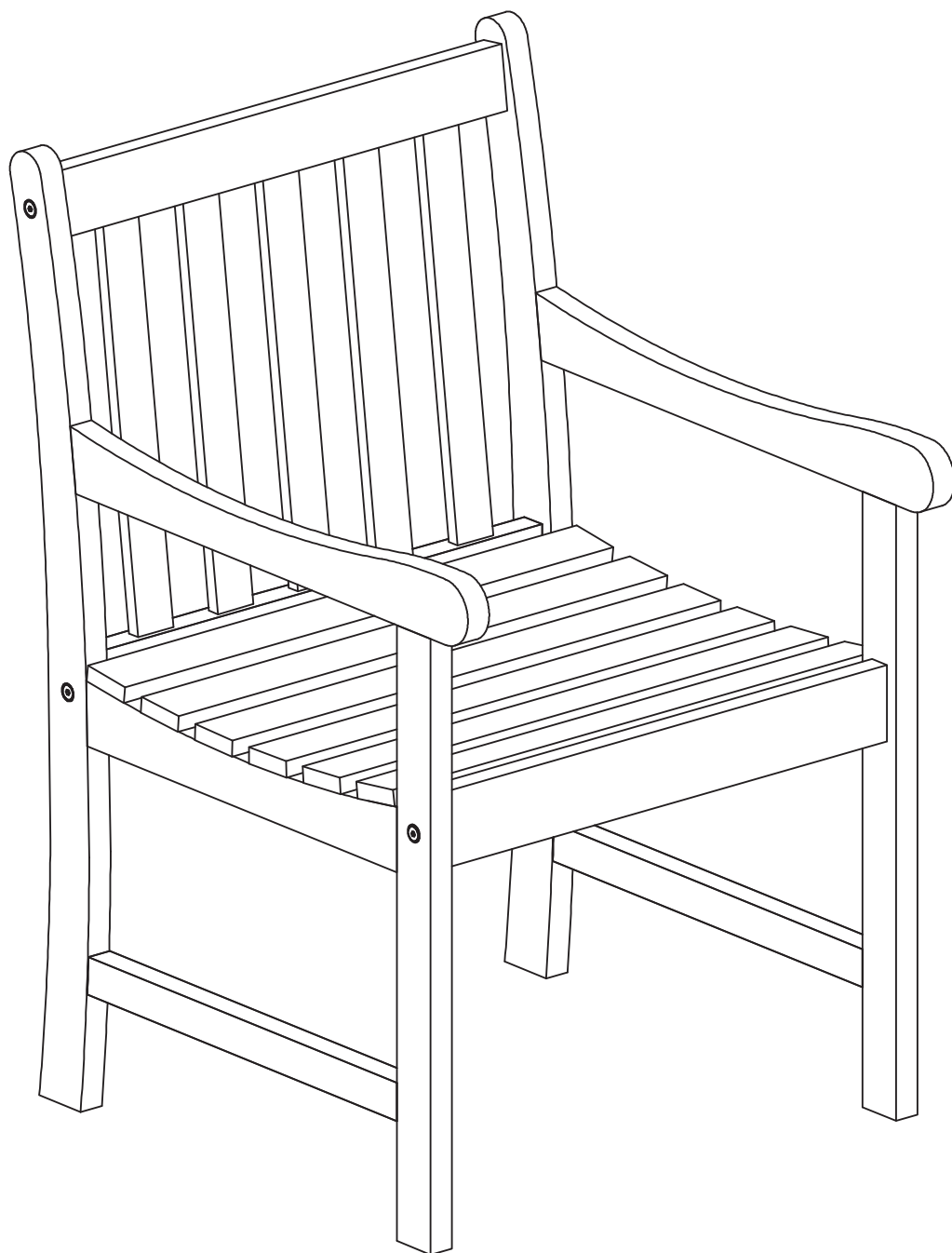

Maximum capacity : 110 kgs/242 Lbs



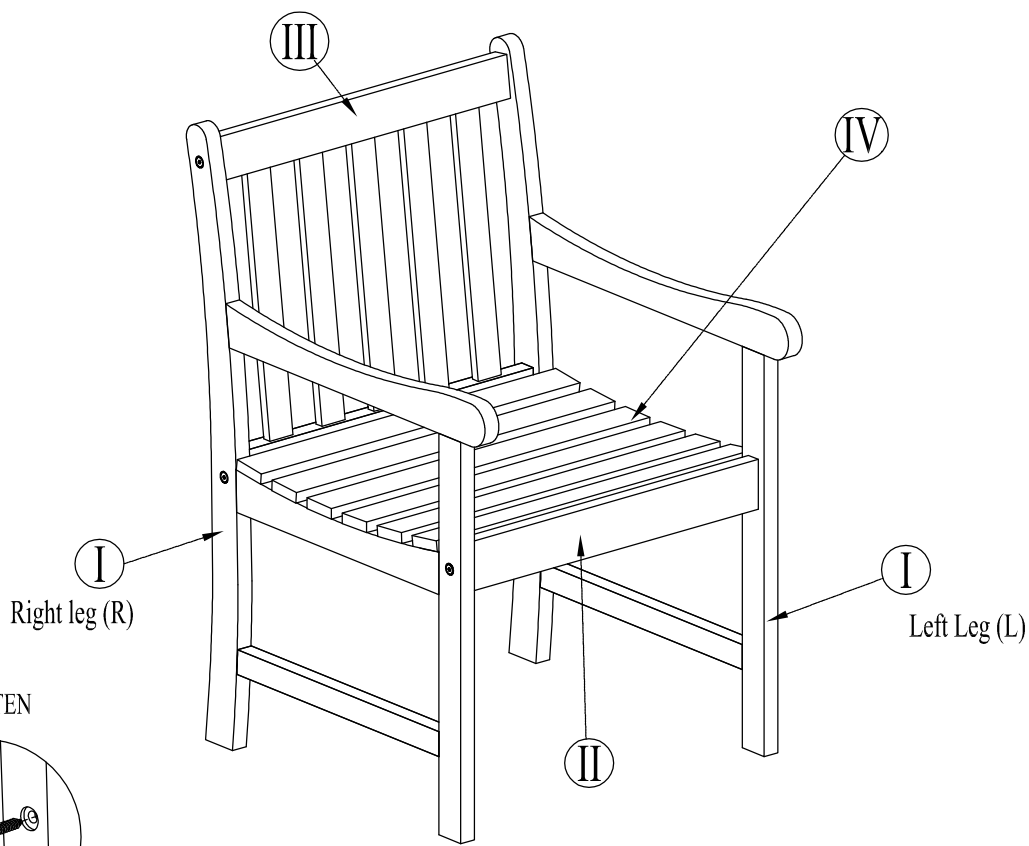

Right leg (R)

Left Leg (L)

TIGHTEN

LOOSEN

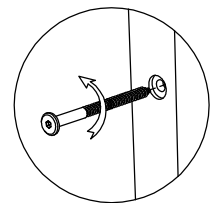
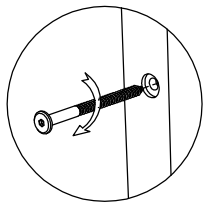

NOTE: 50% TIGHTEN BEFORE FIXING ALL BOLTS & SCREWS

COMPONENTS LIST

<p>Ⓘ</p> <p>Right leg (R) Left Leg (L)</p> <p>Q'TY 2</p>	<p>Ⓜ</p> <p>Q'TY 1</p>	<p>Ⓧ</p> <p>Q'TY 1</p>
<p>Ⓝ</p> <p>Q'TY 1</p>		

HARDWARE LIST

A		6	Screw 7 x 70	C		2	Allen Key
B		2	Screw 7x40				

Step 1

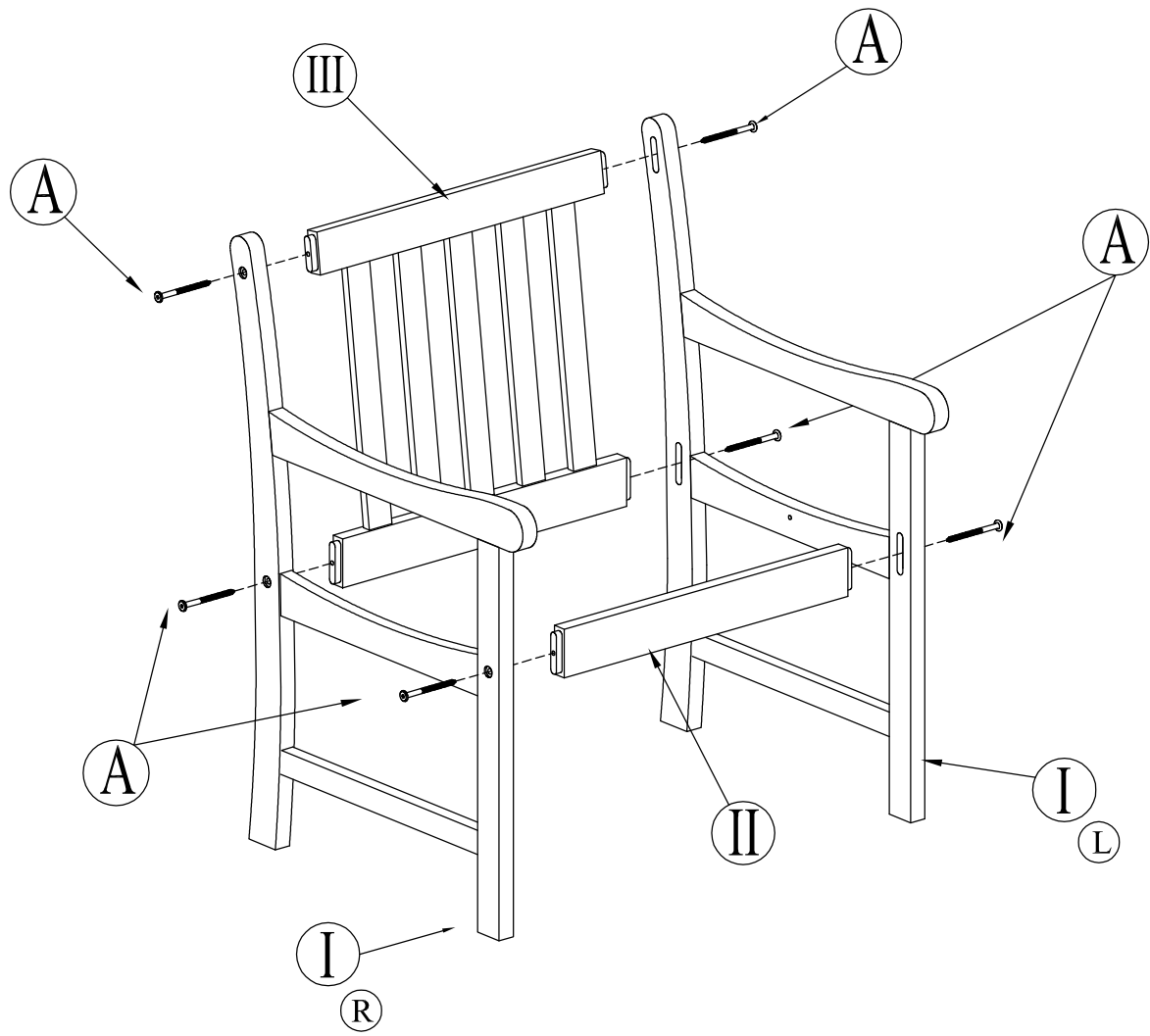

Step 2

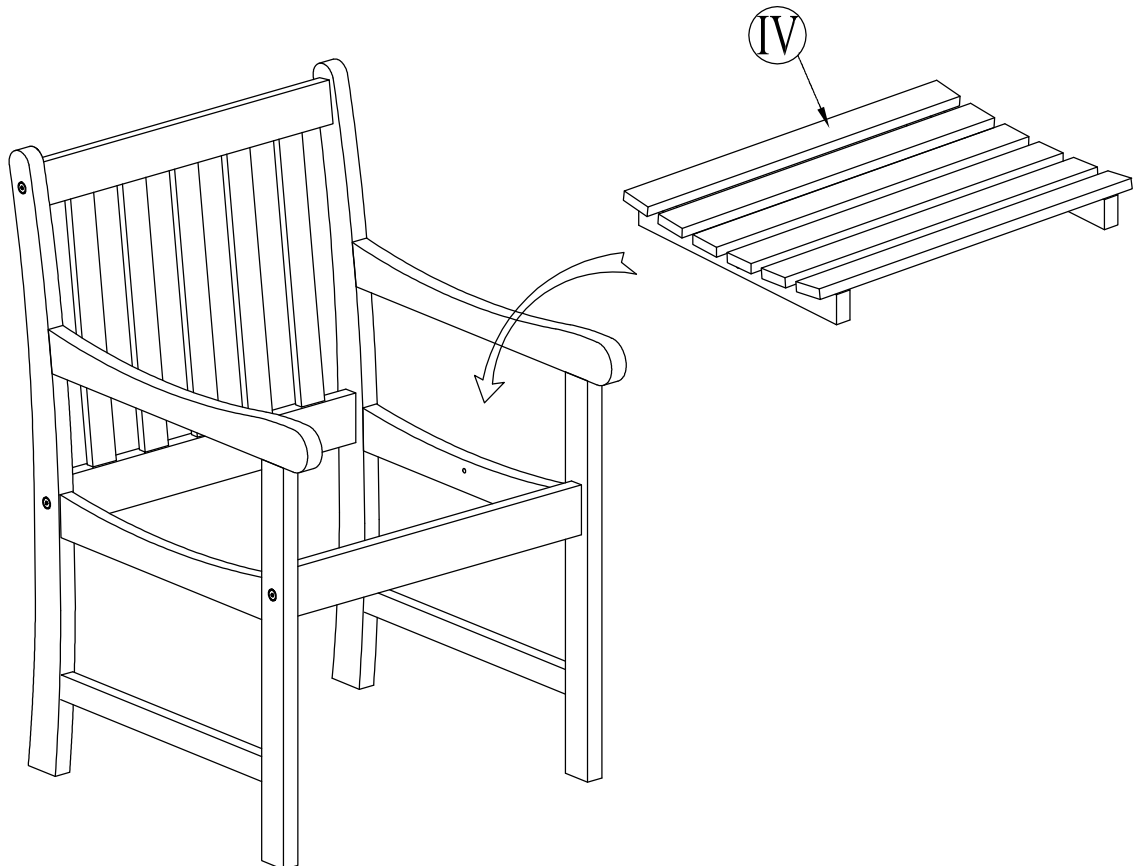

Step 3

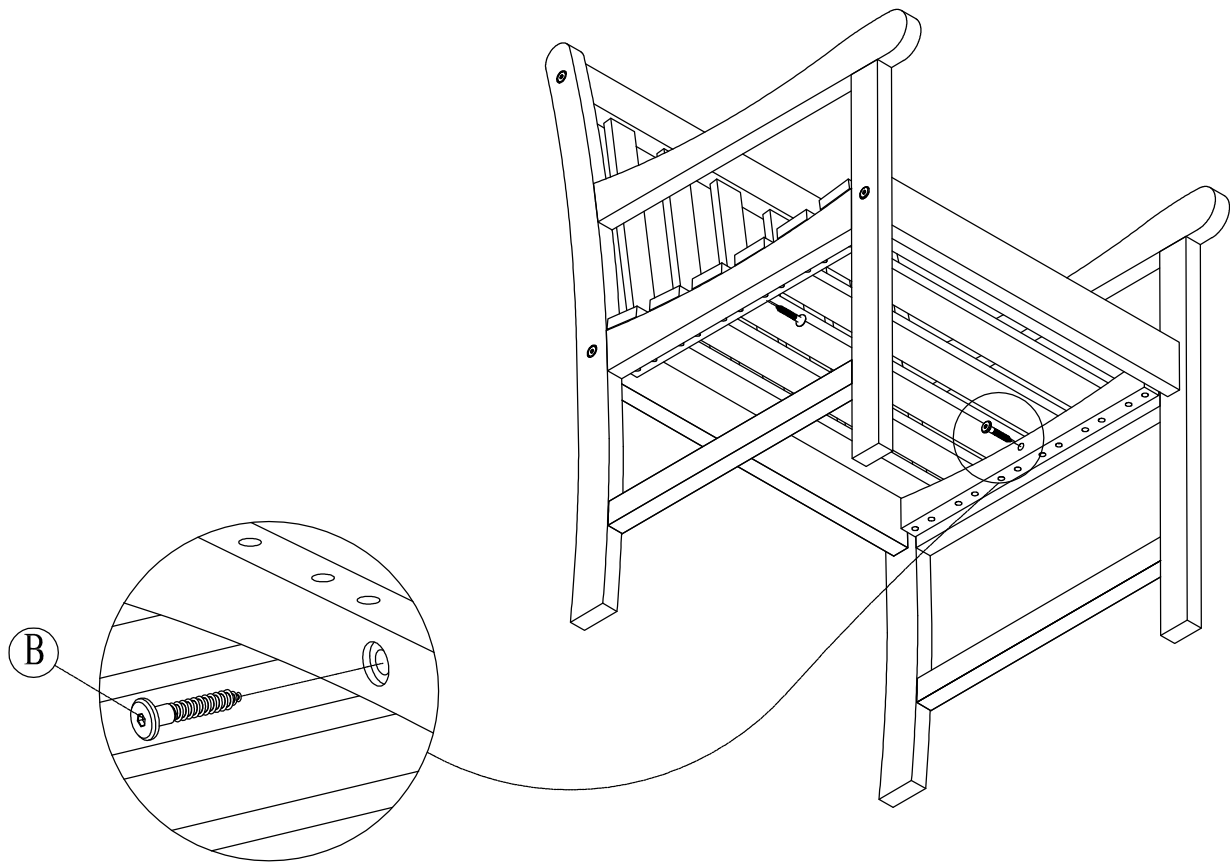

Step 4

