

1 Screw four pieces of Lower Poles (B) into the Handles (C).

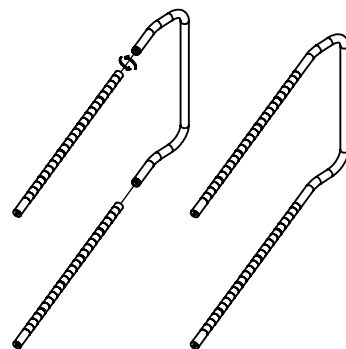

2 Ensure the Wire Shelf (A) positioned correctly. Hold the shelf and slide the down of each upright handle that made in Step(1) through the top of each corner opening of the Shelf until it temporarily stayed in the most top of upright handle.

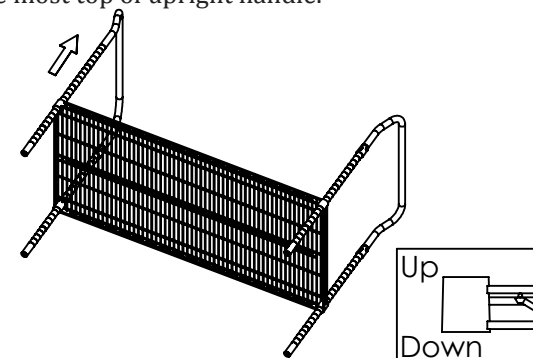

3 Snap Plastic Clips (D) utilizing the grooves of each lower pole at the same desired position making sure arrows of all the plastic clips pointing up, and then move the Wire Shelf down to fit the Plastic Clips tightly.

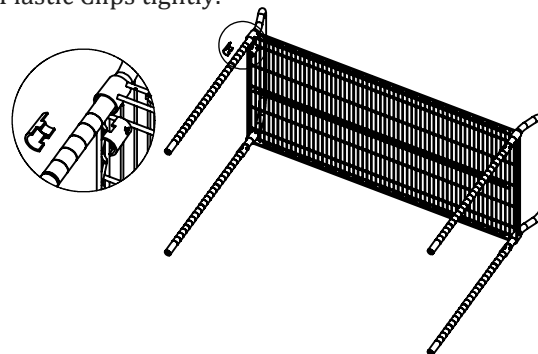

4 Repeat Step (2) & (3) to assemble the other two shelves on the desired positions of two upright handles. Push down firmly every wire shelf at corners using rubber mallet to ensure all the shelves are in place covering plastic clips evenly at each corner.

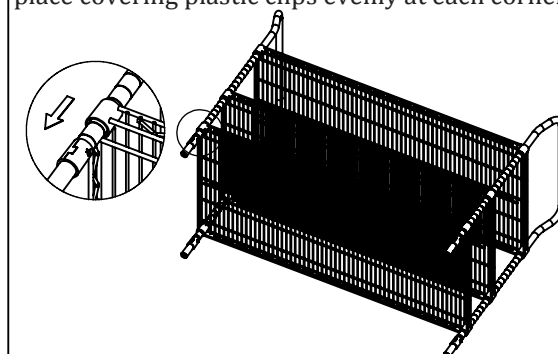

5 Putting the Plastic Bumpers (E) through each bottom of upright handle and then screw the Swivel Castors (F) and the ones with brakes (G). Be noted that the brakes ones are usually assembled at the same side of an upright handle.

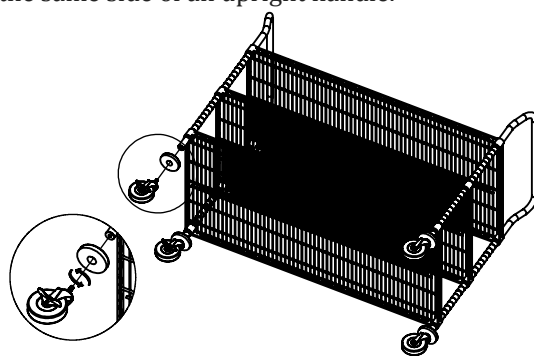

6 Using the Wrench (H) to screw all castors to attain proper position if needed.

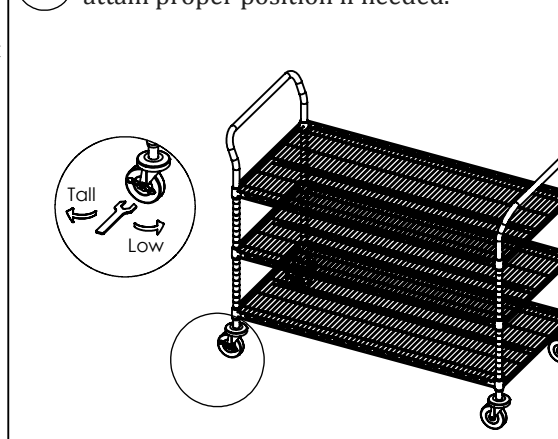

No.	A	B	C	D
name	Wire Shelf	Lower Pole	Handle	Plastic Clip
Parts				 2 pcs spare
QTY	3 pcs	4 pcs	2 pcs	26 pcs
No.	E	F	G	H
name	Plastic Bumper	Swivel Castors	Swivel Castors with brakes	Wrench
Parts				
QTY	4 pcs	2 pcs	2 pcs	1 pc