

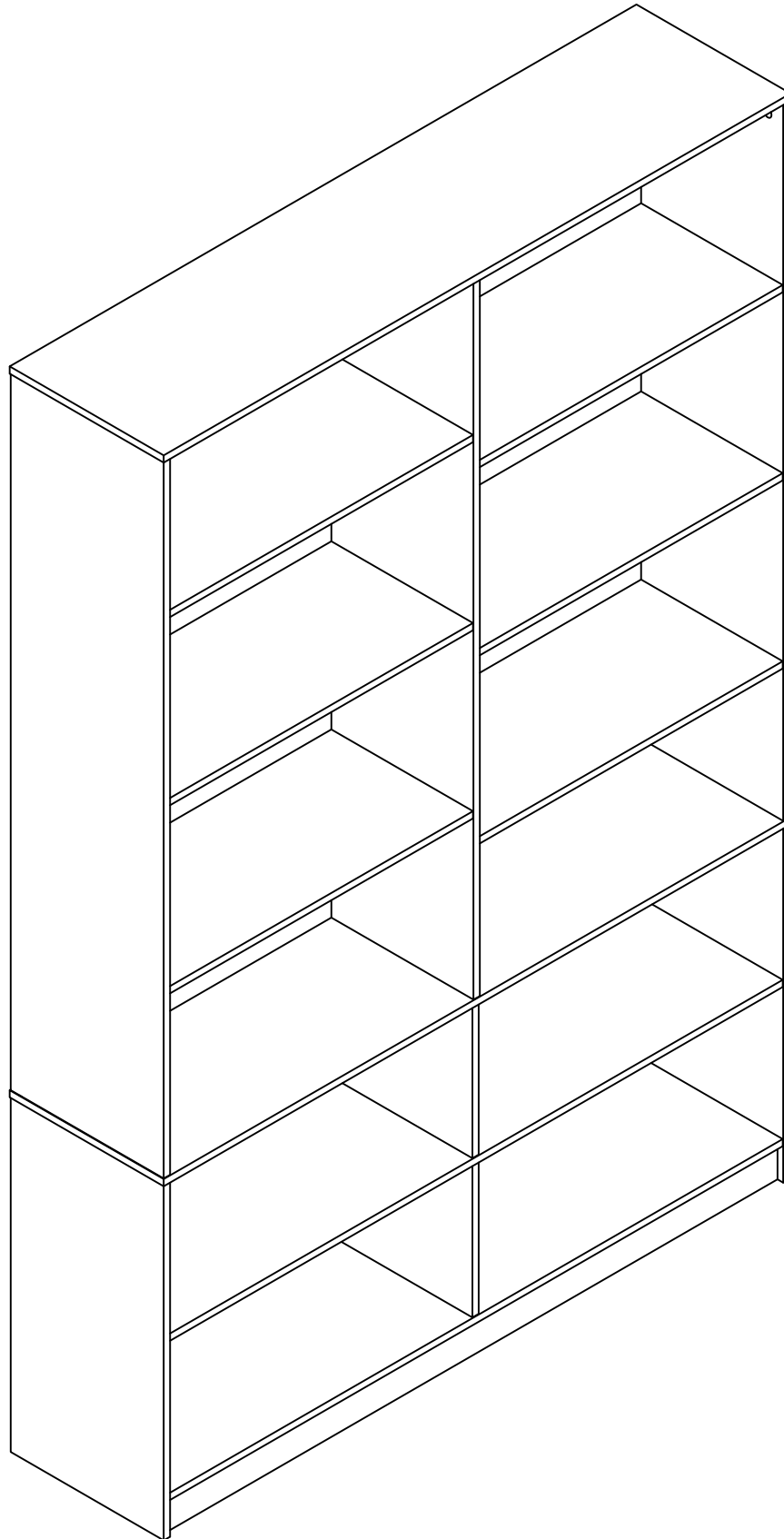

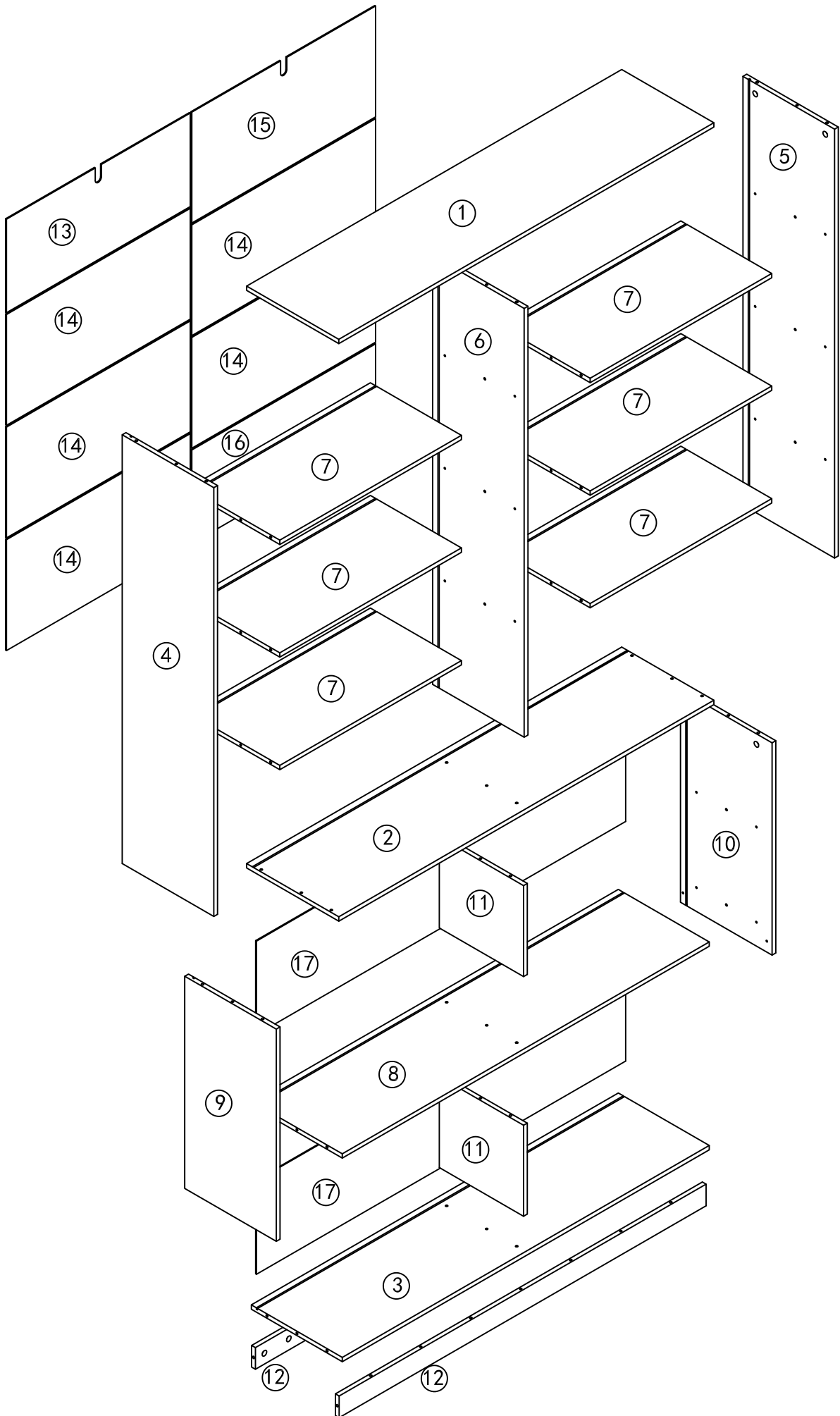







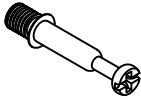
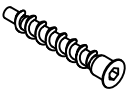

Installation & Assembly



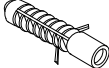

<p>A</p>  <p>58+2PCS</p>	<p>B</p>  <p>58+2PCS</p>	<p>C</p>  <p>M5*48MM 10+1PCS</p>	<p>D</p>  <p>M3*20*57MM 1PCS</p>
<p>E</p>  <p>∅6*30MM 34+2PCS</p>	<p>F</p>  <p>12+1PCS</p>	<p>G</p>  <p>48+2PCS</p>	<p>H</p>  <p>∅3*16MM 48+2PCS</p>
<p>I</p>  <p>2PCS</p>	<p>J</p>  <p>∅4*35MM 2PCS</p>	<p>K</p>  <p>2PCS</p>	<p>L</p>  <p>∅4*12MM 2PCS</p>

STEP 1

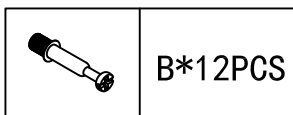
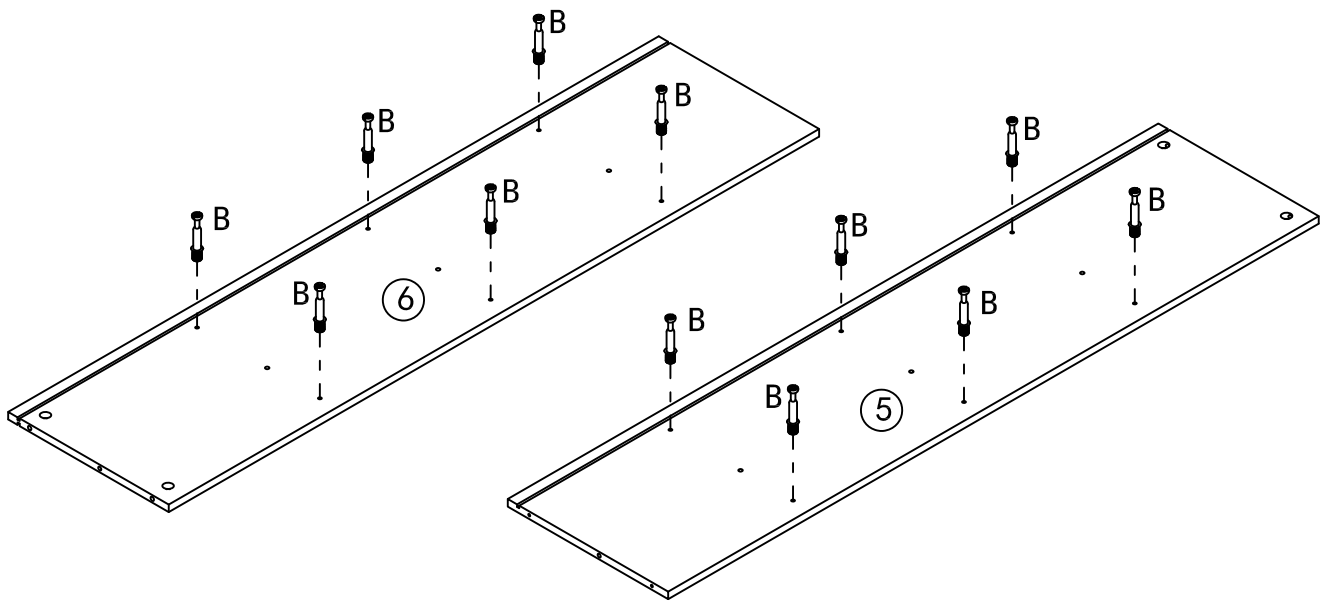

STEP 2

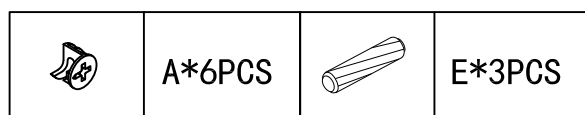
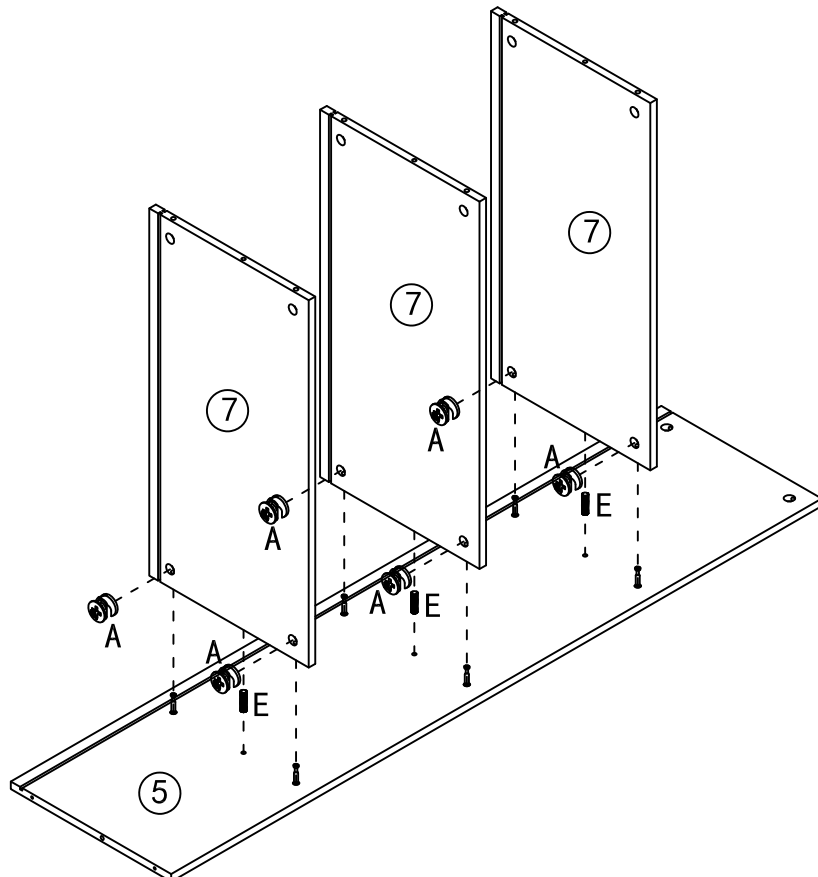

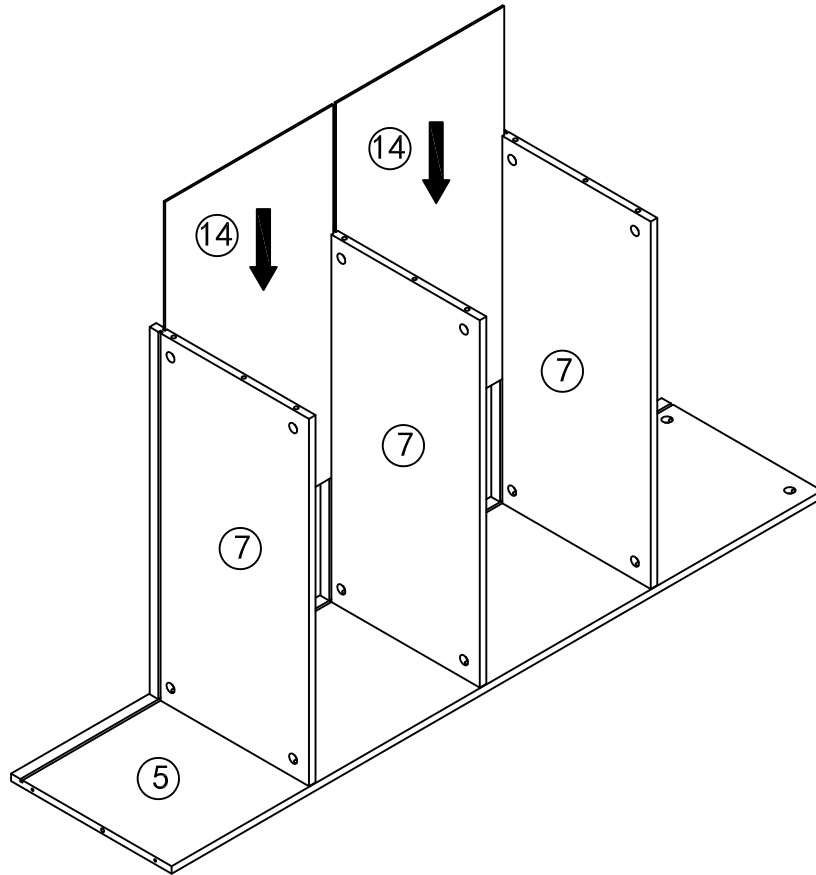

STEP 3

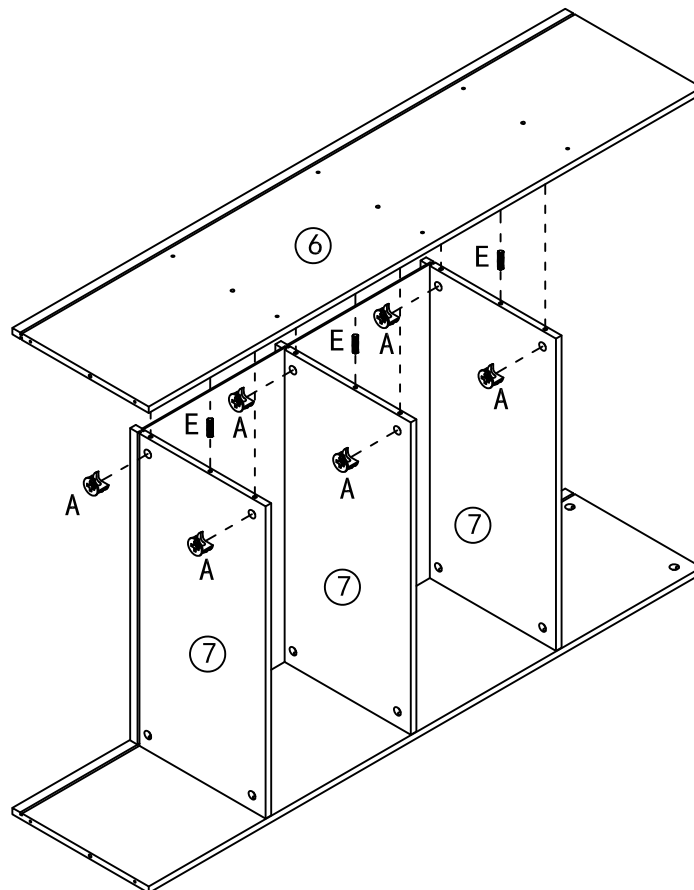

STEP 4



	A*6PCS		E*3PCS
---	--------	---	--------

STEP 5

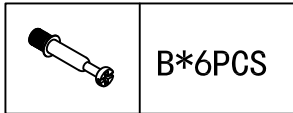
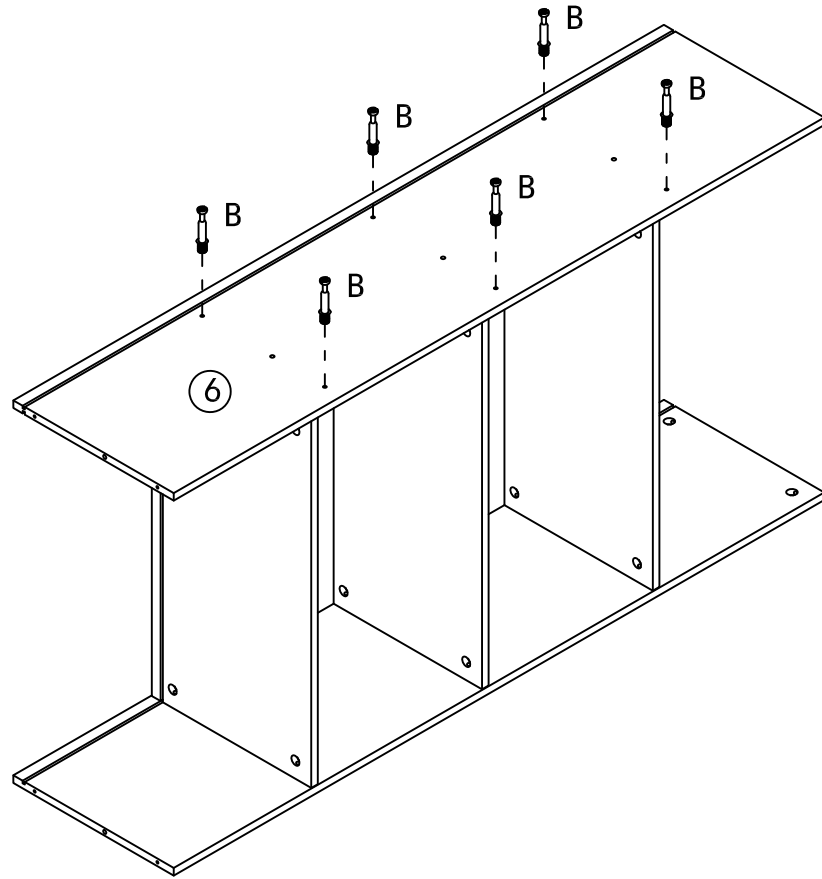

STEP 6

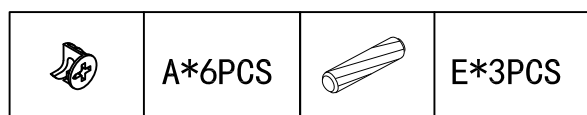
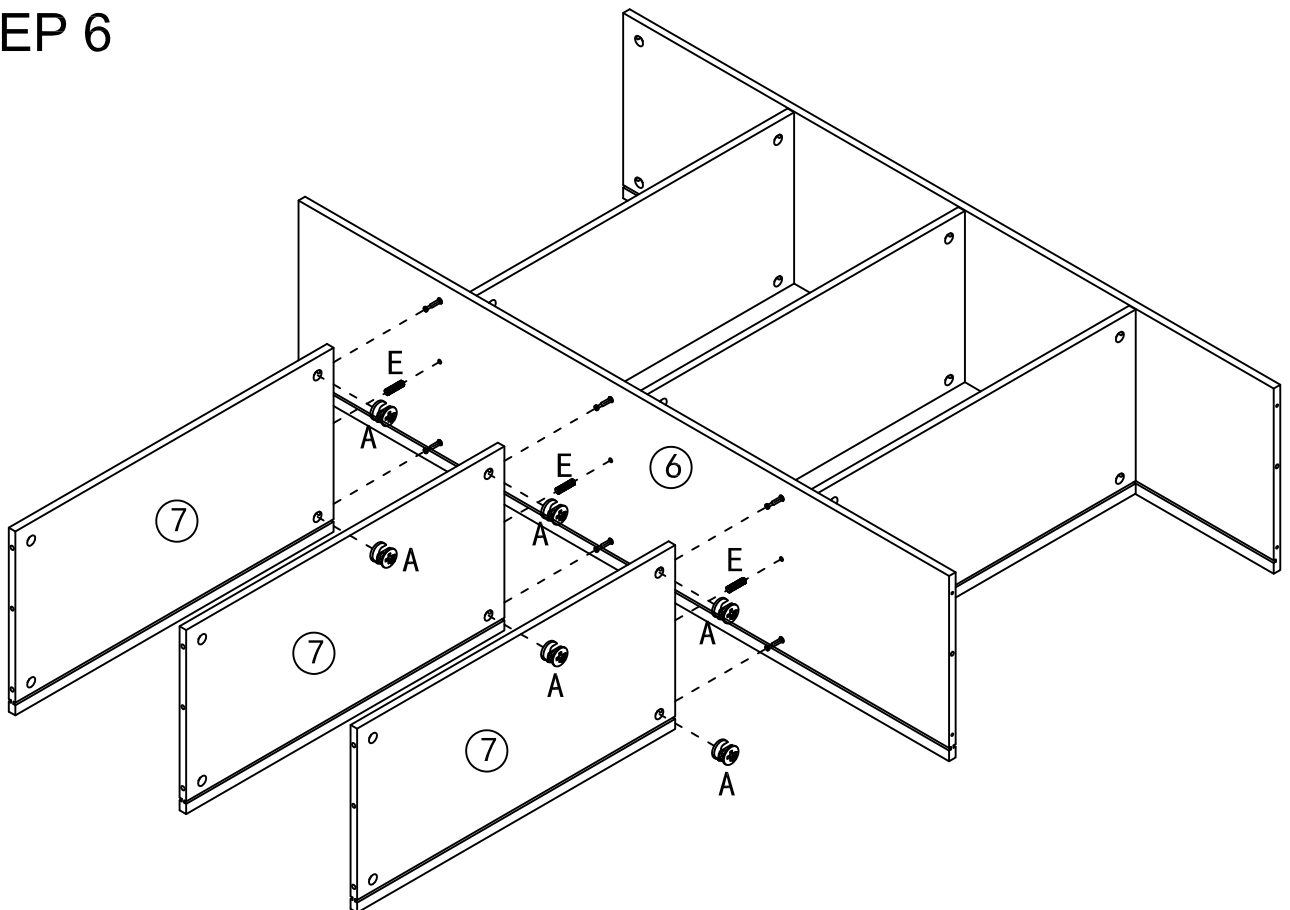

STEP 7

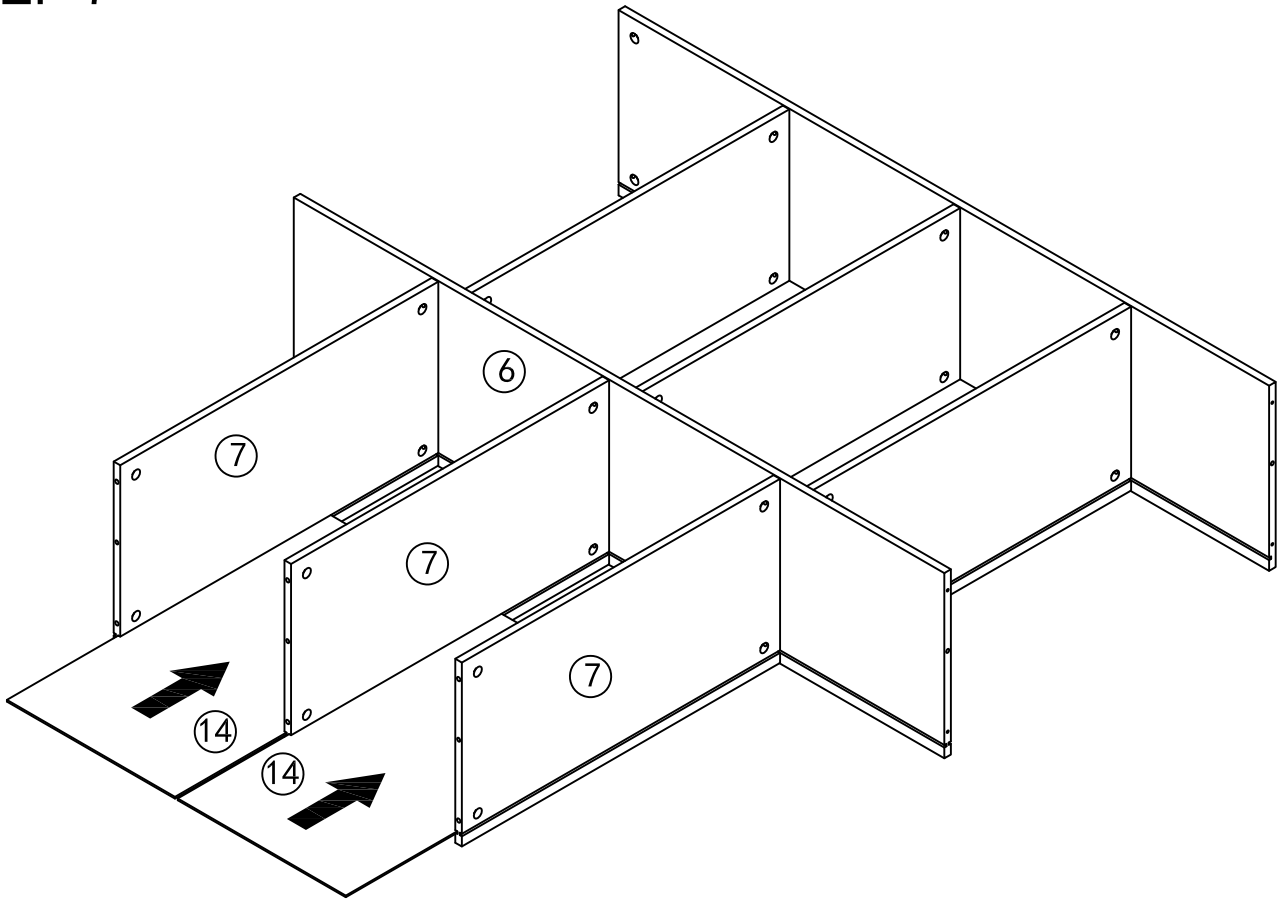

STEP 8

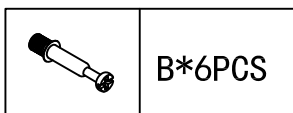
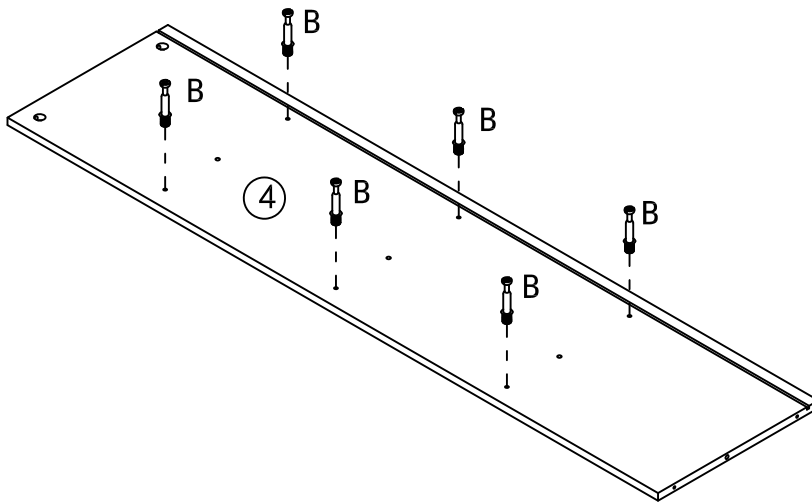

STEP 9

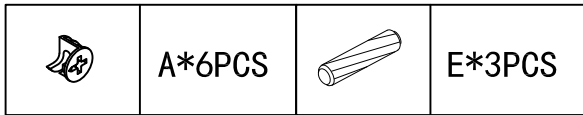
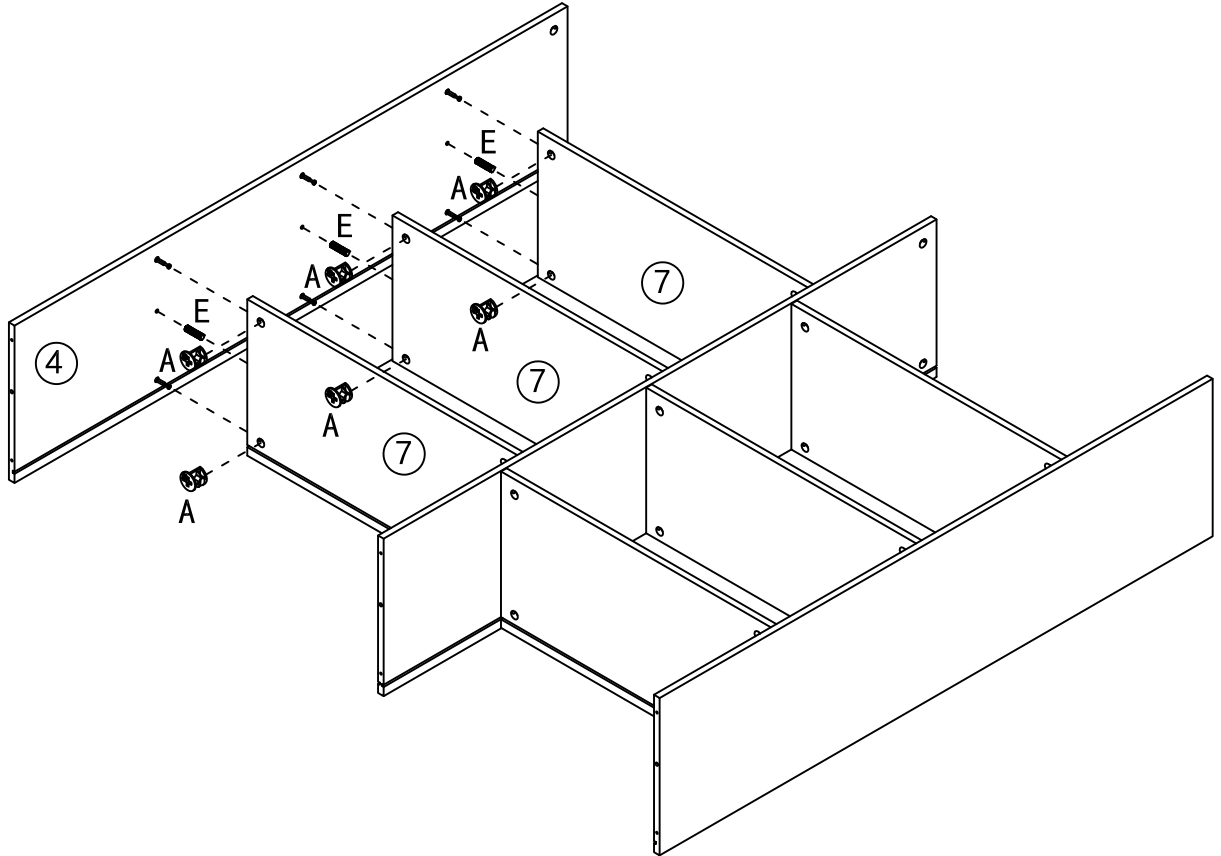

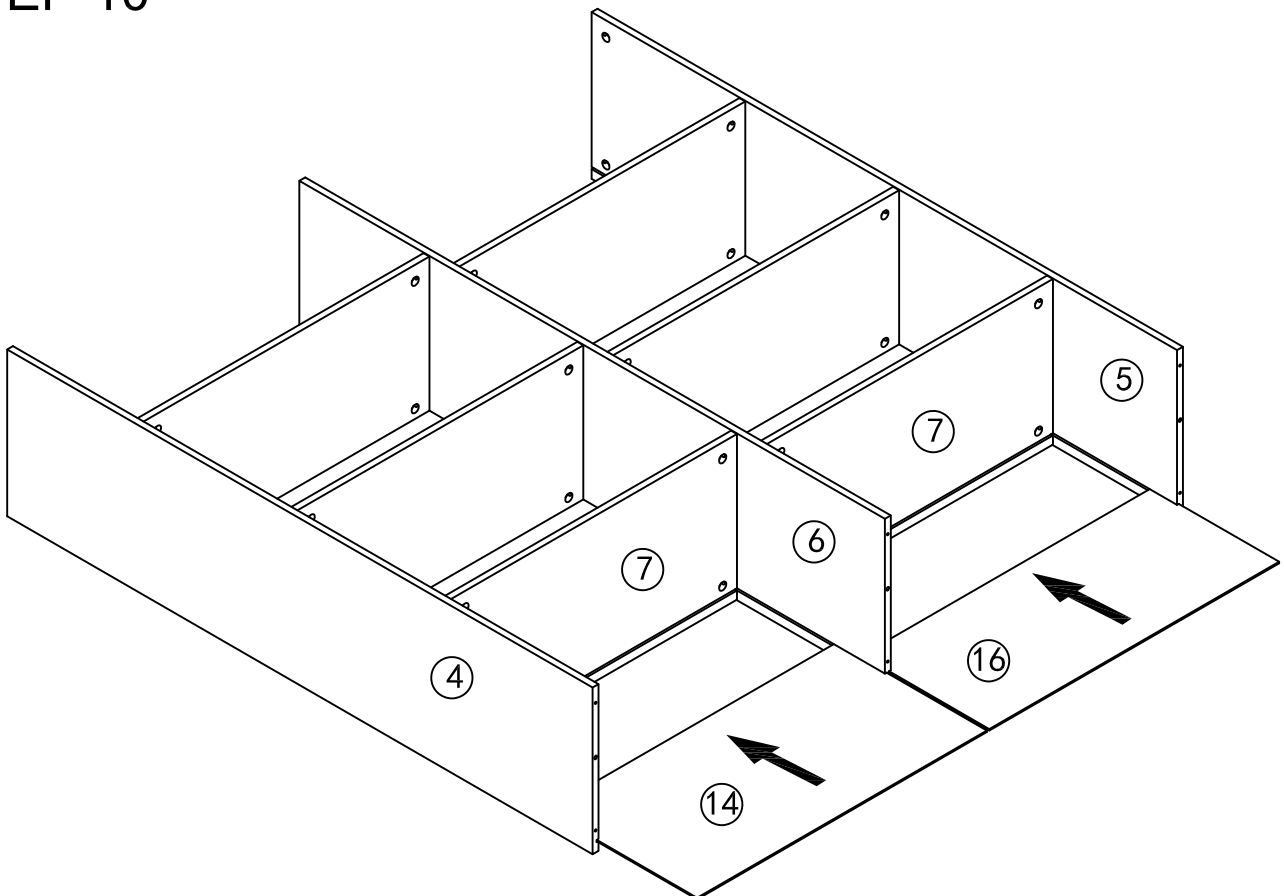

STEP 10

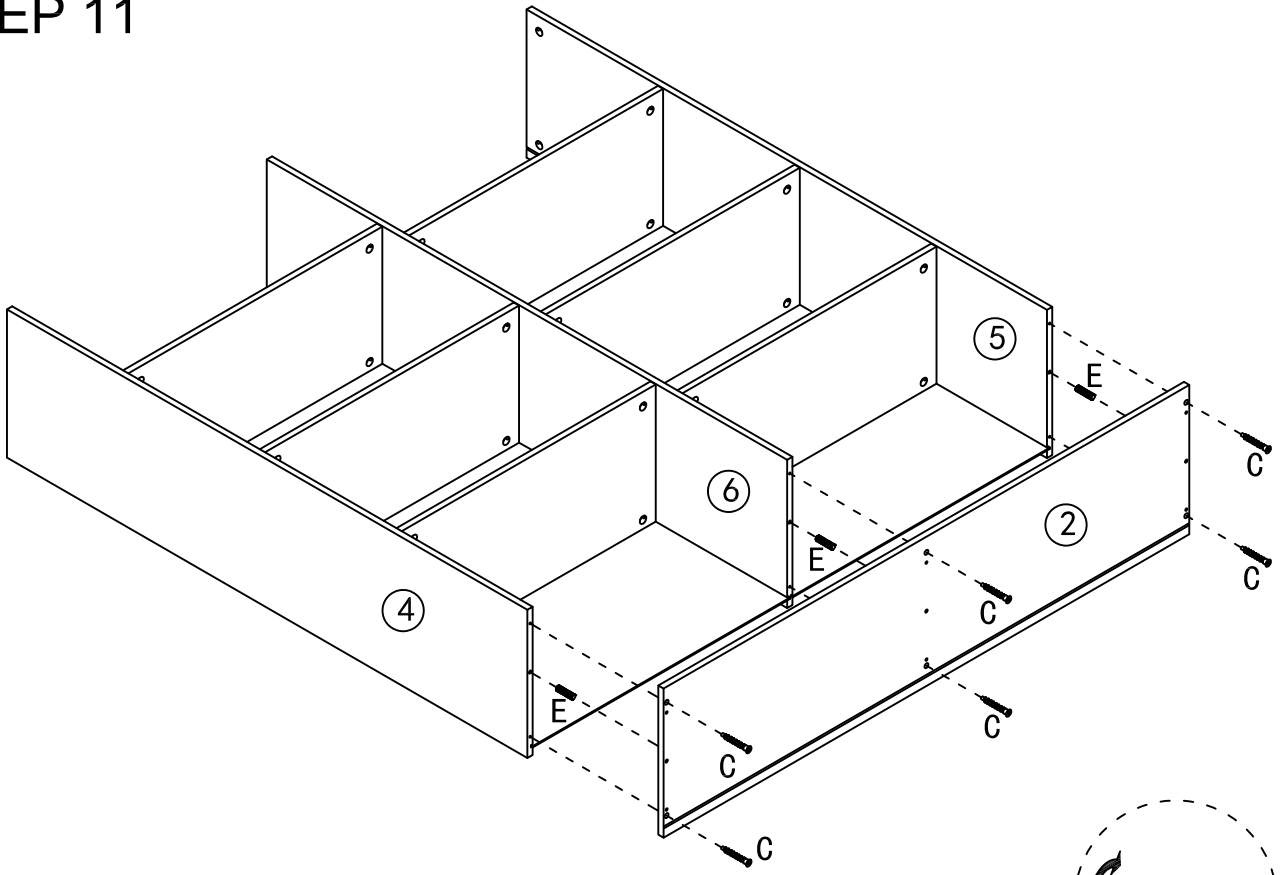

STEP 11



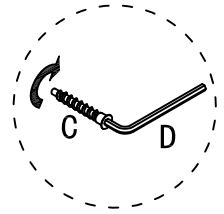

	C*6PCS		D*1PCS		E*3PCS
---	--------	---	--------	---	--------

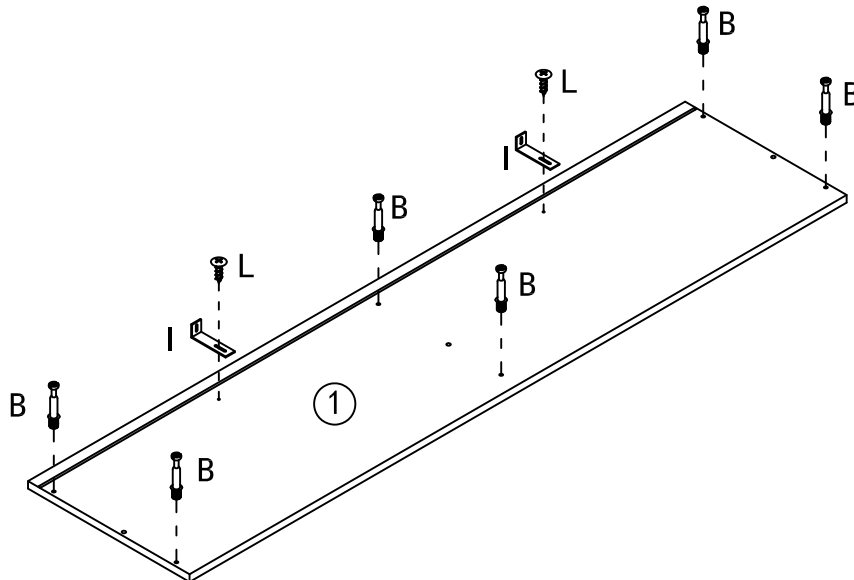

STEP 12





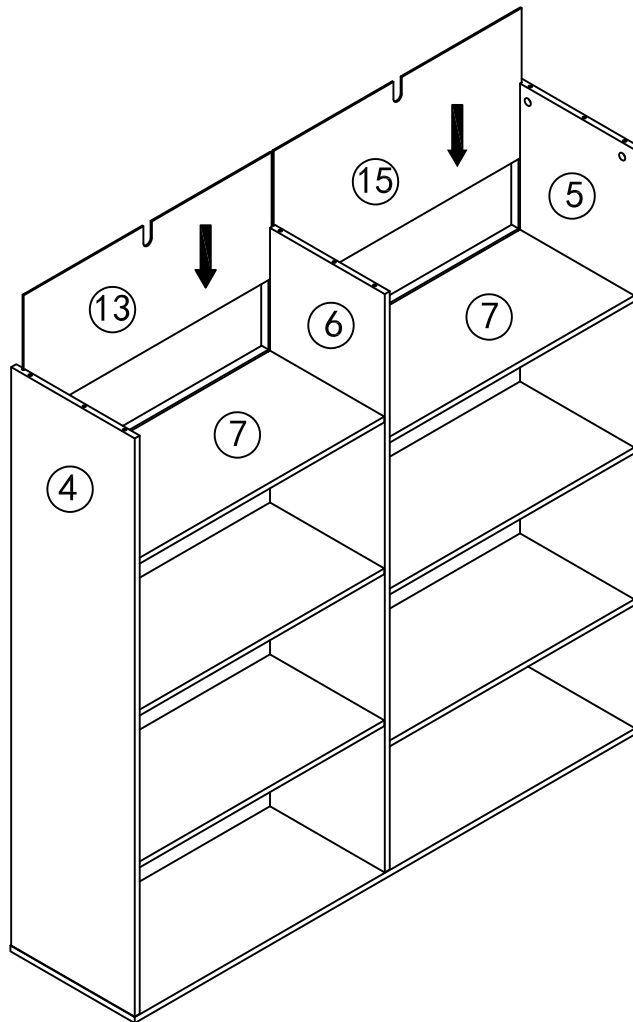

	B*6PCS		I*2PCS		L*2PCS
---	--------	---	--------	---	--------

STEP 13

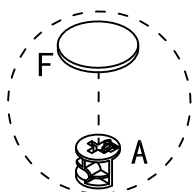
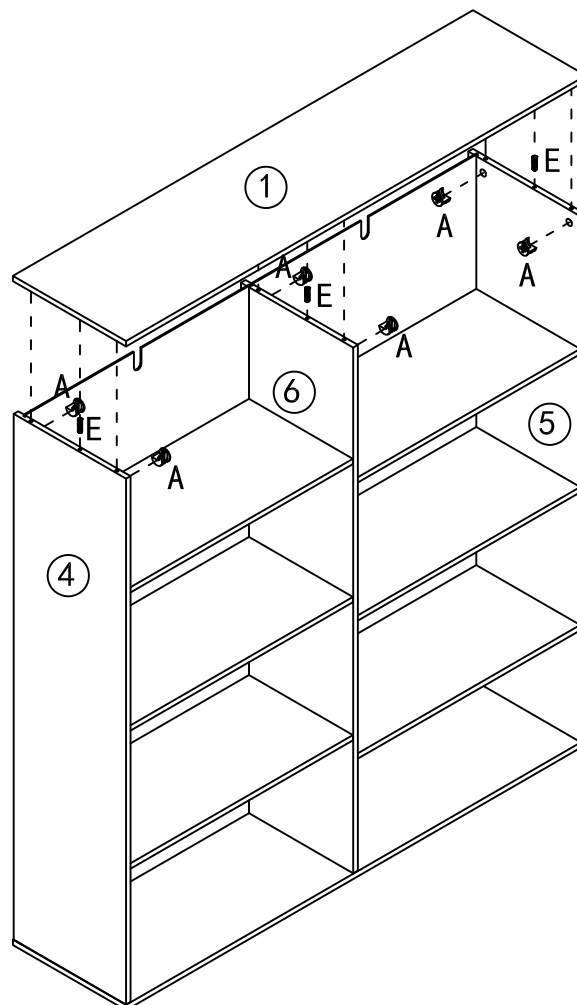

STEP 14



	F*6PCS		
	A*6PCS		E*3PCS

STEP 15

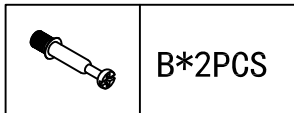
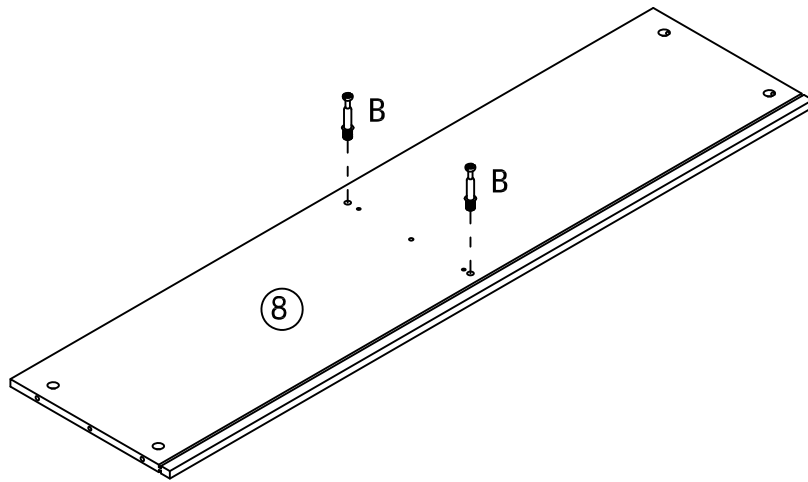

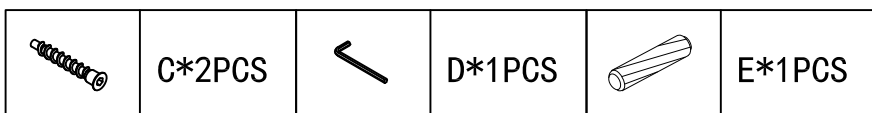
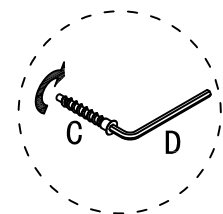
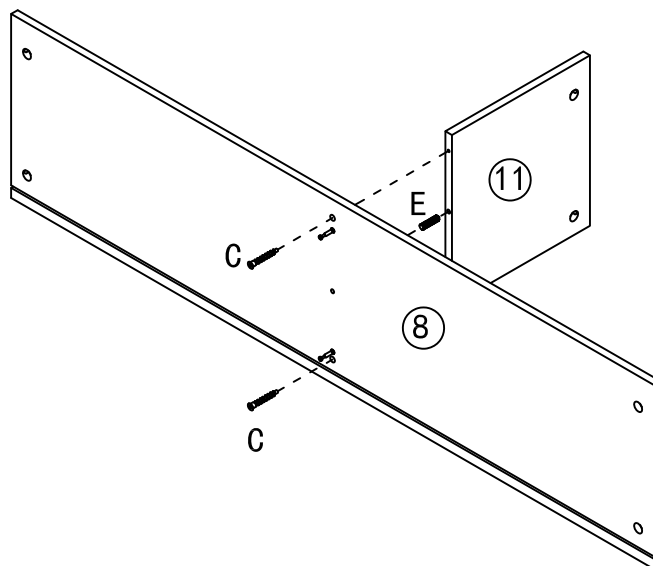

STEP 16



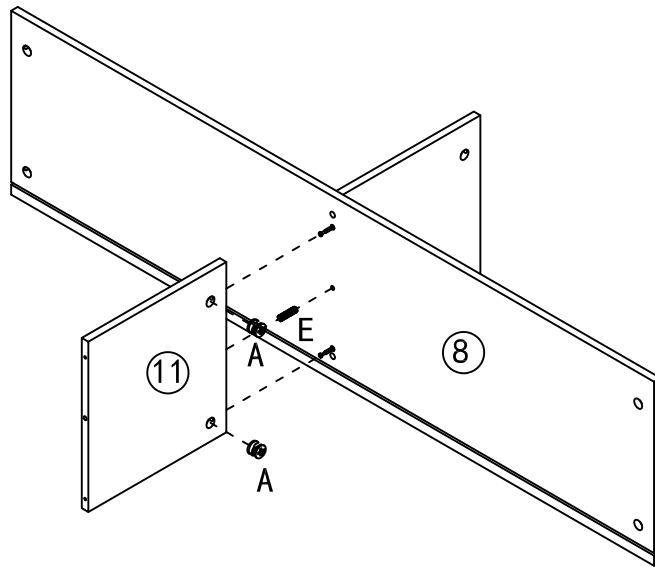

STEP 17



	A*2PCS		E*1PCS
---	--------	---	--------

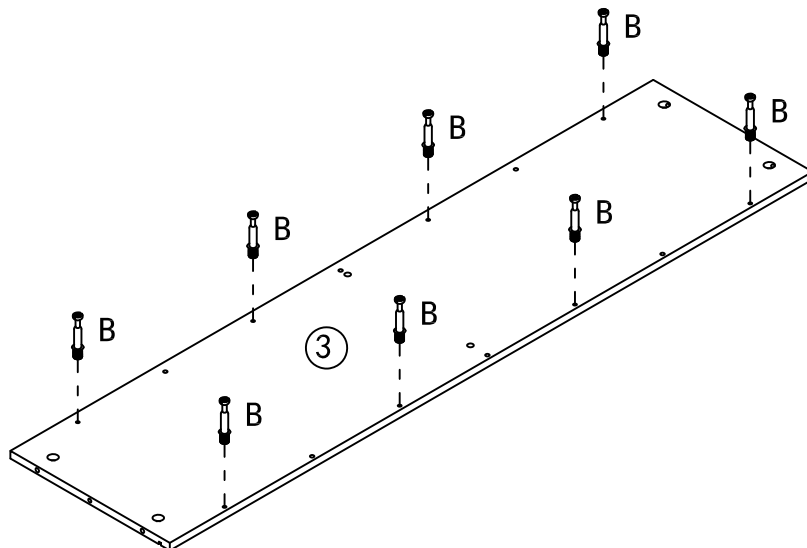

STEP 18



	B*8PCS
---	--------

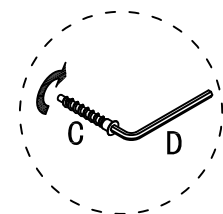
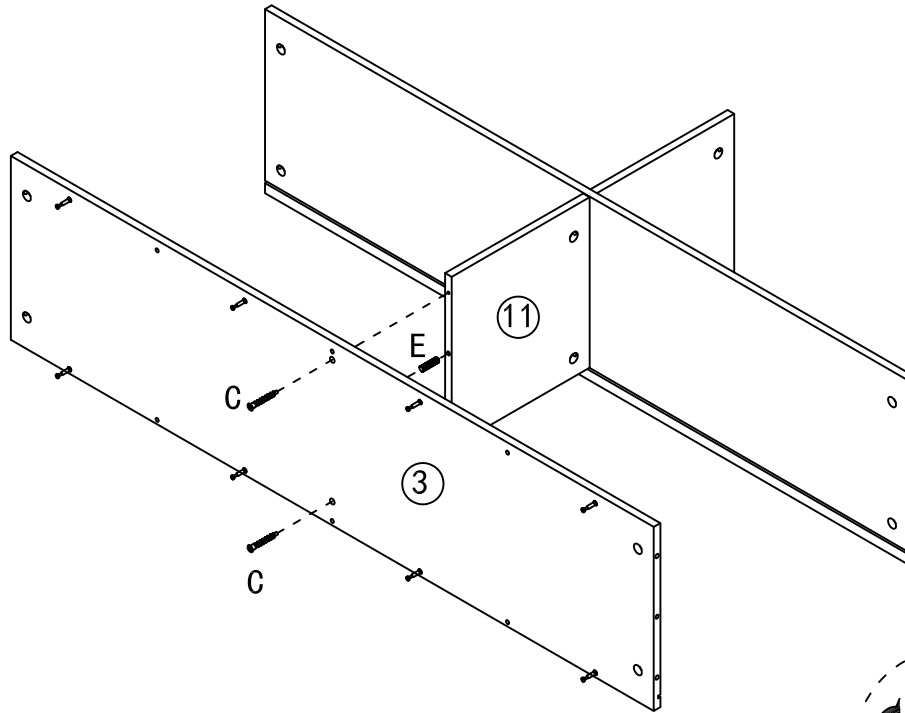

STEP 19

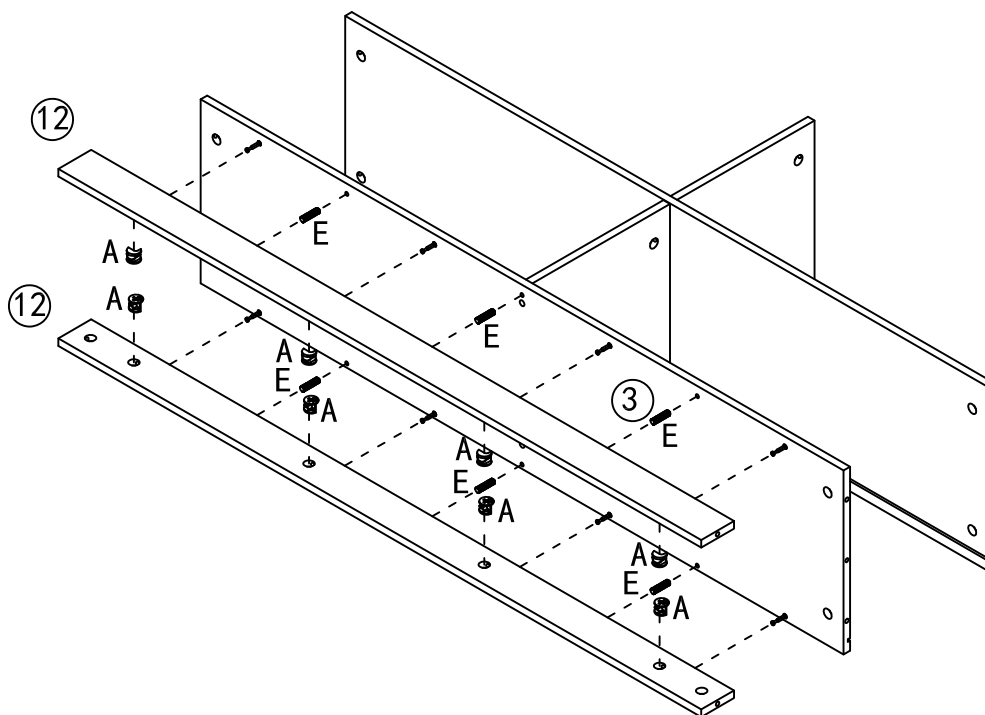

	C*2PCS		D*1PCS		E*1PCS
---	--------	---	--------	---	--------

STEP 20



	A*8PCS		E*6PCS
---	--------	---	--------

STEP 21

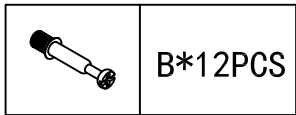
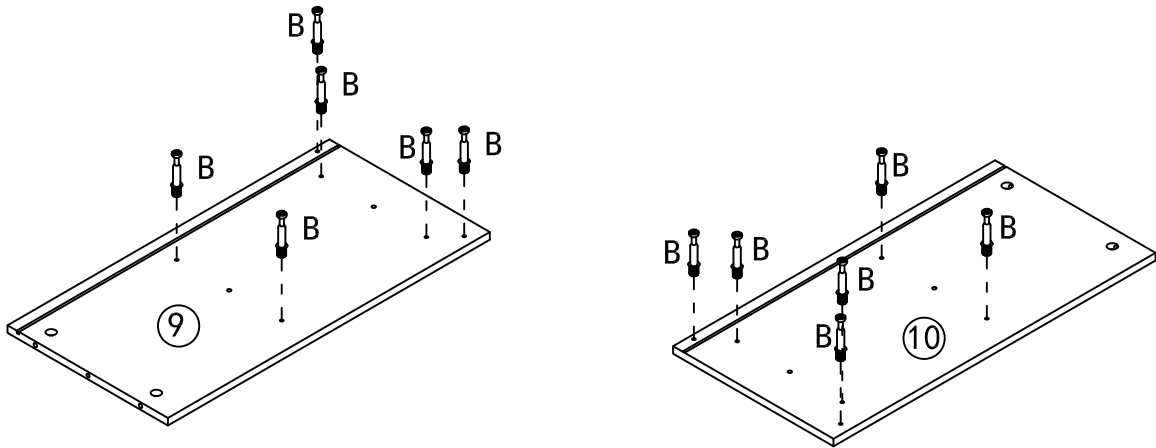

STEP 22

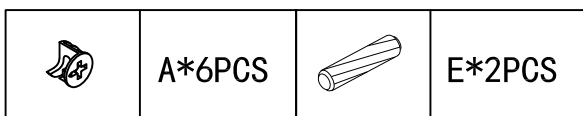
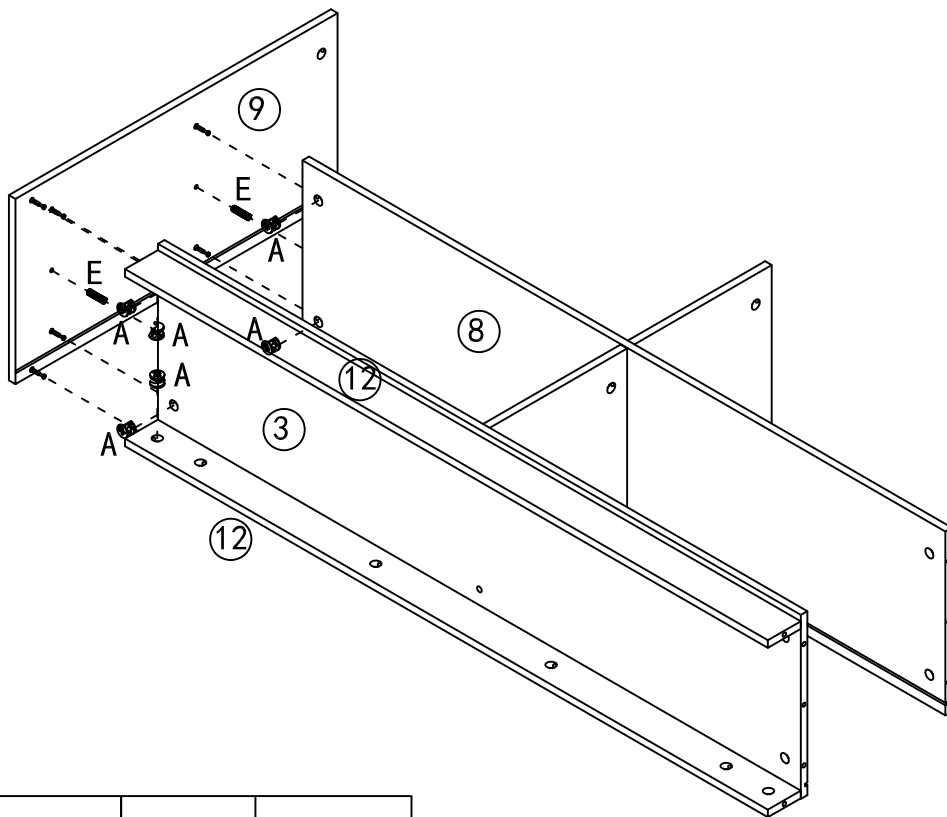

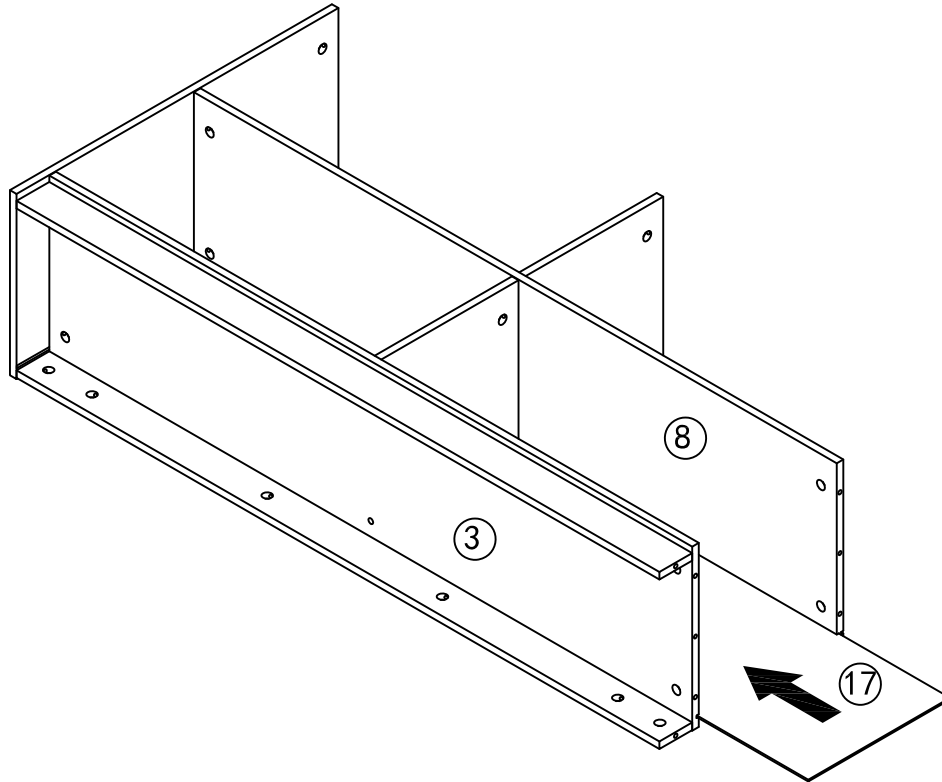

STEP 23

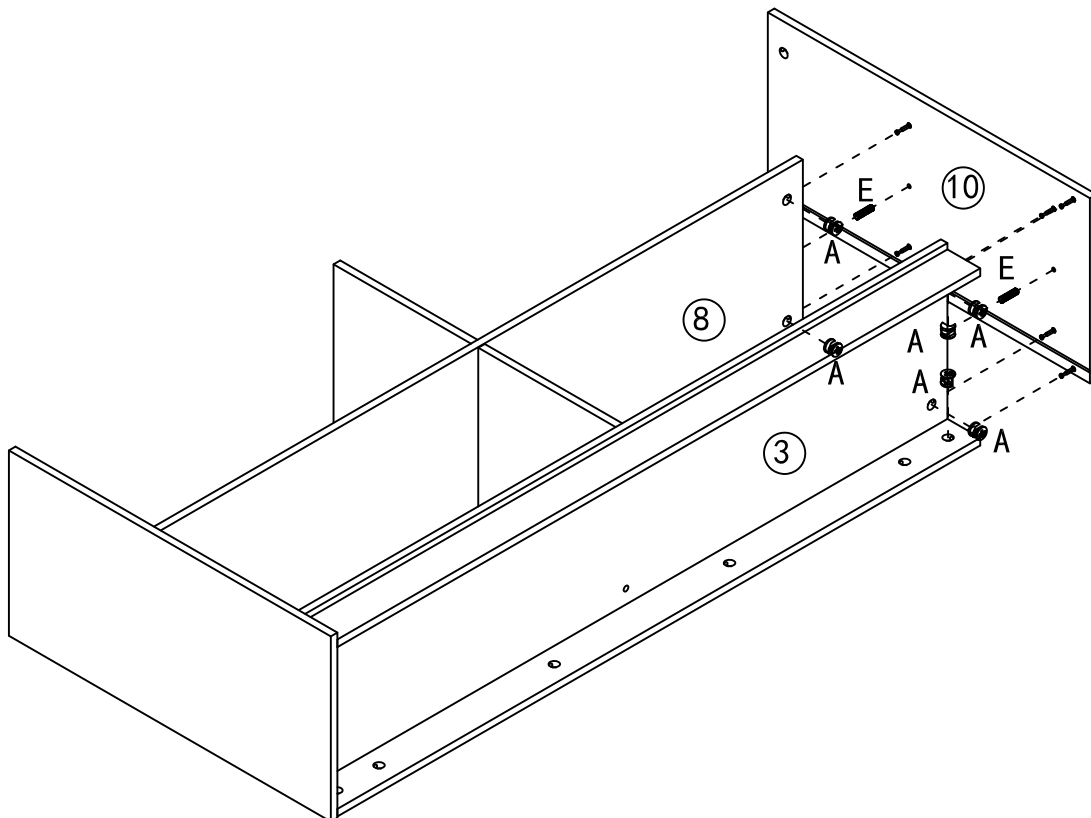

STEP 24



	A*6PCS		E*2PCS
---	--------	---	--------

STEP 25

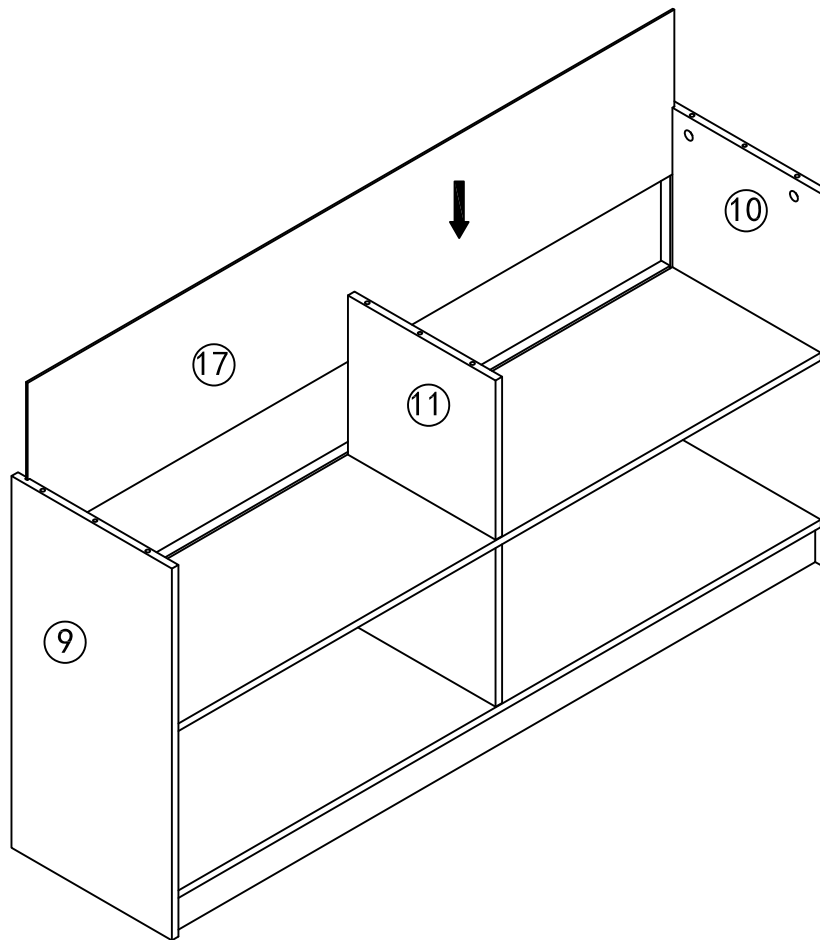

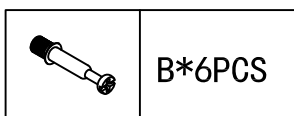
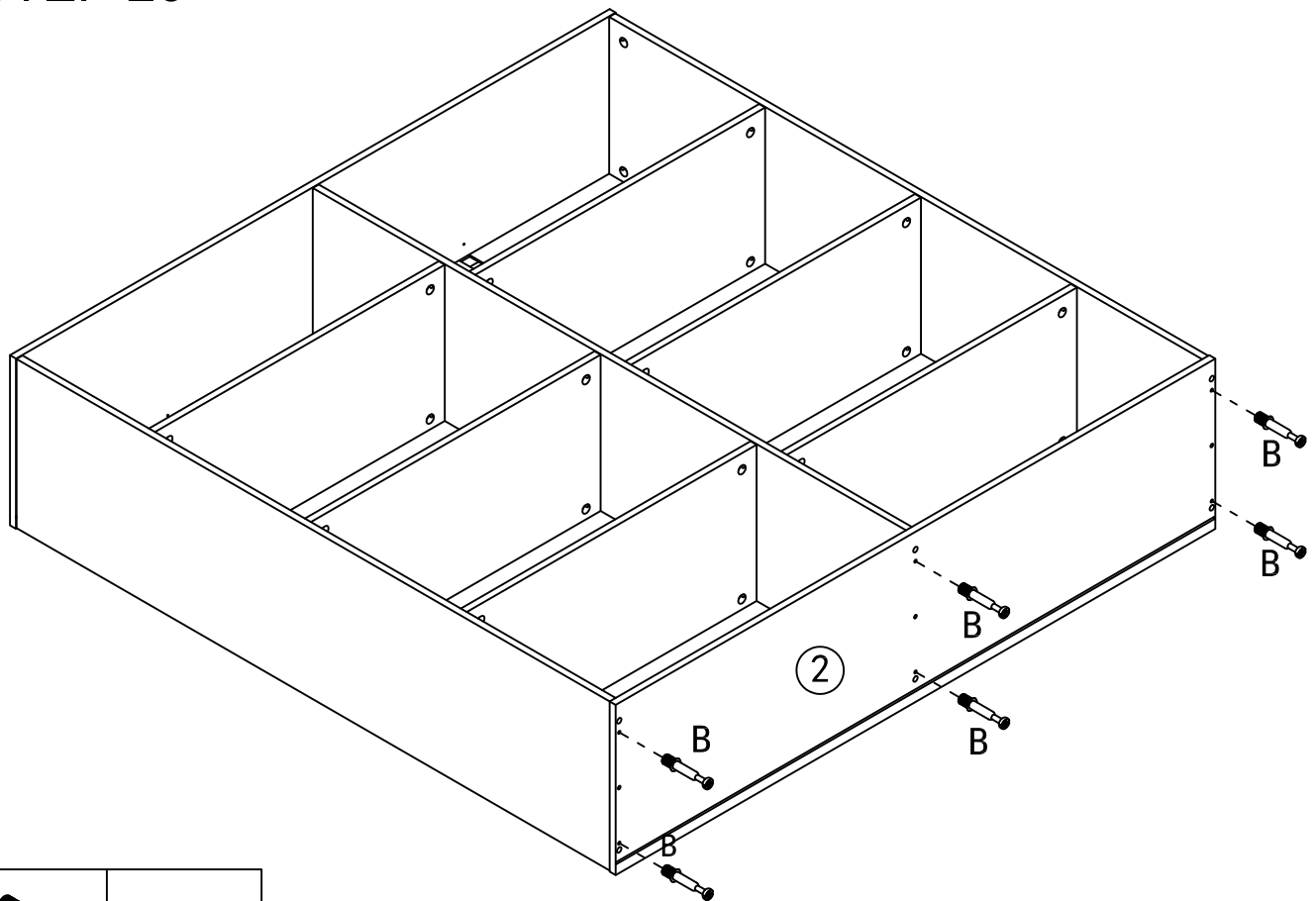

STEP 26



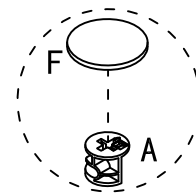
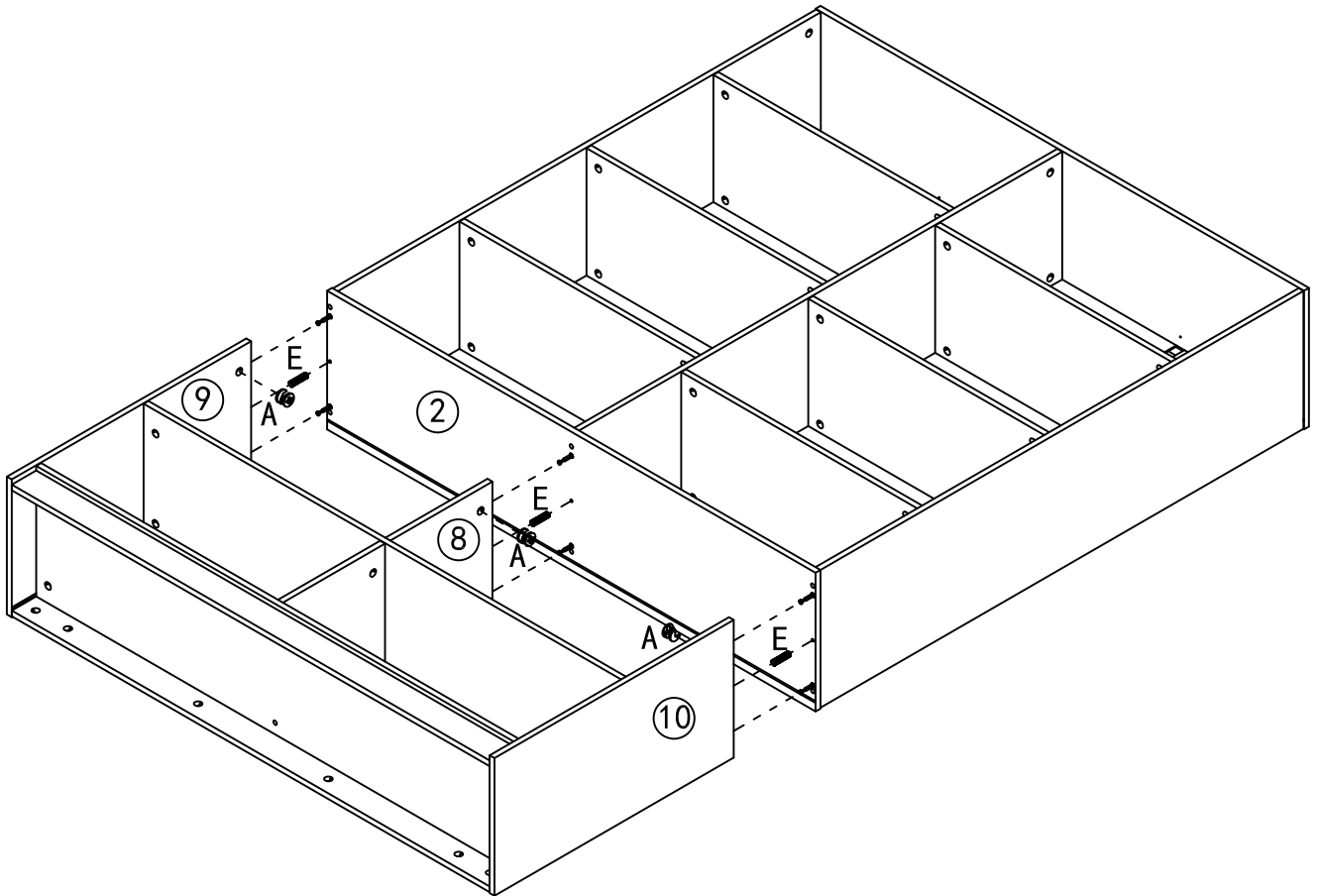

STEP 27



	A*6PCS		E*3PCS		F*6PCS
---	--------	---	--------	---	--------

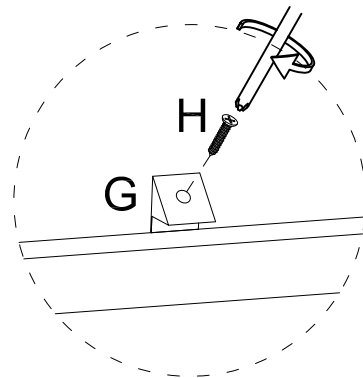
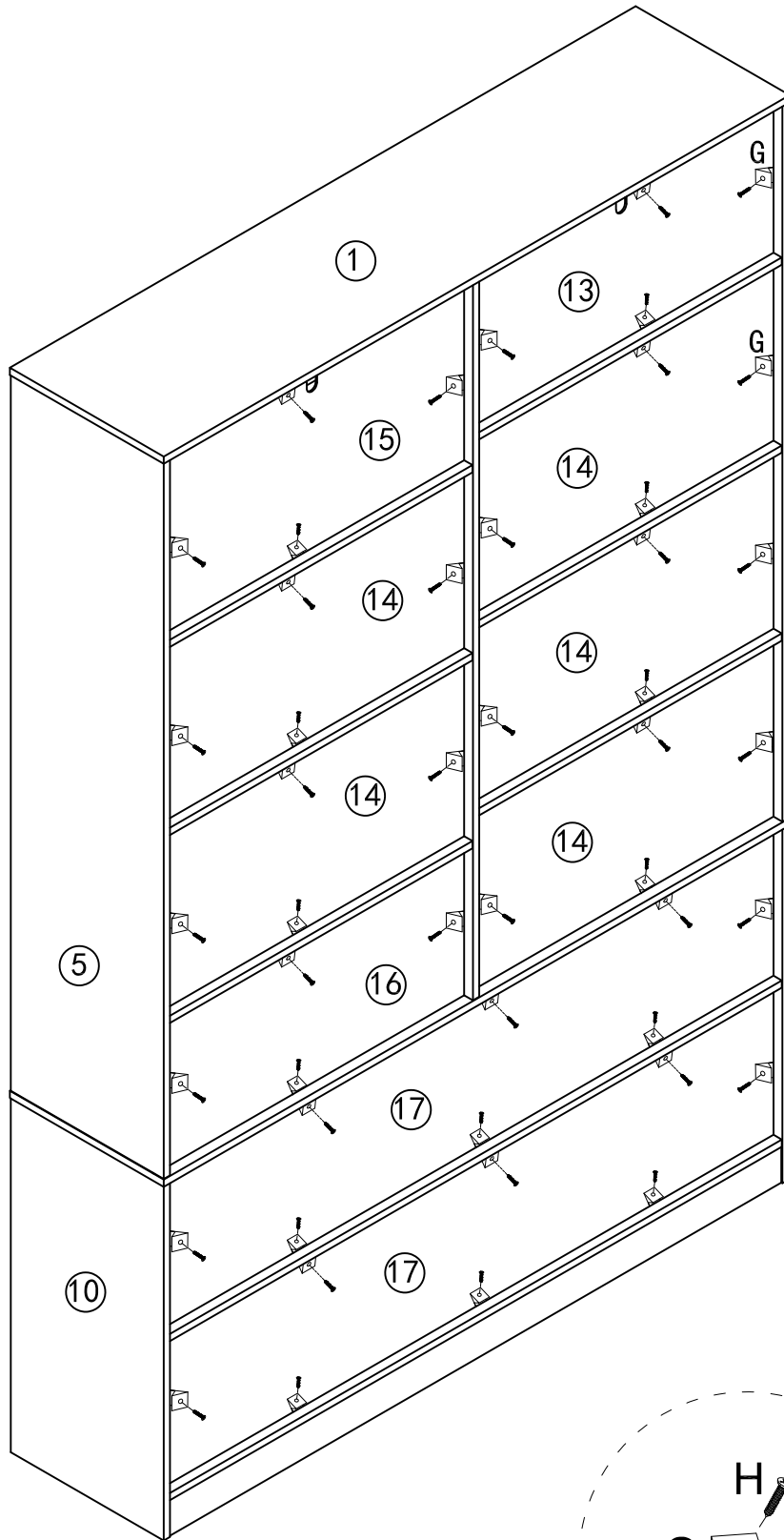

STEP 28

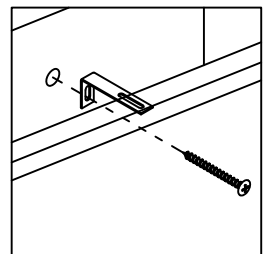
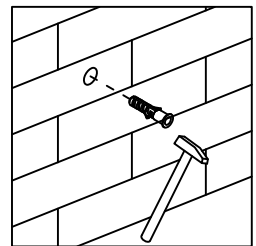
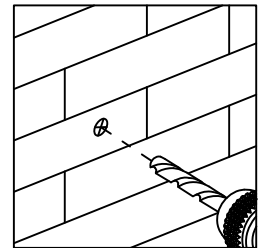
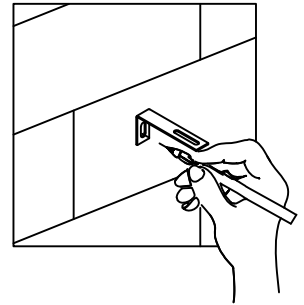
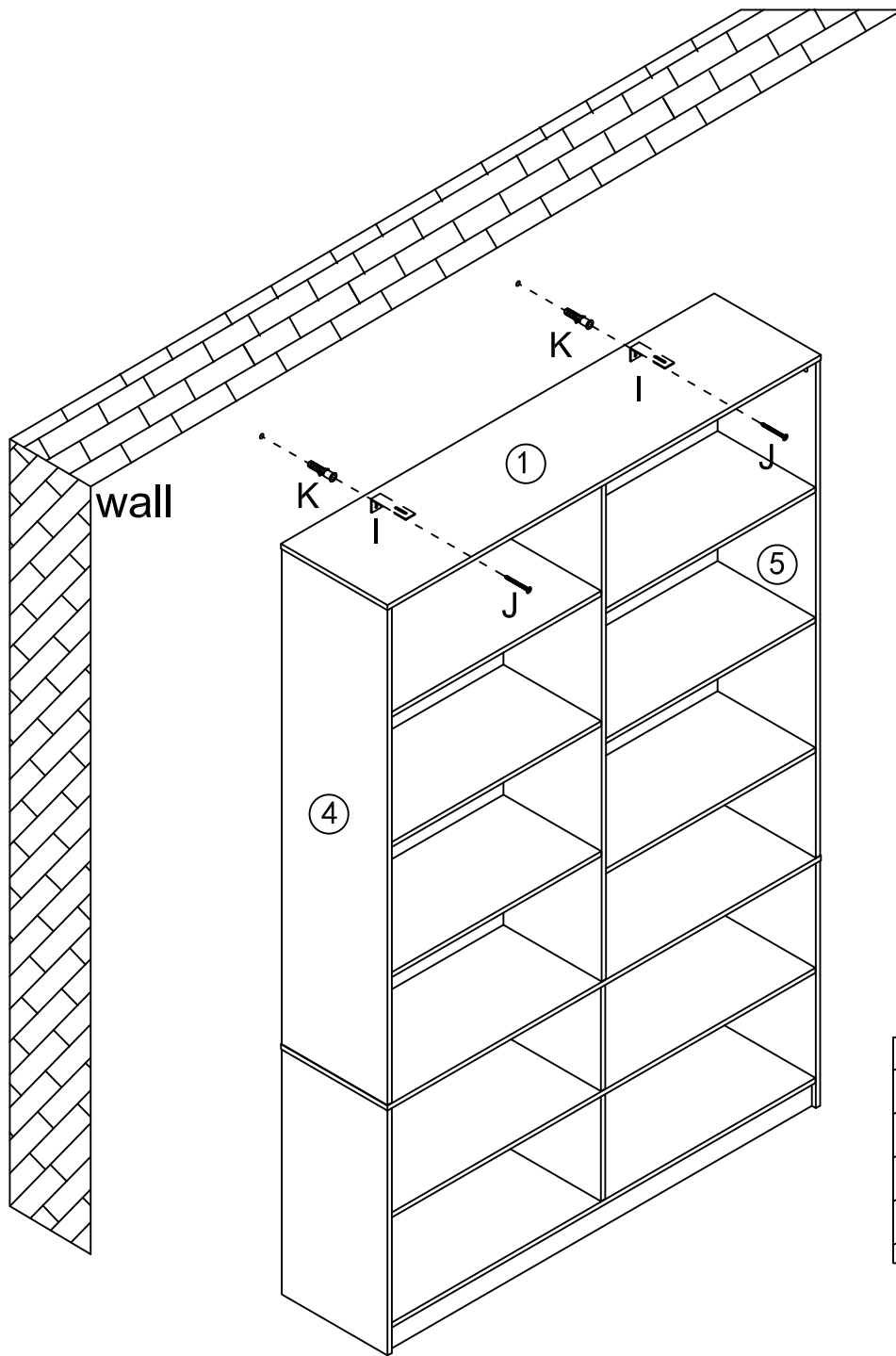

	G*48PCS		H*48PCS
---	---------	---	---------

STEP 29



	J*2PCS		K*2PCS
---	--------	---	--------