

ASSEMBLY INSTRUCTIONS



Fine Furniture for every stage of life

(B1&B2) *Eastern King Bed*

REVISION 0 : 11/26/2013
REVISION 1 : 08/28/2018
REVISION 2 : 01/02/2019
REVISION 3 : 07/05/2019

ASSEMBLY INSTRUCTIONS

ASSEMBLY TIPS:

1. Remove hardware from box and sort by size.
2. Please check to see that all hardware and parts are present prior to start of assembly.
3. Please follow attached instructions in the same sequence as numbered to assure fast & easy assembly.



WARNING!

1. Don't attempt to repair or modify parts that are broken or defective. Please contact the store immediately.
2. This product is for home use only and not intended for commercial establishments.







ASSEMBLY TIME

20 MINUTES

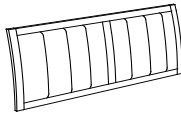
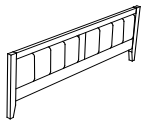
PARTS IDENTIFICATION

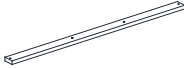
B1 (BOX 1)



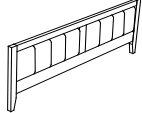
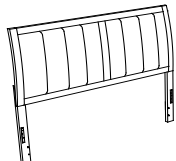

A	HEADBOARD PANEL		1PC	D	FOOTBOARD		1PC
B	RIGHT HEADBOARD LEG		1PC	E	BED SLAT		4PCS
C	LEFT HEADBOARD LEG		1PC	F	BED SLAT SUPPORT WITH LEVELER		8PCS

B2 (BOX 2)

G	BED RAIL		2PCS	D	FOOTBOARD		1PC
HB	HEADBOARD COMPLETE		1PC				

HARDWARE IDENTIFICATION

Z-B1 (BOX 1) - HARDWARE PACK IS LOCATED IN (B1)

1	BOLT (M6 x 35mm - BLK)		6PCS	4	ALLEN WRENCH (M4 x 60mm - BLK)		1PC
2	LOCK WASHER (1/4" - BLK)		6PCS	5	FLAT HEAD SCREW (M4 x 32mm - RBW)		8PCS
3	FLAT WASHER (1/4"ID x 13mm - BLK)		6PCS				

NOTE:

Phillips head screw driver is required in the assembly process; however, manufacturer does not provide this item.

ASSEMBLY INSTRUCTIONS

STEP 1

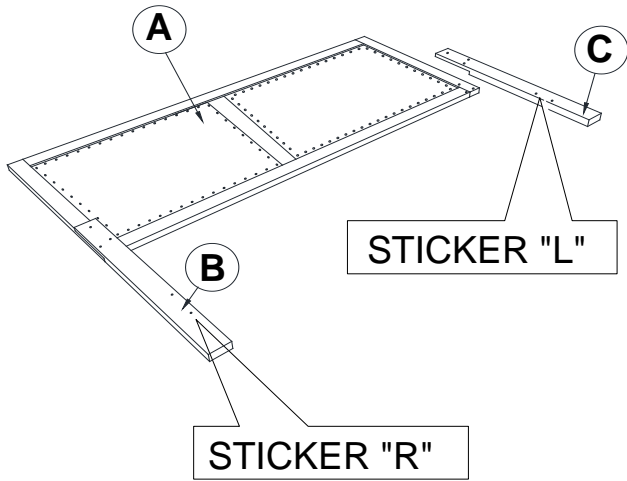

****BACK VIEW****

Note: Please take note of the marking sticker (L & R) on the headboard legs.

STEP 2

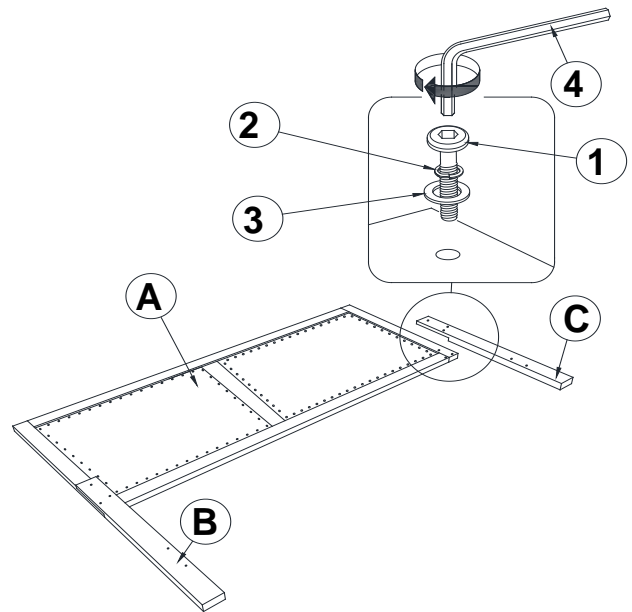

****BACK VIEW****

STEP 3

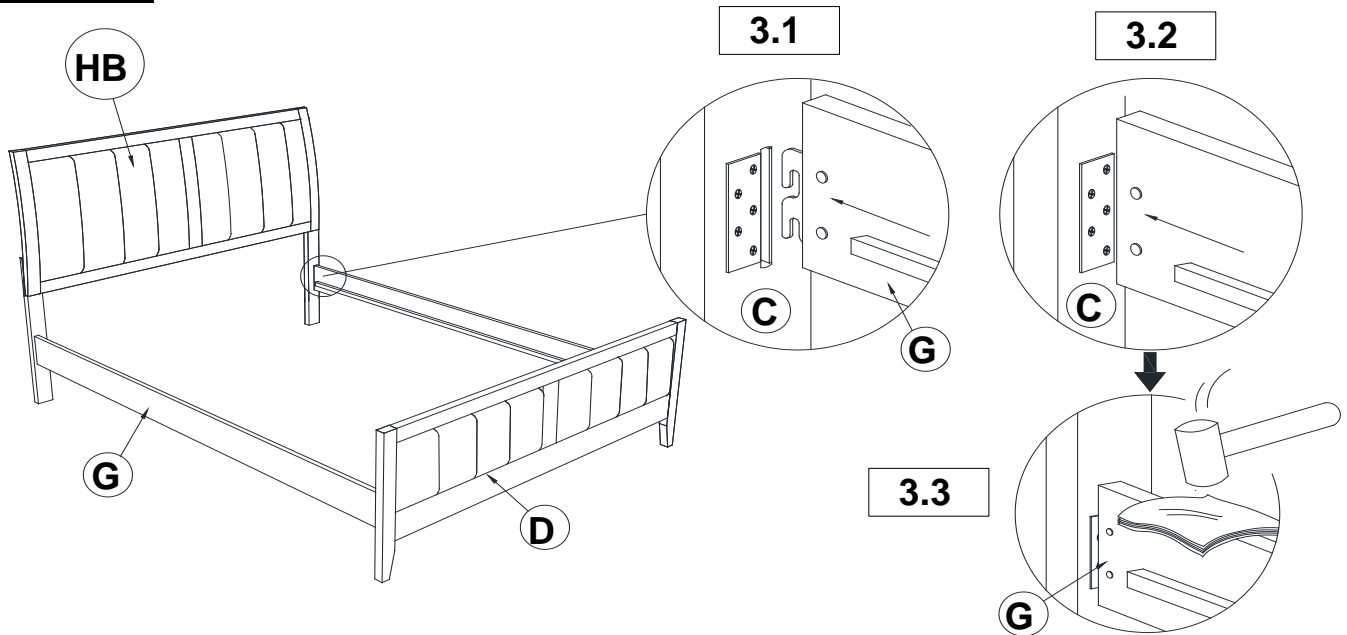

ASSEMBLY INSTRUCTIONS

STEP 4

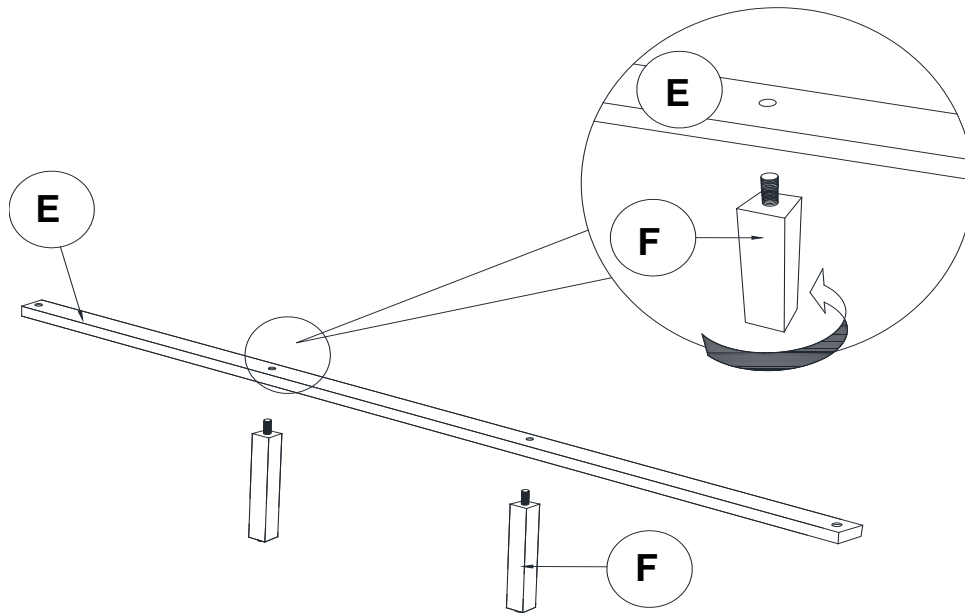

STEP 5

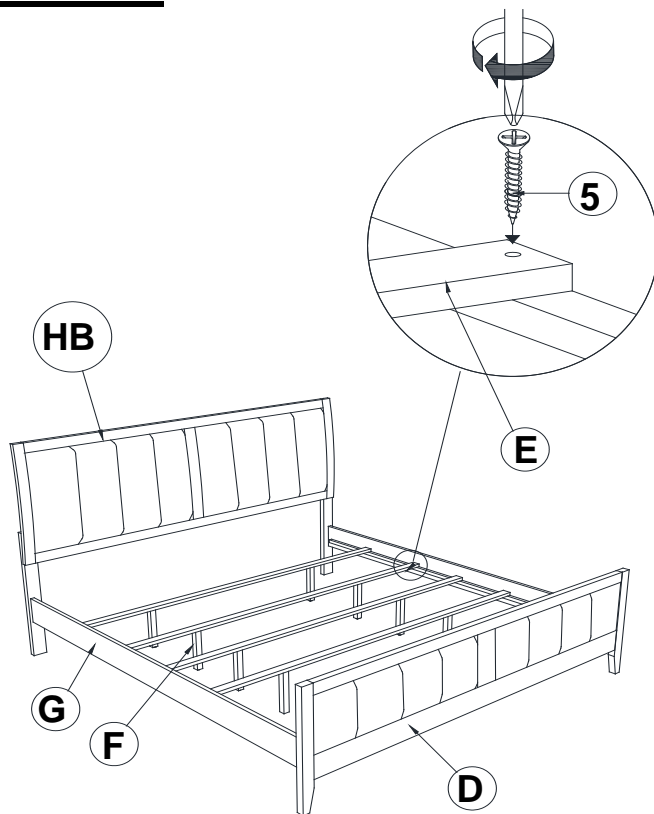

STEP 6 **COMPLETE**

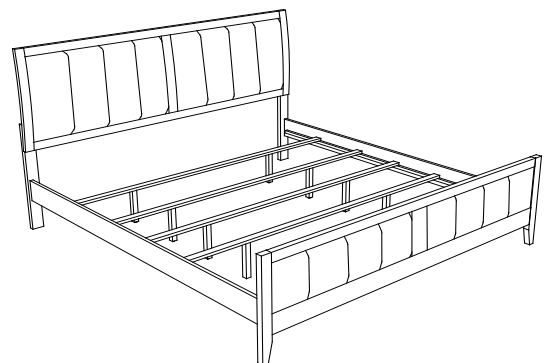

Inner Size : 76.75"W x 81.00"D

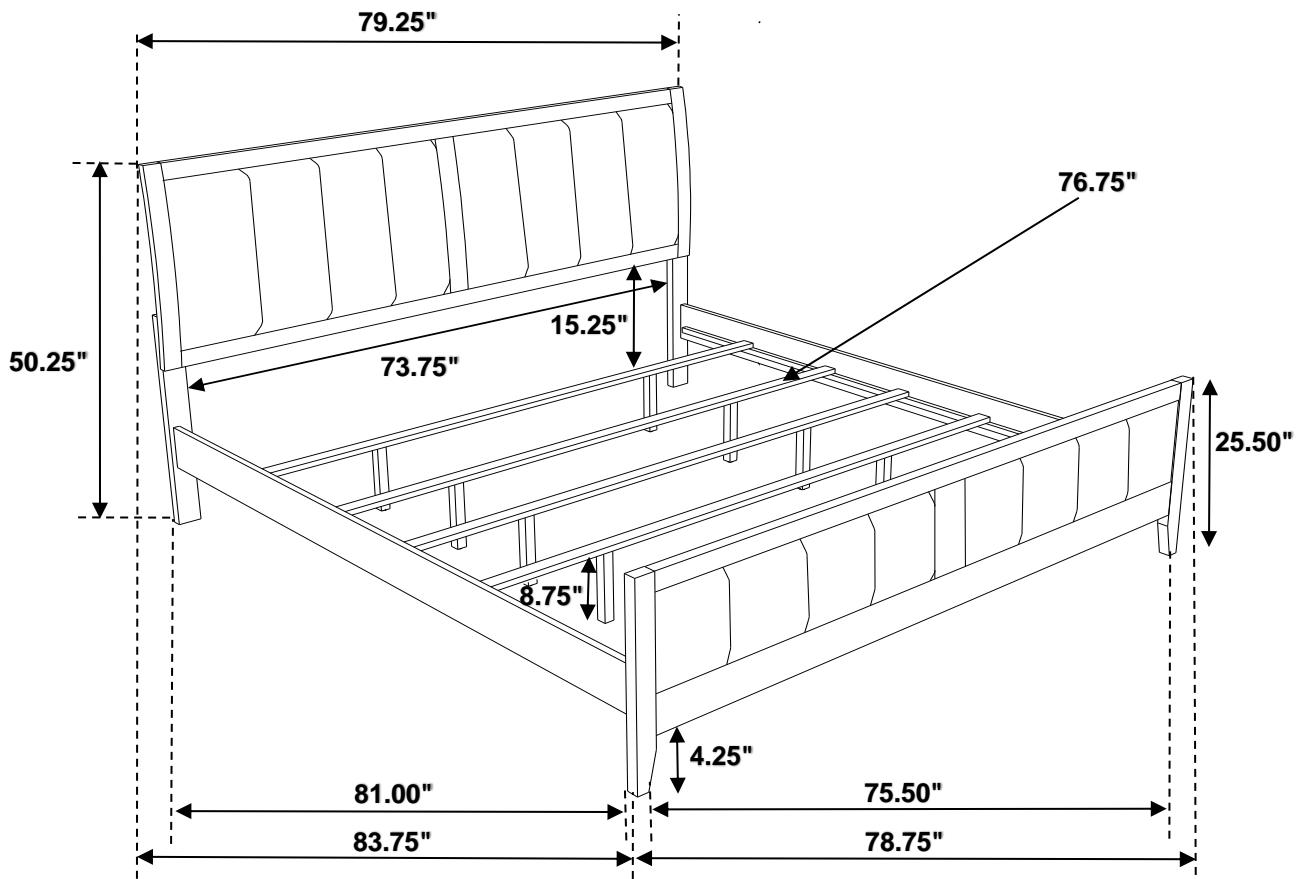

Note: Dimension tolerance $\pm 5\%$