

ASSEMBLY INSTRUCTION

MODEL : (QUEEN BED 60"x80")

Before you begin, please read Assembly Instruction carefully and recognized the part and hardware. Then follow them step by step.

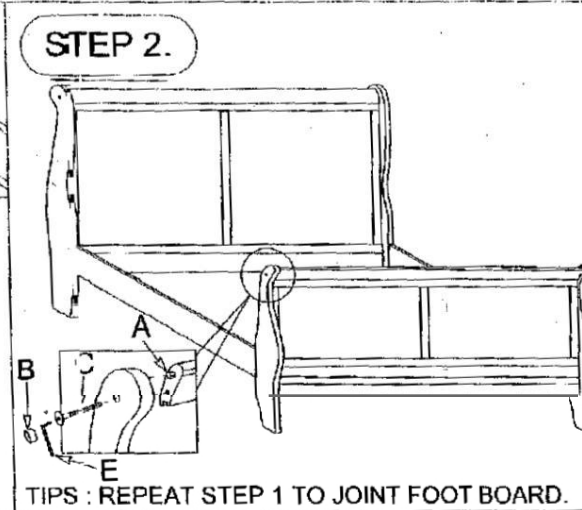
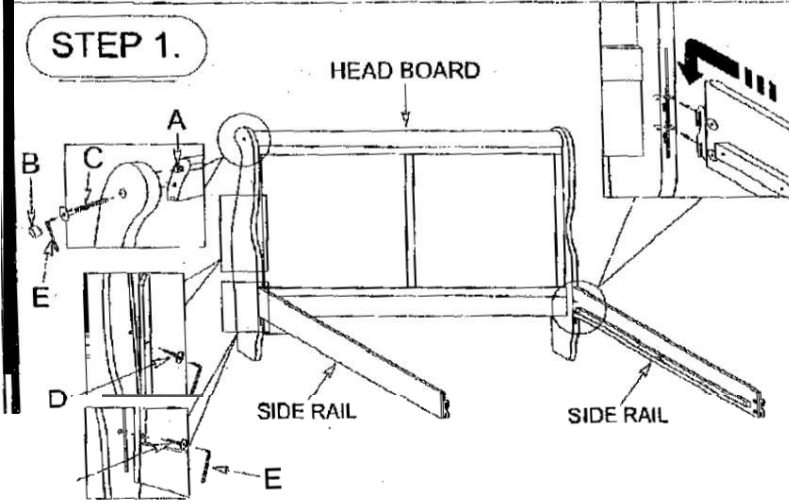

HARDWARE PART 1

| NO | HARDWARE DESCRIPTION | QTY |
|----|-----------------------|------|
| A. | Wood Dowel M12 x 50mm | 4PCS |
| B. | Wood Bolton M15 x 9mm | 4PCS |
| | | 4PCS |
| | | 8PCS |
| | | 1PC |

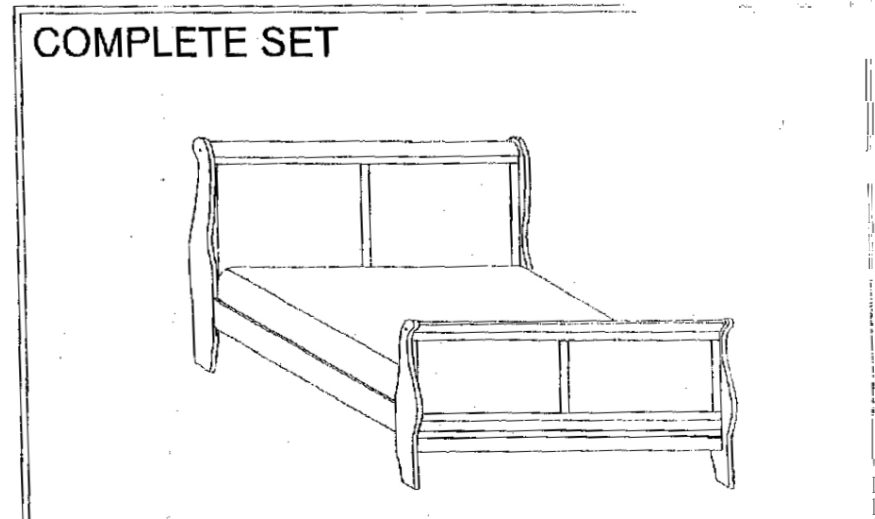
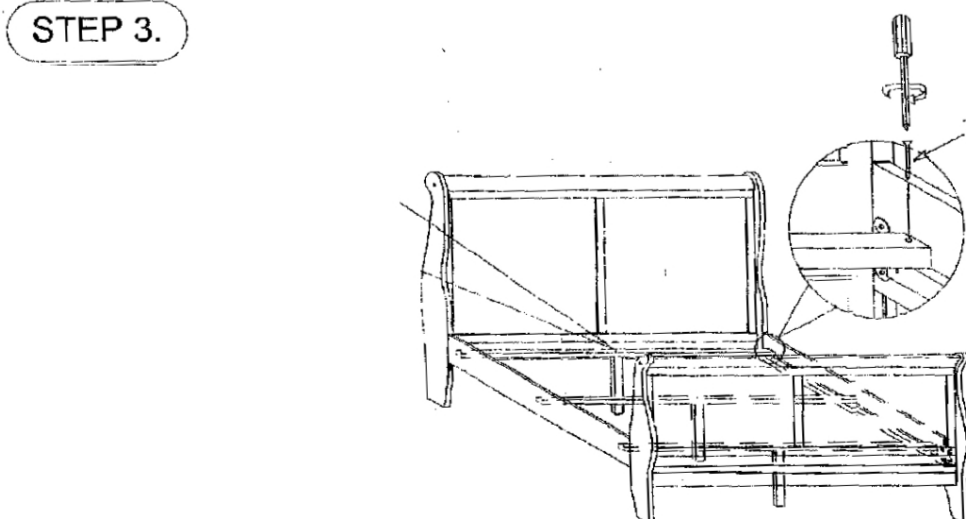

* TOTAL SLAT: 3PCS (WITH JCBC HOLE)+ 3PCS (SLATS SUPPORT)

