







## CARE AND MAINTENANCE

Dust with a dry cloth. Do not use abrasive cleaner. Use glass cleaner to clean surface of table top.

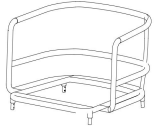
## NOTICE

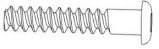
- \* Please make sure that you have all parts indicated before you begin assembly of this item
- \* This item should be assembled on a soft surface to prevent scratching the finish during assembly
- \* This item may require periodic tightening

## Part List and Hardware List

PIECE	DESCRIPTION		QUANTITY
A	Seat Part		1X
B	Front Leg-L		2X
C	Rear Leg-S		2X
H1	Screw		8X
H2	Spring Washer		8X
H3	Flat Washer		8X
H4	Allen Key		1X

Product Dimensions: W25.2xD24.4"D x 29"H

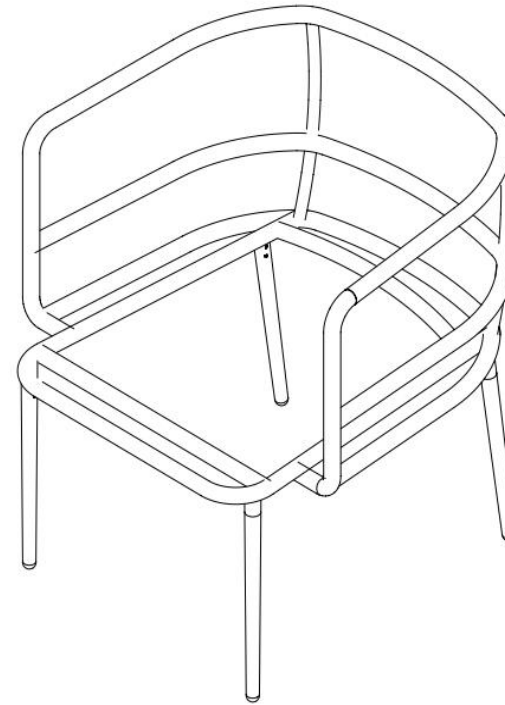

## PREPARATION

Before beginning assembly of product, make sure all parts are present. Compare parts with package contents list and hardware contents list.

If any part is missing or damaged, do not attempt to assemble the product.

Estimated Assembly Time: 8 minutes.

Tools Required for Assembly (included): Allen Key

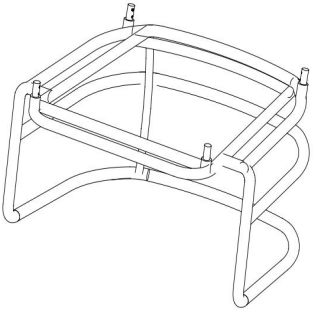
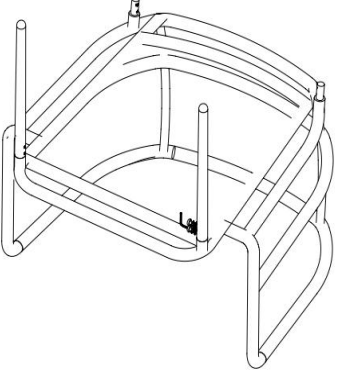
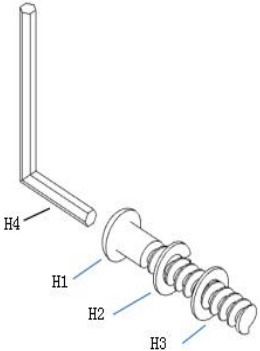
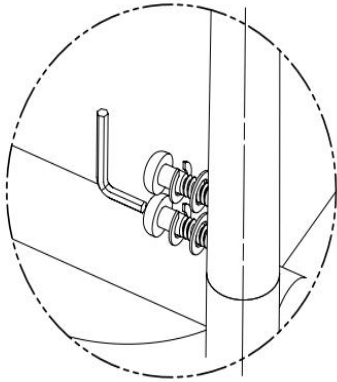
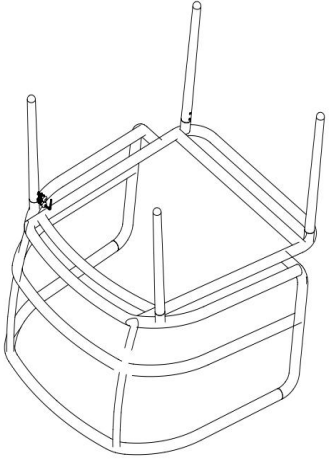
		
<p><b>STEP1</b> PLACE SEAT PART (A) FACE DOWN ON A SMOOTH SURFACE</p>	<p><b>STEP2</b> INVERT FRONT LEGS (B) AND ALIGN HOLE TO THREAD OPENING OF SEAT PART (A)</p>	<p><b>STEP3</b> PUT THE WASHERS ON THE BOLT IN THE ORDER SHOWN IN THE PICTURE</p>
		
<p><b>STEP4</b> USE SCREW (H1) AND SECURE BOLTS (H4) TIGHTLY</p>	<p><b>STEP5</b> REPEAT STEPS 3-4 FOR THE REAR LEGS ( B ) AS INDICATED IN PICTURE ABOVE</p>	