

Oversized Chaise Lounge Sofa

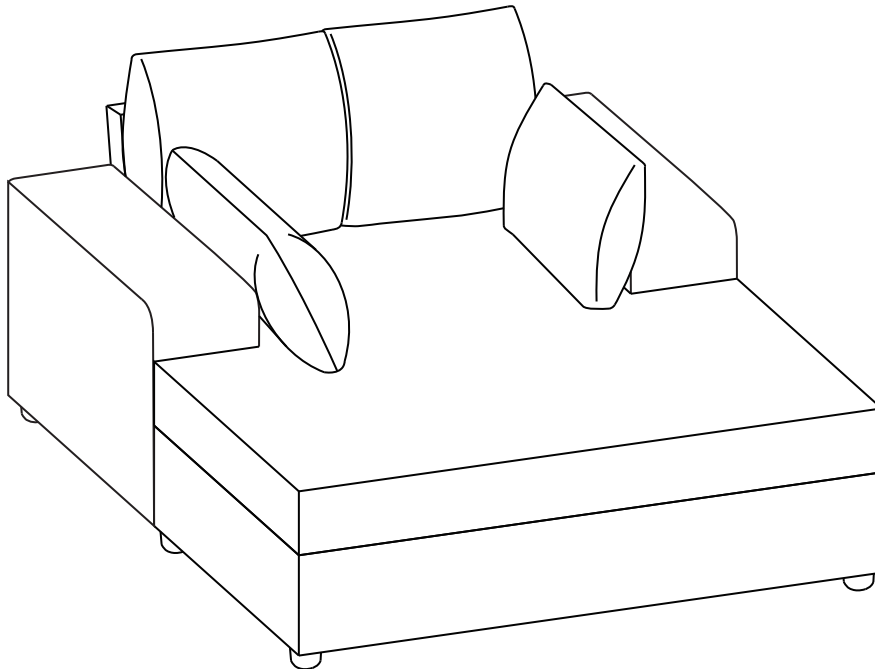

NOTICE

Please keep these instructions for future reference.

● Thank you for your purchase. When you receive the product, please make sure that all the parts are intact. If any parts are missing, please contact us promptly to request replacement parts.

● Then follow the entire installation instructions to install.

● Each part is crucial, so please be careful not to lose any. It is recommended to store parts with different lettered identifiers in separate boxes or bags to avoid confusion during installation.

A . The outer box is damaged

B . The product is damaged / bent / cracked while you open the box

C . The parts / accessories / assembly tools are missing

D . The instructions are not clear and can not be referred

E . The product has functional problems

F . Other aspects that you are not satisfied with

Please feel free to contact us for help.

PART LIST

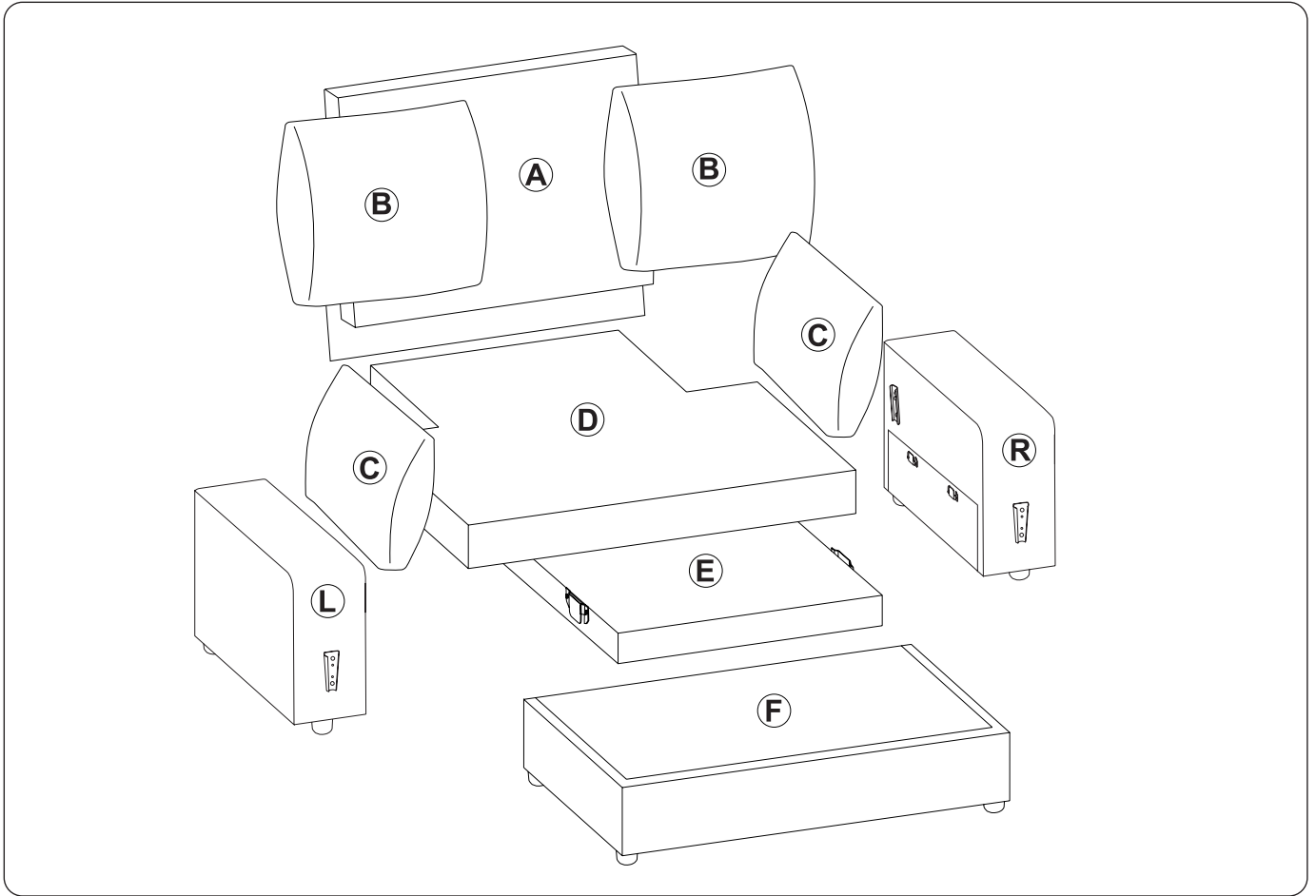

Hardware parts

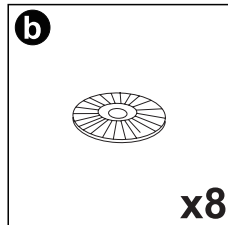
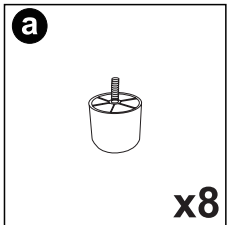

Main structure accessories

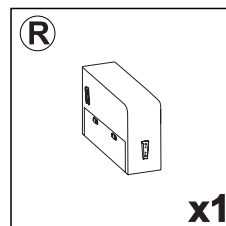
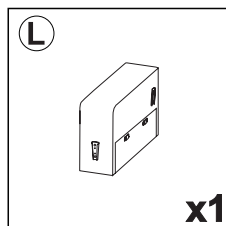
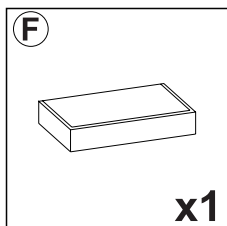
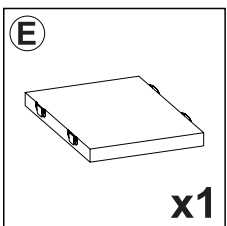
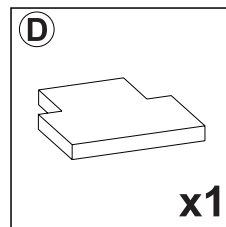
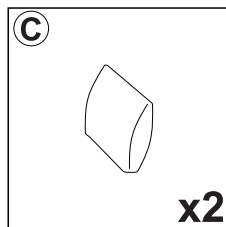
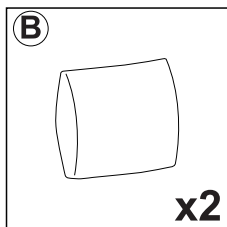
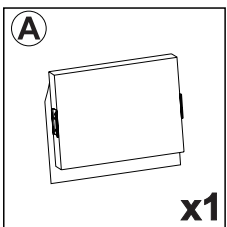

STEP

1

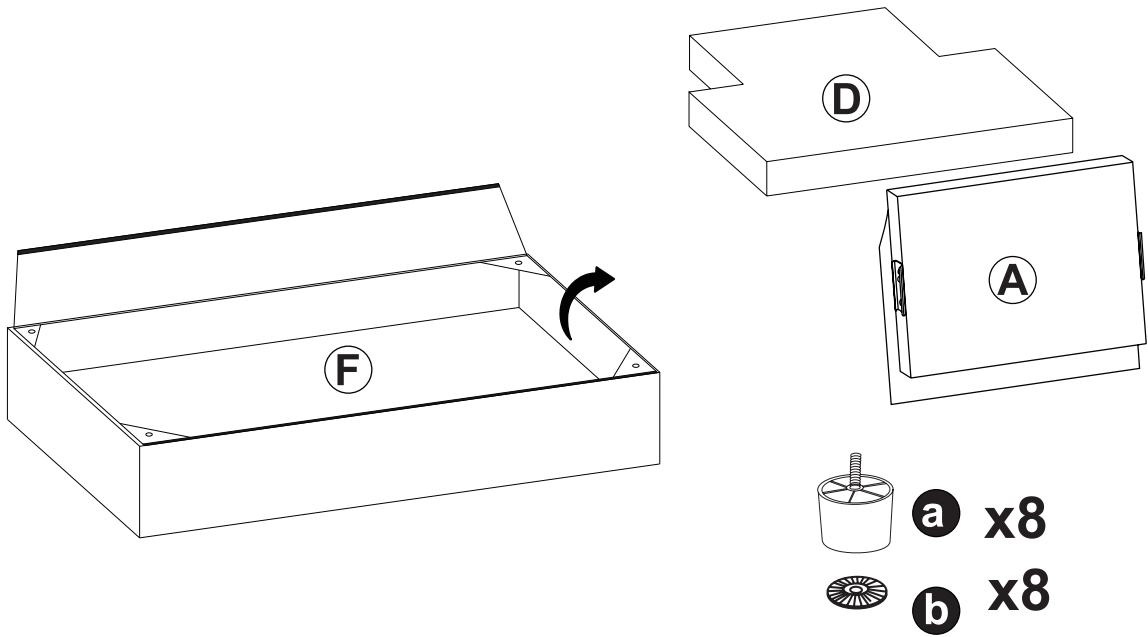

2 **!** Note: The pillows are inside the armrests.

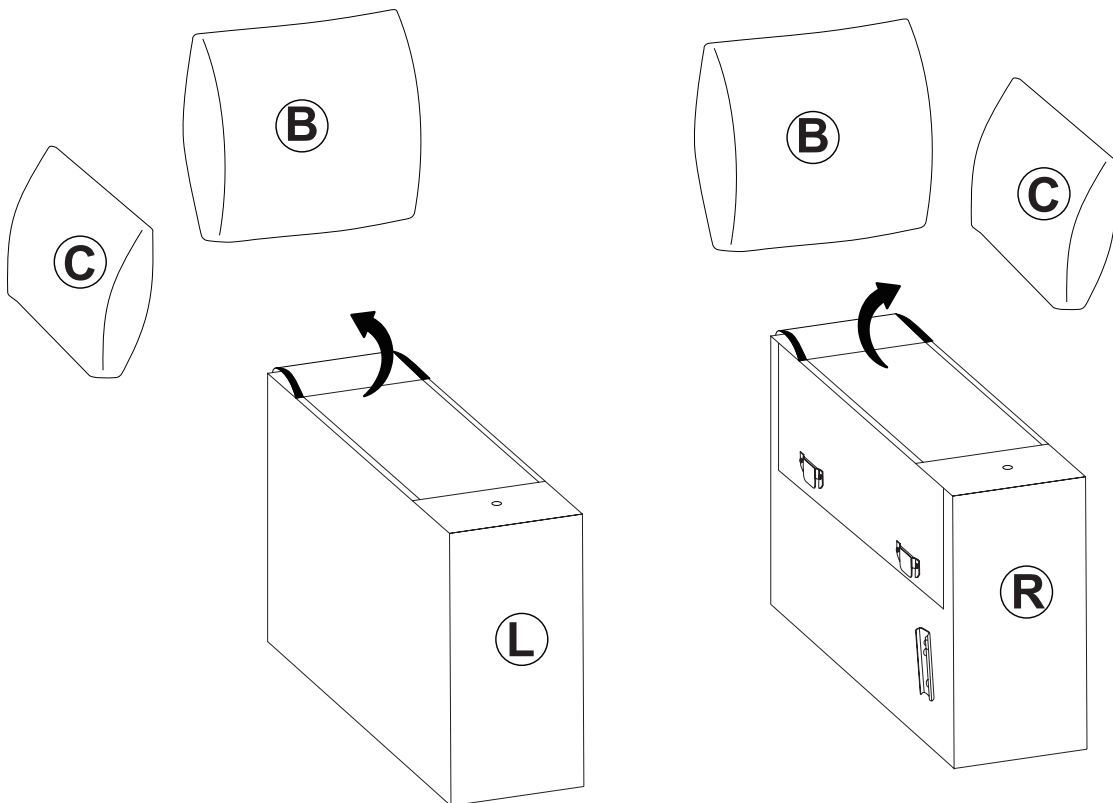

2

STEP

3

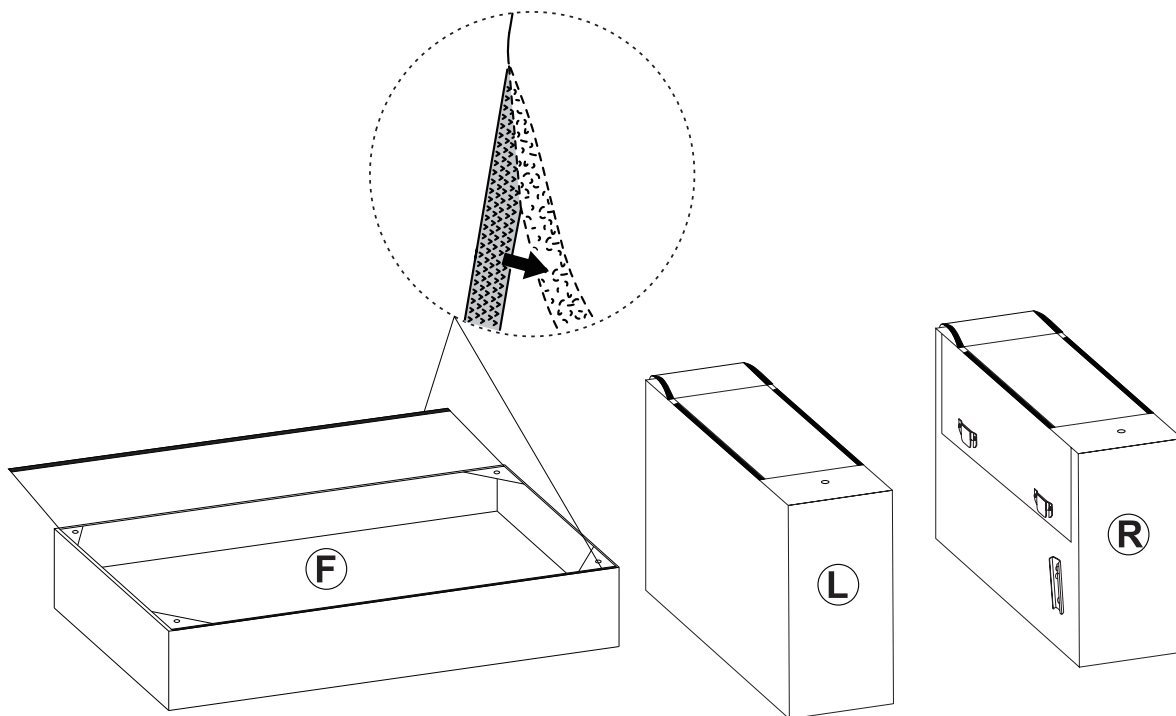

4

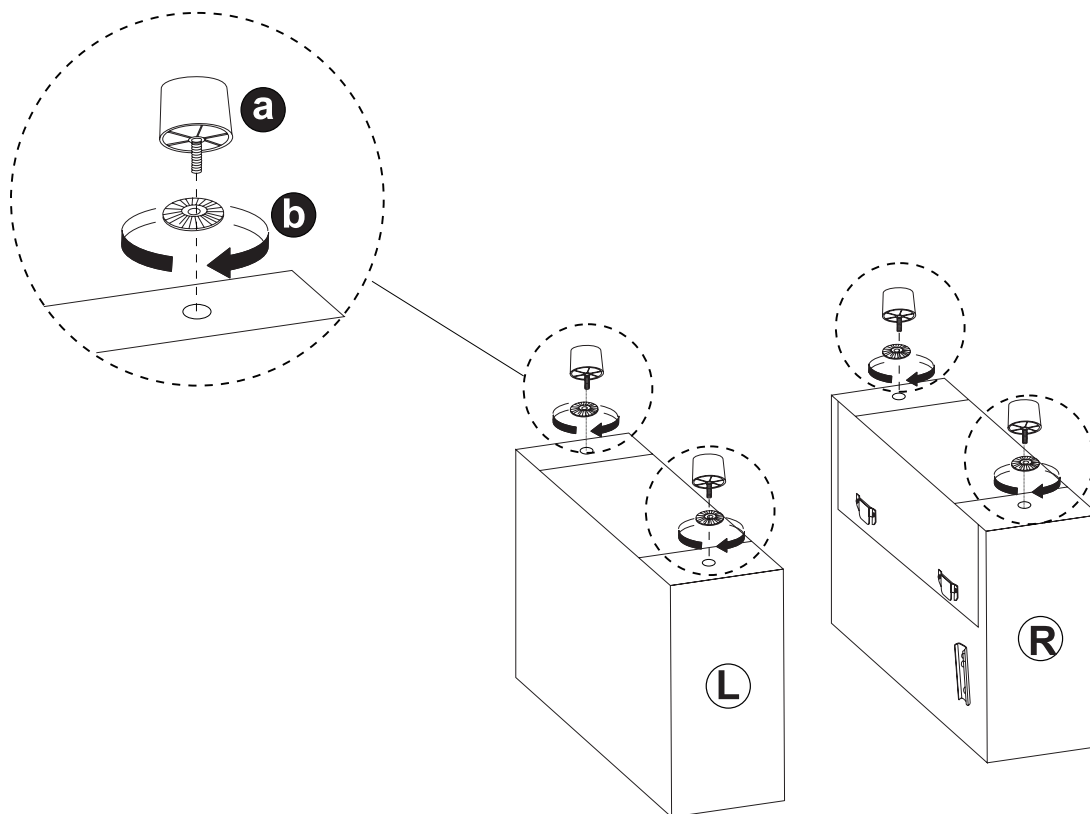

3

STEP

5

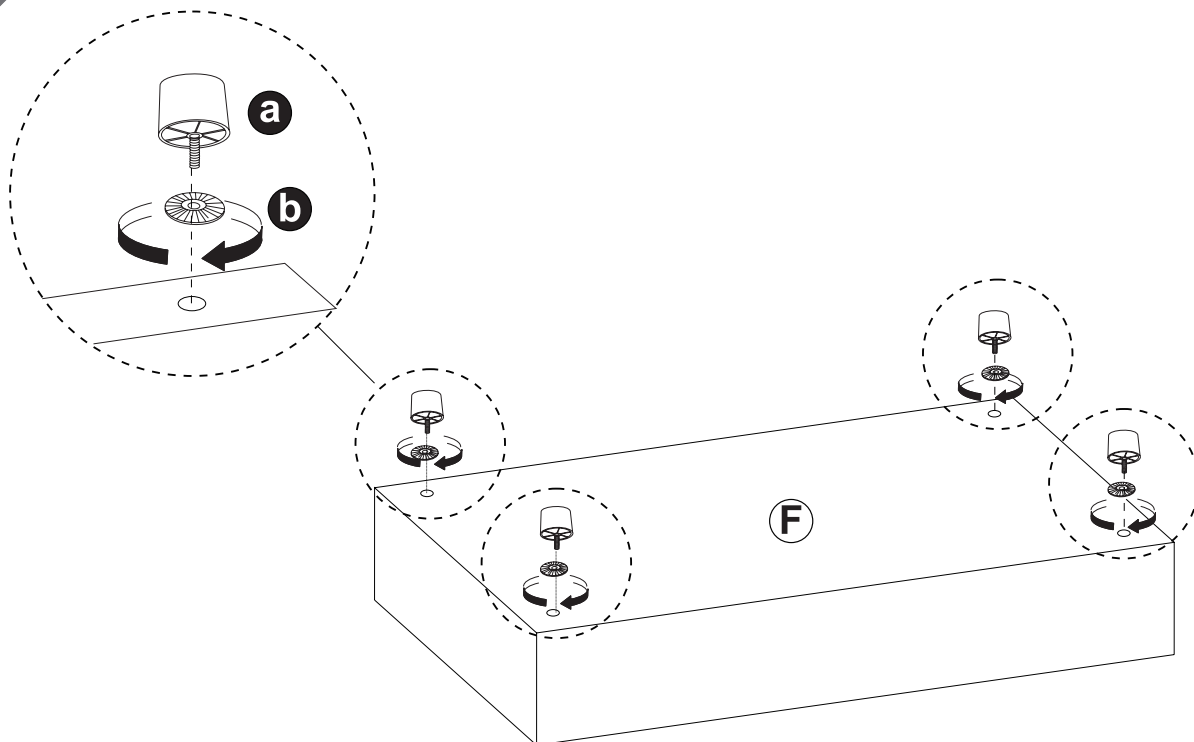

6

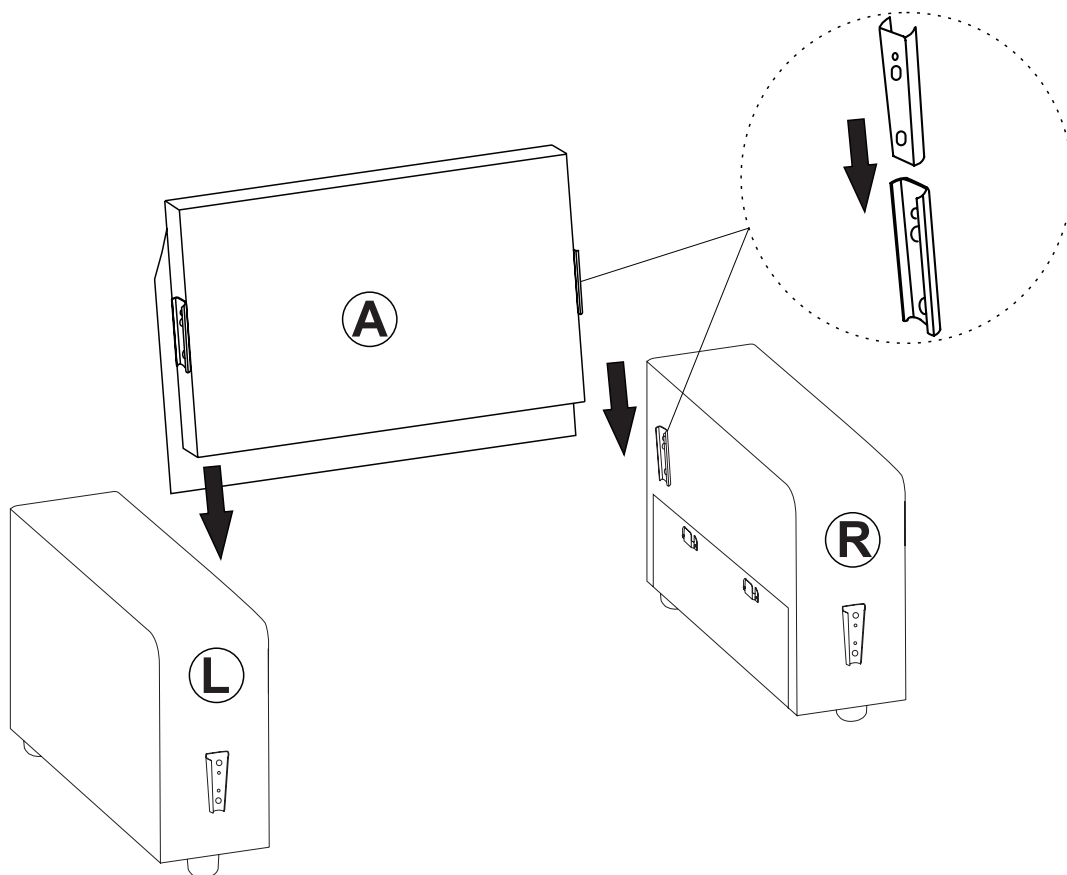

4

STEP

7

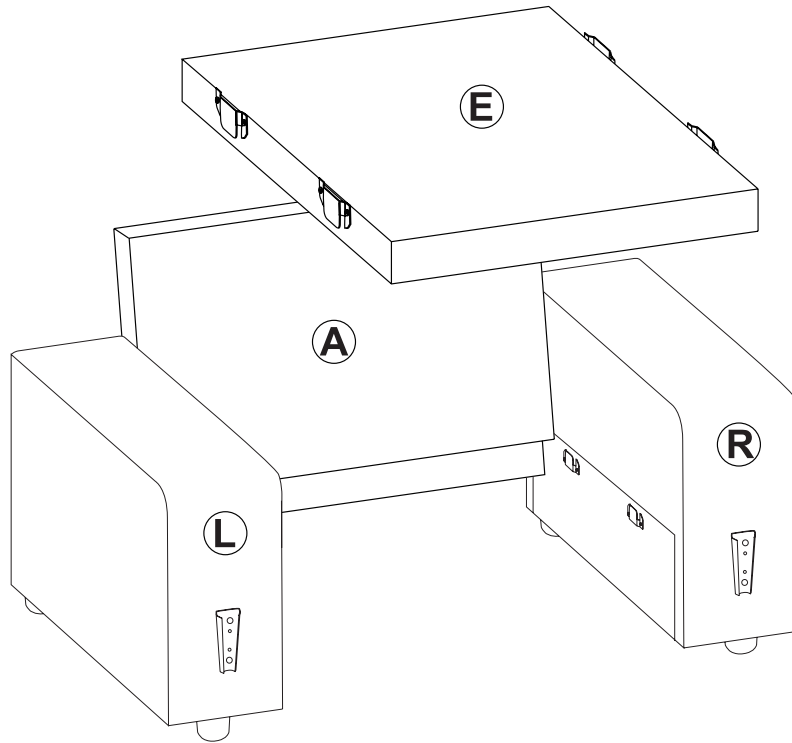

8

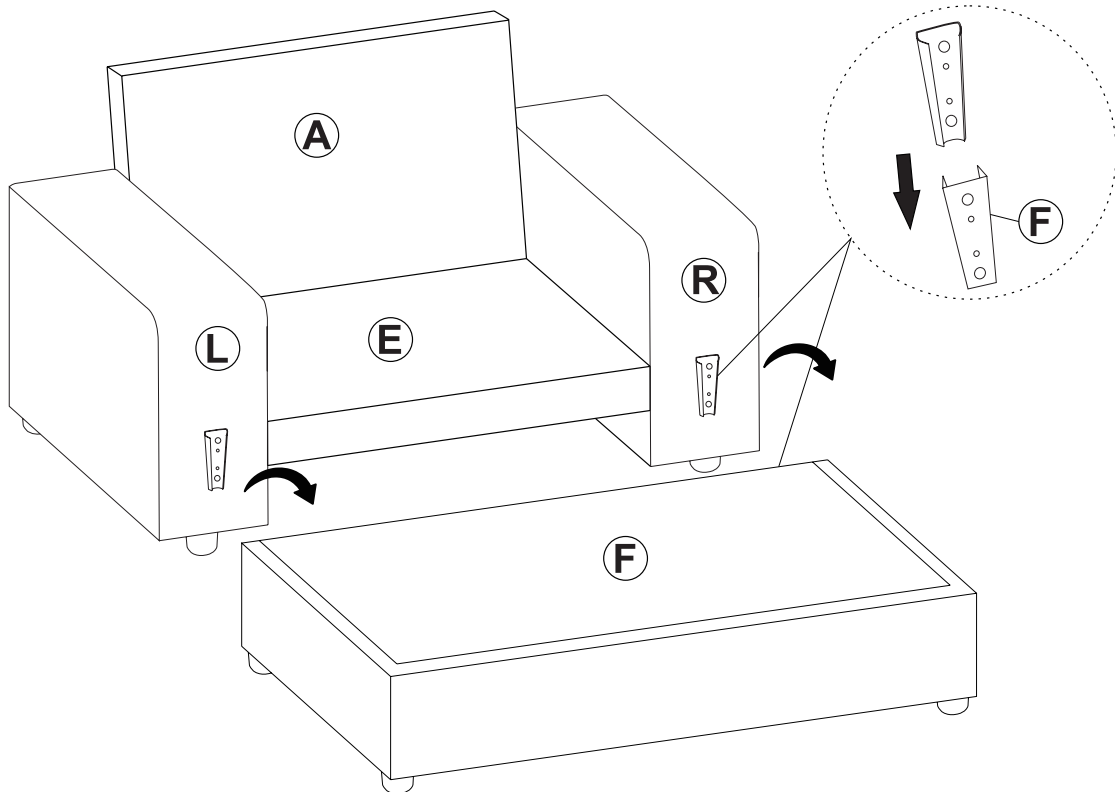

5

STEP

9

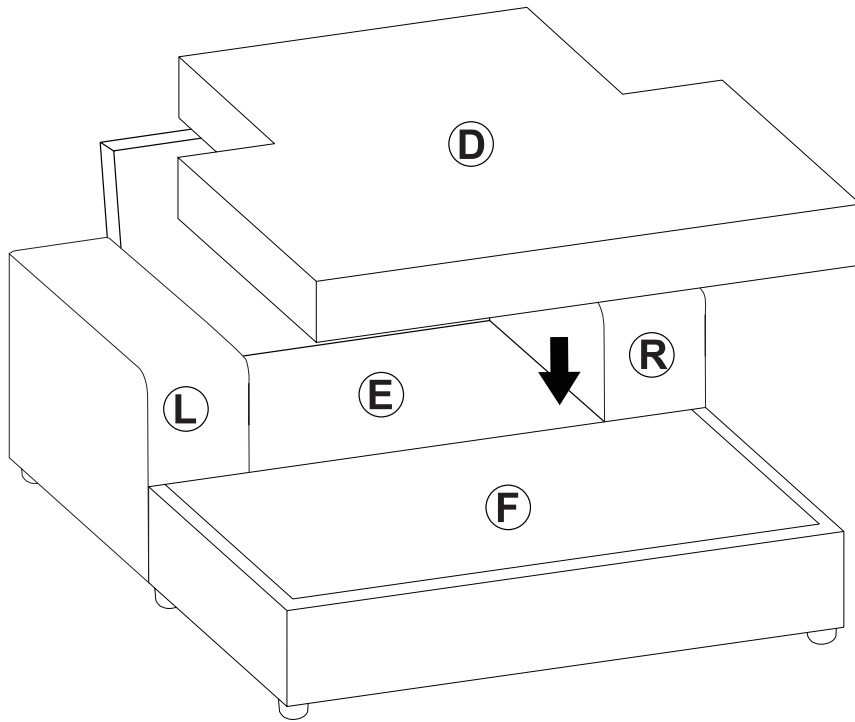

10

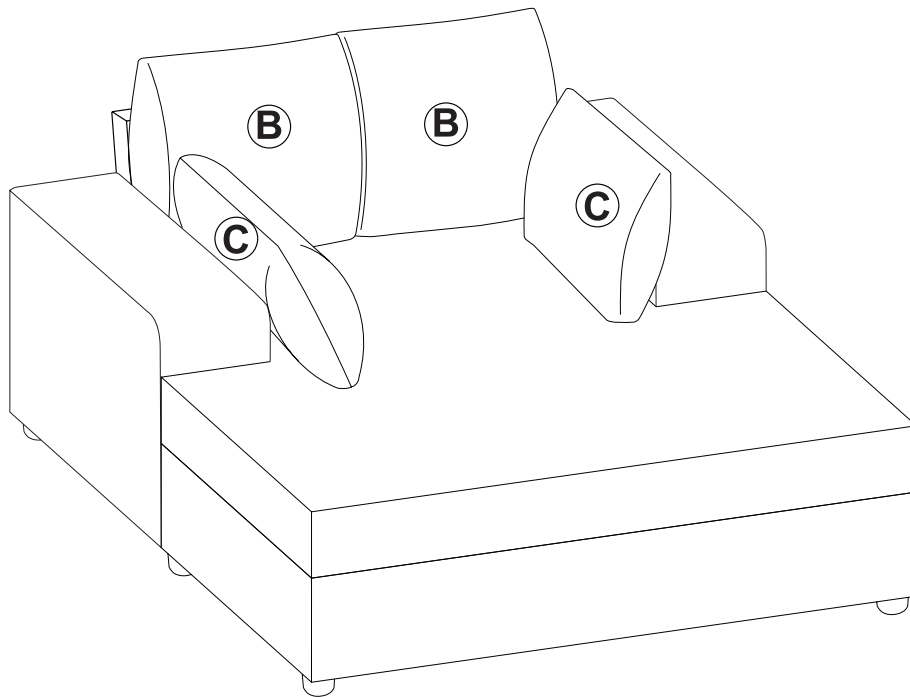

STEP

11

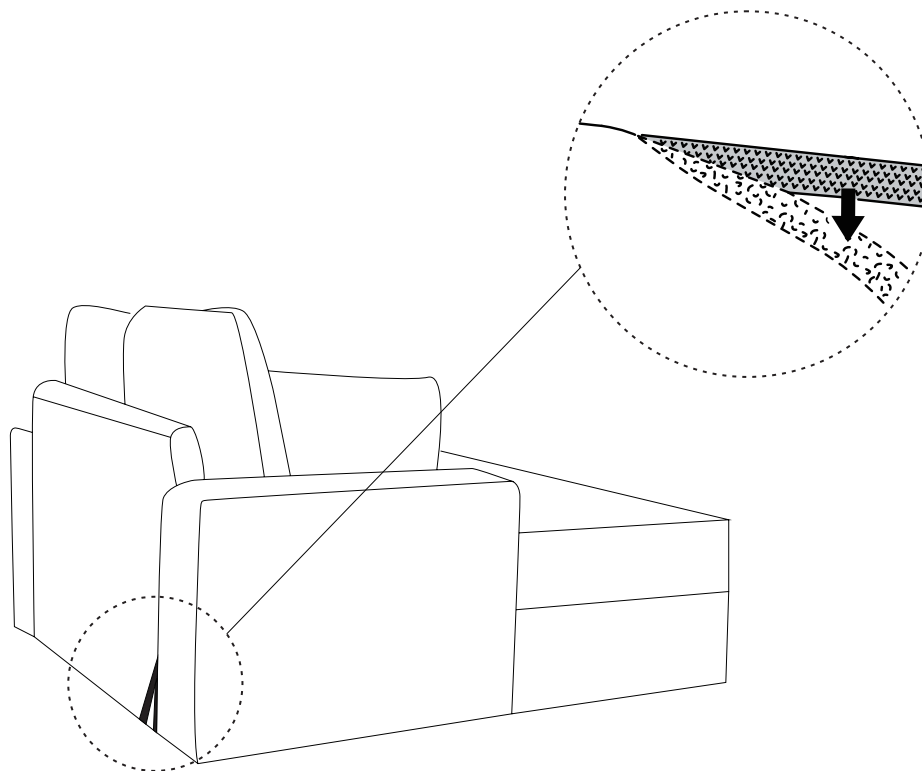

12

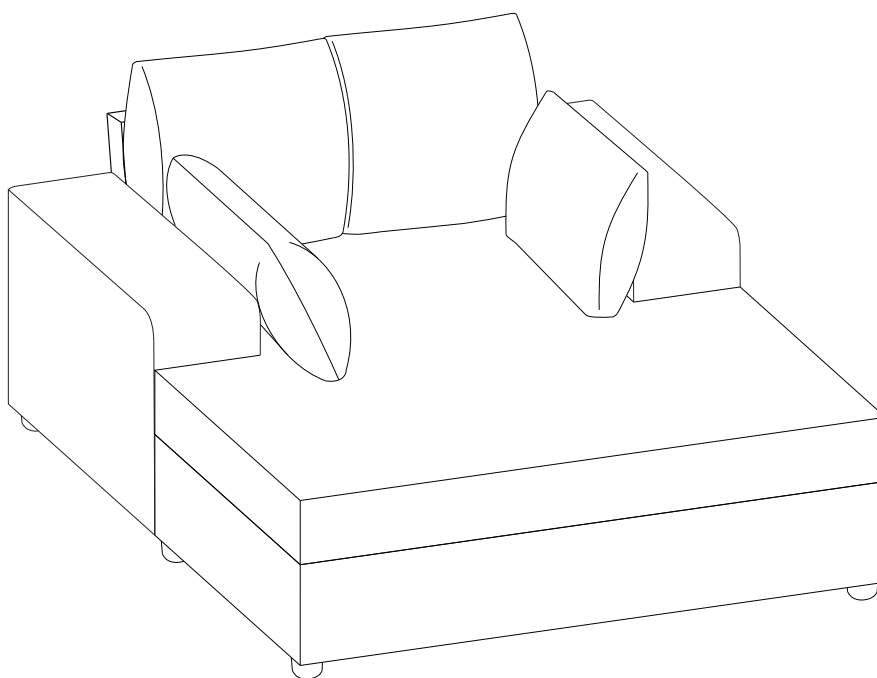

AFTER-SALE SERVICE

If you have any suggestions for our products or find that the products have quality problems, please contact us first, our after-sales team will reply you within 24 hours, and we will do our best to give you solutions until you are satisfied.

Guaranteed Customer Service

Your shopping experience is very important to us!
Feel unsatisfied? **Contact us!**
Have any questions? **Contact us!**

Wanna share how wonderful our smart products make your home?

Share your pictures with us.
Any suggestions? **Contact us!**
We will check and give feedback!