

# ASSEMBLY INSTRUCTION

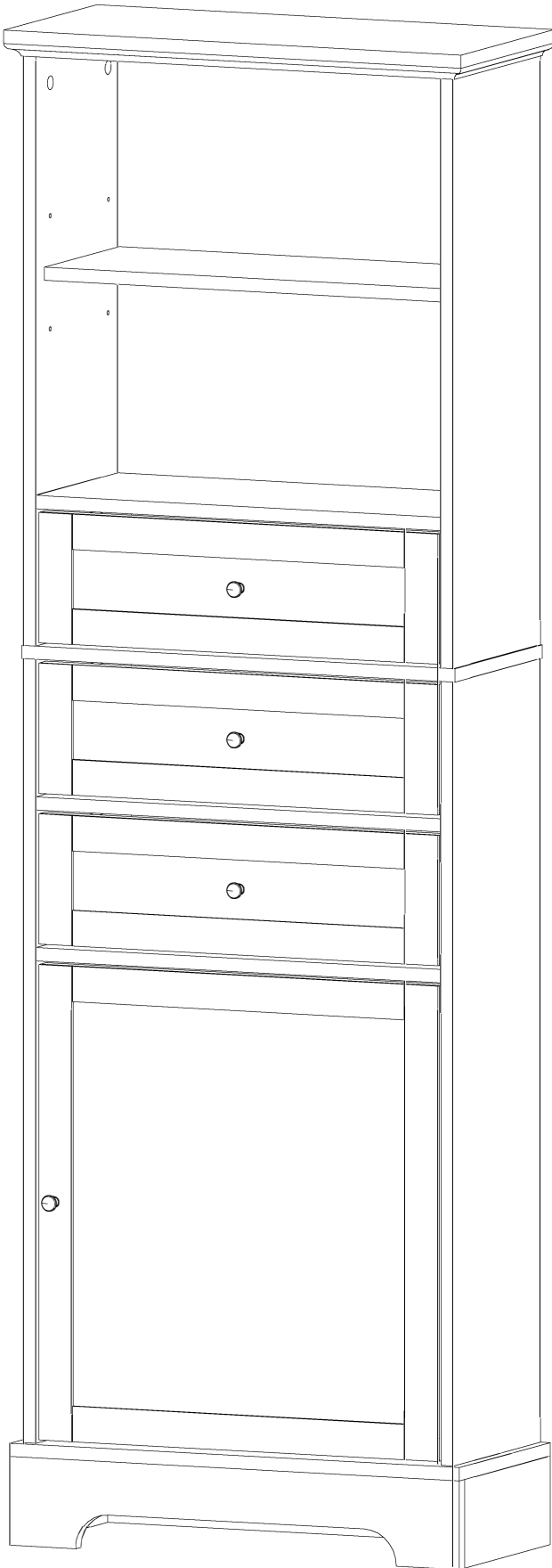

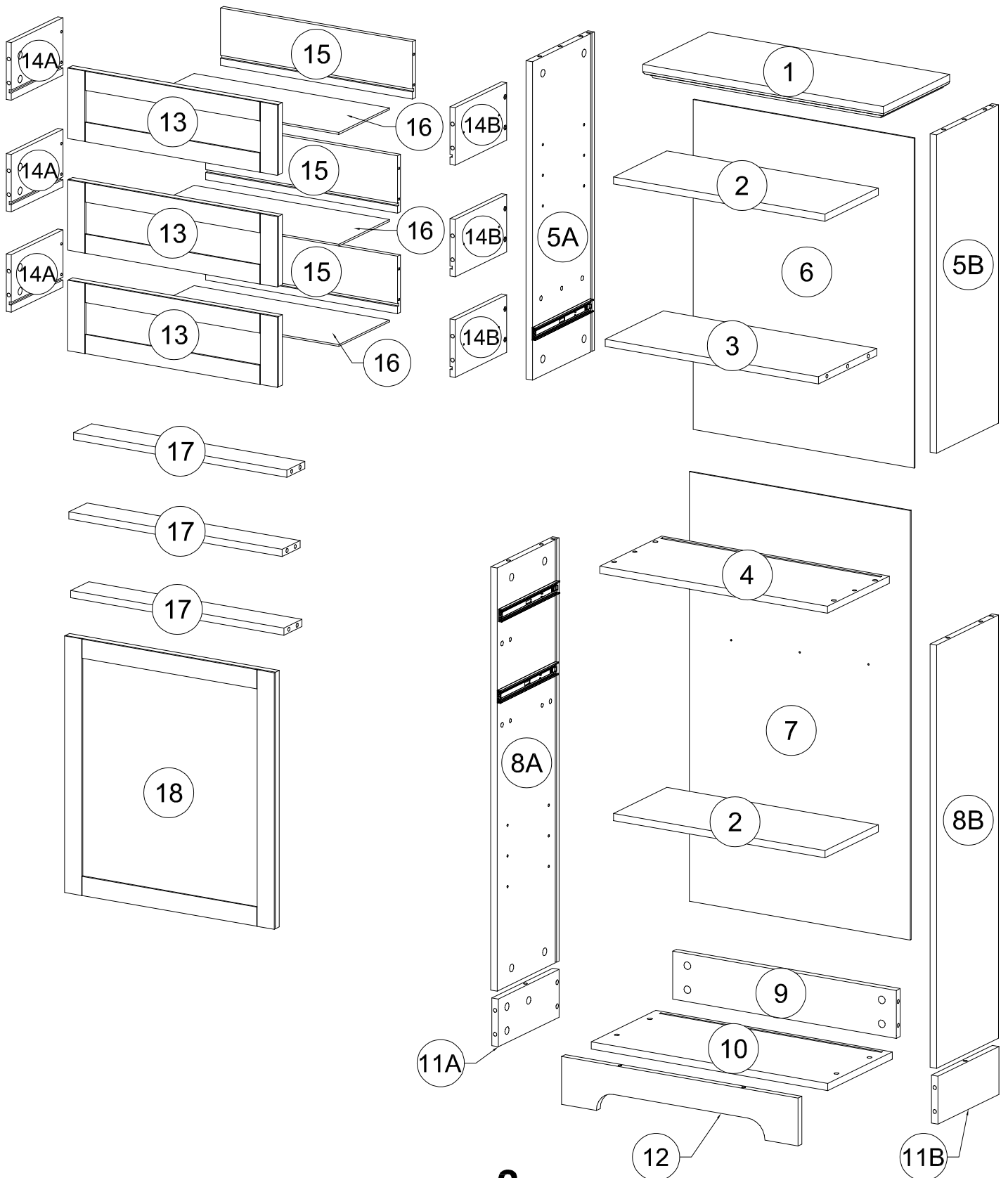

# ASSEMBLY INSTRUCTION



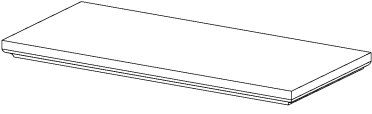
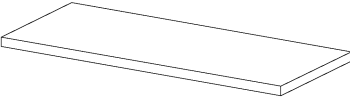
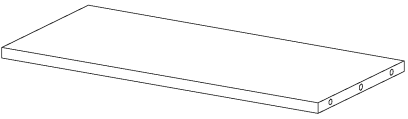
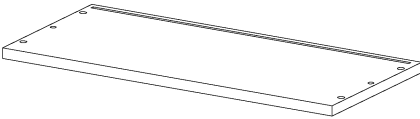
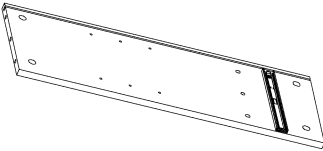
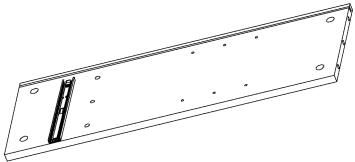
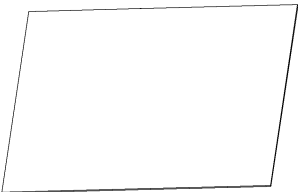
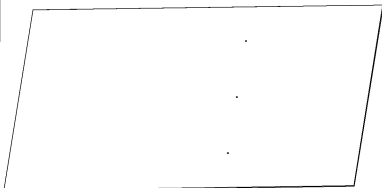
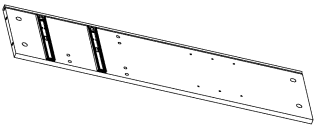
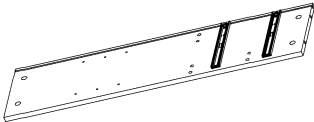
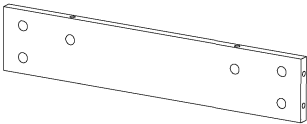
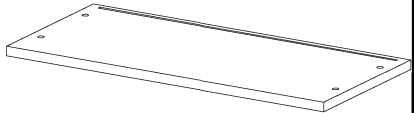
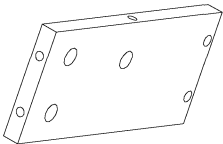
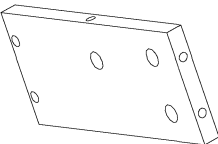
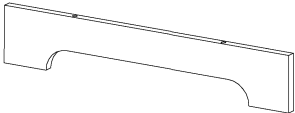
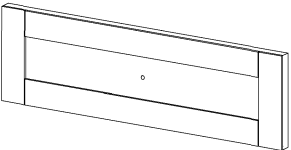
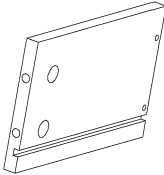
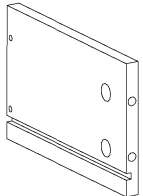



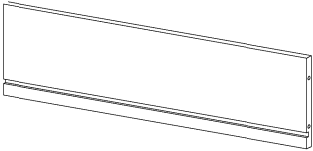

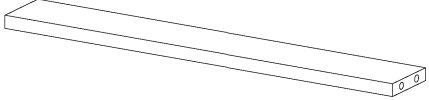
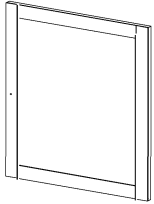

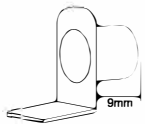
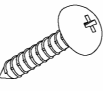
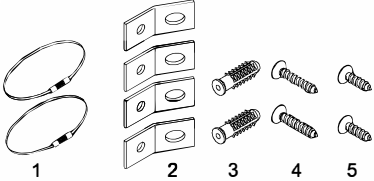

# Part List

<p><b>1</b></p>  <p>The top of the cabinet-1pc</p>	<p><b>2</b></p>  <p>MOVING SHELVES-2pcs</p>	<p><b>3</b></p>  <p>FIXED SHELF-1pc</p>
<p><b>4</b></p>  <p>CABINET DIVIDING PLATE-1pc</p>	<p><b>5A</b></p>  <p>HIP EDGE ON CABINET-1pc</p>	<p><b>5B</b></p>  <p>HIP EDGE ON CABINET-1pc</p>
<p><b>6</b></p>  <p>Cabinet Back-1pc</p>	<p><b>7</b></p>  <p>Cabinet Back-1pc</p>	<p><b>8A</b></p>  <p>HIP EDGE UNDER THE CABINET-1pc</p>
<p><b>8B</b></p>  <p>HIP EDGE UNDER THE CABINET-1pc</p>	<p><b>9</b></p>  <p>Short bar - 1pc</p>	<p><b>10</b></p>  <p>CABINET BOTTOM-1pc</p>
<p><b>11A</b></p>  <p>Short bar - 1pc</p>	<p><b>11B</b></p>  <p>Short bar - 1pc</p>	<p><b>12</b></p>  <p>Short bar - 1pc</p>
<p><b>13</b></p>  <p>DRAWER-FRONT Panels-3pcs</p>	<p><b>14A</b></p>  <p>DRAWER-SIDE Panels-3pcs</p>	<p><b>14B</b></p>  <p>DRAWER-SIDE Panes-3pcs</p>

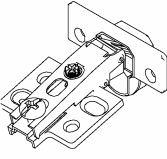
# Part List

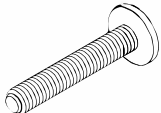
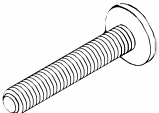
<p>15</p>  <p>DRAWER-Back Panels-3pcs</p>	<p>16</p>  <p>Panel- 3pcs</p>	<p>17</p>  <p>SUPPORT BAR- 3pcs</p>
<p>18</p>  <p>CABINET WINGS-1pc</p>		

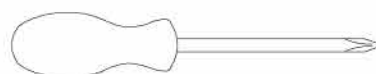

# Hardware List

<p><b>A</b></p>  <p>Link 1 - 50 pcs</p>	<p><b>B</b></p>  <p>Link 2- 12mm - 50 pcs</p>	<p><b>C</b></p>  <p>Ø8 x 30 mm Wood dowel 12pcs</p>
<p><b>D</b></p>  <p>Support Pin 8pcs</p>	<p><b>E</b></p>  <p>M4 x 20 mm Wood Screws 23pcs</p>	<p><b>F</b></p>  <p>Wall brackets 1set</p>
<p><b>G</b></p>  <p>#4 x 30 mm Wood Screws 12pcs</p>	<p><b>H</b></p>  <p>Hinge - 2pcs</p>	<p><b>R</b></p>  <p>CABINET DOOR HANDLES - 4pcs</p>
<p><b>J</b></p>  <p>M4 x 20mm Hex-Head bolts 3pcs</p>	<p><b>K</b></p>  <p>M4 x 25mm Hex-Head bolts 1pc</p>	<p><b>L</b></p>  <p>#4 x 15 mm Wood Screws 16pcs</p>
<p><b>N</b></p>  <p>Plastic button 50pcs</p>	<p><b>M</b></p>  <p>Iron Steel 2pcs</p>	



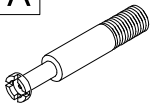

**Assembly Tools Required (Not Included)**

# STEP 1.1: Following below illustration:

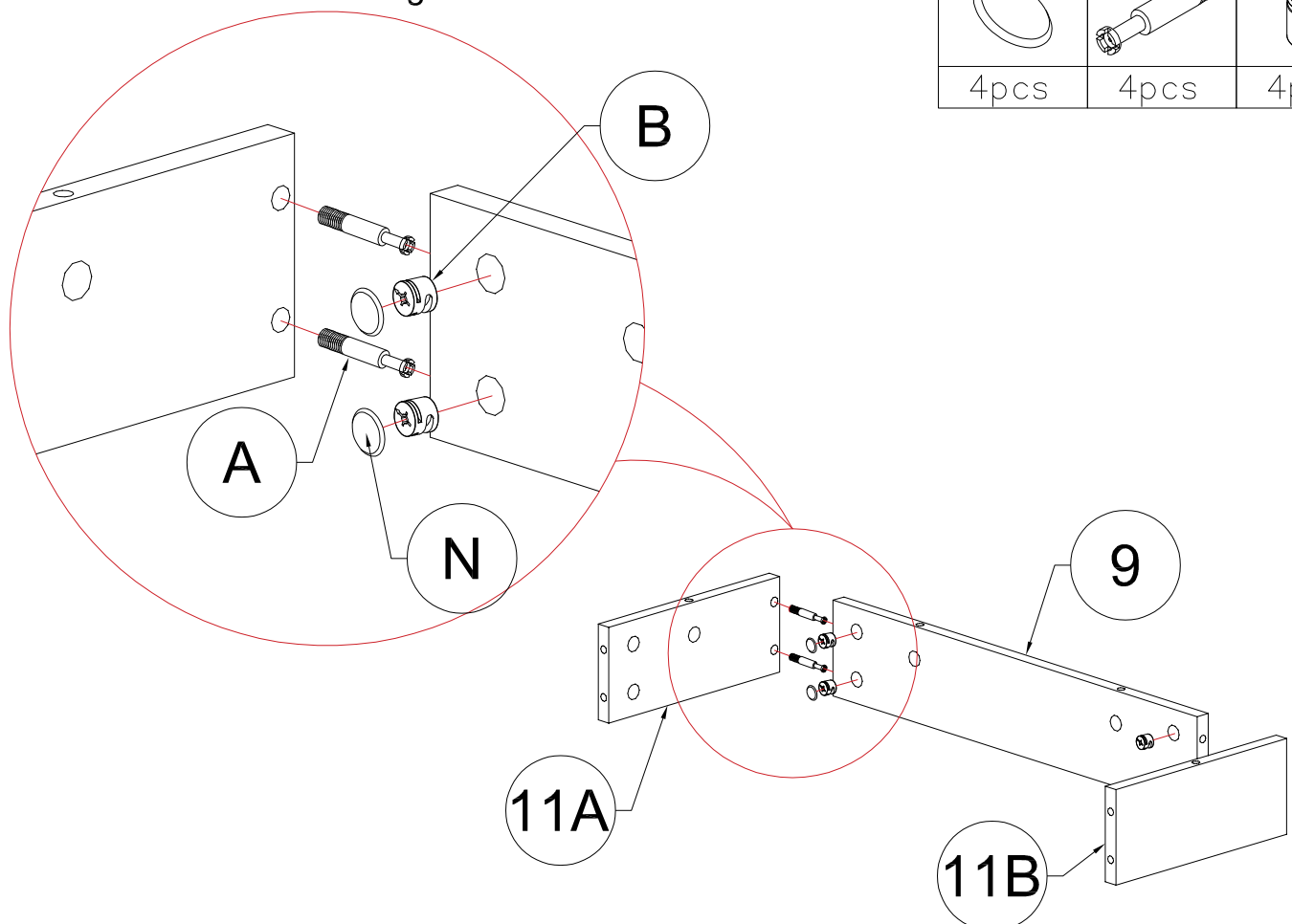
N	A	B
		
4pcs	4pcs	4pcs



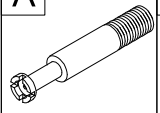

# STEP 1.2: Following below illustration:

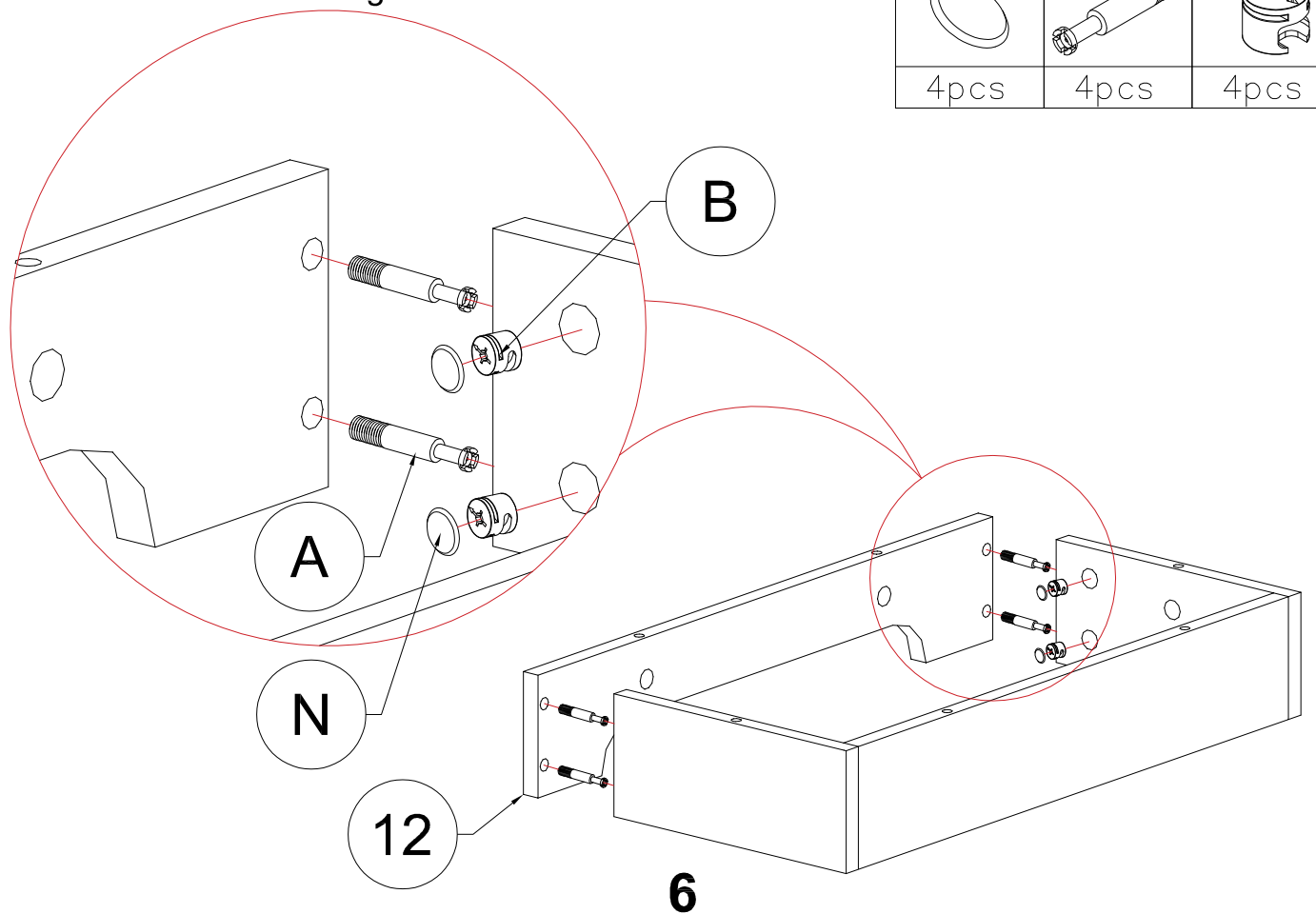
N	A	B
		
4pcs	4pcs	4pcs



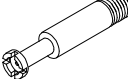

# STEP 2: Following below illustration:

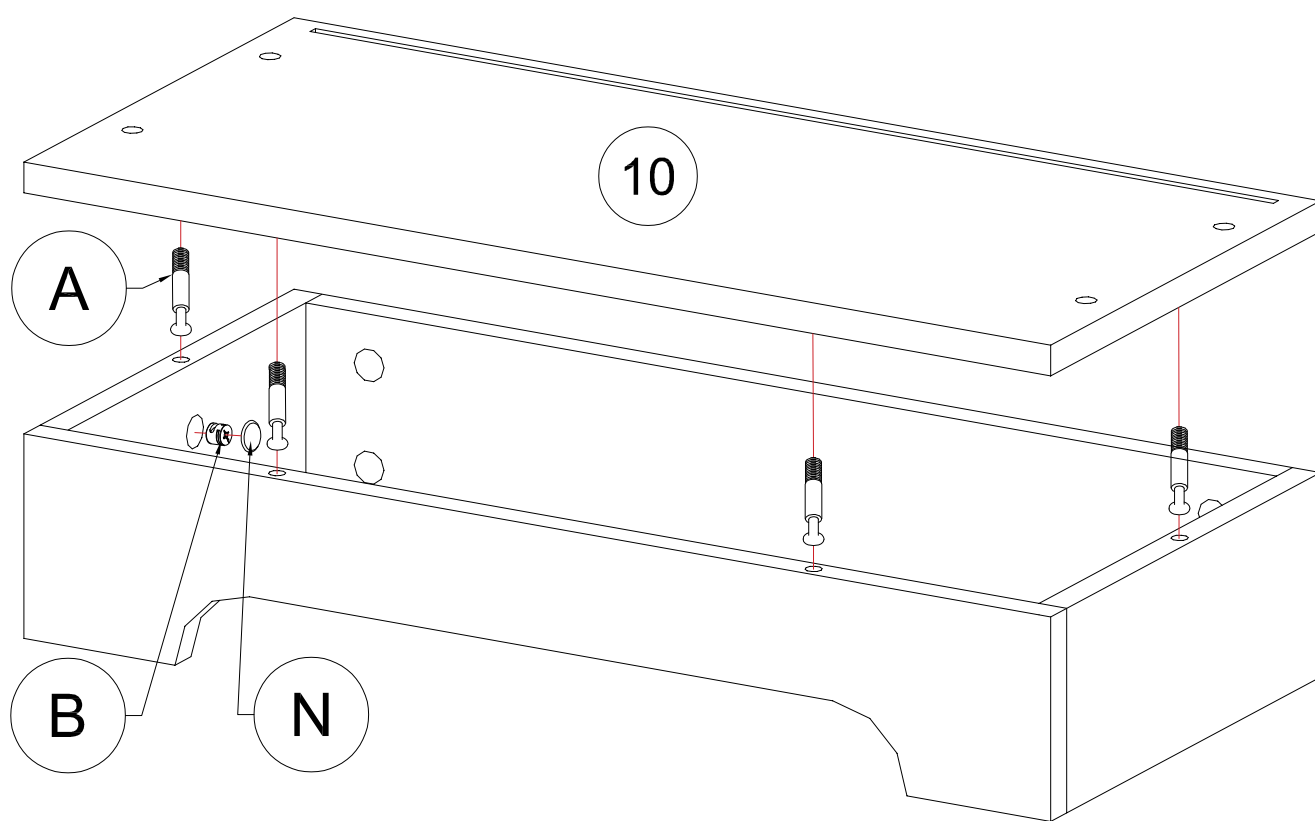
N	A	B
		
4pcs	4pcs	4pcs





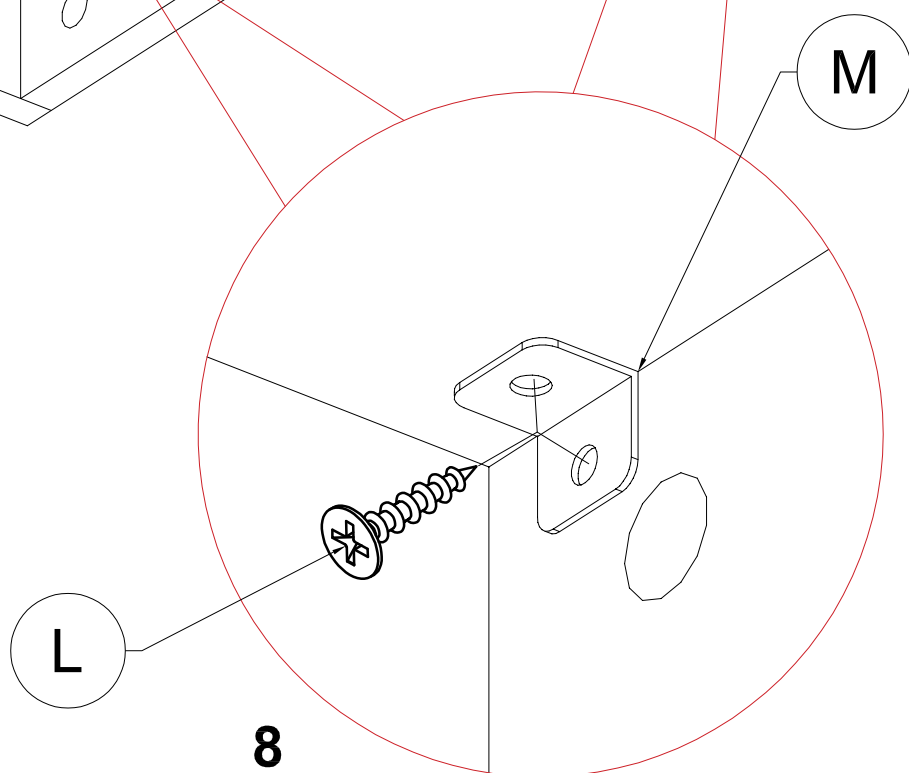
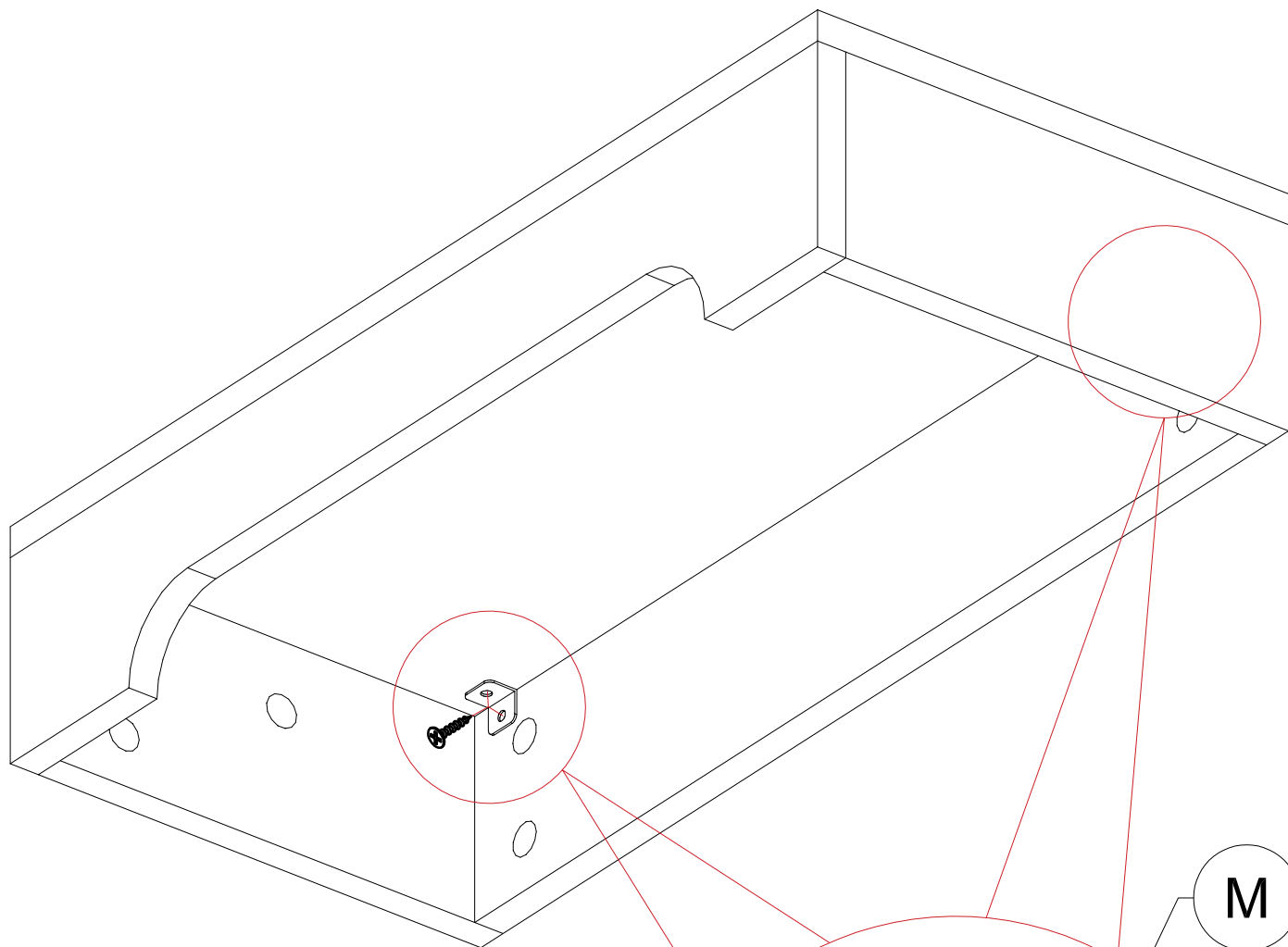

# STEP 3: Following below illustration:

M		L	
	2pcs		4pcs

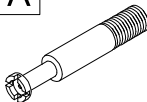

# STEP 4: Following below illustration:

<b>N</b> 	<b>C</b> 	<b>A</b> 	<b>B</b> 
6pcs	6pcs	6pcs	6pcs

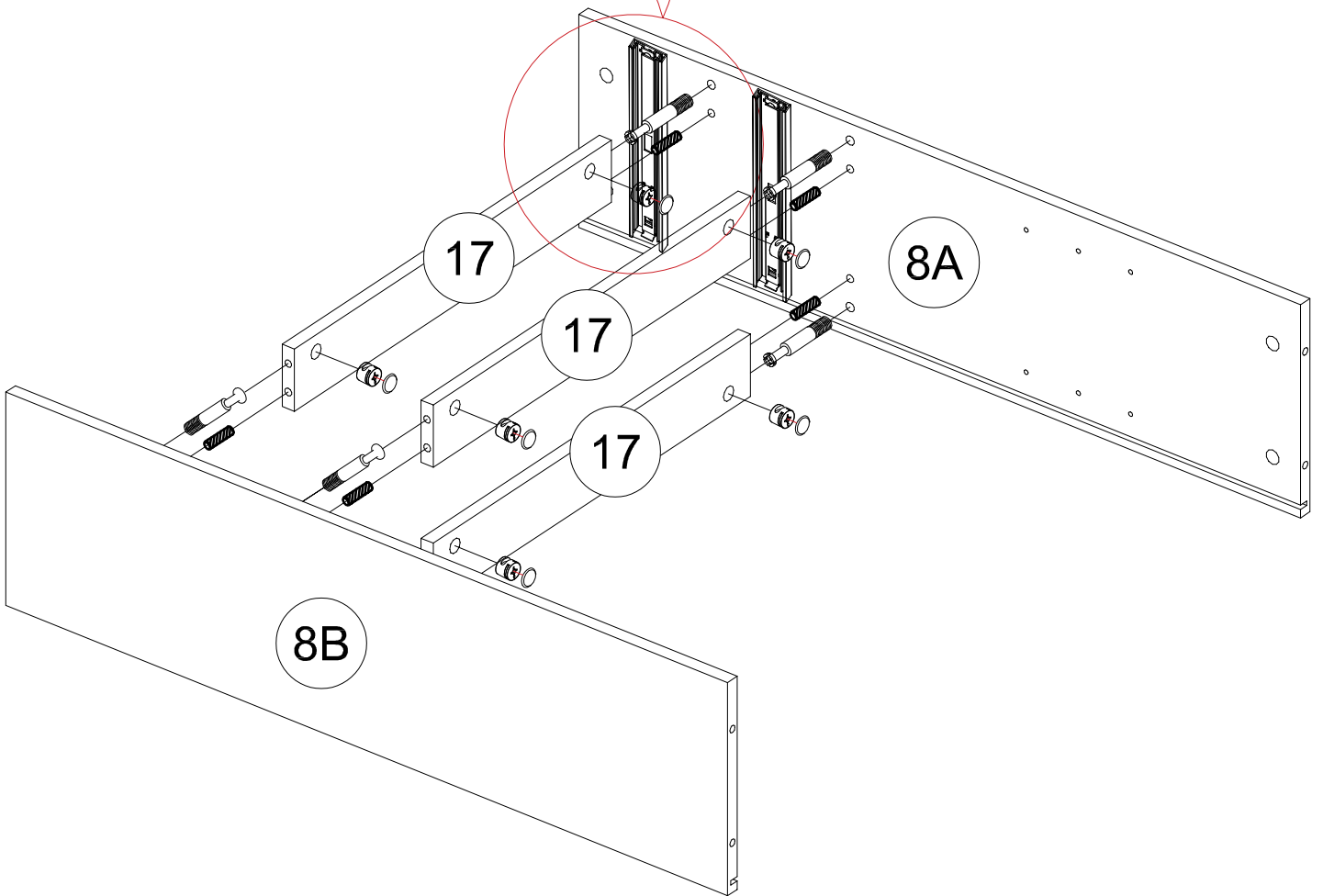
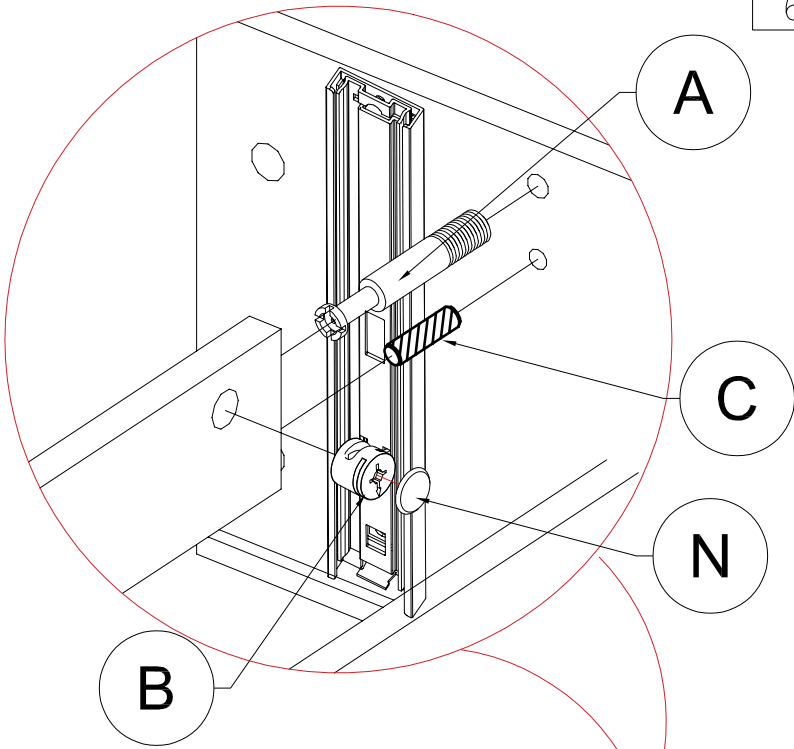

# STEP 5: Following below illustration:

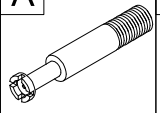
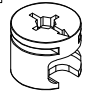

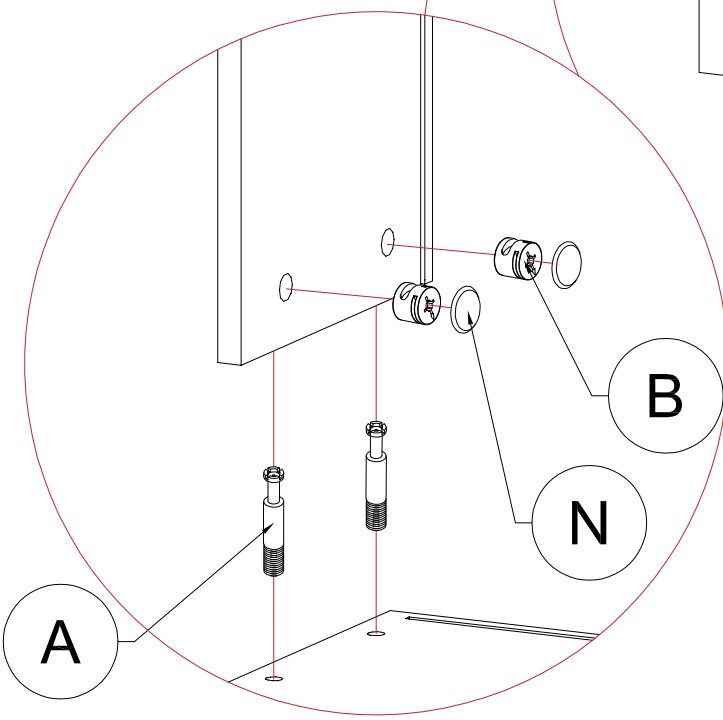
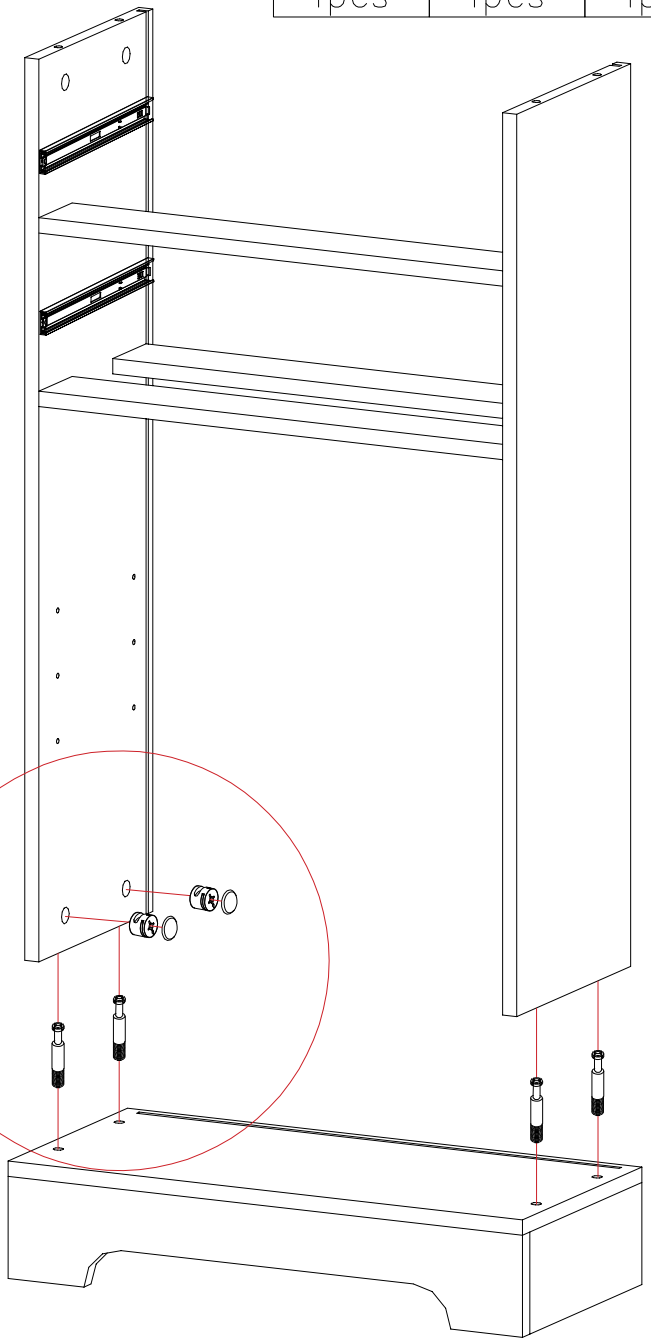
<b>N</b>	<b>A</b>	<b>B</b>
		
4pcs	4pcs	4pcs

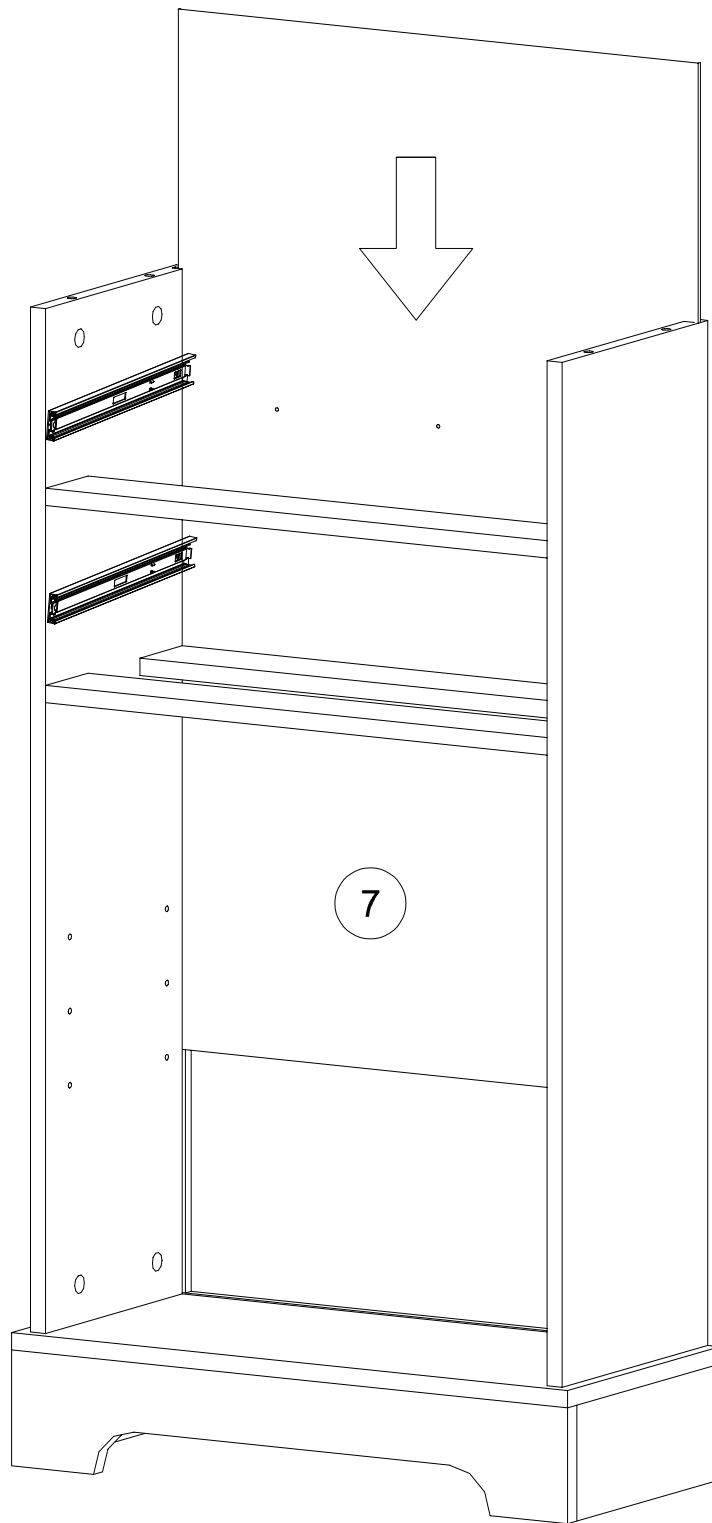

**STEP 6:** Following below illustration:



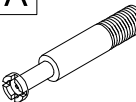

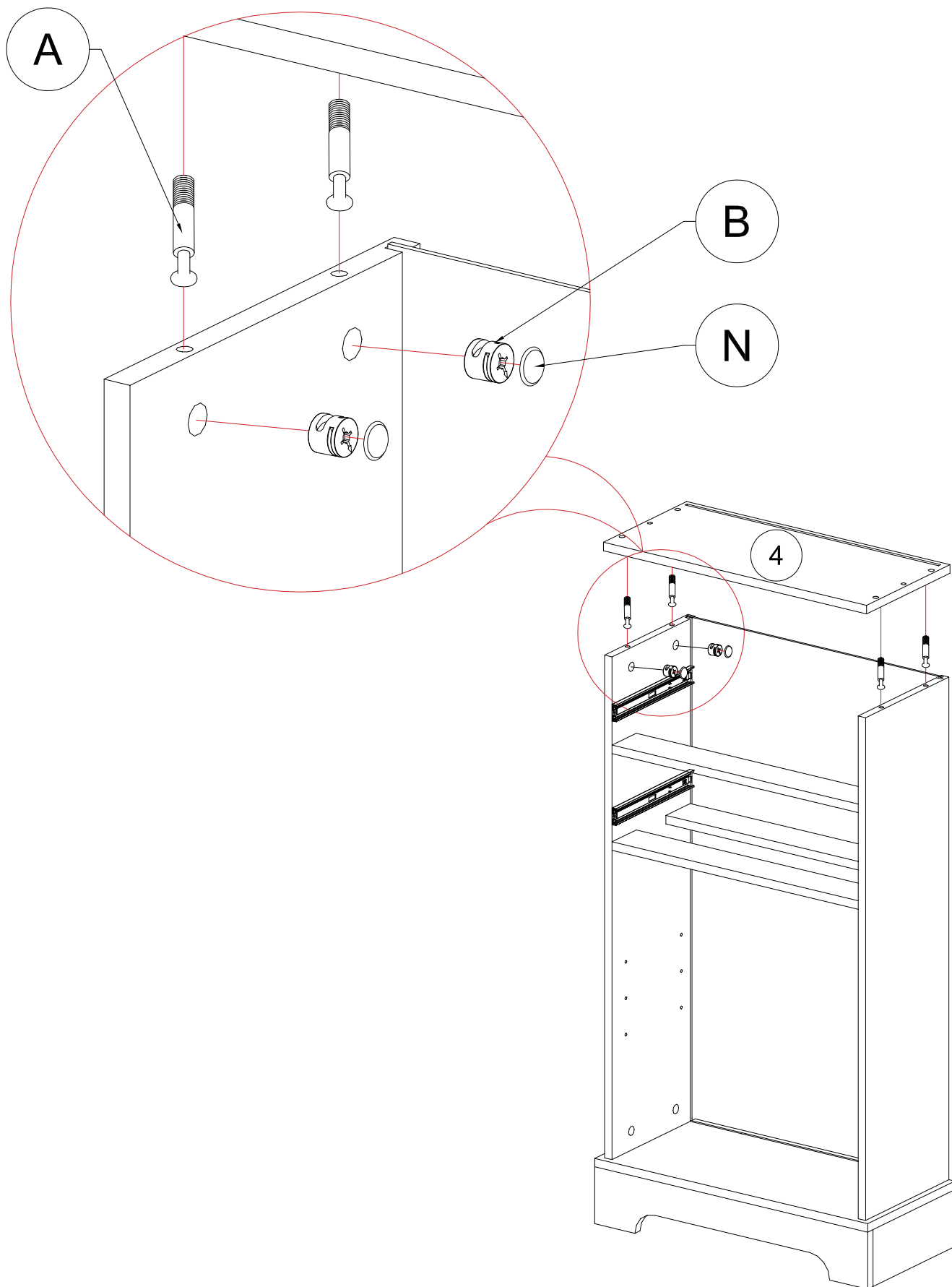

# STEP 7: Following below illustration:

<b>N</b> 	<b>A</b> 	<b>B</b> 
4pcs	4pcs	4pcs



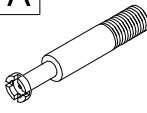

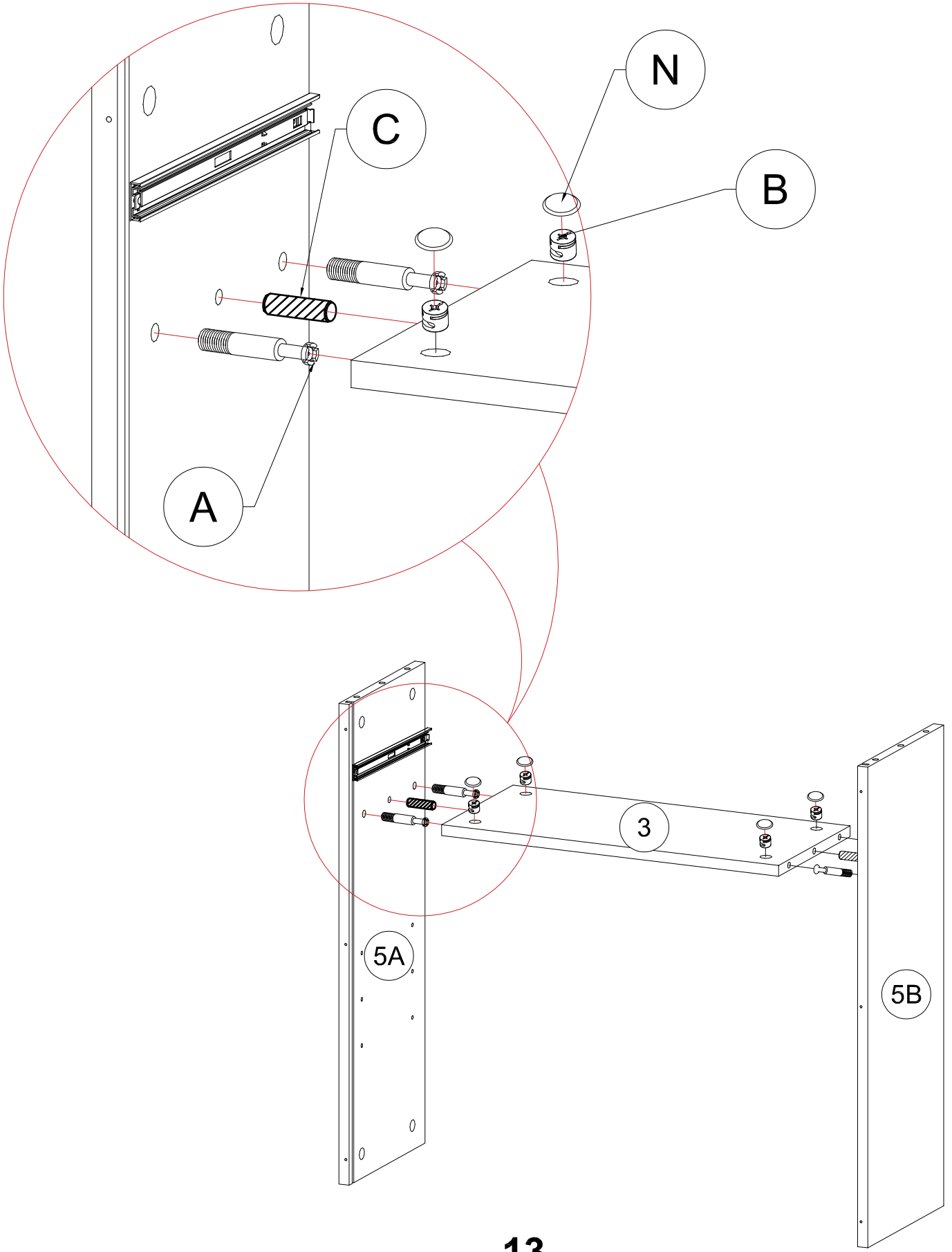

# STEP 8: Following below illustration:

N	C	A	B
			
4pcs	2pcs	4pcs	4pcs

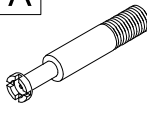

# STEP 9: Following below illustration:



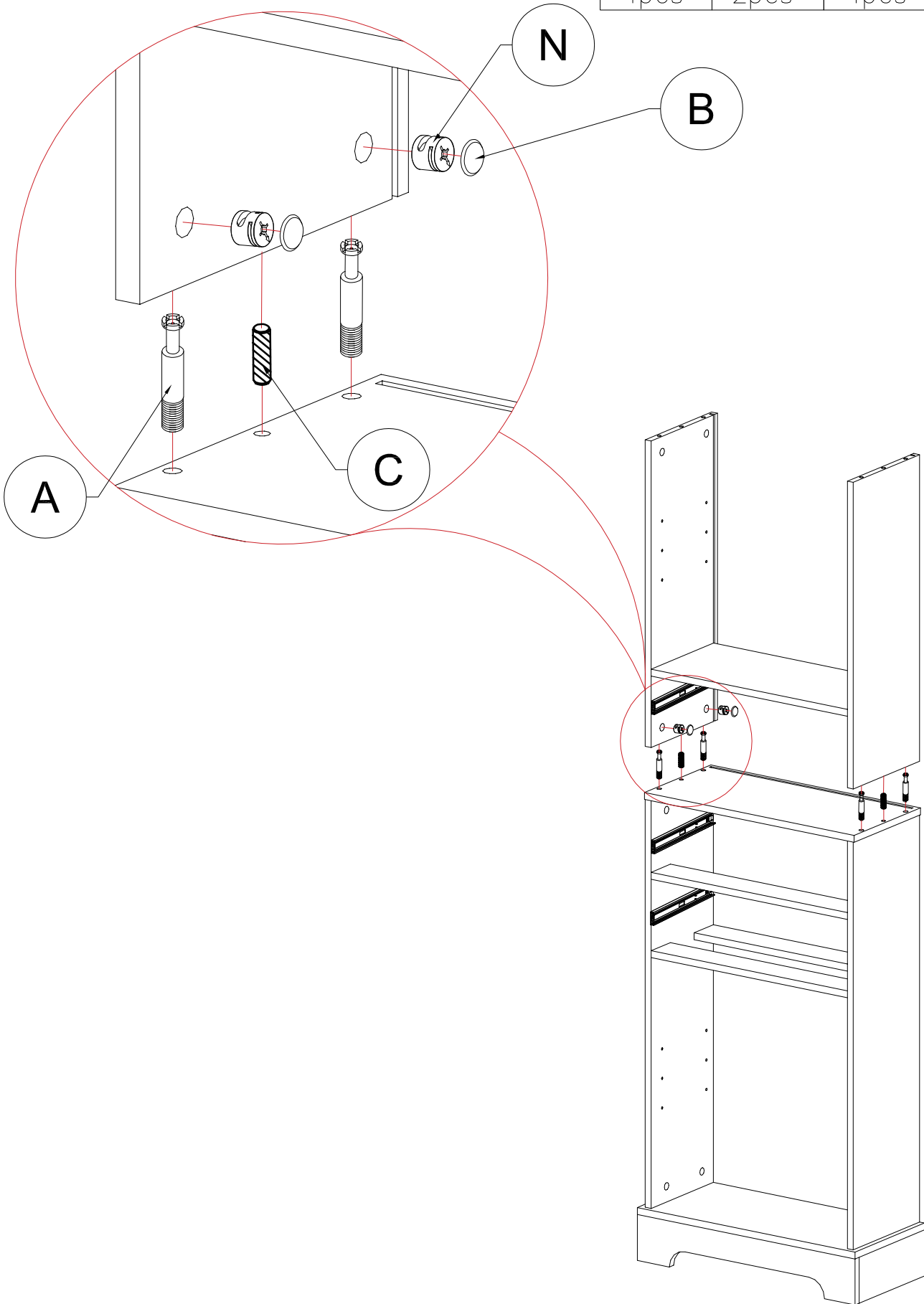

<b>N</b> 	<b>C</b> 	<b>A</b> 	<b>B</b> 
4pcs	2pcs	4pcs	4pcs



**STEP 10:** Following below illustration:



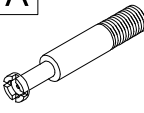

# STEP 11: Following below illustration:

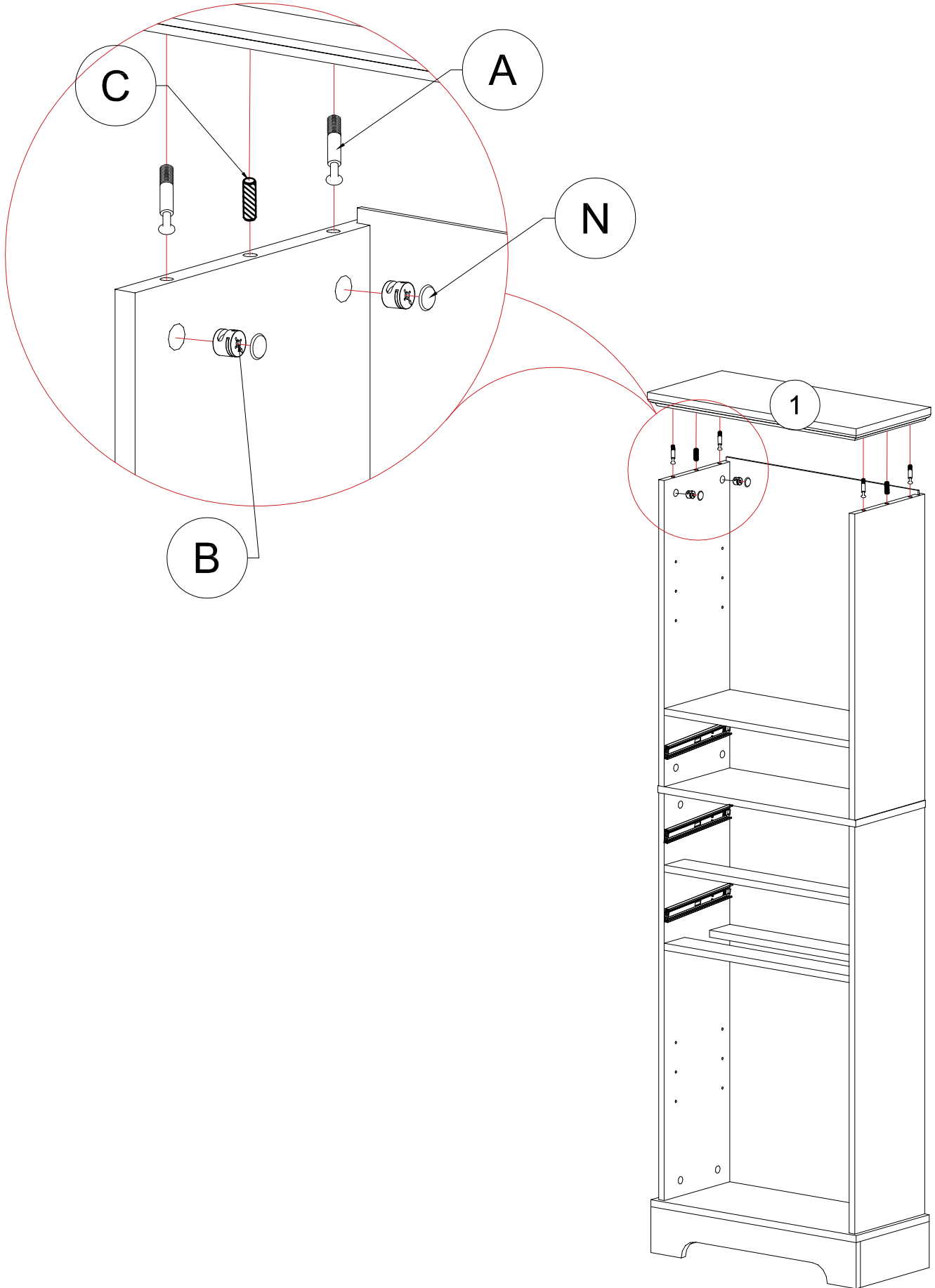
<b>N</b> 	<b>C</b> 	<b>A</b> 	<b>B</b> 
4pcs	2pcs	4pcs	4pcs

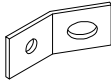

# STEP 12: Following below illustration:

F-2	F-5	E
		
2pcs	2pcs	23pcs

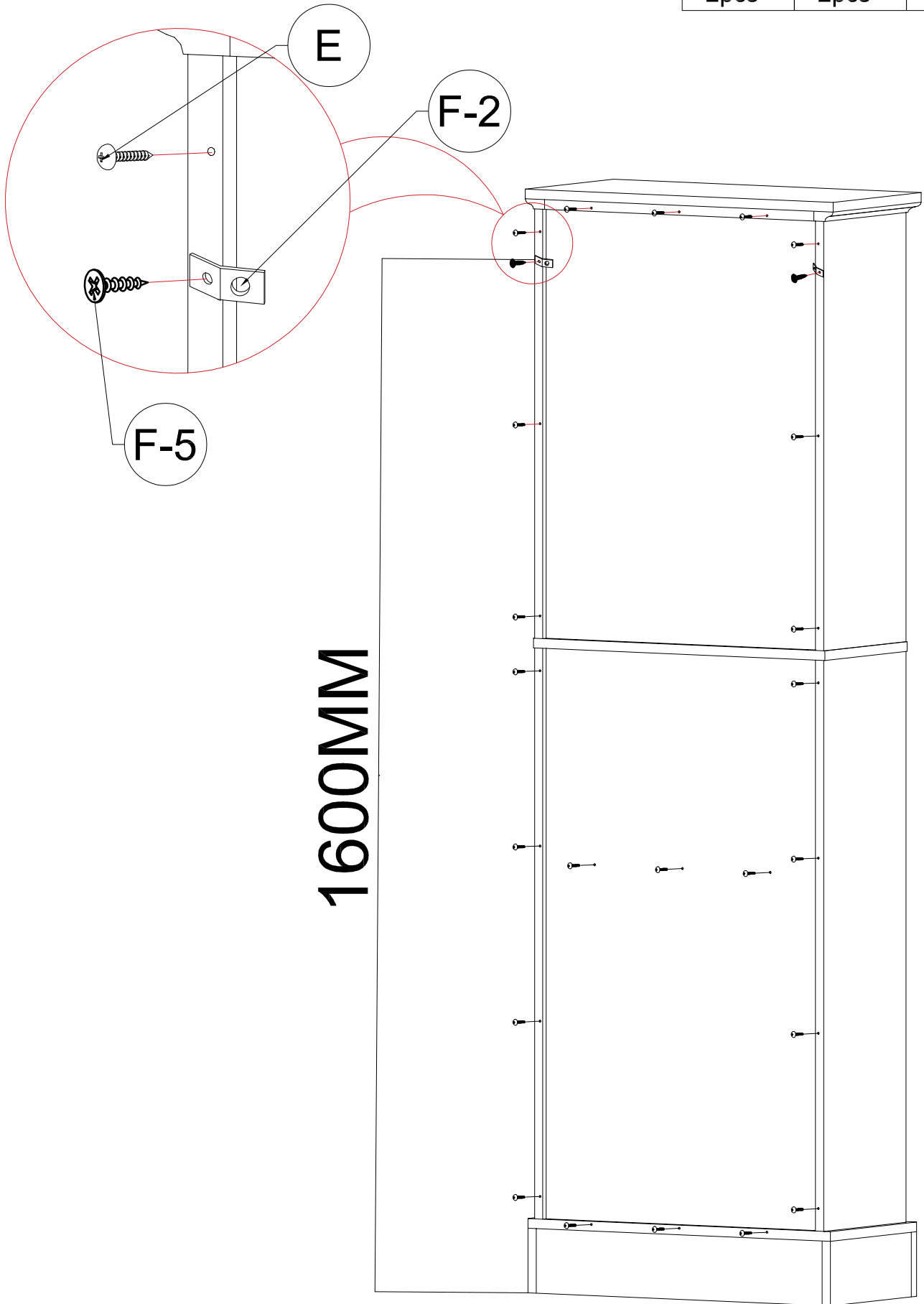

# STEP 13: Following below illustration:



D

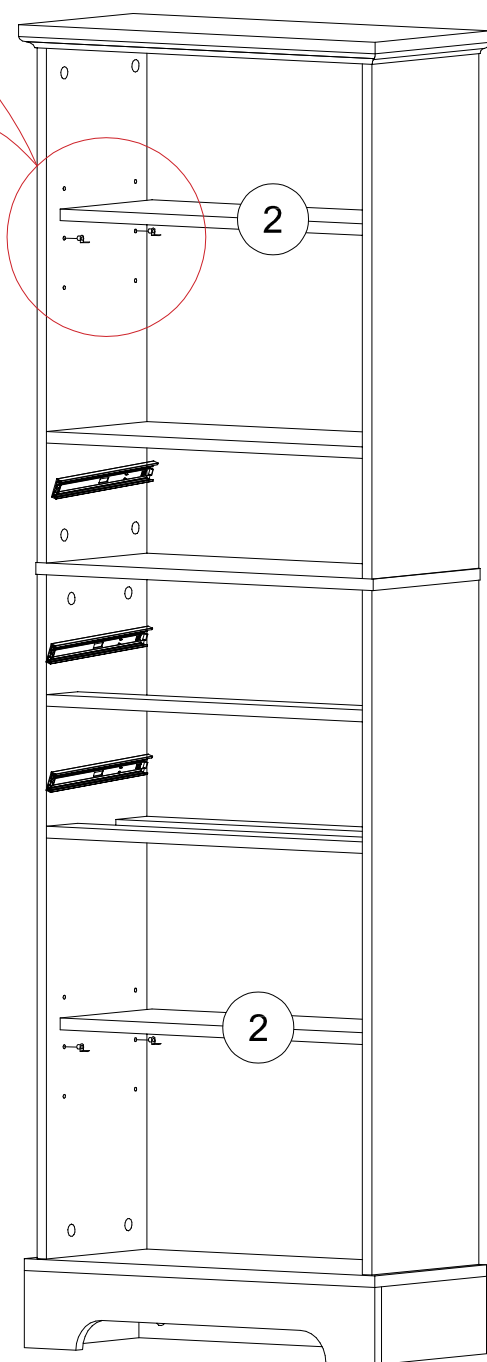
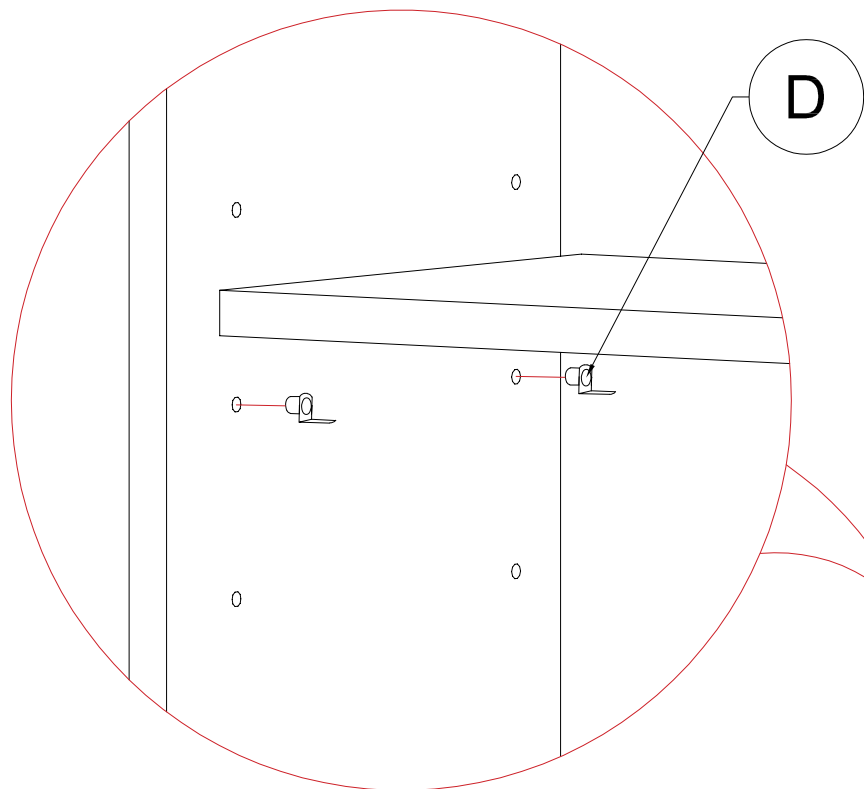

8pcs

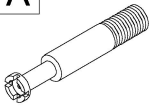

**STEP 14.1:** Following below illustration:

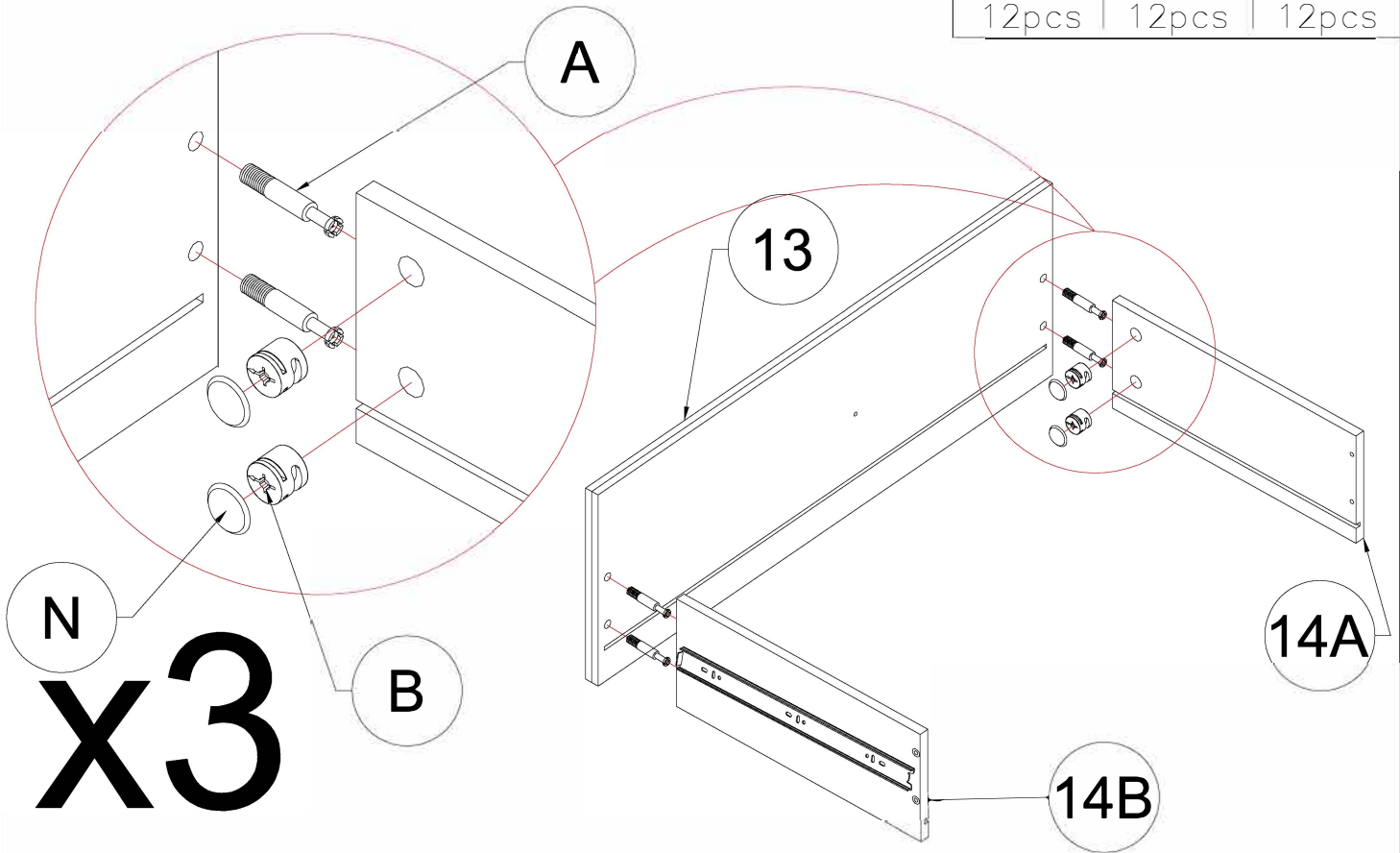

<b>N</b> 	<b>A</b> 	<b>B</b> 
12pcs	12pcs	12pcs

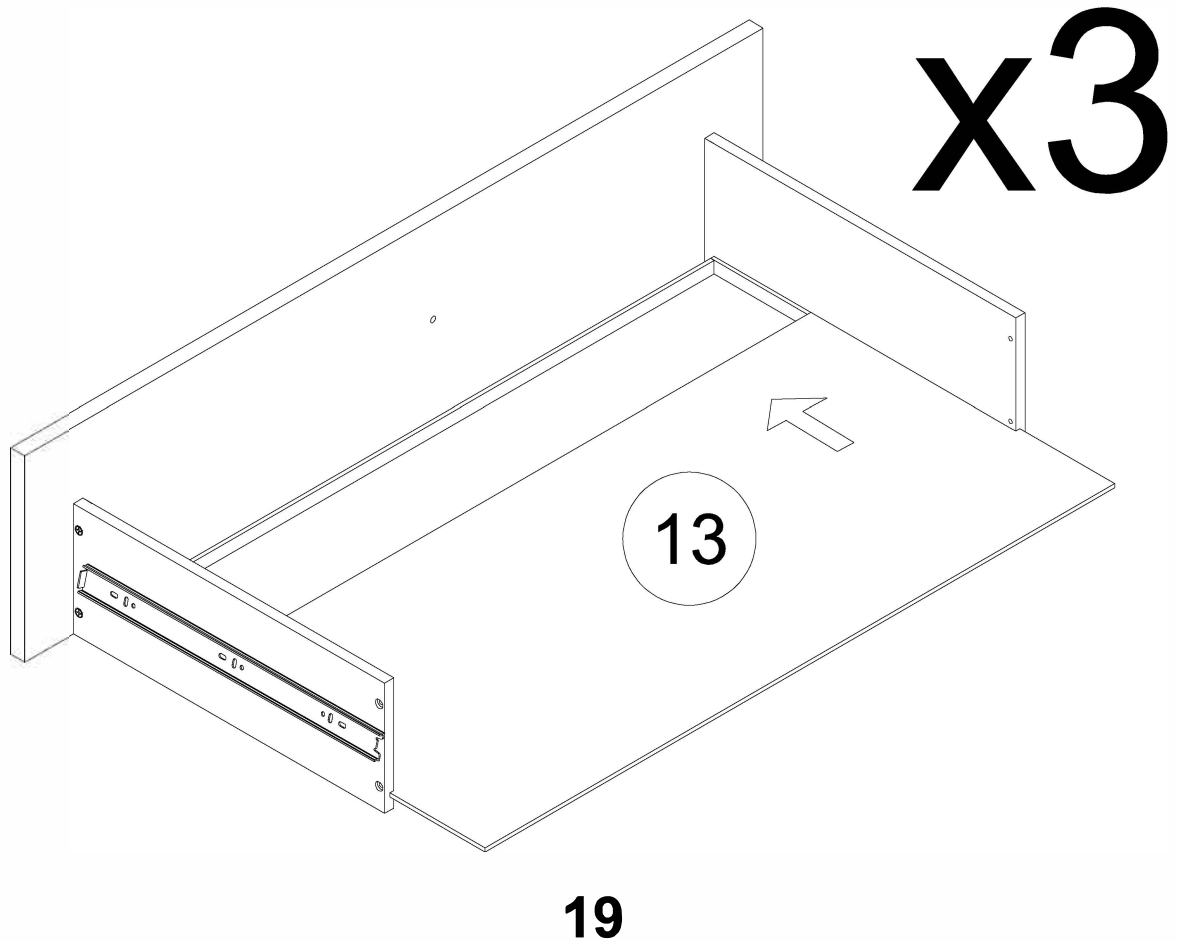

**STEP 14.2:** Following below illustration:

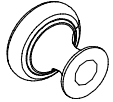
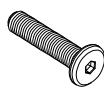

# STEP 15: Following below illustration:

<b>R</b> 	<b>J</b> 	<b>G</b> 
3pcs	3pcs	12pcs

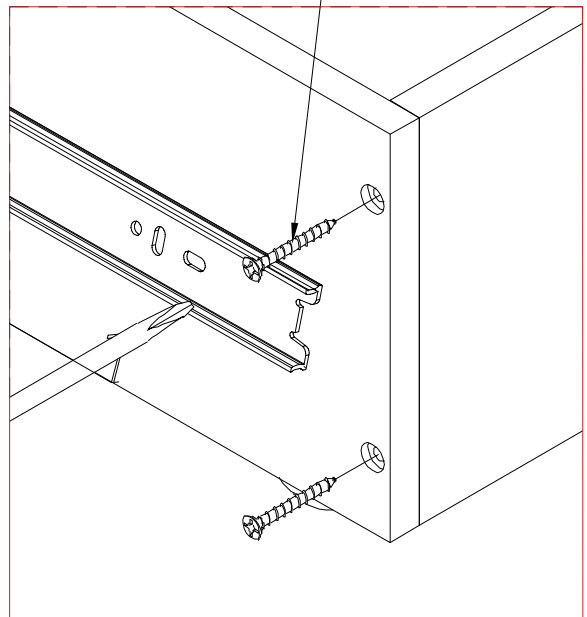
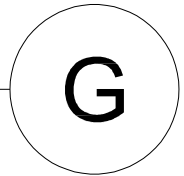
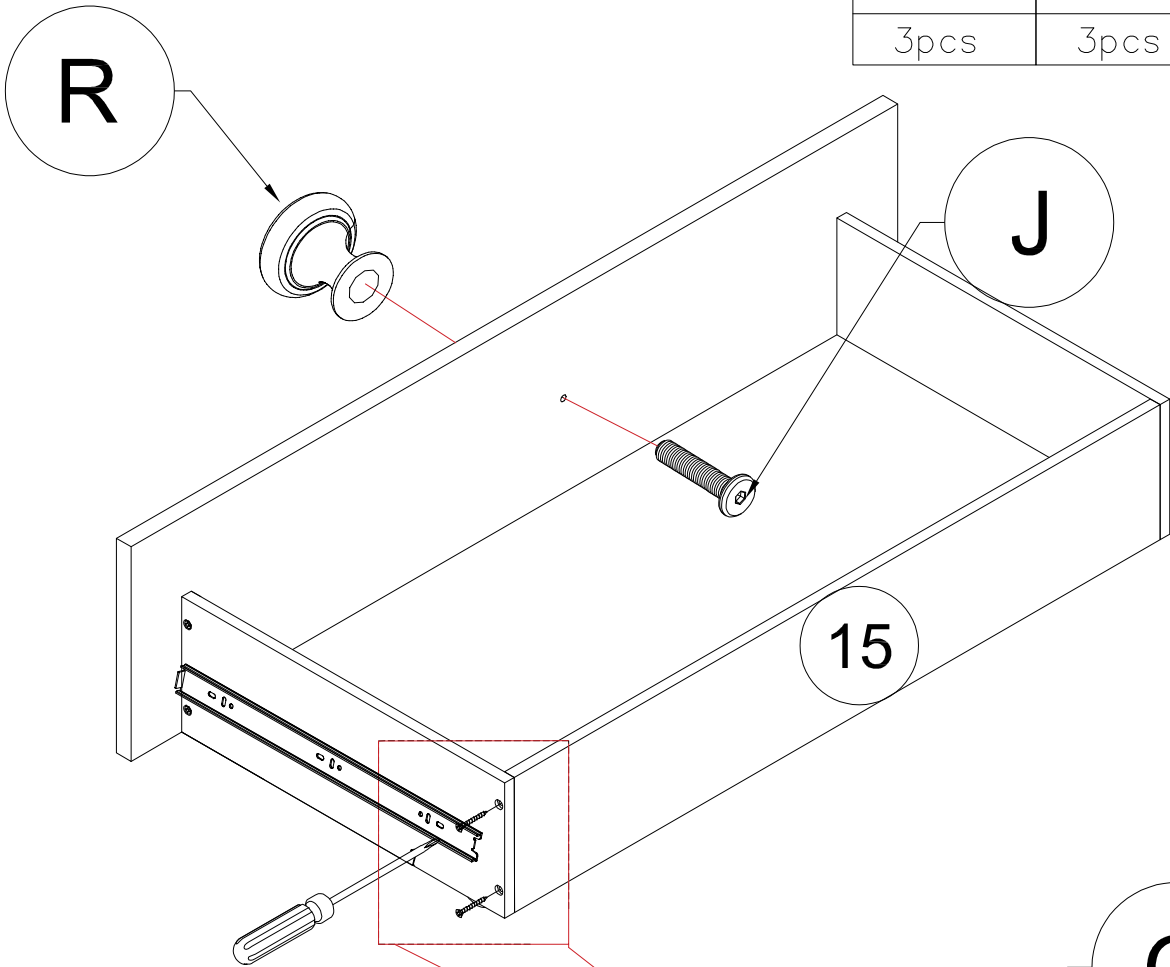

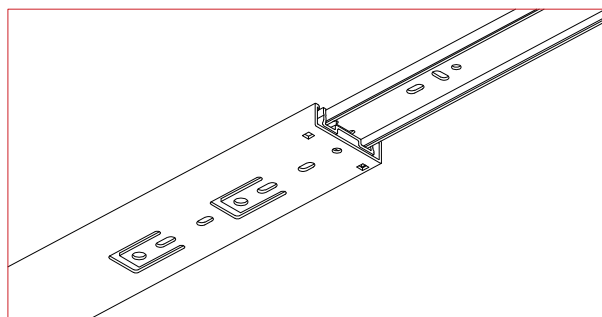
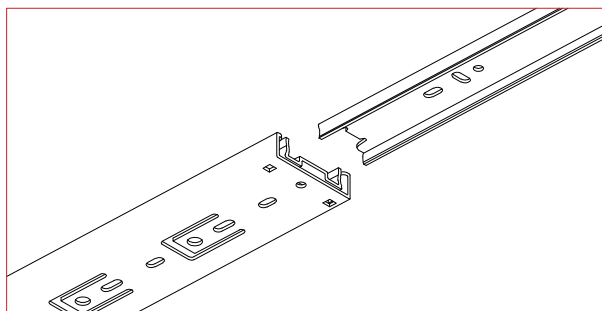
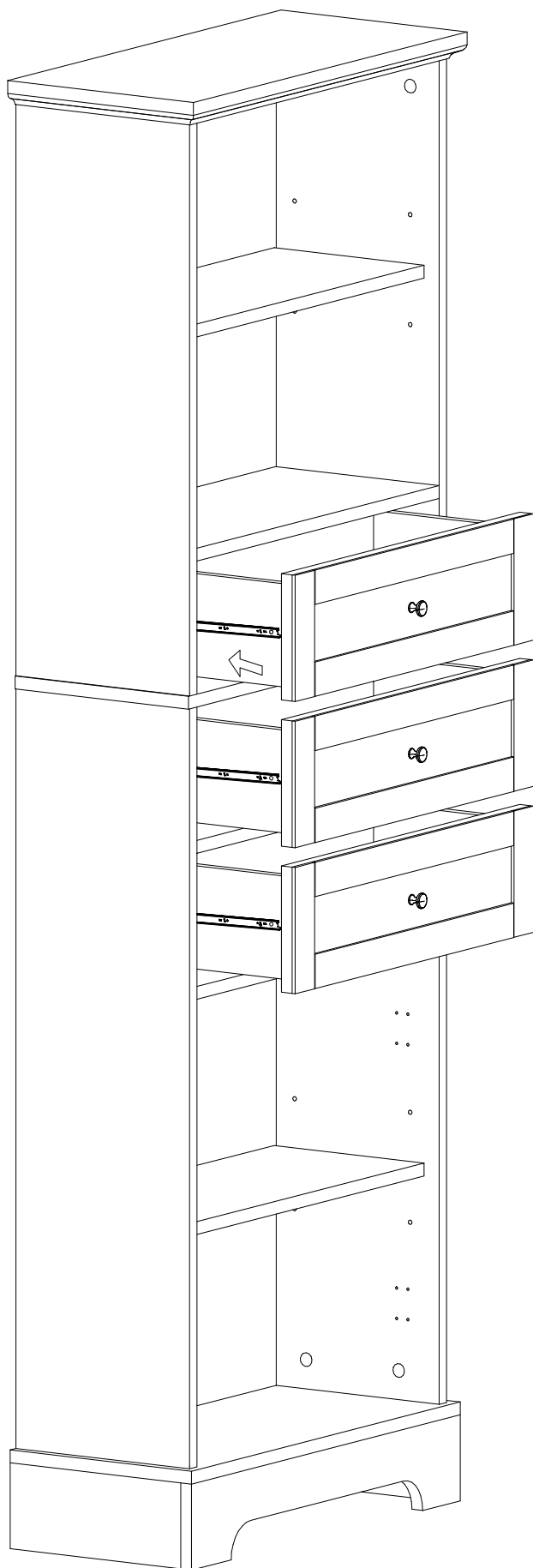

**x3**

# STEP 16: Following below illustration:



# STEP 17: Following below illustration:

H 	L 
2pcs	4pcs

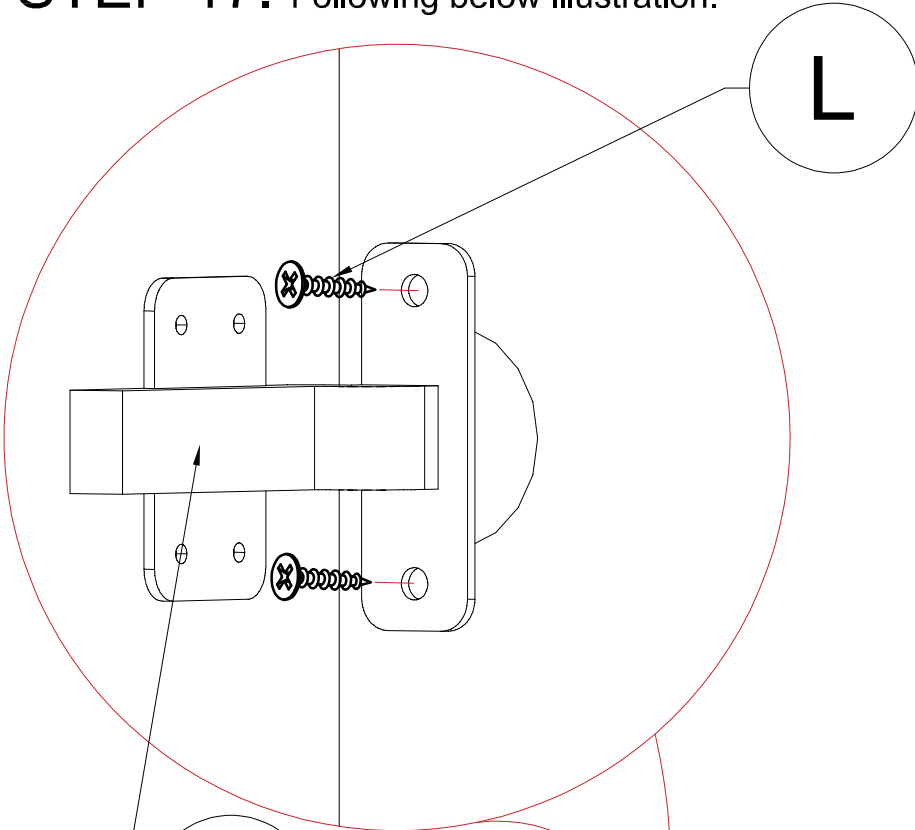

H

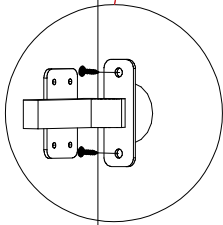

L

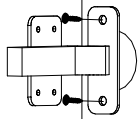

18



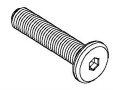

# STEP 18: Following below illustration:

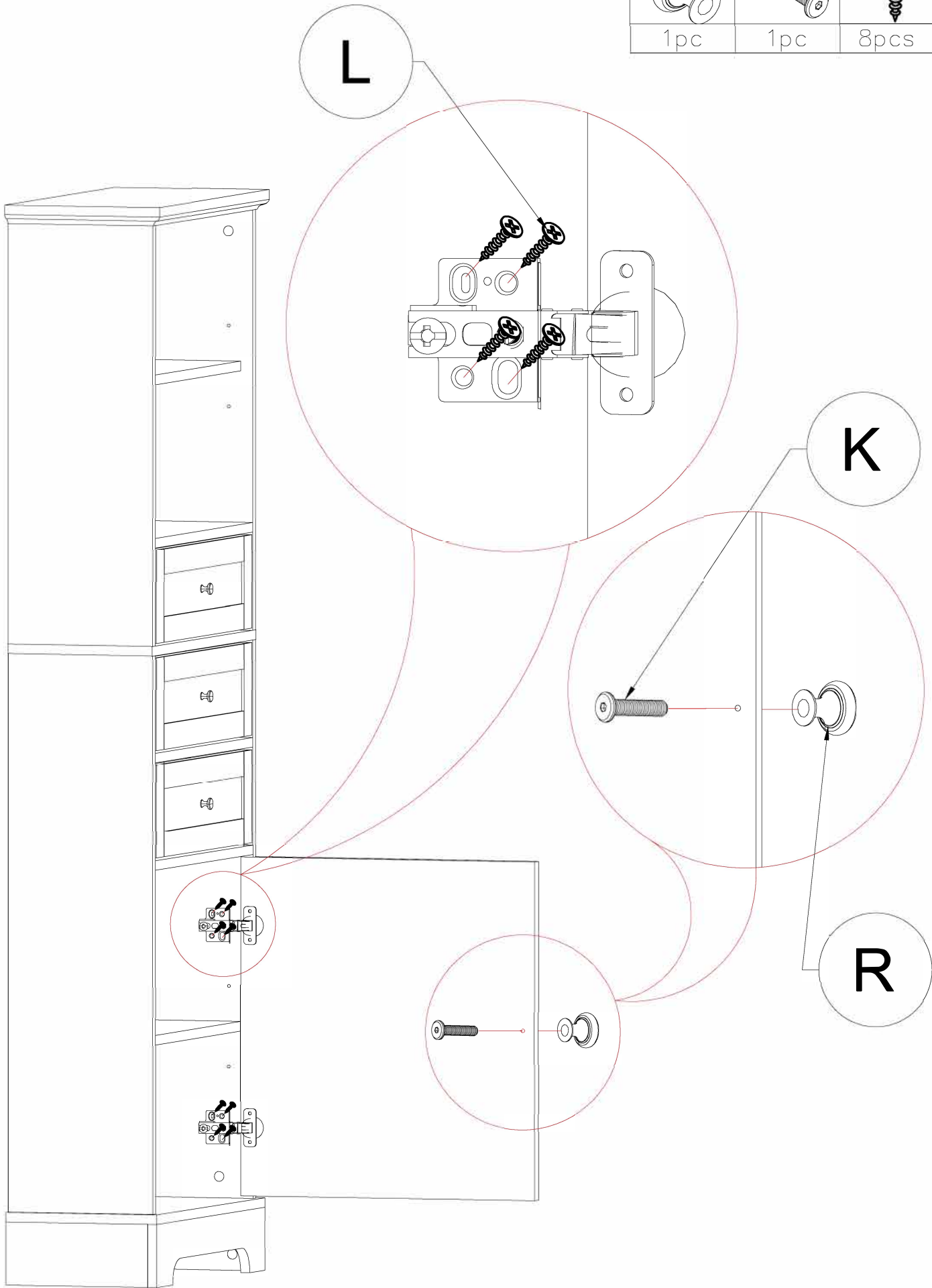
R	K	L
		
1pc	1pc	8pcs

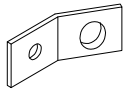

# STEP 19: Following below illustration:

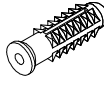
F-2	F-4	F-3
		
2pcs	2pcs	2pcs

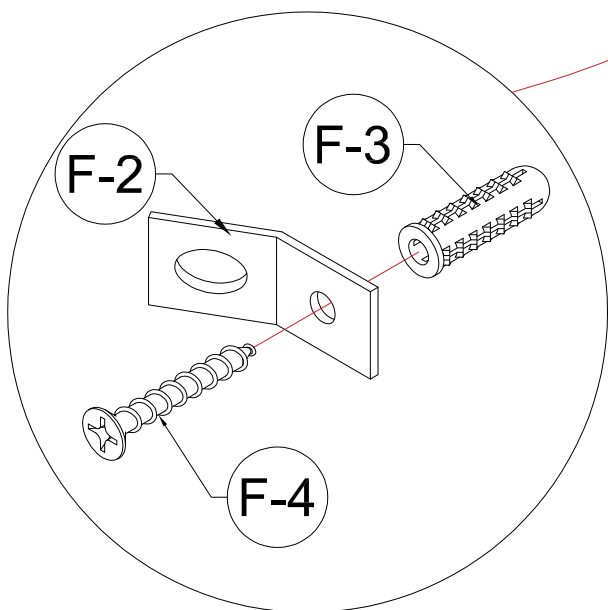
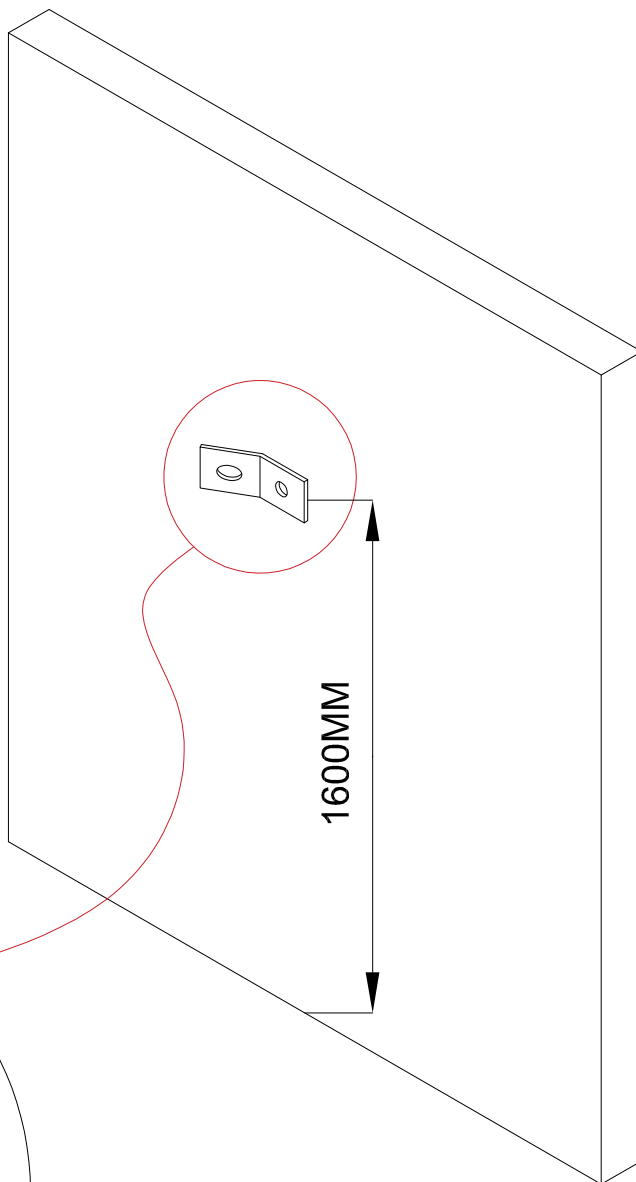

**STEP 20:** Following below illustration:

F-1



2pcs

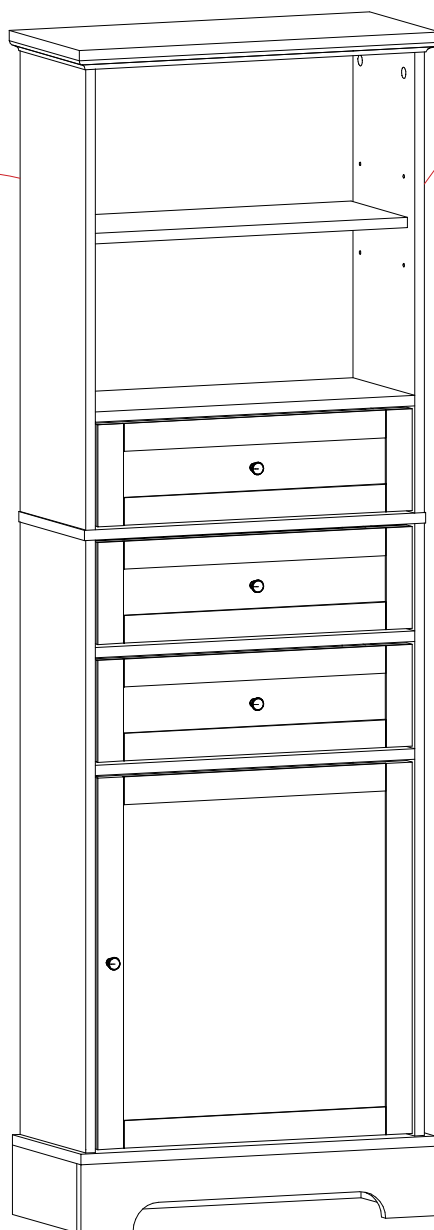
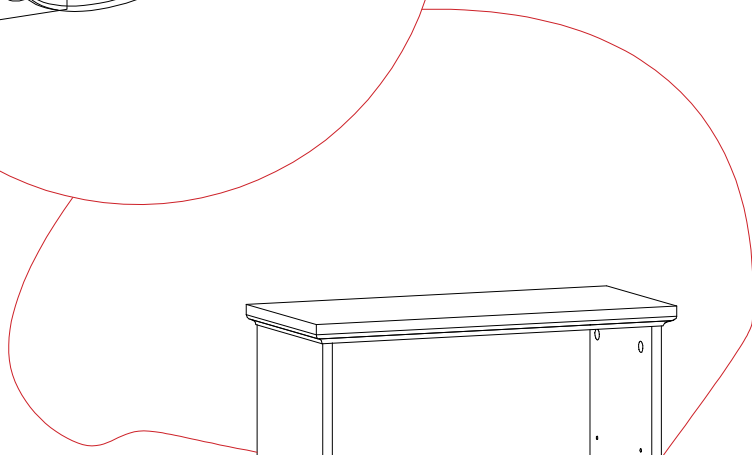
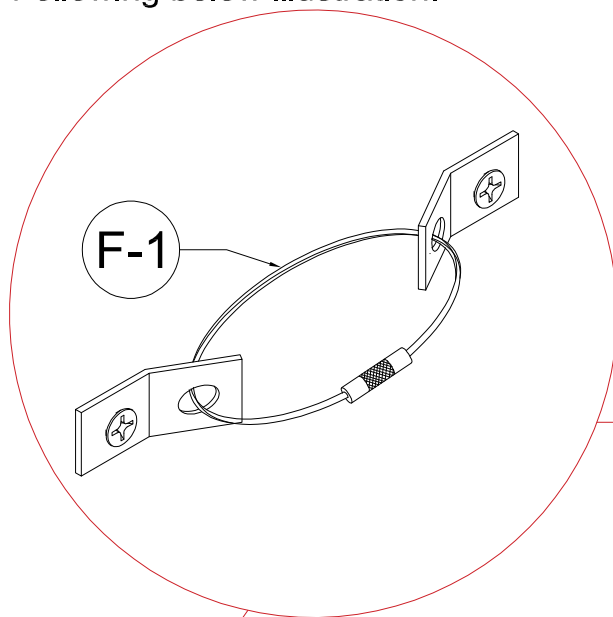

# FINISH

