

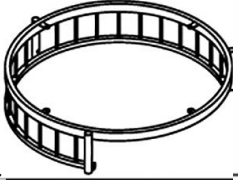

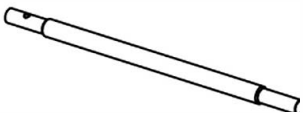

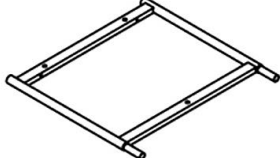

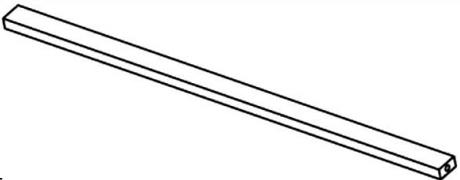



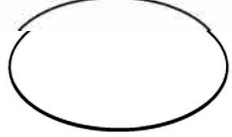
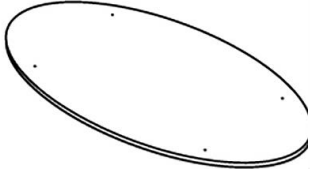

# ASSEMBLY INSTRUCTION

Thank you for purchasing the quality product. Be sure to check all packing material carefully for small parts which may have come loose inside the cation during shipment. Seperate, identify and count all parts and metal hardware. Compare with all parts list to be sure all parts are present. If any part(s) are missing or damaged, please contact your local furniture dealer. For efficient and speedy service, please indicate the model number and code letter of part(s) needed.

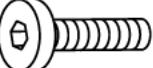
\*\*\* Do not fully tighten screws until fully assembled \*\*\*

COMPONENT PARTS		
DESCRIPTION	PART NAME	QTY(PCS)
①	TOP FRAME 	1
②	LEG 	3
③	H-FRAME 	2
④	CROSS TUBE 	3
⑤	SOCK TUBE 	7
⑥	ROUND BOARD 	1
⑦	OVAL BOARD 	1
⑧	GLASS 	1

# HARDWARE REQUIRED

Ⓐ		ALLEN KEY		1 PC
Ⓑ		BOLT	ϕ1/4"*12mm	3 PCS
Ⓒ		BOLT	ϕ1/4"*32mm	6 PCS
Ⓓ		SCREW	8#*38mm	4 PCS
Ⓔ		SCREW	ϕ4mm*10mm	4 PCS
Ⓕ		PLUG	13mmSQ	2 PCS
Ⓖ		CAP	ϕ3/4"	7 PCS
Ⓗ		CAP	ϕ25mm	7 PCS
Ⓘ		SUCKER		4 PCS

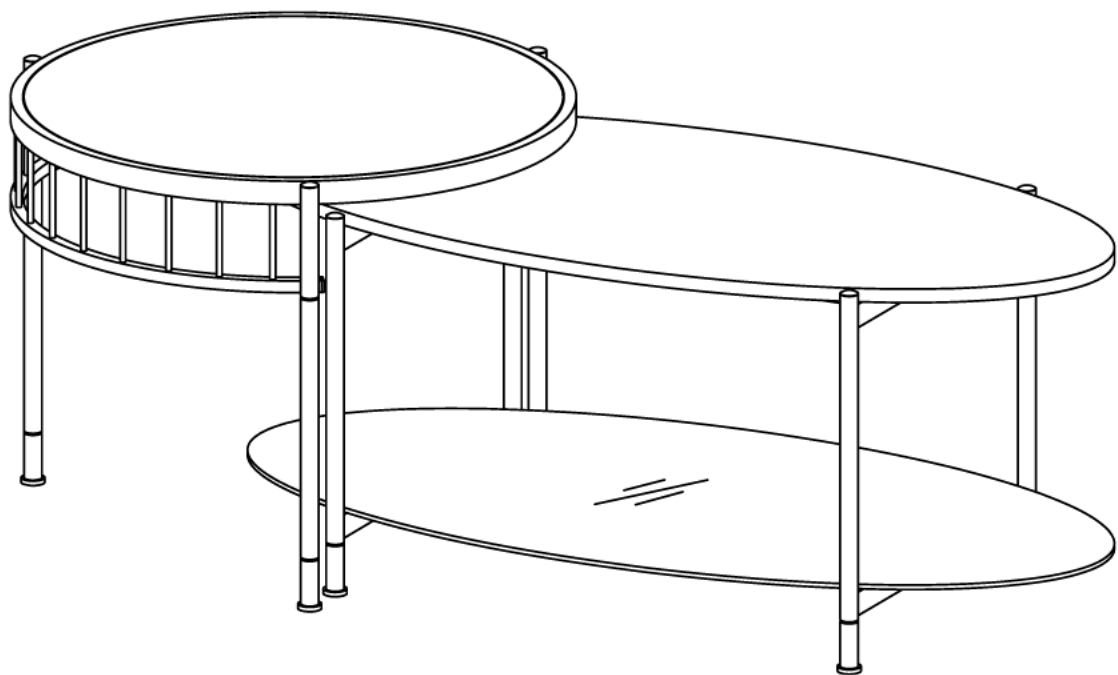

## Attention

\*\*\* Assembly required: 2-people recommended.



\*\*\* Some number parts listed on the instruction sheet may not be in parts bag as they may already be assembled. Carefully check parts and packing materials prior to ordering replacements.

# How to assemble:

## STEP 1

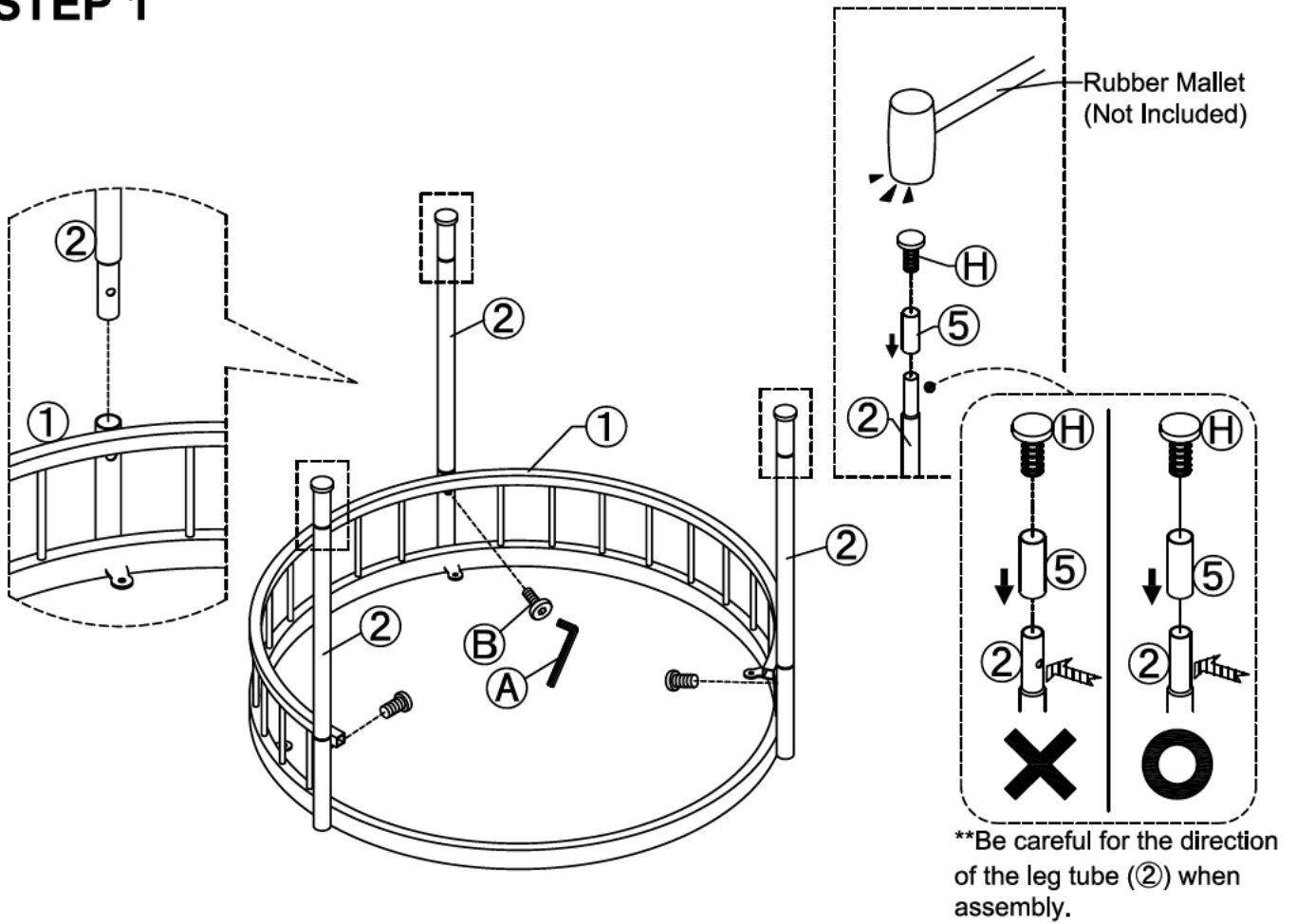

## STEP 2

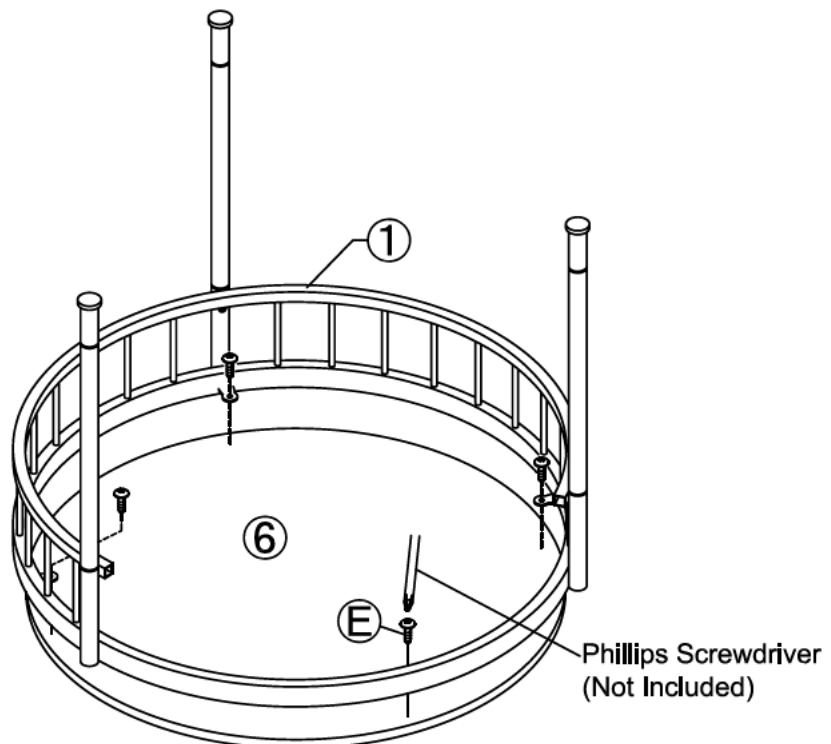

\*\*Attention: Use the carton as a working surface to prevent table-top (6) damage during assembly.

### STEP 3

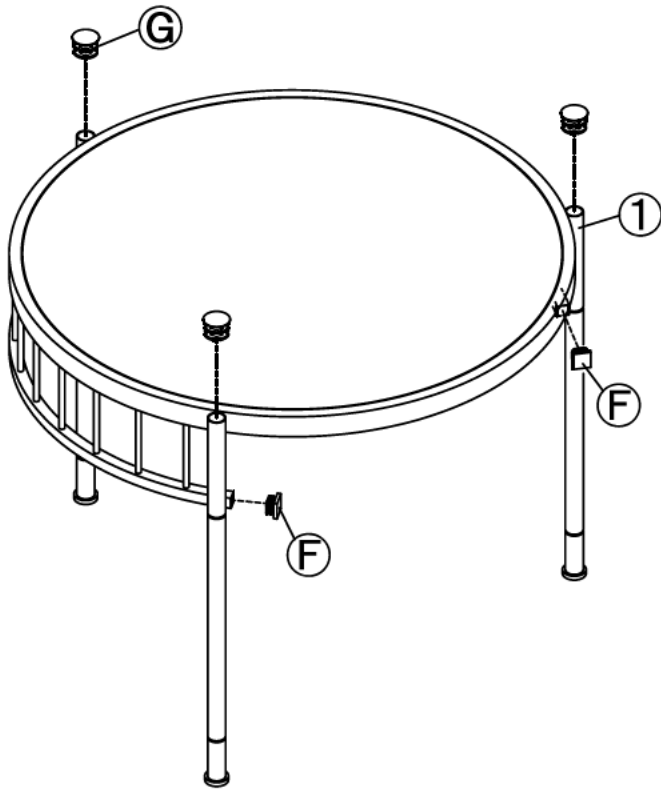

### STEP 4

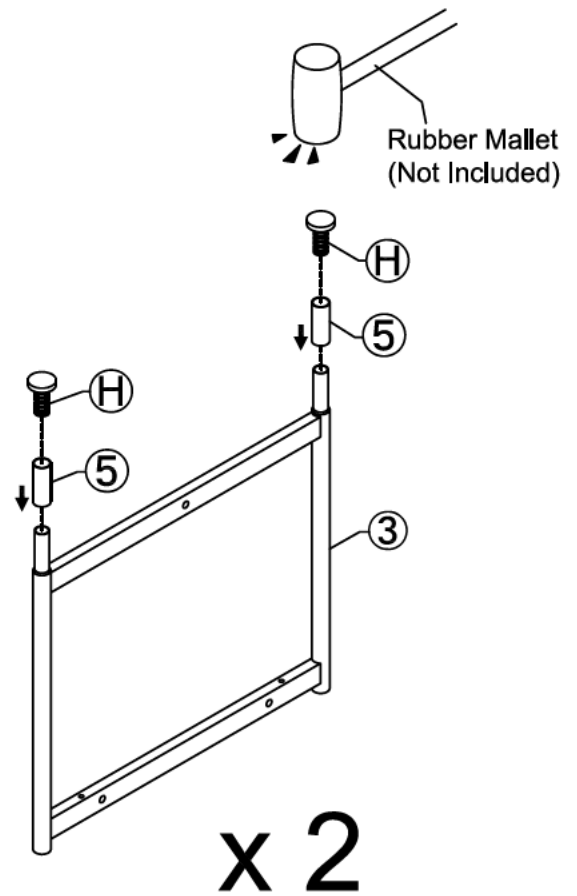

### STEP 5

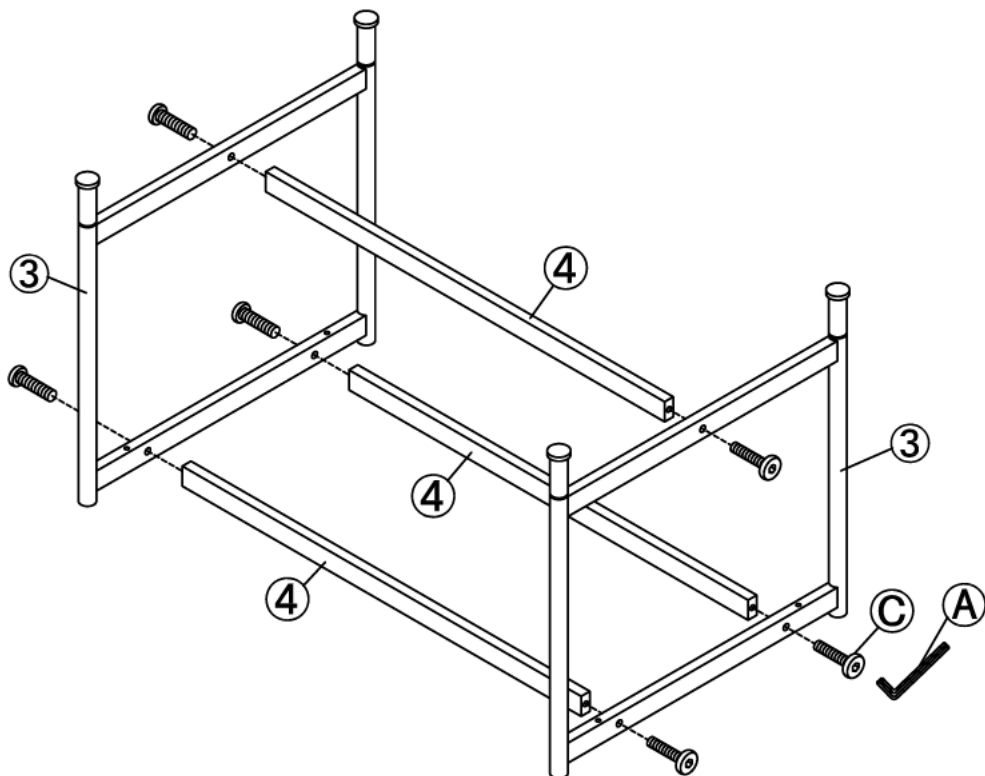

## STEP 6

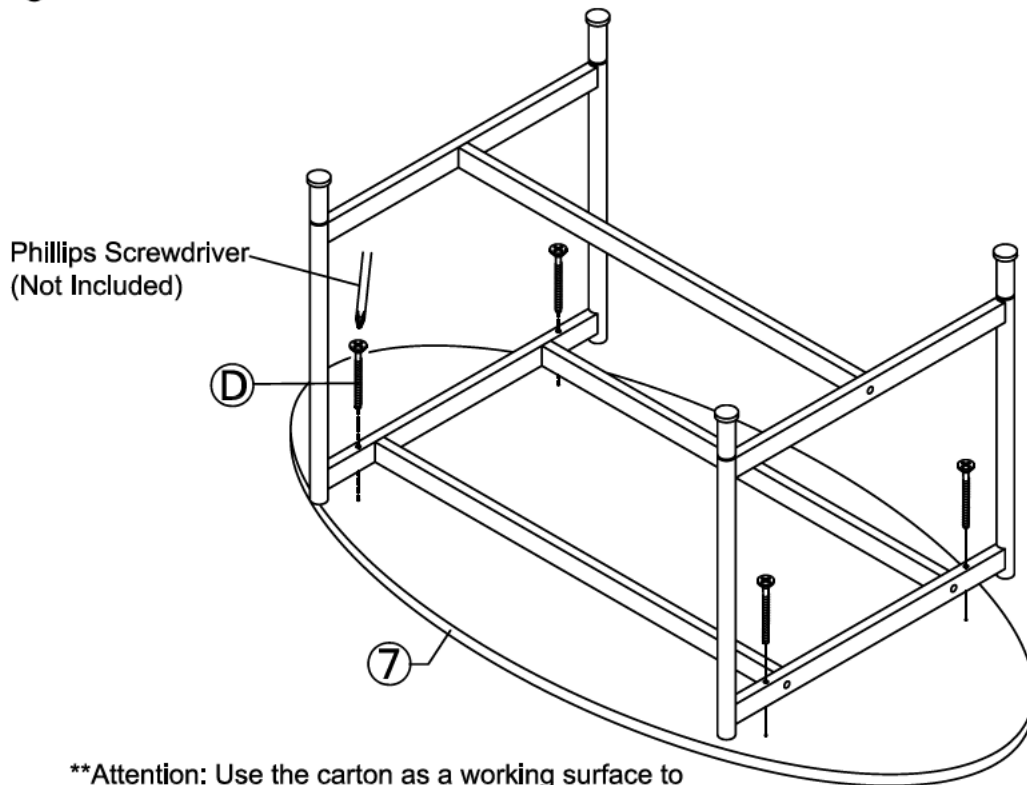

## STEP 7

