

ASSEMBLY INSTRUCTION
INSTRUCTIONS DE MONTAGE

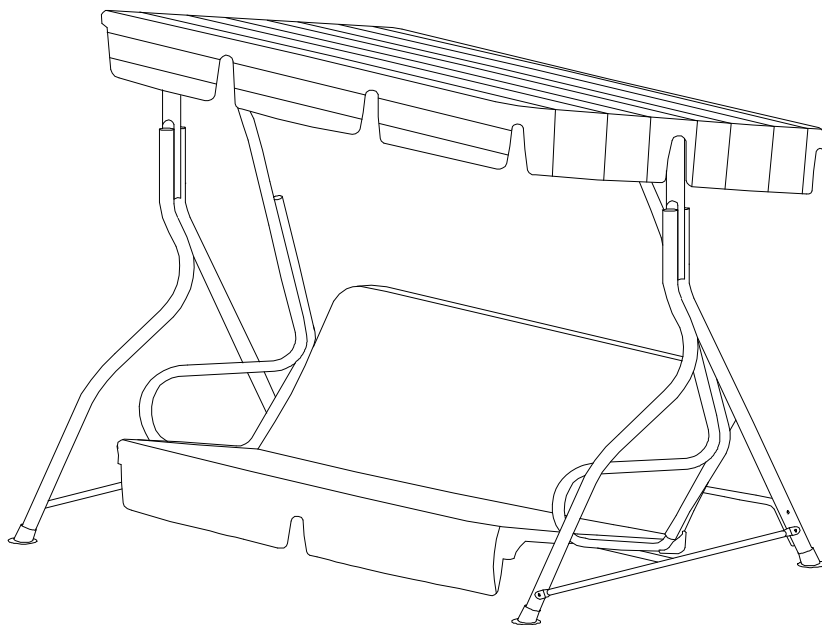

Safety Information / Information sur la sécurité

- One person is required for this assembly.
- Some parts may contain sharp edges. Wear protective gloves.
- When assembling and using this product, basic safety precautions should always be followed to reduce the risk of personal injury and damage to equipment. Please read all instructions before assembly and usage.
- Une personne est requise pour ce montage.
- Certaines pièces peuvent avoir des bords tranchants. Veuillez porter des gants de protection.
- Lors du montage et de l'emploi de cet article, il faudra toujours suivre les précautions de sécurité fondamentales pour réduire le risque de blessures et dommages à l'équipement. Veuillez lire toutes les instructions avant le montage et l'emploi.



CAUTION: Chair is for setting purpose only. Standing on or misuse of chair may result in damage or injury. Not intended for commercial use.
WEIGHT LIMIT 250LBS(113.5KG)

PRECAUTION: La chaise est uniquement pour s'asseoir. Se tenir debout sur la chaise ou un emploi irrégulier peut causer des dommages ou des blessures.
Ne pas utiliser pour emploi commercial.
LIMITE DE POIDS 250LBS (113,5KG)

NOTICE: For outdoor use only.
AVIS: Pour emploi extérieur uniquement.



WARNING/ATTENTION:

Keep all children and pets away from assembly area. Children and pets should be supervised when they are in the area of the Chair construction.

Keep assembly area at least 6 feet from any obstruction such as a fence, garage, house, overhanging branches, laundry line or electrical wires.

Check all bolts for tightness before use. IMPORTANT - check and tighten bolts often to keep them secure!

Gardez tous les enfants et animaux à l'écart de la zone de montage. Les enfants et les animaux doivent être surveillés lorsqu'ils se trouvent près de la zone de construction de la chaise.

Gardez la zone de montage à au moins 6 pieds de toute obstruction telle qu'une clôture, un garage, une maison, des branches pendantes, corde à tendre ou câbles électriques.

Vérifiez que tous les boulons soient serrés avant l'emploi. IMPORTANT - vérifiez et serrez souvent les boulons pour les maintenir serrés!

**Warranty: 6 MONTHS
Garantie: 6 mois**

**WHAT IS COVER?
CE QUI EST COUVERT PAR LA GARANTIE**

The limited warranty is extended to the original purchaser and applies to material and manufacturer's defect provided the item is maintained with care and used only for personal, residential purposes.

La garantie limitée n'est attribuée qu'à l'acheteur d'origine et s'applique aux défauts matériaux et du fabricant à condition que l'article soit entretenu avec soin et utilisé uniquement à des fins personnelles et résidentielles.









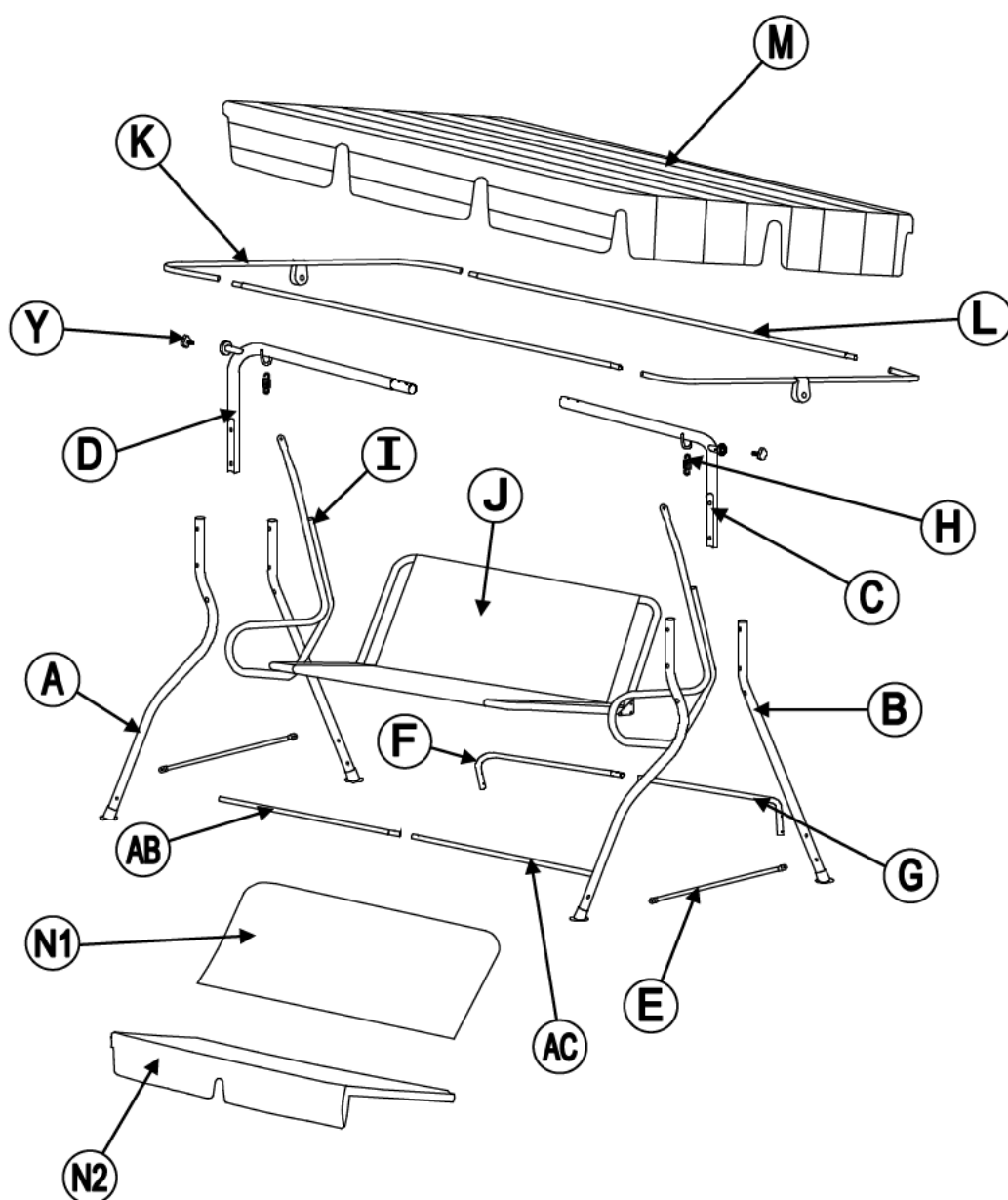









IMPORTANT

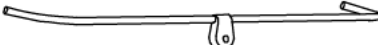

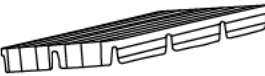



**KEEP THIS INSTRUCTION MANUAL FOR FUTURE REFERENCE.
CONSERVEZ CE MANUEL D'INSTRUCTIONS POUR LE CONSULTER DANS L'AVENIR.**

**How many people needed for the installation work
Combien de personnes seront nécessaires pour le travail
d'installation.**

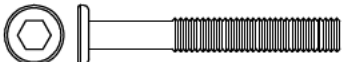
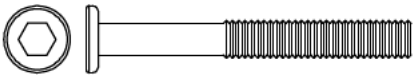
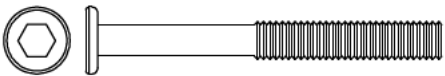
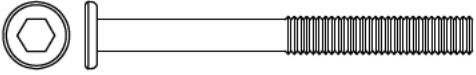
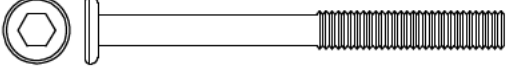

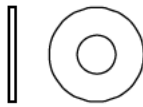
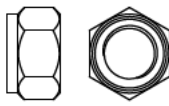
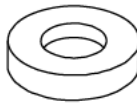
EXPLODED DRAWING / DIAGRAMME AGRANDI

Parts List / Liste de Pièces				
Label Étiquette		Description	Qty Qté	Part Image
A		Front leg Jambe avant	2	
B		Back Leg Jambe arrière	2	
C		Short Top Beam Poutre supérieure courte	1	
D		Long Top Beam Poutre supérieure longue	1	
E		Bottom Support Tube Tuyau de Support Inférieur	2	
F		Back Support 1 Support dorsal 1	1	
G		Back Support 1 Support dorsal 1	1	
H		Hook Crochet	2	
I		Handrail Balustrade	2	
J		Seat Siège	1	
K		U-Shape Tube Tube en forme de U	2	
L		Canopy Support Support de canopée	2	
M		Canopy Canopée	1	
N1		Back Cushion Coussin de dossier	1	
N2		Seat Cushion Coussin de siege	1	
AB		Middle Connect Bar (Long) Barre de connexion centrale (Longue)	1	
AC		Middle Connect Bar (Short) Barre de Connexion Centrale (courte)	1	
Y		Knob Bouton	2	

Hardware Pack / Pack Quincaillerie				
Label Étiquette	Description	Qty Qté	Add	Part Image
O	Bolt M6*30 Boulon M6*30	4	1	
P	Bolt M6*45 Boulon M6*45	2	1	
Q	Bolt M6*60 Boulon M6*60	2	1	
R	Bolt M6*63 Boulon M6*63	4	1	
R1	Bolt M6*68 Boulon M6*68	4	1	
S	Bolt M6*85 Boulon M6*85	2	1	
T	Bolt M6*90 Boulon M6*90	4	1	
U	Flat washer M6 Rondelle plate M6	22	3	
V	Nut M6 Écrou M6	22	3	
W	Flat plastic washer M6 Rondelle plastique plate M6	6	1	
X	Ball head nut M6 Écrou à tête sphérique M6	22	3	
AA	Allen Key Size 4 Clé Allen taille 4	1	0	
BB	Wrench M6 Clé M6	1	0	
CC	Bolt M6*50 Boulon M6*50	2	1	

1

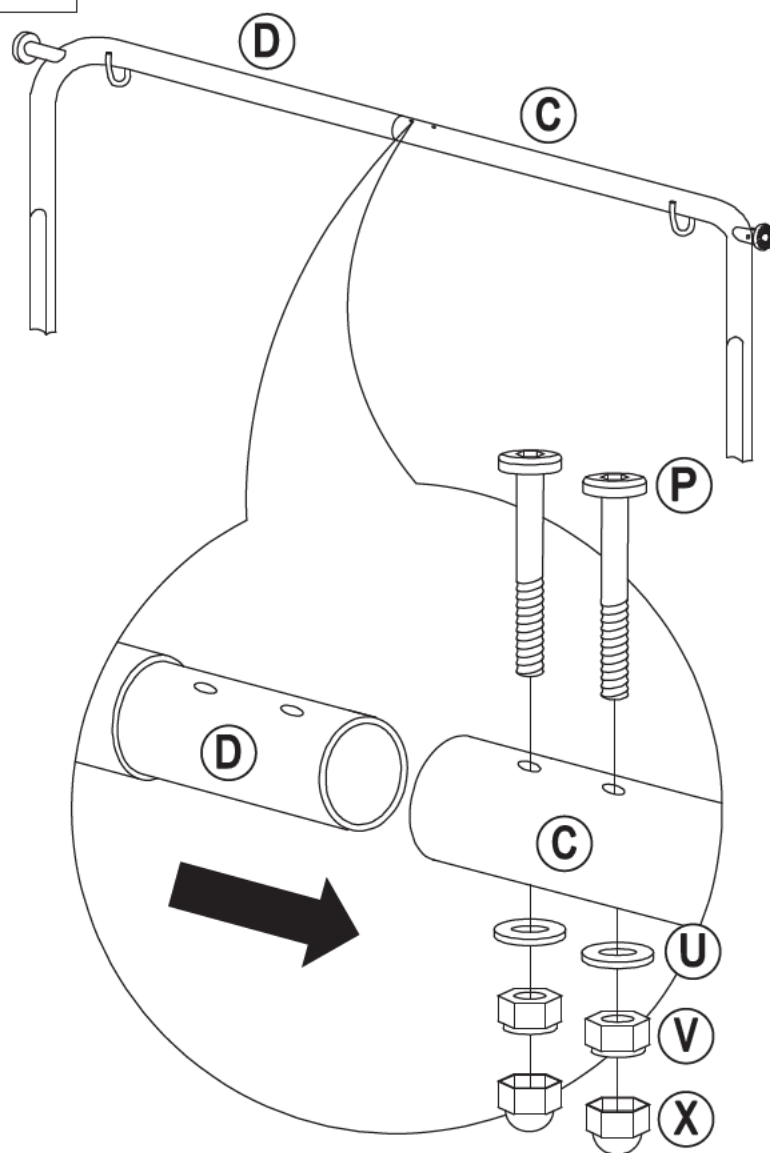
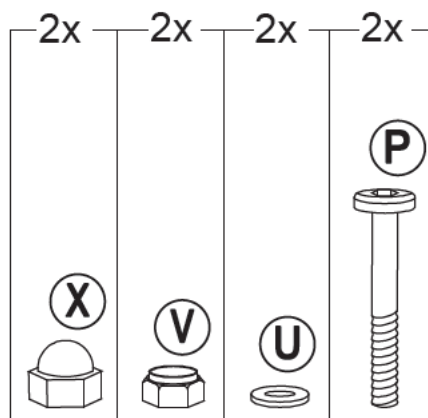
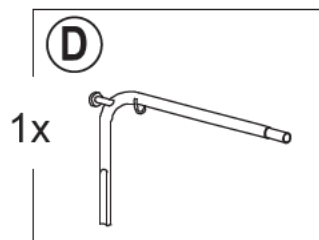
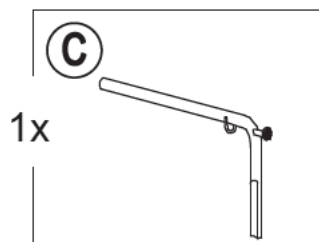

2

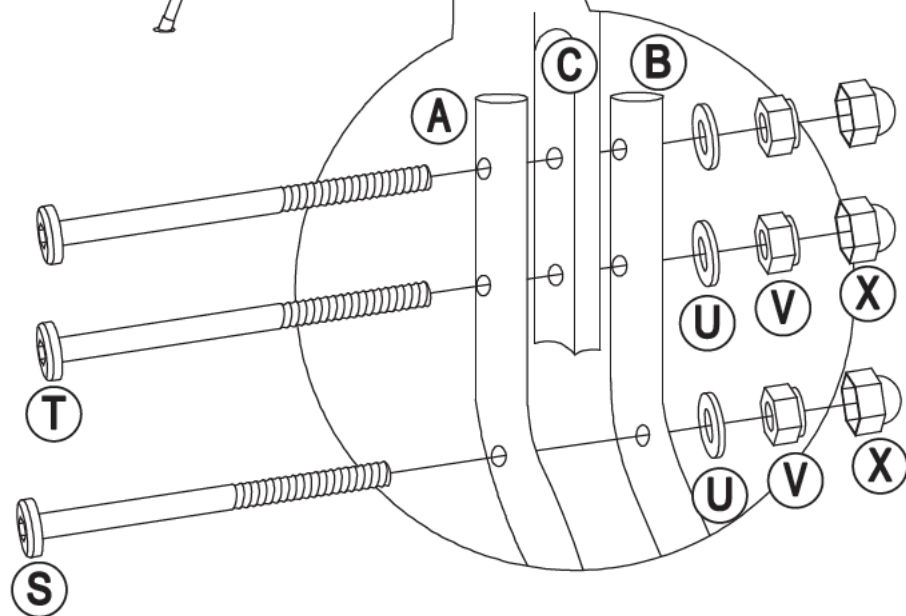
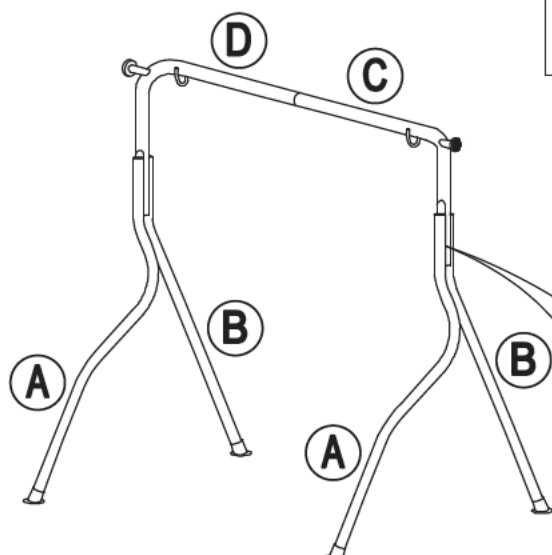
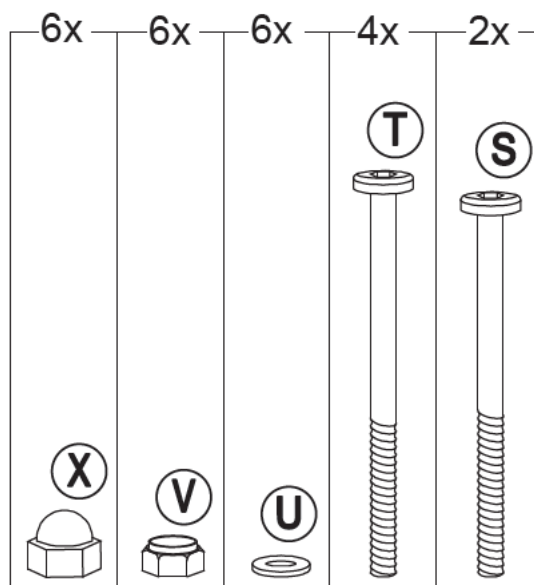
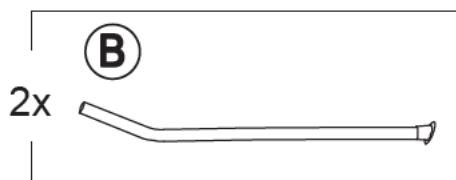
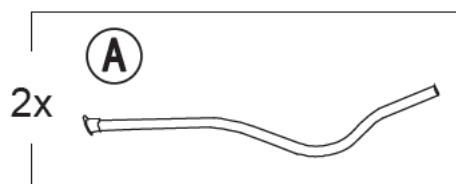

3

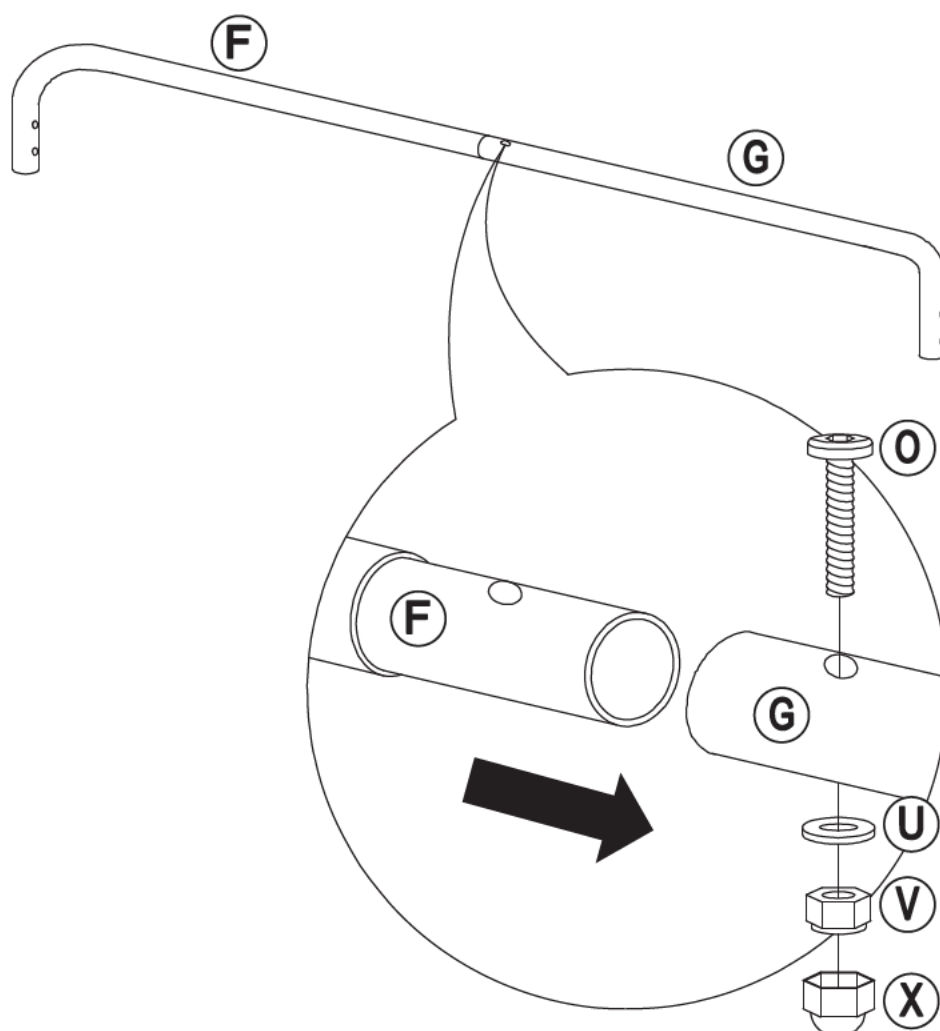
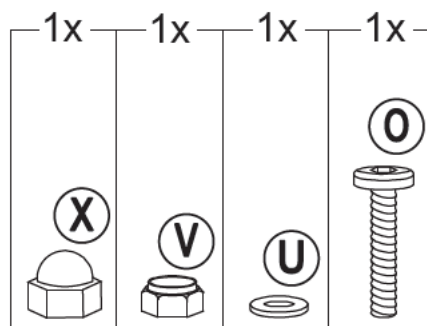
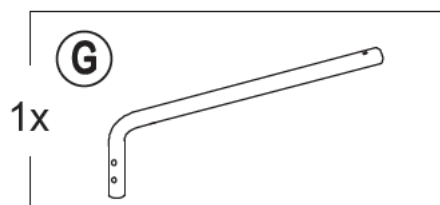
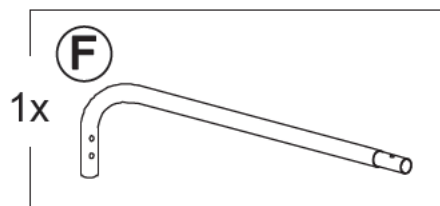

4

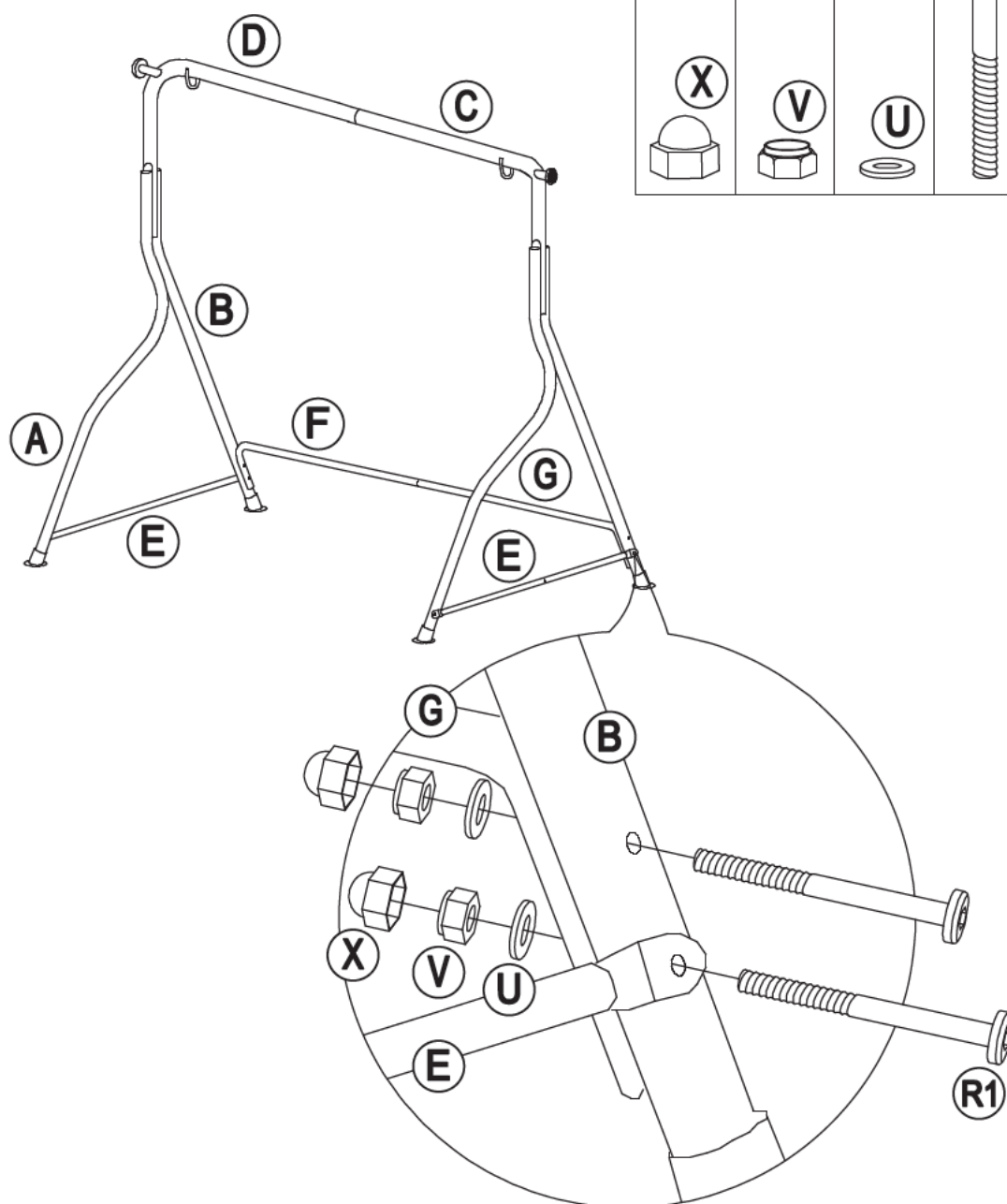
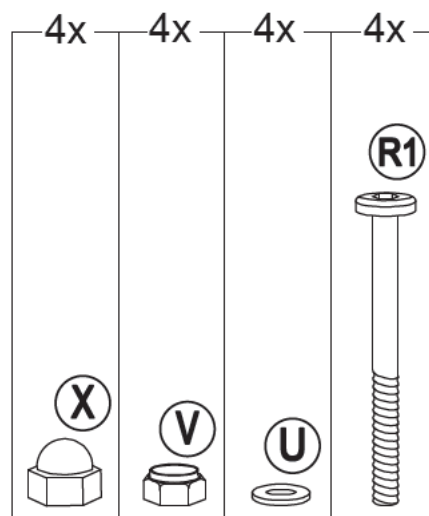
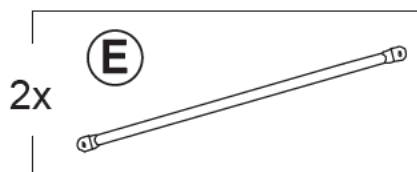

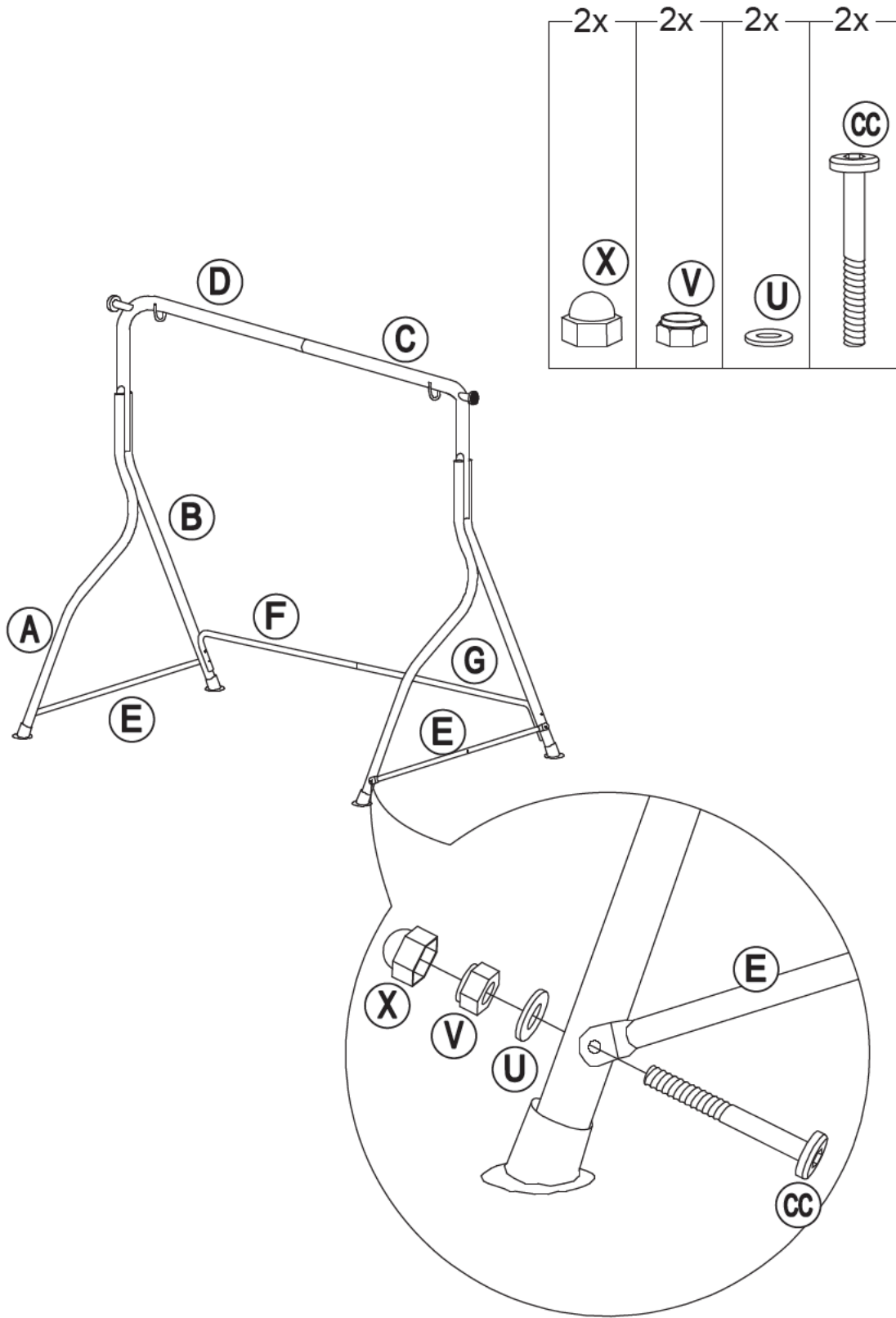

6

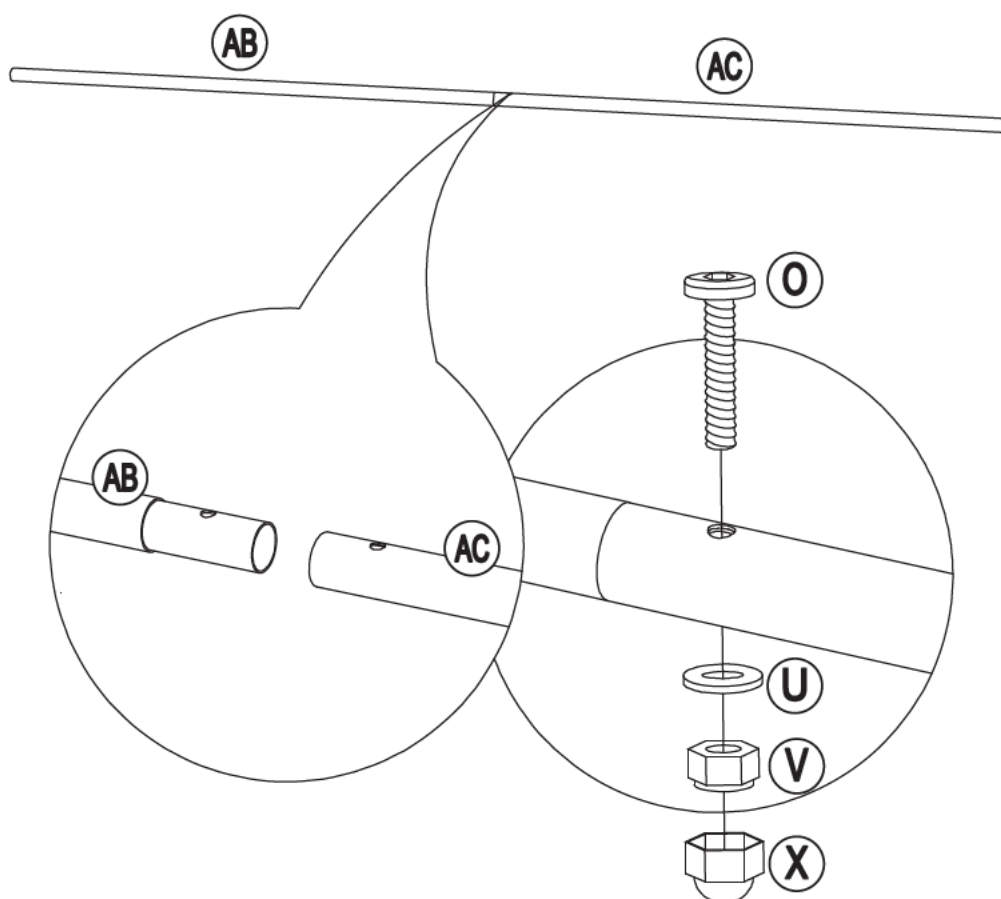
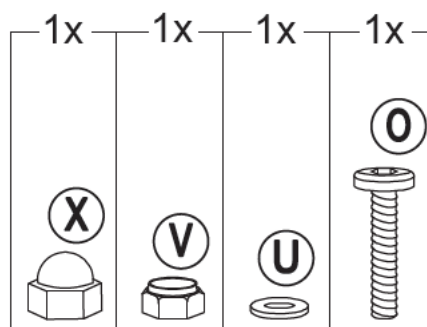
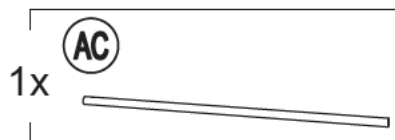
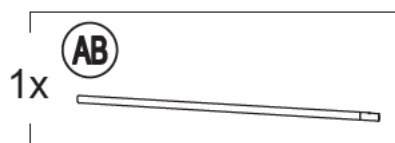

7

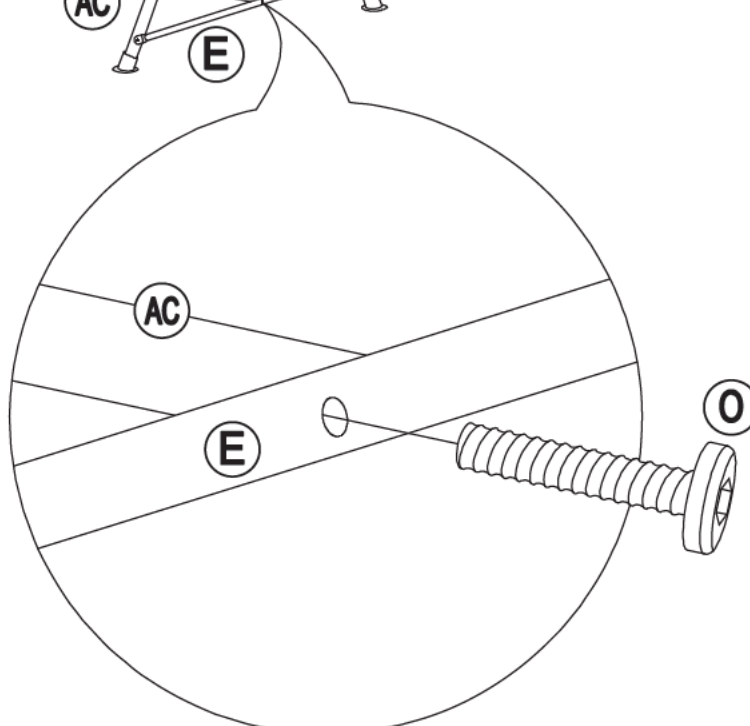
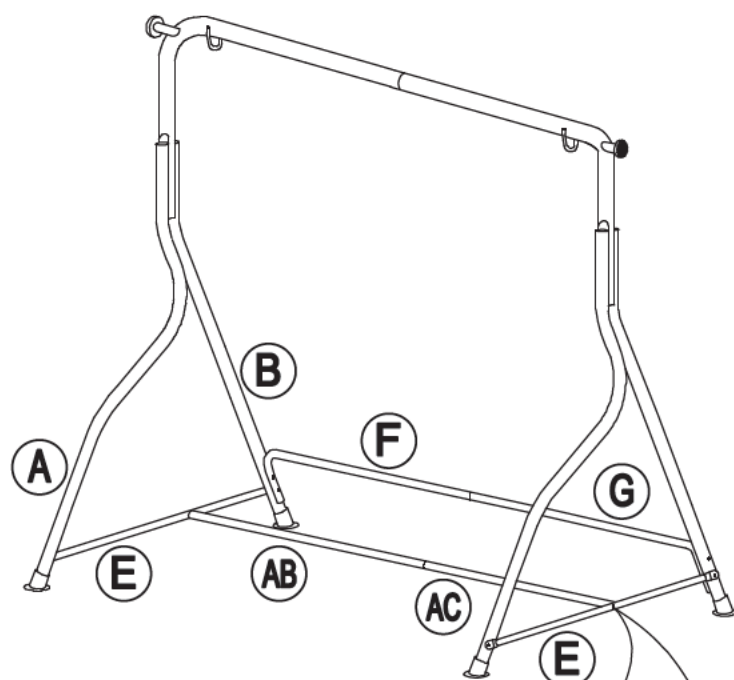
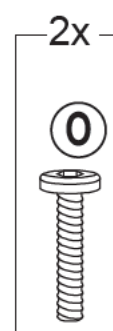

8

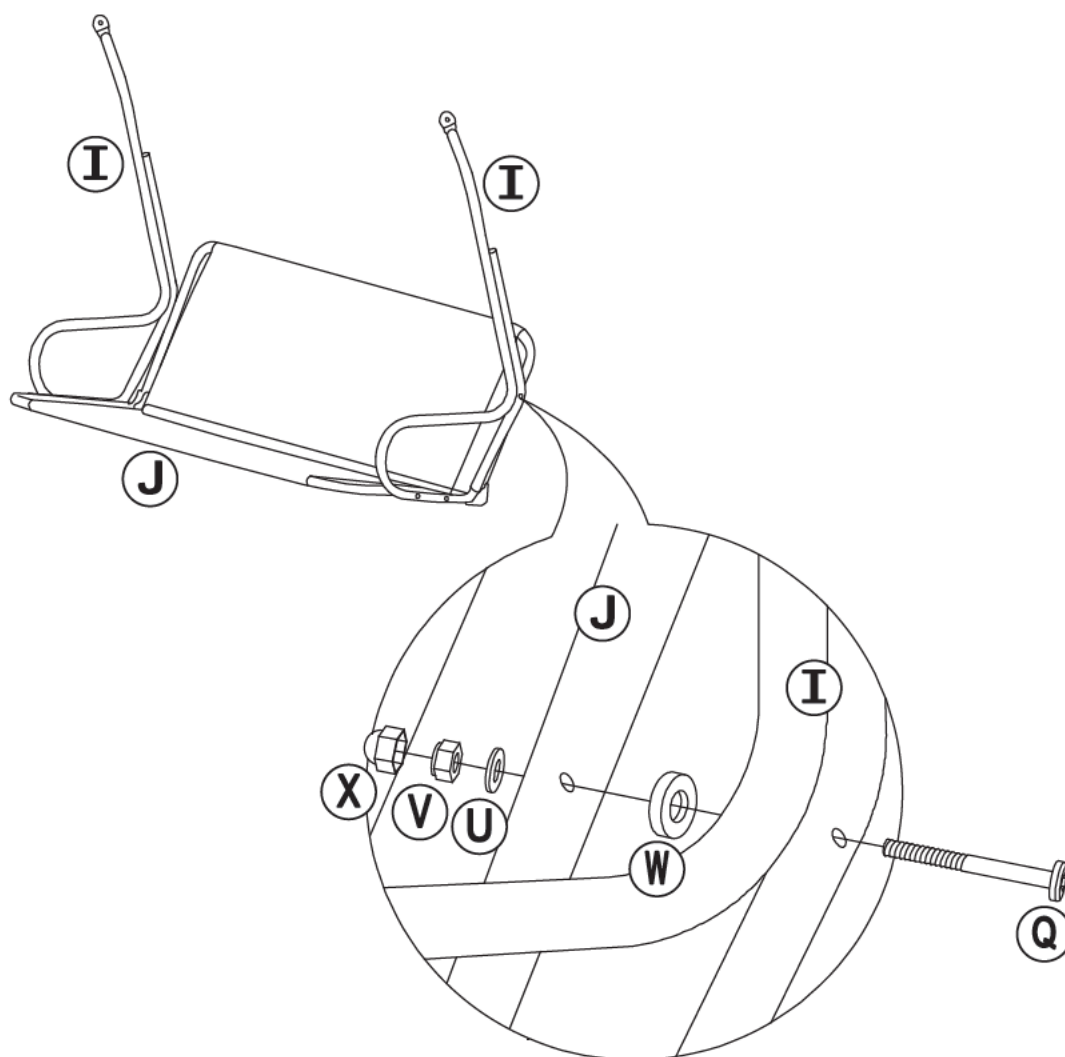
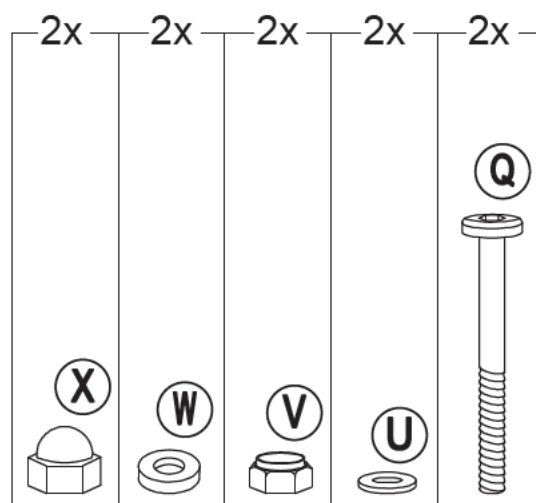
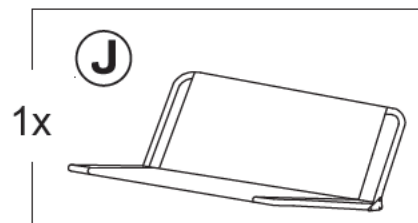
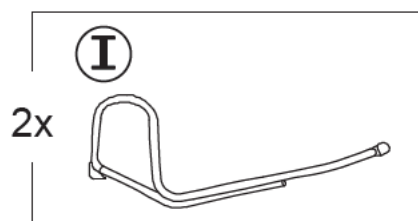

9

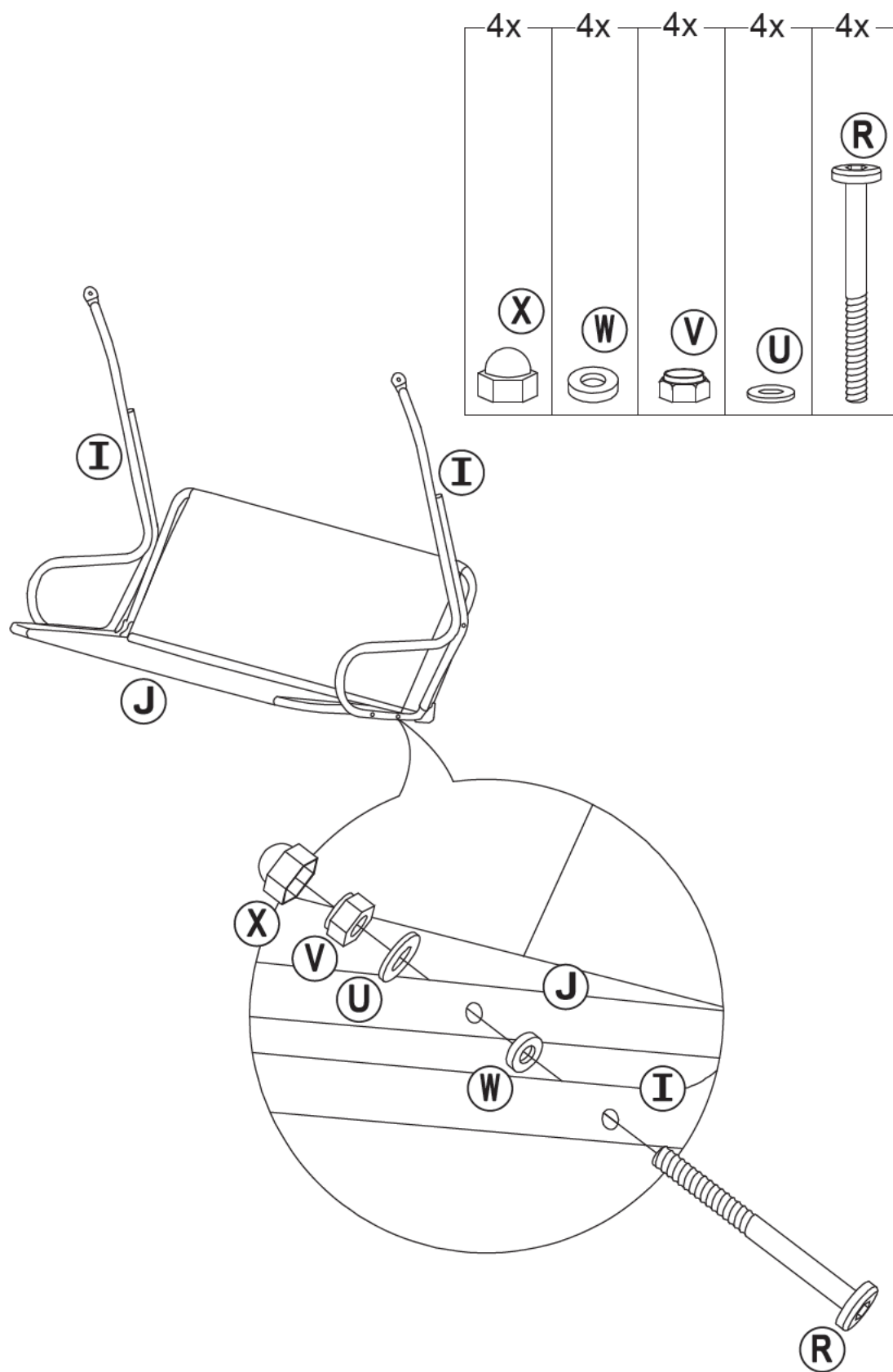

10

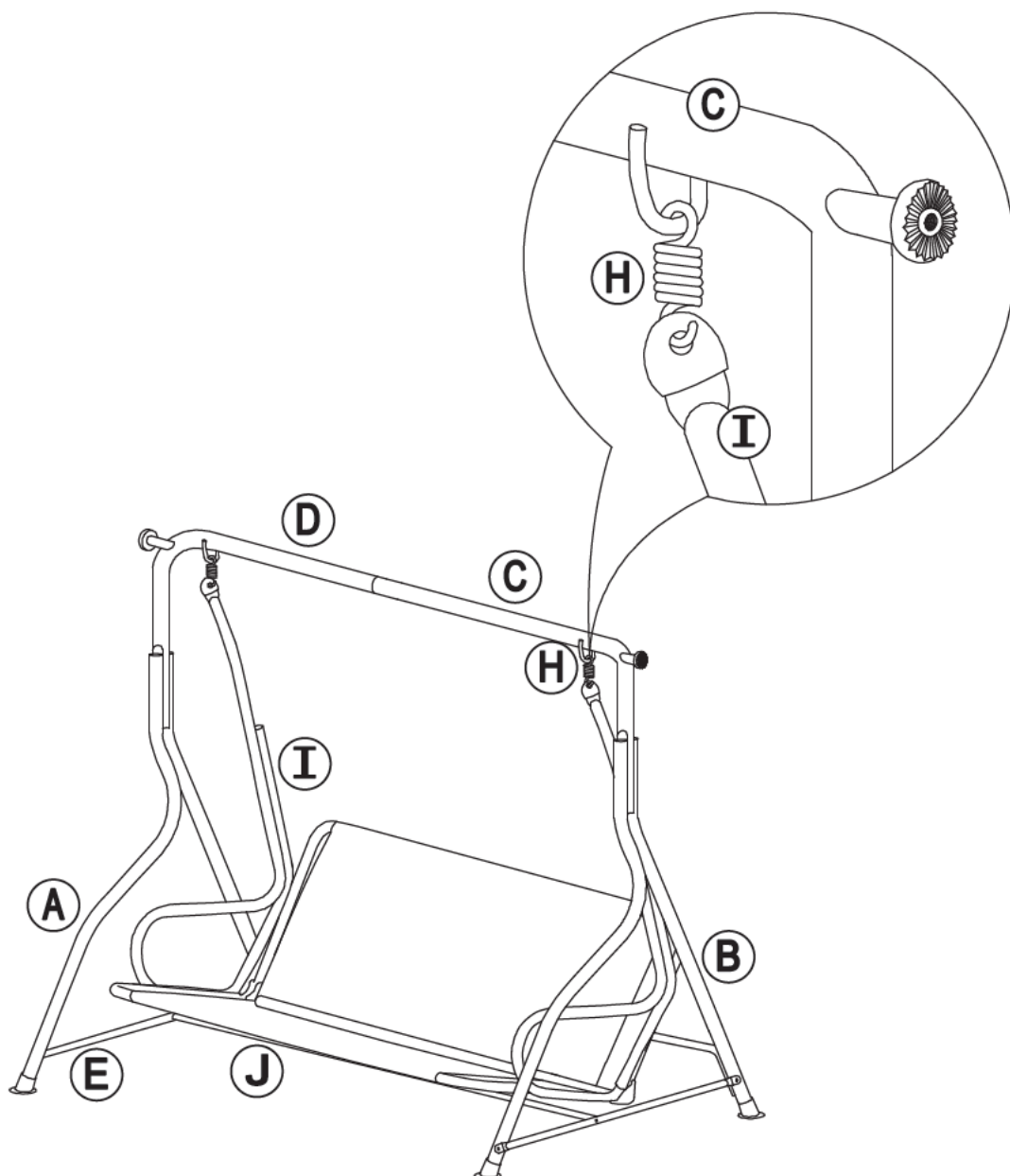
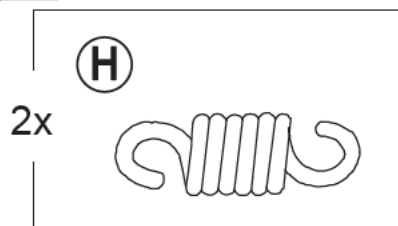

11

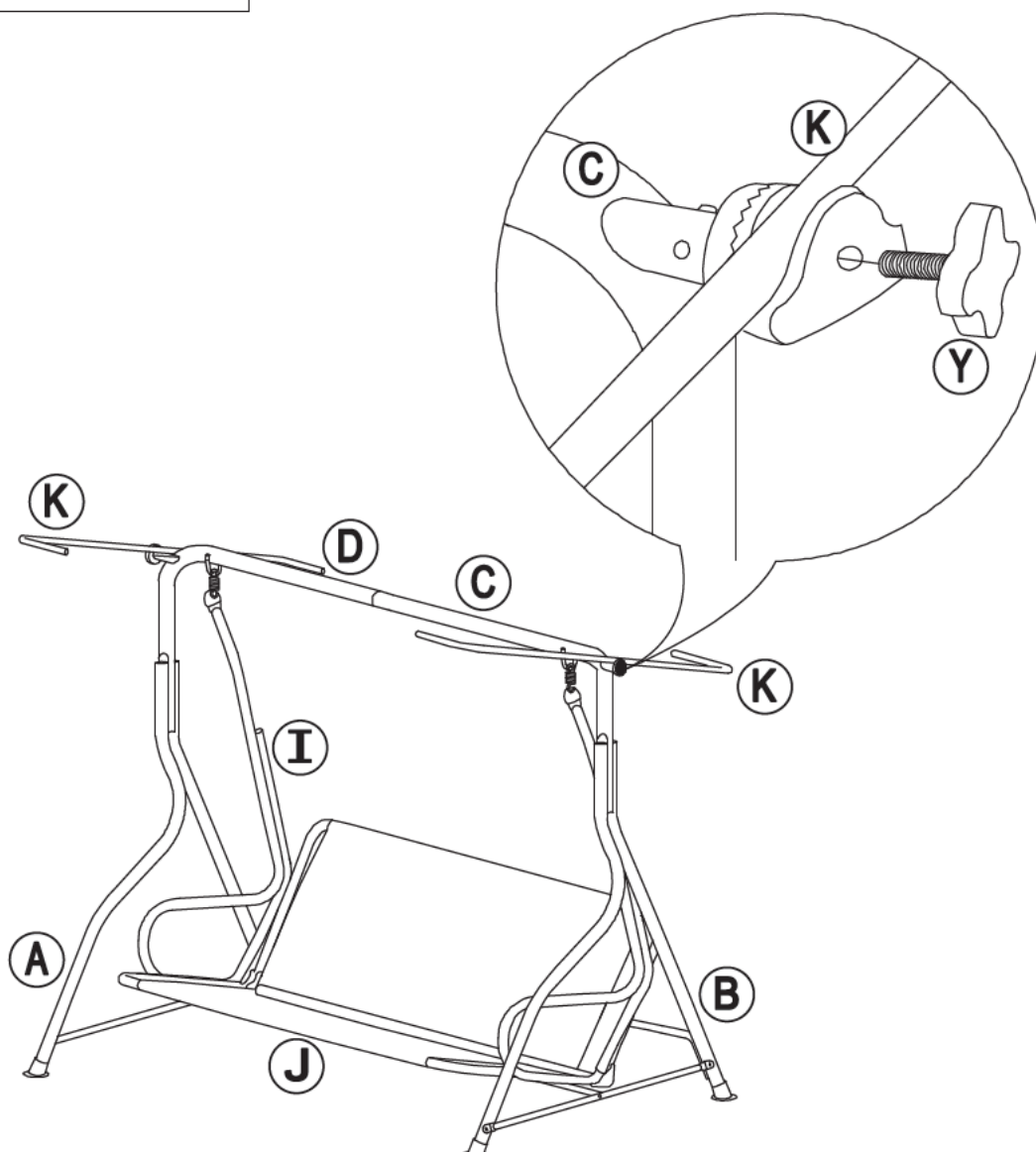
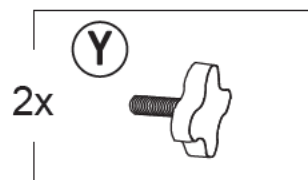
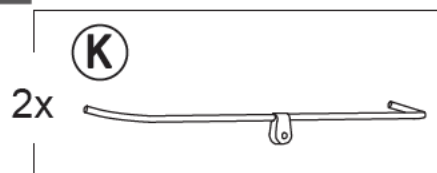

12

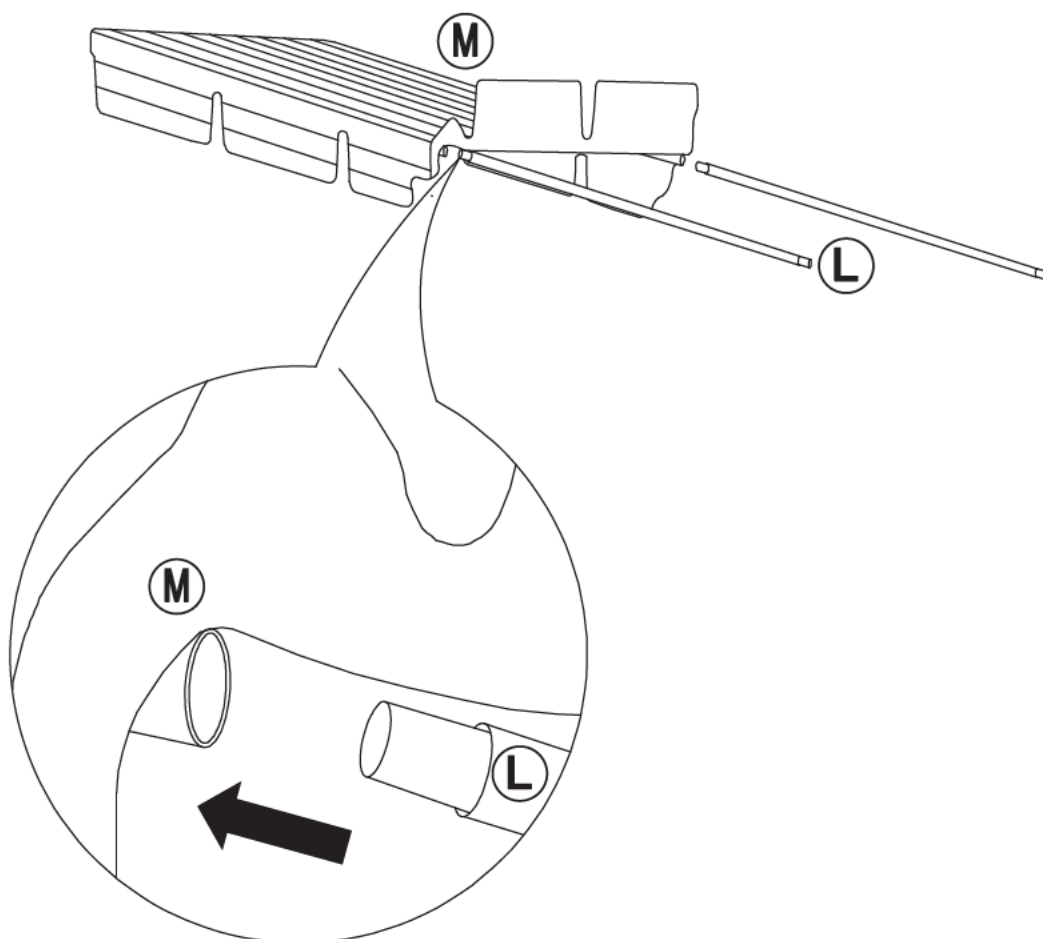
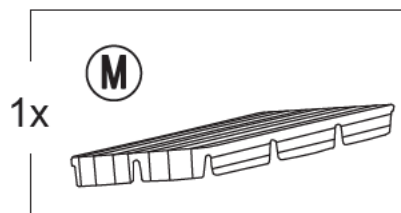
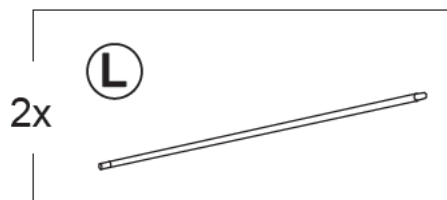

13

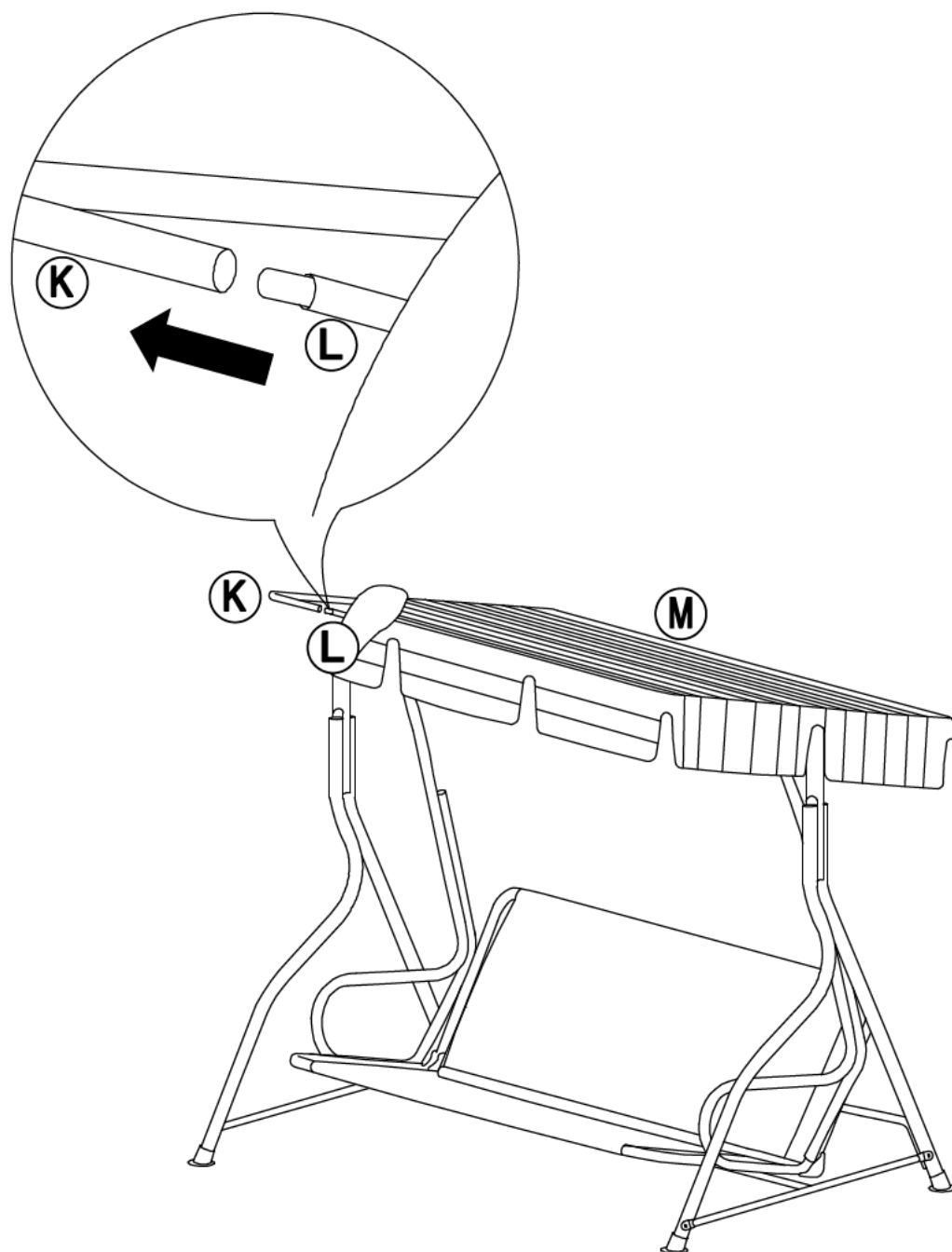

14

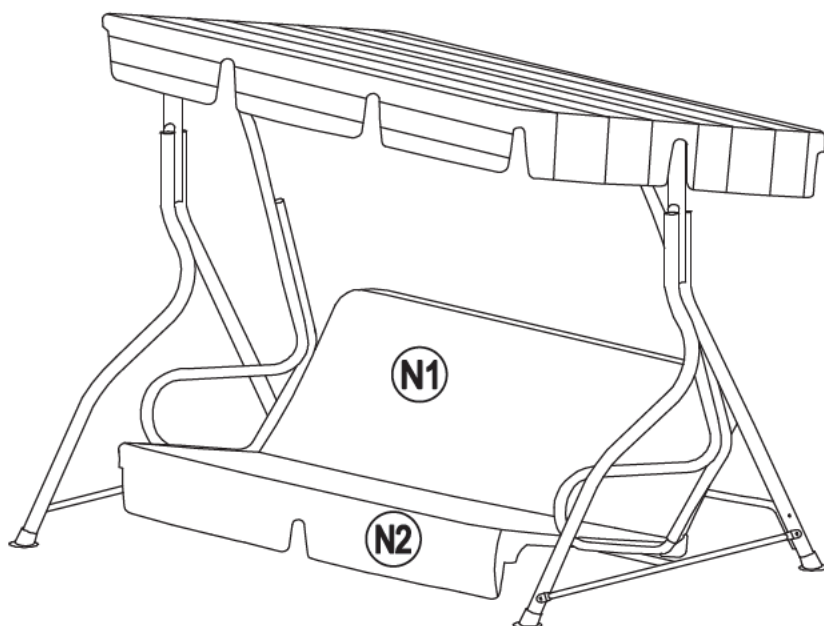
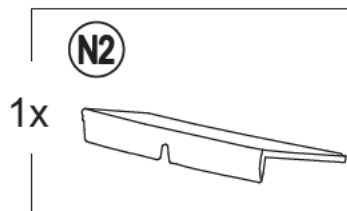
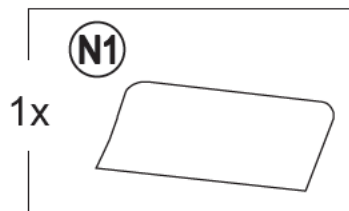

Care and Maintenance / Soins et Entretien

Before using, clean the Chair completely with a soft dry towel. When not in use, wipe free of any dirt or loose objects, wash with a mild solution of soap and water; rinse thoroughly and dry completely. Do not use strong detergent or abrasive cleaners. Over time nuts and bolts can loosen. Occasionally, check nuts and bolts, re-tighten if necessary.

Avant d'utiliser, nettoyez le fauteuil complètement avec une serviette douce. Pendant que vous ne l'utilisez pas, nettoyez toute saleté ou retirez les objets, lavez avec une solution légère de savon et d'eau ; rincez et séchez complètement. N'utilisez pas de détergents forts ou de nettoyeurs abrasifs. Avec le temps les boulons et les écrous peuvent se desserrer. Vérifiez les boulons et les écrous de temps en temps et resserrez-les si c'est nécessaire.

Limited Manufacturer's Warranty / Garantie Limitée du Fabricant

We warrant to the original purchaser that this item is free from defects in workmanship and materials for a period of six months from the date of purchase, provided the item was factory-sealed at the time of purchase and is maintained with care and used only for personal, residential purposes. Should any manufacturing defect arise within this warranty period, we will replace (at our option) any defective merchandise or parts upon proof of purchase; however, transportation and delivery costs, as well as payments to a third party for assembly or disassembly of the item, remain the responsibility of the purchaser. A purchaser of an "open box," previously-returned, or "clearance" item, as well as original purchasers outside of the warranty period, may obtain replacement parts from us for products in current production, at nominal cost.

Nous garantissons à l'acheteur original que cet article est exempt de défauts en main d'œuvre et en matériaux pour une période de six mois depuis la date d'achat, pourvu que l'article soit maintenu avec soin et utilisé pour emploi personnel, résidentiel. Si vous détectez un défaut dans la période de garantie, nous remplacerons (à votre option) toute marchandise ou les pièces défectueuses en présentant la preuve d'achat : Cependant, les frais de transport et de livraison, autant que les honoraires payés à un tiers pour le montage ou démontage de l'article, seront la responsabilité de l'acheteur. Un acheteur d'une "" boîte ouverte "" précédemment retournée, ou un article "" en liquidation "", ainsi que les acheteurs originaux en dehors de la période de garantie, peuvent obtenir des pièces de rechange pour les produits en production actuelle, à un prix actuel.