

Assembly Instructions

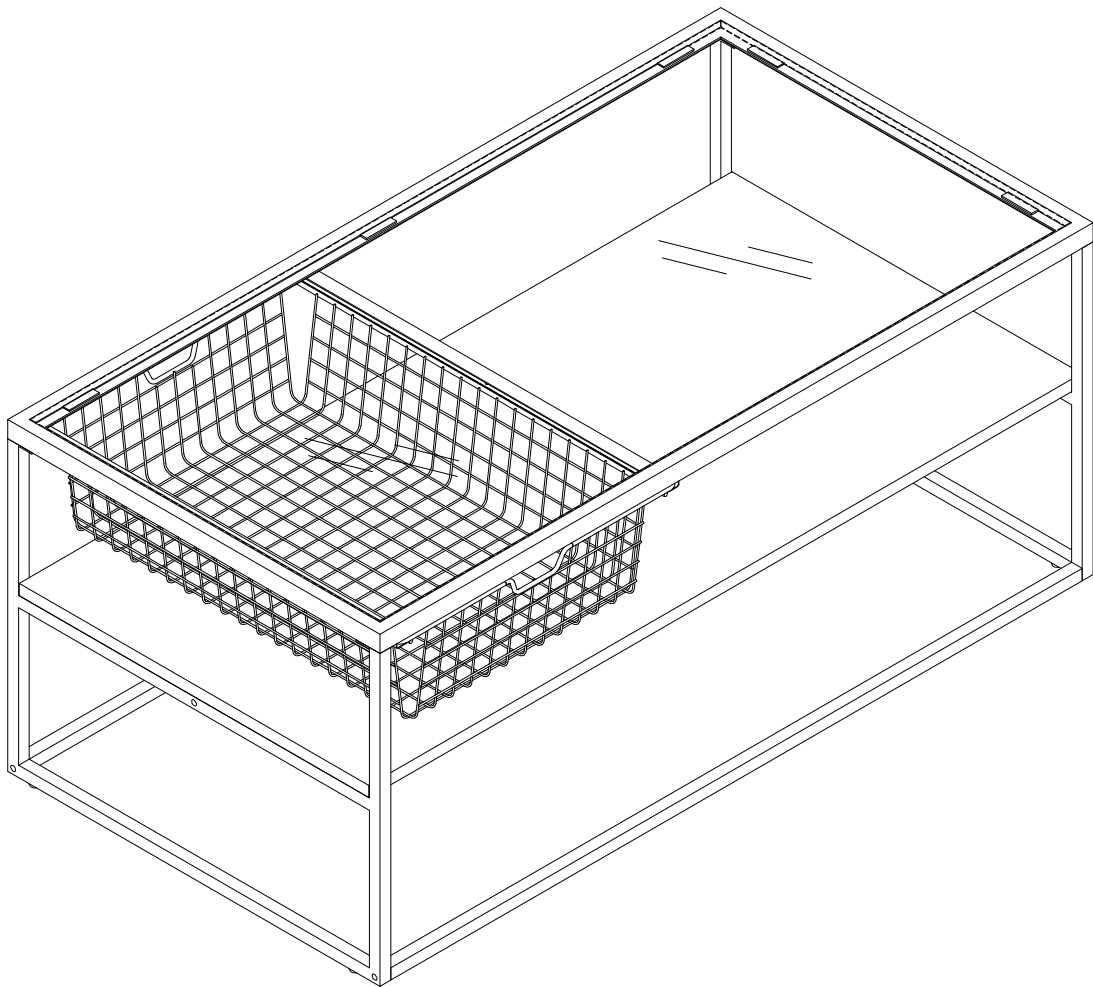

General Assembly Guidelines

- I. Ensure that all parts and hardware are available before beginning assembly.
- II. Follow each step carefully to ensure the proper assembly of this product.
- III. Two people are recommended for ease in the assembly of this product.
- IV. The three main types of hardware used to assemble this product are: wood dowels, screws and bolts.
- V. The provided glue is to secure wood dowels in place. When first inserting dowels, locate the appropriate hole for the dowel, place a small amount of glue in the hole and insert the dowel. Wipe away excess glue immediately.

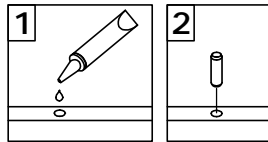

In future assembly steps when dowels are necessary to attach assembly parts together, place a small amount of glue on the end of the dowel before attaching parts together. Wipe away excess glue immediately.

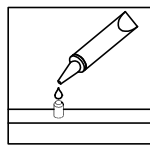

- VI. A Phillips head screwdriver is required for the assembly of this product .

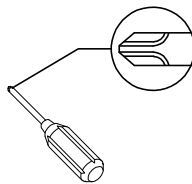

- VII. Power tools should not be used to assemble this product.

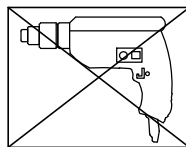

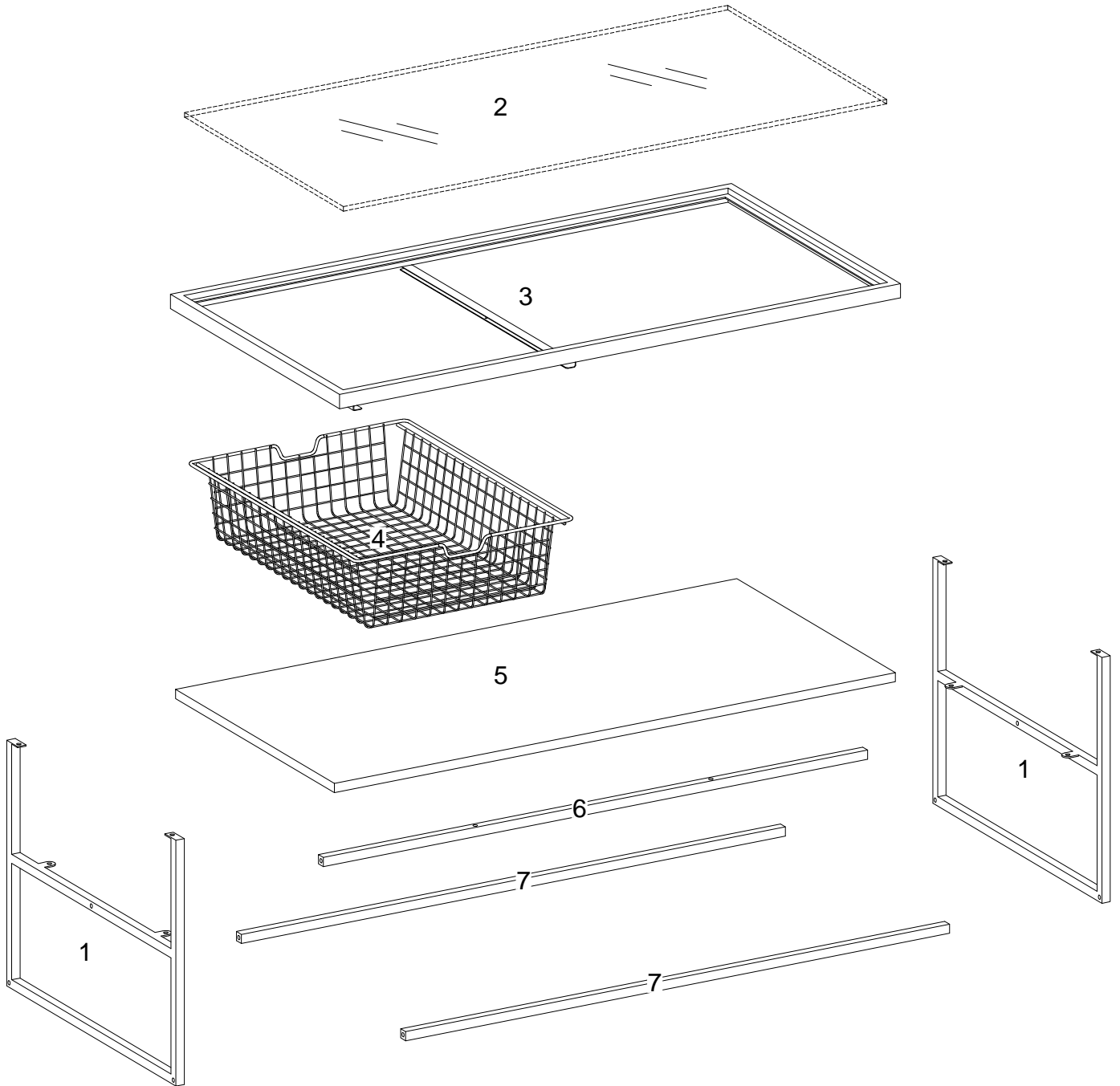

- VIII. Drill may be needed for securing product to wall.

Parts List



Hardware List

A		Ø1/4"x12mm	Bolt	8 pcs
B		Ø1/4"x25mm	Bolt	6 pcs
C		Ø4x12mm	Bolt	2 pcs
D			Glass pads	10 pcs
E			Adjustable foot	4 pcs
F		Ø1/4"x25mm	Bolt	2 pcs
G		M 4	Hex Key	1 pc

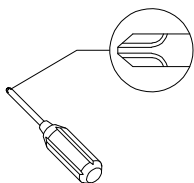

Philips head screwdriver required for assembly
(not included)

*The hardware quantities listed above are required for proper assembly.
Some extra hardware may also have been included.*

Step 1

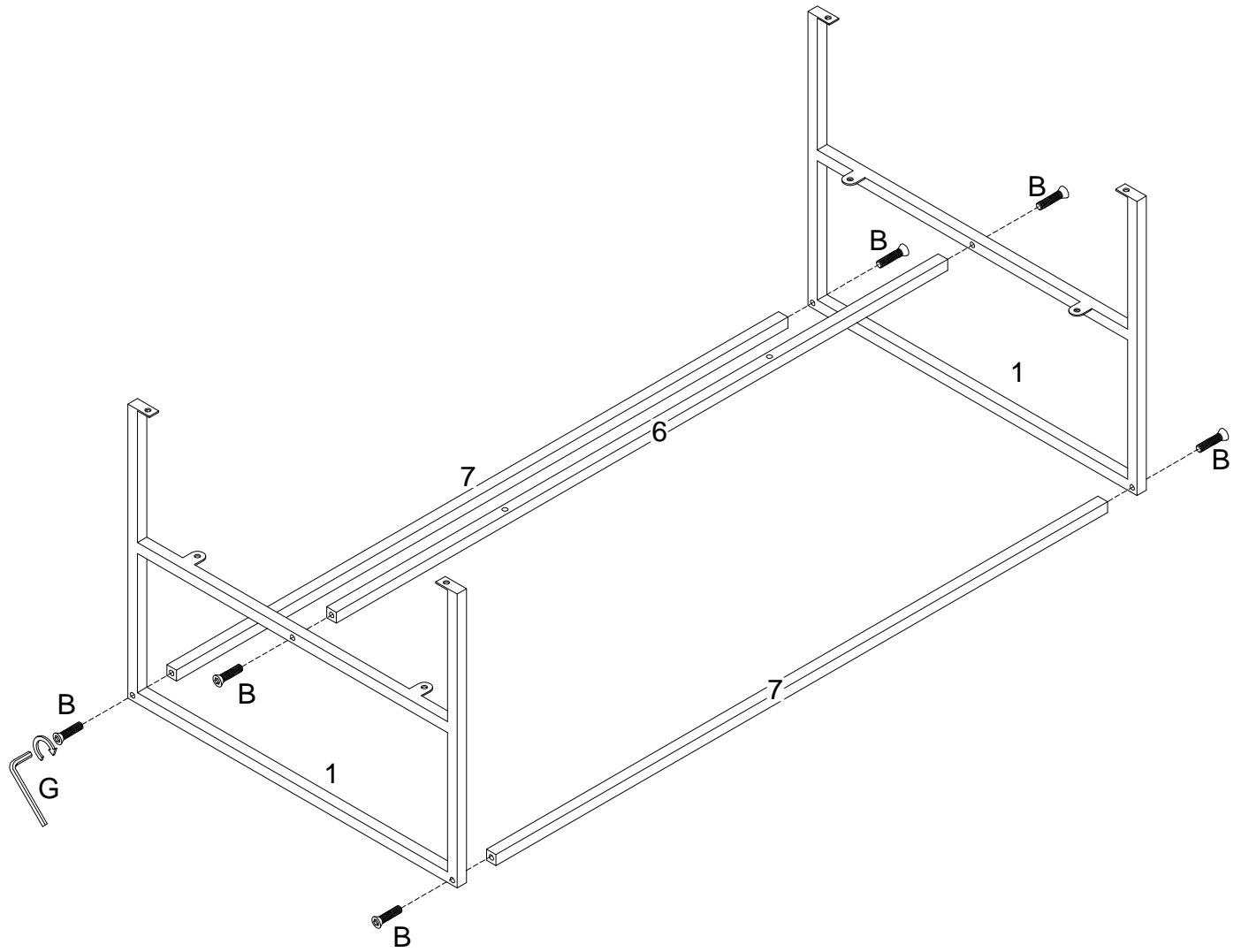

Using bolt (B) attach part (1) to parts (6,7) with Hex key (G) as per diagram.
Note: Do not tighten all the bolts.

Step 2

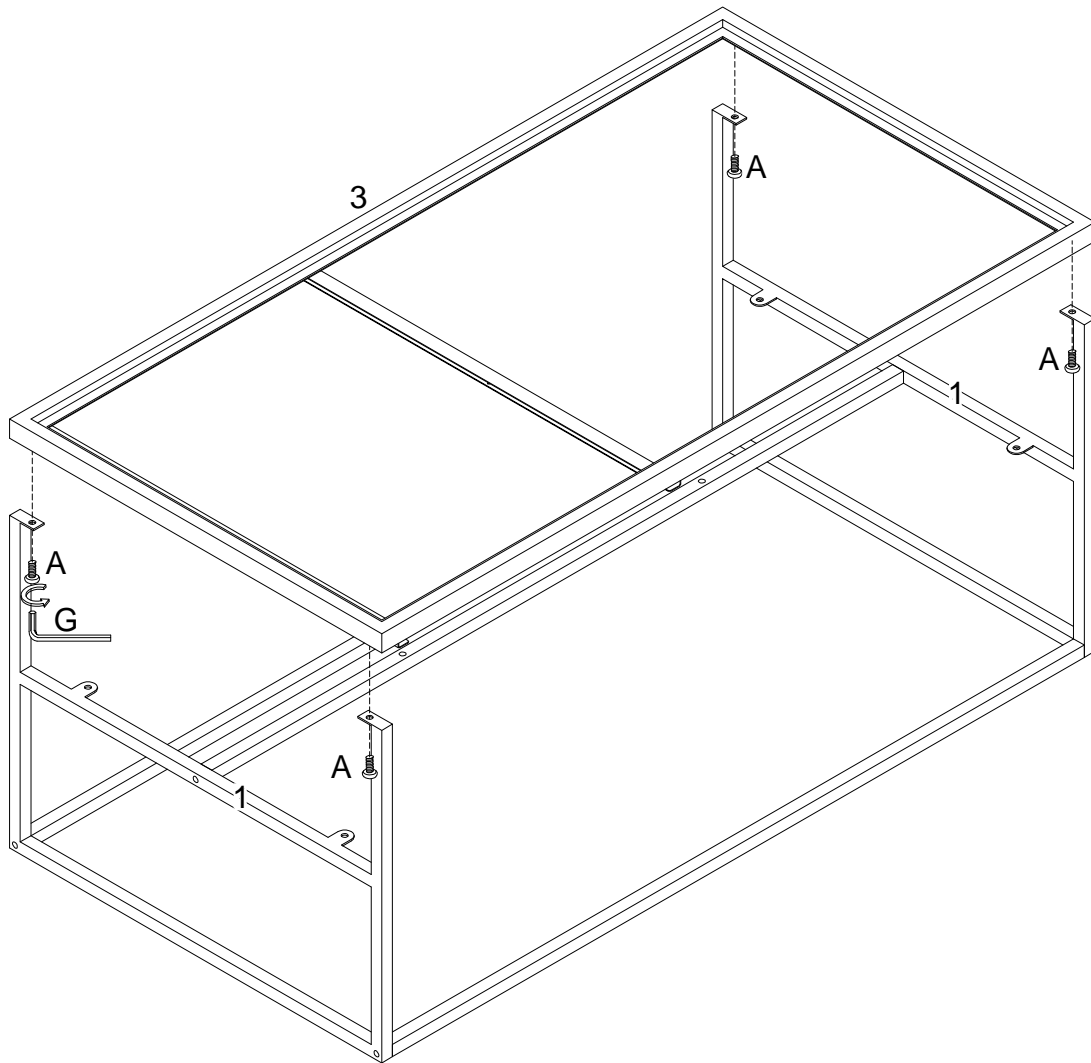

Using bolt (A) attach part (1) to part (3) with Hex key (G) as per diagram.

Step 3

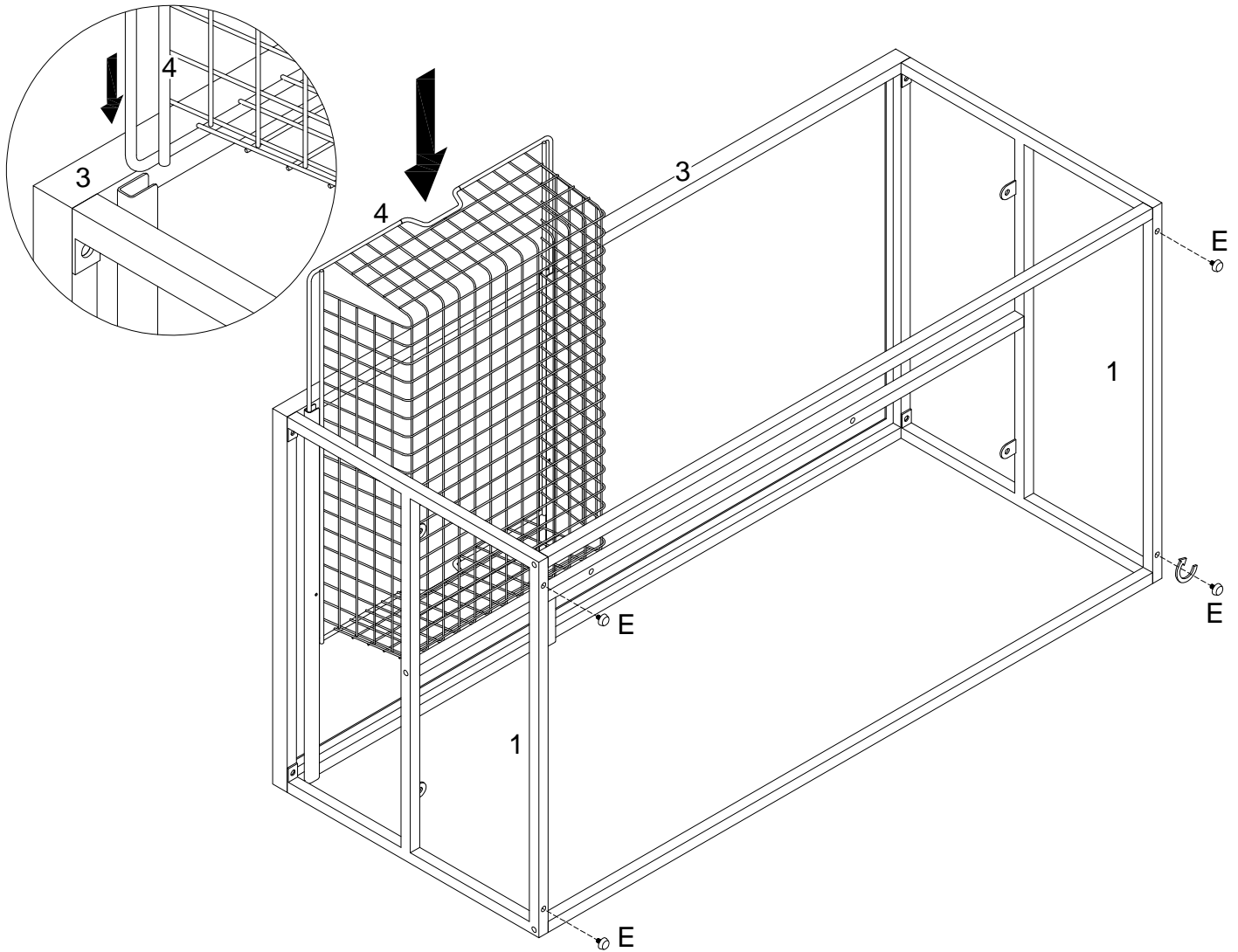

Put part (4) as per diagram. then secure plastic adjustable levelers (E) to part (1) as per diagram.

Step 4

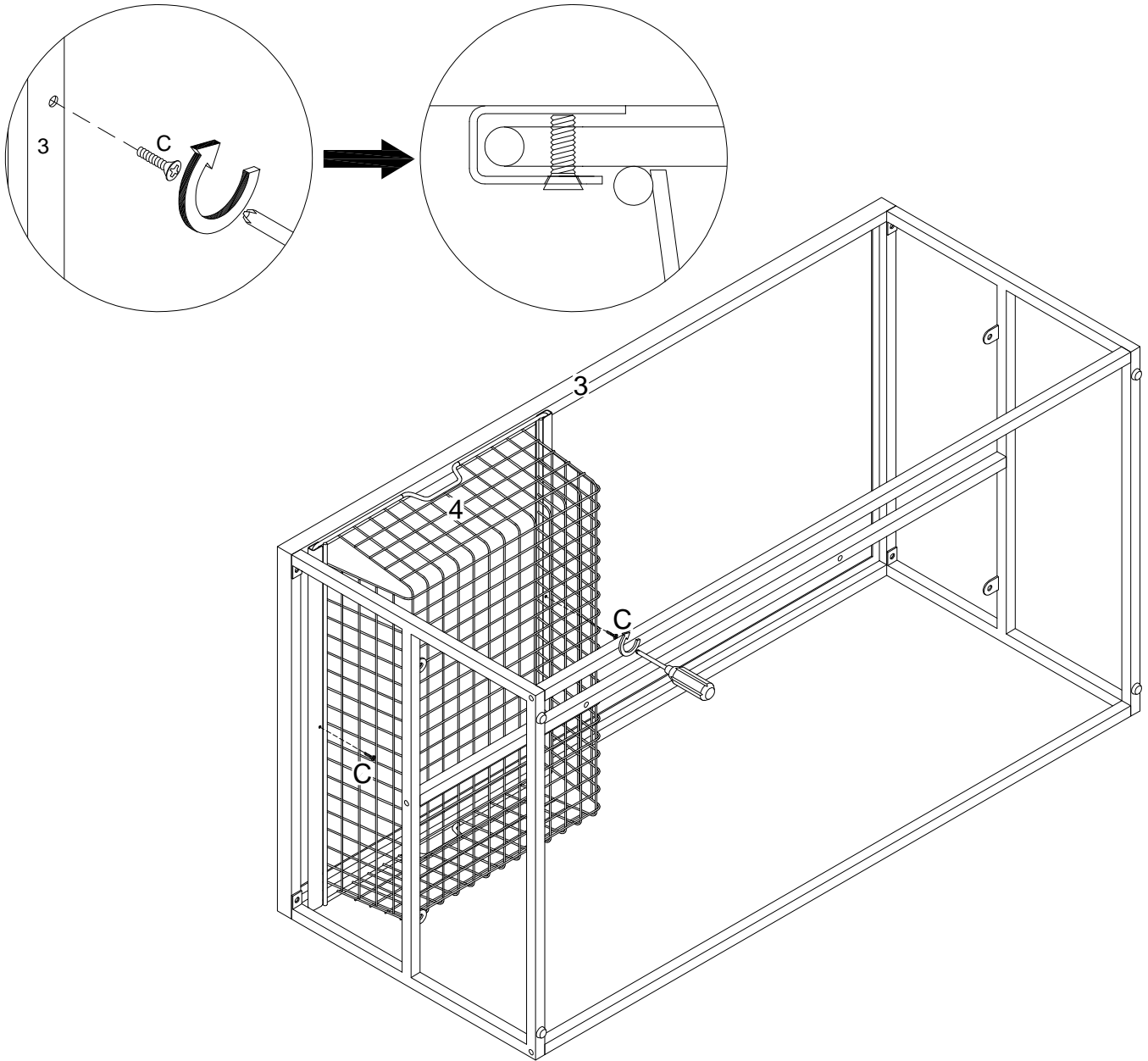

Using bolt (C) attach part (4) to part (3) with Philips head screwdriver as per diagram .

Step 5

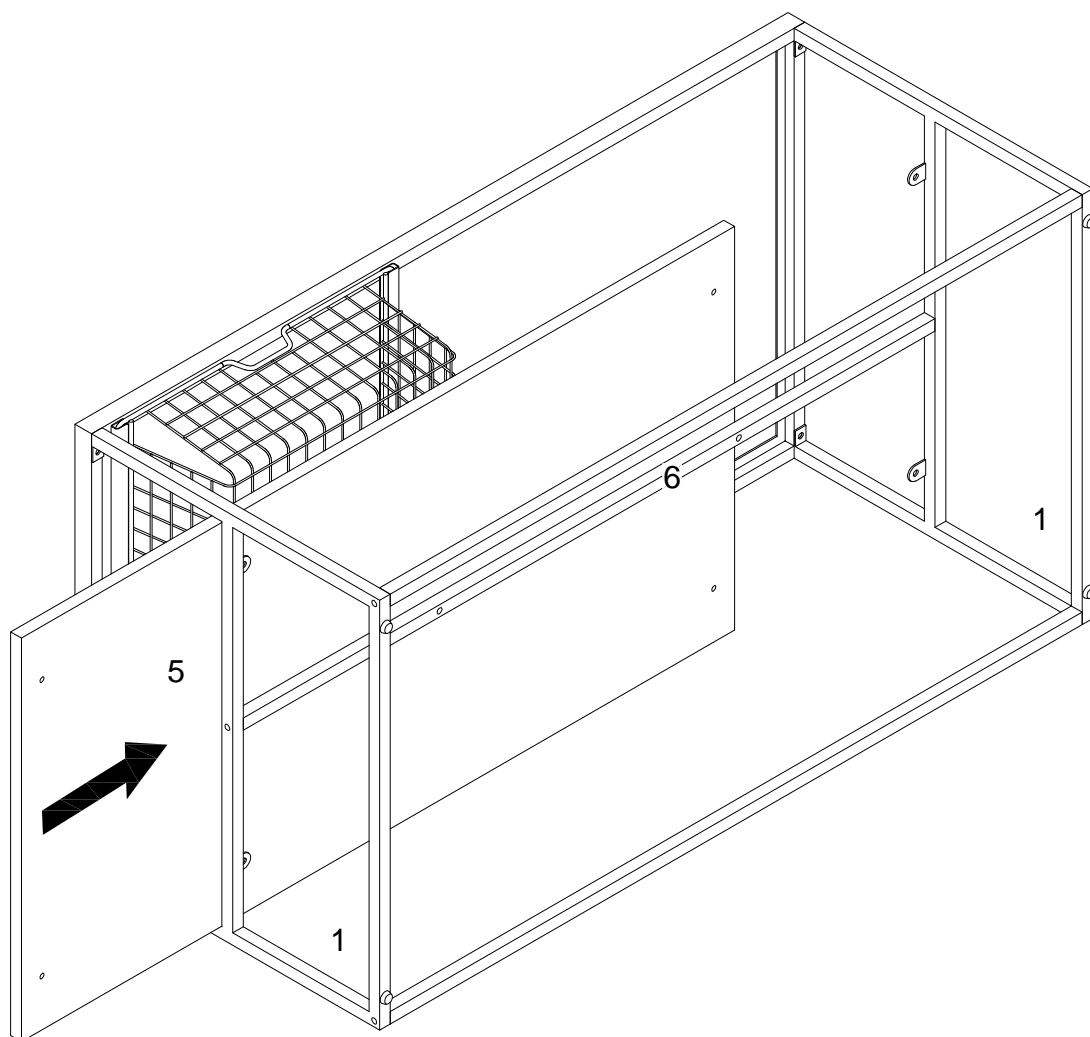

Put part (5) as per diagram.

Step 6

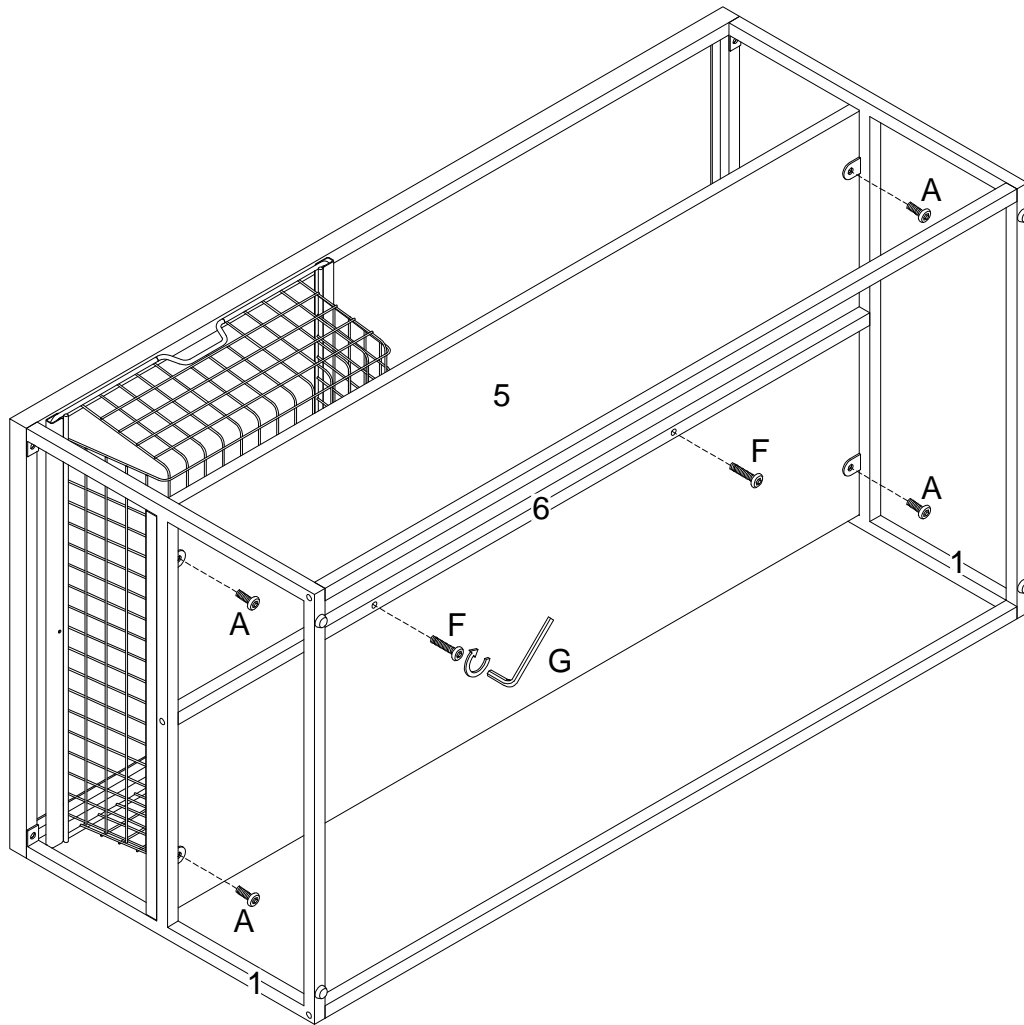

using bolt (A) secure part (1) to part (5),then using bolt (F) secure part (6) to part (5) with Hex key (G) as per diagram.

Step 7

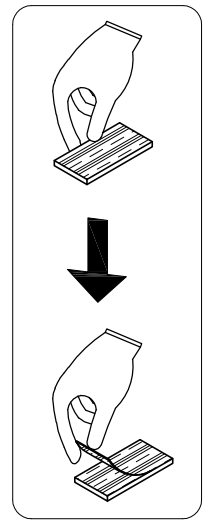
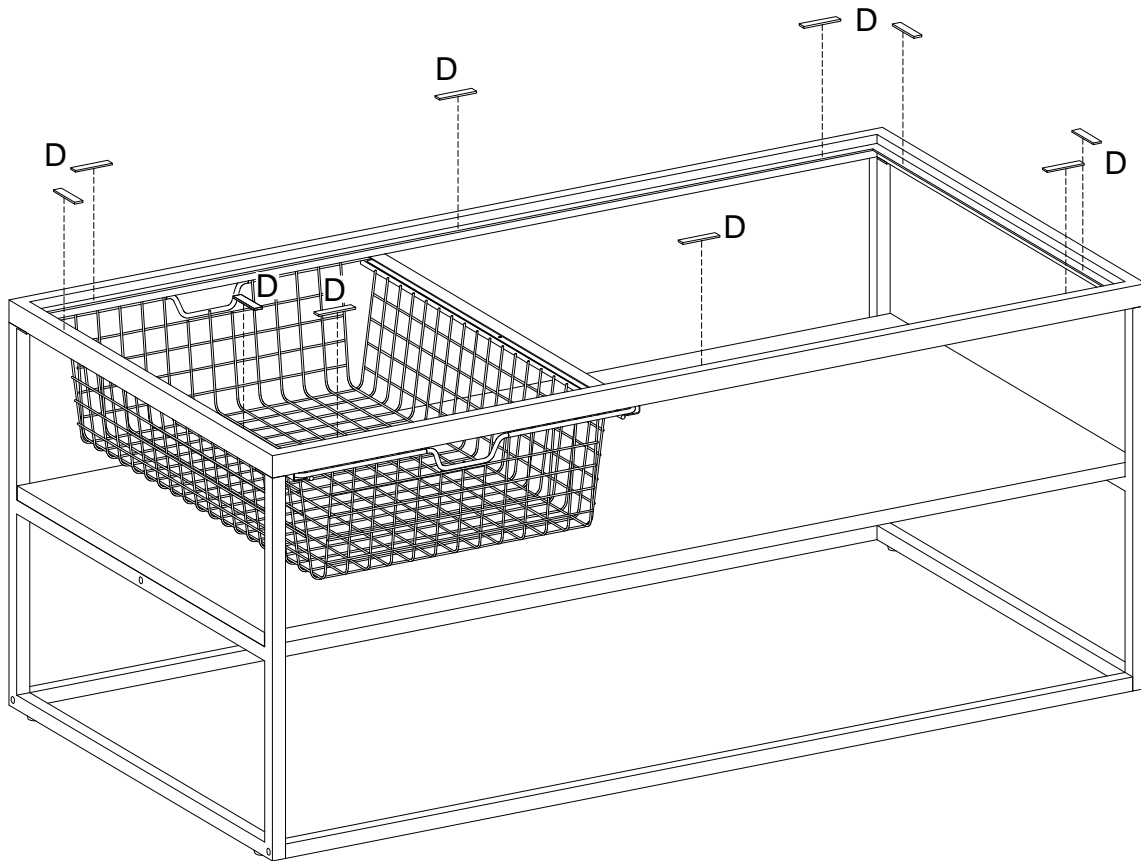

Tear off glass pad (D) and stick as per diagram.

Note : Fully tighten all the bolts .

Step 8

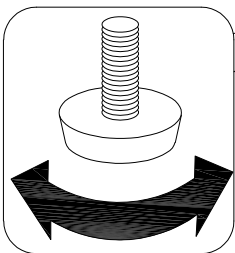
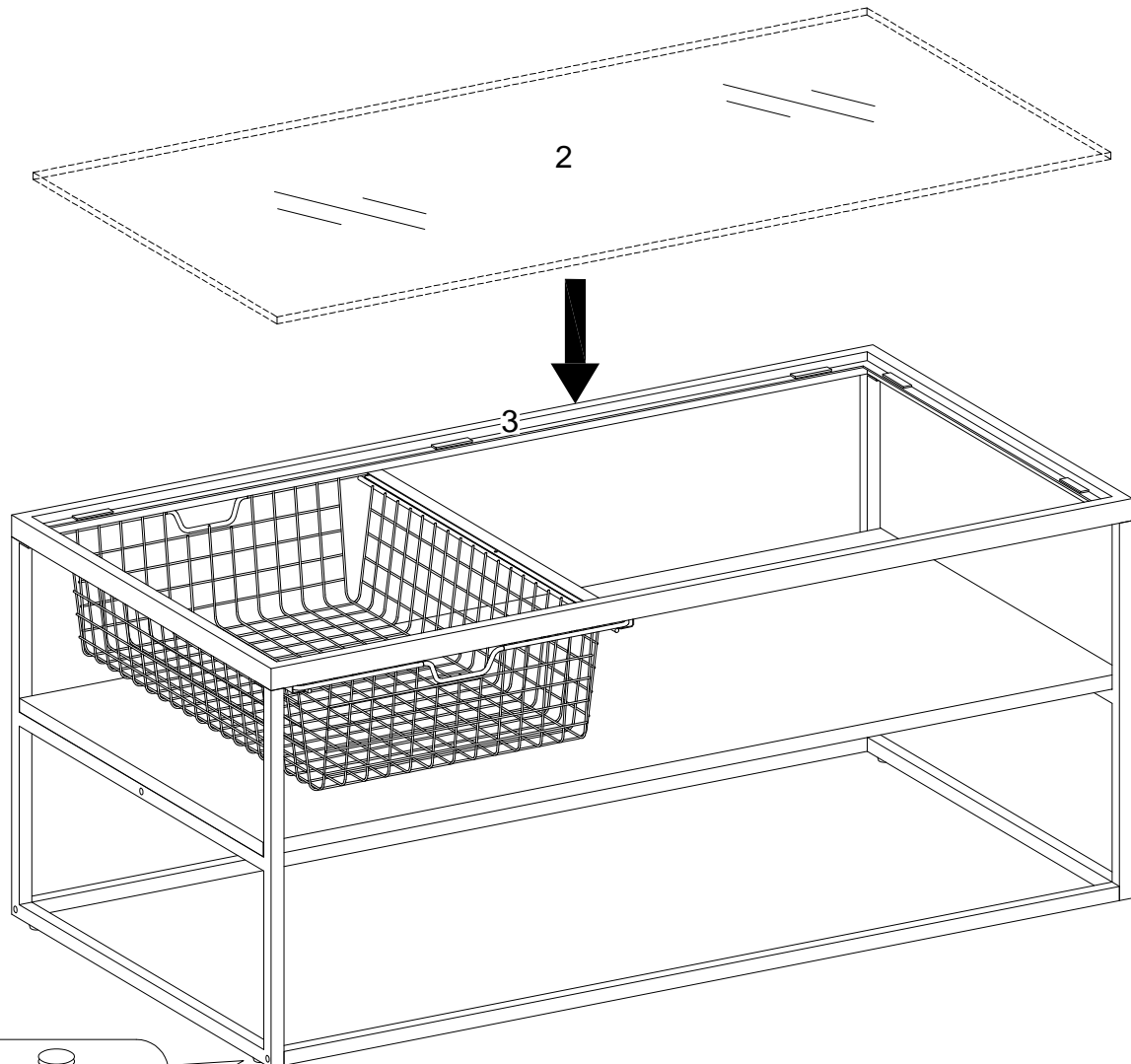

Put part (2) to part (3) carefully as per diagram.

Position the assembled unit at the desired location ,if necessary adjust the floor leveler at the bottom of the legs to level the unit .

Step 9

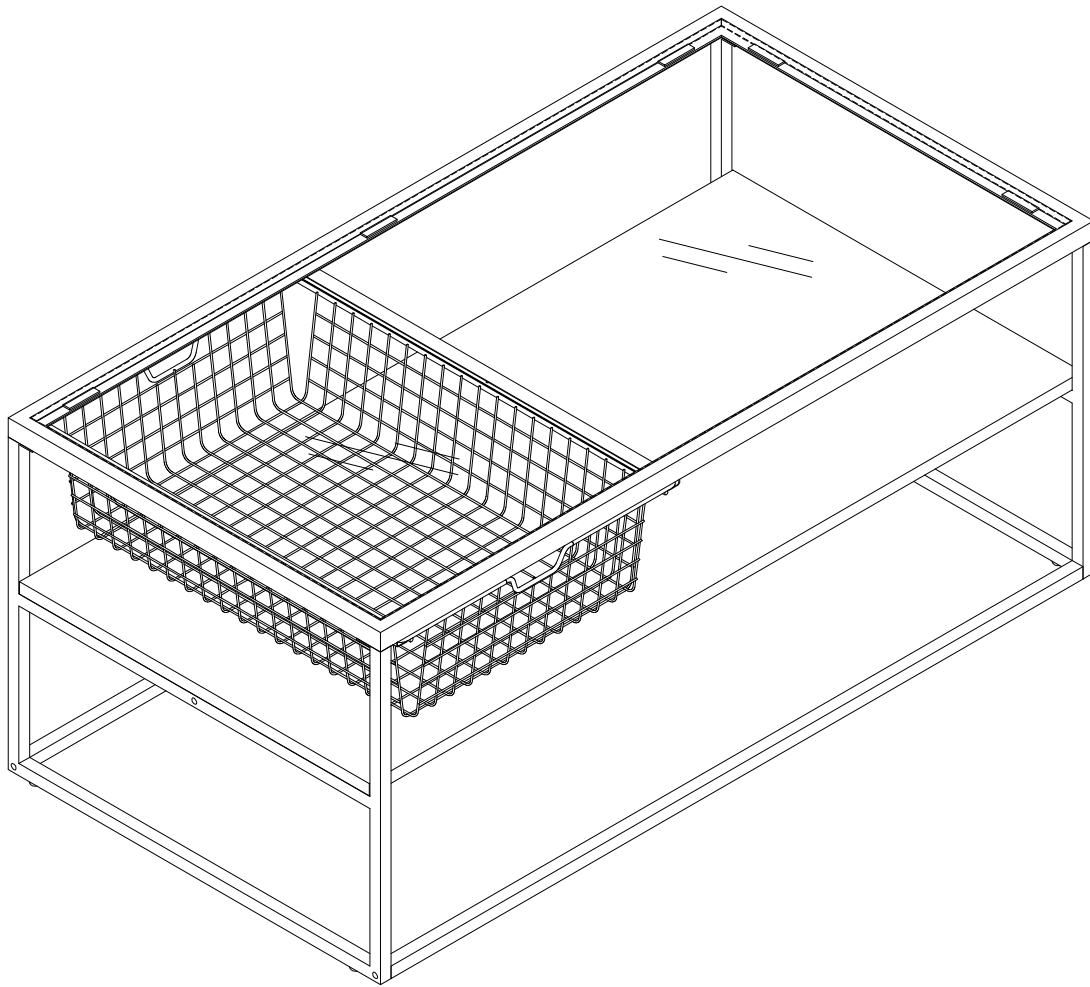

Final Assembly