









Assembly Instructions

Caution : You must read this before you proceed

Care & Maintenance

- ⊘  • Not for commercial use. For residential use only.
- ⊘  • Do not put hot items directly on furniture surface.
- ⊘  • Do not clean furniture with harsh cleansers or polish.
- ✓  • To obtain the longest lifespan of your outdoor products, minimizing exposure to direct sunlight is recommended.
- ⊘  • Children should not climb or jump on the furniture.
- ⊘  • Do not write on furniture without a padded barrier to protect the surface.
- ✓  • To obtain the longest lifespan of your outdoor products, avoid extended and lengthy exposure to rain, snow, and direct sunshine. Whenever possible cover the product and /or place under patio or awnings.
- ⊘  • Stains may be removed with mild soap solution and damp cloth.



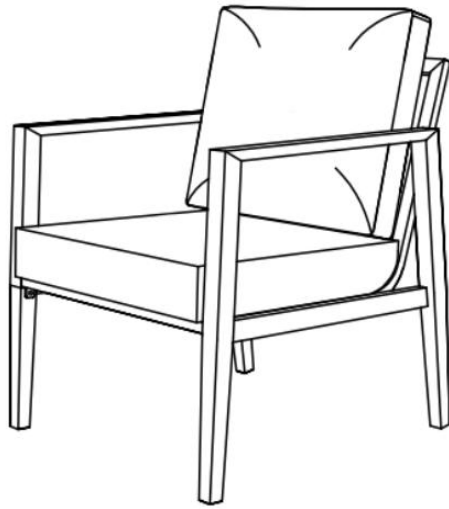

- ✓  • Dust and pick-up spills using a clean, non-colored, lint-free cloth.

Please look in boxes for hardware packs and legs.
Sets often ship in multiple boxes and may arrive a day or two apart.

Chair

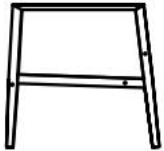
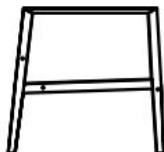

Parts List







Label	Picture	Description	QTY
A		Left Armrest/Leg	1
B		Right Armrest/Leg	1
C		Seat Frame	1
D		Seat Cushion	1
E		Back Cushion	1

Hardware

Label	Picture	Description	QTY
①		Allen Wrench	1

②		Bolt+Washer (M6*20MM)	7
---	--	--------------------------	---

Assembly Preparation

<p>Before Beginning Assembly:</p>	<div style="display: flex; justify-content: space-around; align-items: center;"> <div style="text-align: center;">  A </div> <div style="text-align: center;">  B </div> <div style="text-align: center;">  C </div> <div style="text-align: center;">  D </div> <div style="text-align: center;">  E </div> </div> <div style="display: flex; justify-content: center; align-items: center; margin-top: 20px;">  ①*1  ②*7 </div>				
---	--	--	--	--	--



- Read instructions, cover to cover-



- Have 2 adults on hand for assembly-



- Do not assemble on flooring or carpet-



- Assemble on a clean non-marring surface (packing foam)-



- Save all packaging until finished-

Assembly Steps

Overview

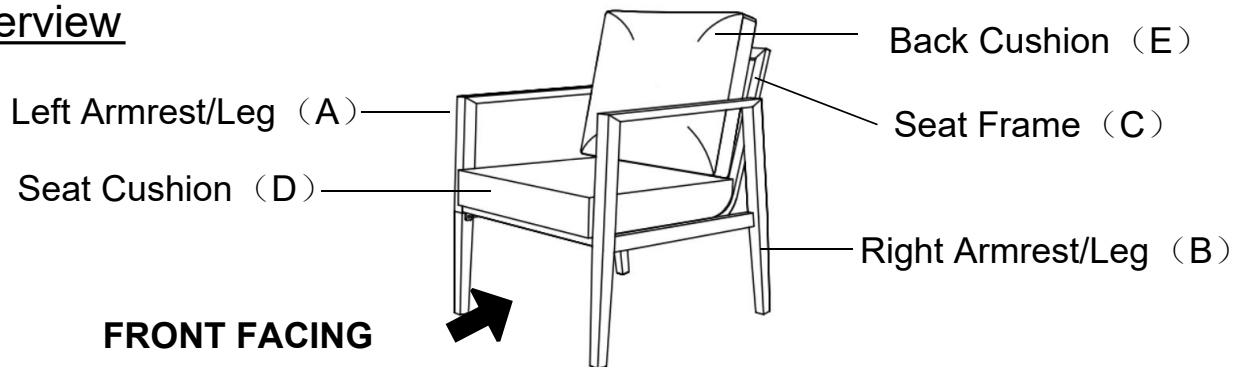

This Chair has multiple parts and may require up to 30 minutes to assemble. To give you an overview of the Chair parts, the above picture is to help you put the various parts into perspective. Please read through the instructions below to familiarise yourself with the parts and steps before assembly.

Step 1

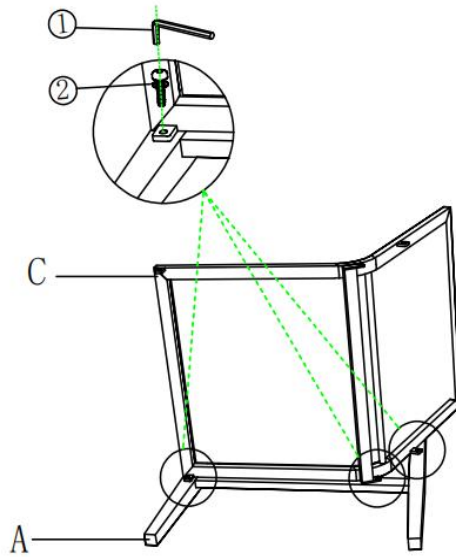

Unpack and place all parts on a clean, non-marring surface.

Use Bolt+Washer (M6*20MM)(②) and Allen wrench connect the Seat Frame(C) to the Left Armrest/Leg (A) .

Do not fully tighten the Bolts.

Step 2

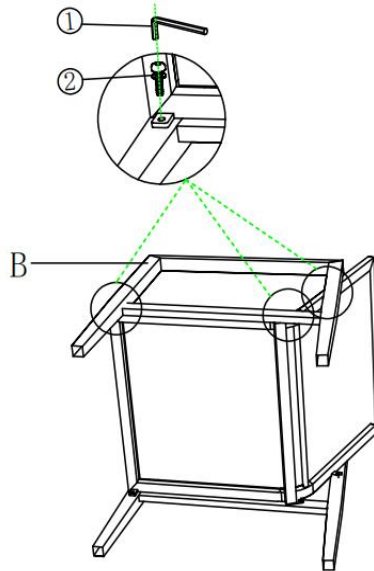

2.1) Use Bolt+Washer (M6*20MM)(②) and Allen wrench connect the Seat Frame(C) to the Right Armrest/Leg (B) as shown in the above picture.

2.2) Install the front and rear positions using the same method.

Do not fully tighten the Bolts.

Step 3

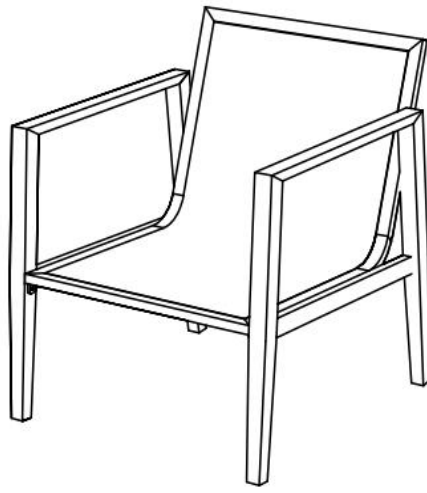

Place the Chair on a **LEVEL SURFACE**.

Inspect it and make sure all parts are adequately connected.

Gently and carefully sit onto the Chair.

This will help to align all parts at all joints.

Then get off the Chair, and in a sequential manner, proceed to tighten all Bolts.

When tightening the Bolts, tighten sequentially.

DO NOT tighten any Bolt fully and then move on to the next one.

This may cause the frame to warp.

If there are any wobbles after tightening, loosen the Bolts and execute this same process.

Note: This step is done best with the assistance of a second adult.

Step 4

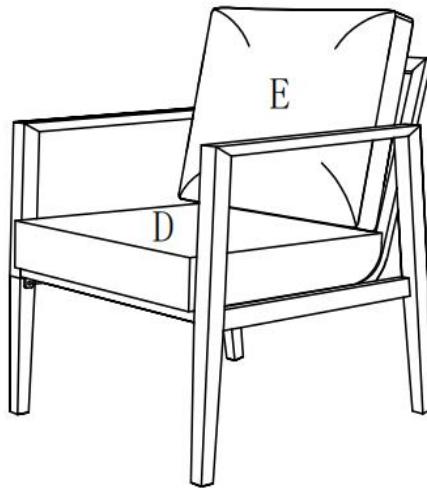

Place the seat cushion (D) on the seat.

Place the back cushion (E) in front of the back frame.

Your Chair is ready for use.

This Chair can only be used on a flat and level surface.