

WARNING



Children have died from furniture tipover. To reduce the risk of furniture tipover:

- ALWAYS install tipover restraint provided.
- NEVER put a TV on this product.
- NEVER allow children to stand, climb or hang on drawers, doors, or shelves.
- NEVER open more than one drawer at a time.
- Place heaviest items in the lowest drawers.
- Do not defeat or remove the drawer interlock system.

This is a permanent label.

Do not remove!

ATTENTION



Des enfants sont morts du basculement des meubles. Pour réduire le risque de basculement des meubles:

- TOUJOURS installer la retenue de basculement fournie.
- NE JAMAIS mettre de téléviseur sur ce produit.
- NE JAMAIS permettre aux enfants de se tenir debout, de grimper ou de s'accrocher à des tiroirs, des portes ou des étagères.
- N'ouvrez JAMAIS plus d'un tiroir à la fois.
- Placez les objets les plus lourds dans les tiroirs les plus bas.
- Ne désactivez pas et ne retirez pas le système de verrouillage du tiroir.

Ceci est une étiquette permanente.

Ne pas enlever!

WARNING



Kinder sind an einem Möbelkipp gestorben. So verringern Sie das Risiko eines Umkippen von Möbeln:















- Installieren Sie IMMER die mitgelieferte Kipprückhaltevorrichtung.
- Stellen Sie NIEMALS einen Fernseher an dieses Produkt.
- Lassen Sie Kinder NIEMALS an Schubladen, Türen oder Regalen stehen klettern oder hängen.
- Öffnen Sie NIEMALS mehr als eine Schublade gleichzeitig.
- Legen Sie schwerste Gegenstände in die untersten Schubladen.
- Besiegen oder entfernen Sie das Schubladenverriegelungssystem nicht.

Dies ist ein dauerhaftes Etikett.



Nicht entfernen!

PRODUCT ASSEMBLY

Hardware List

A	 6*30mm	20 pcs	F		1 pc	K		1 pc
B	 6*35mm	28 pcs	G		8 pcs	L		1 pc
C		28 pcs	H		16 pcs	M		2 pcs
D		16 pcs	I		4 pcs	N		8 PCS
E		1 pcs	J		15 pcs			

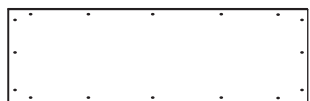
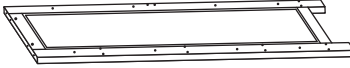
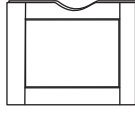
Parts List

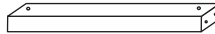
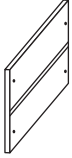
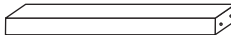
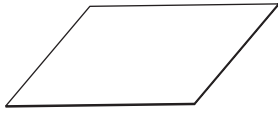
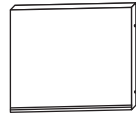
1		1 pc	7		1 pc
2		1 pc	8		4 pcs
3		1 pc	9		4 pcs
4		4 pc	10		4 pcs
5		2 pcs	11		4 pcs
6		4 pcs			

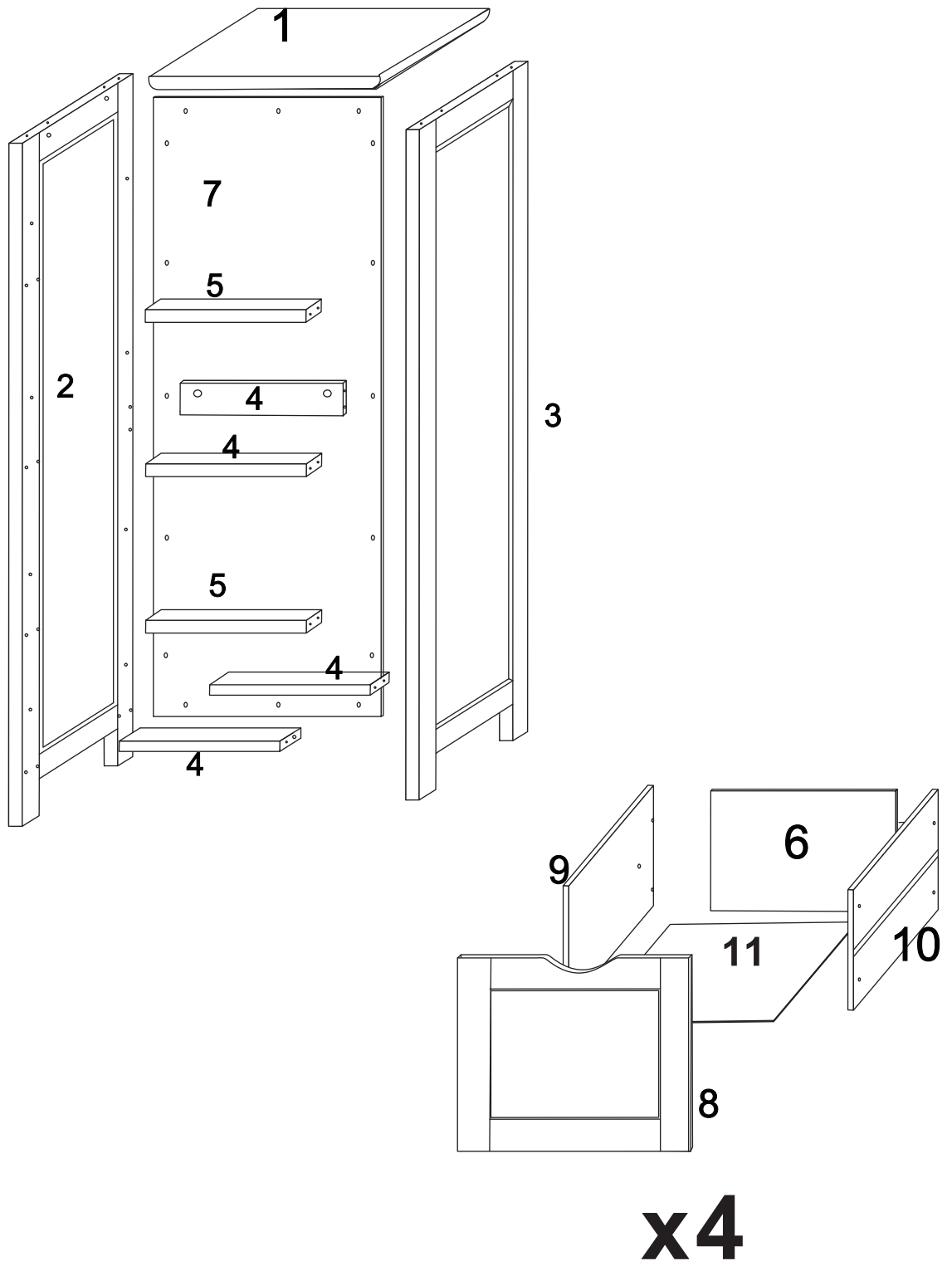

PRODUCT ASSEMBLY

Part List Assembly Overview





PRODUCT ASSEMBLY

Step 1

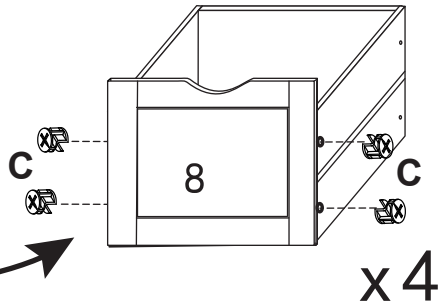
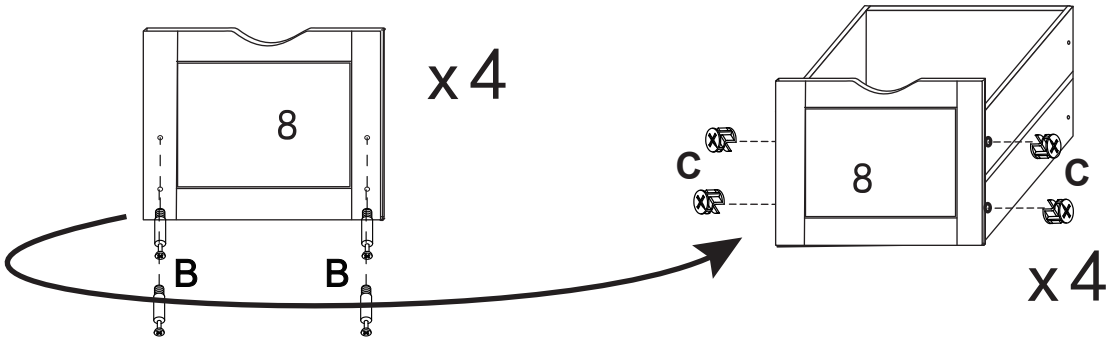
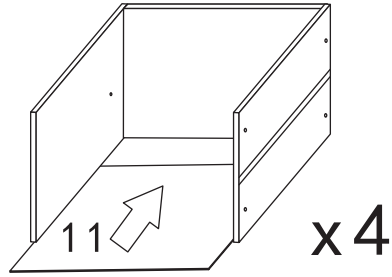
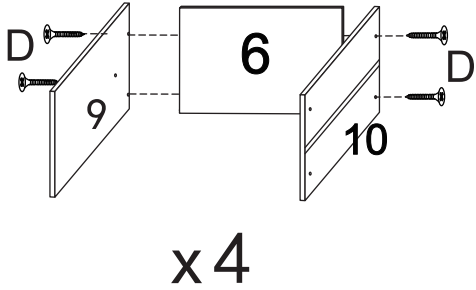
D		16 pcs
B		16 pcs
C		16 pcs



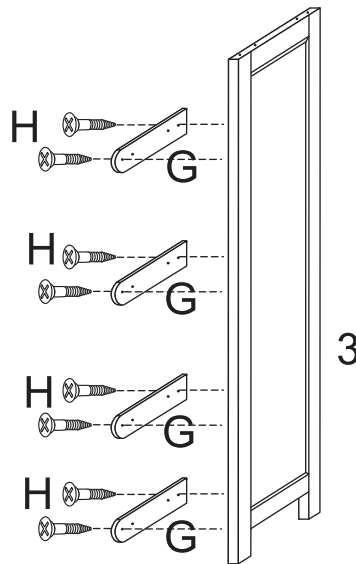
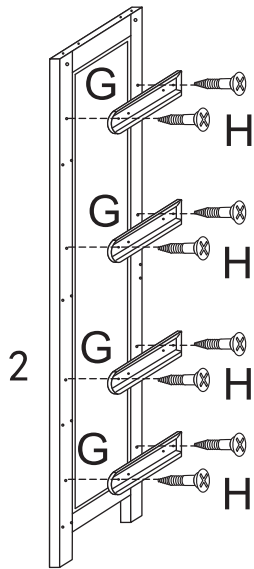

Step 2

G		8 pcs
H		16 pcs





PRODUCT ASSEMBLY

Step 3

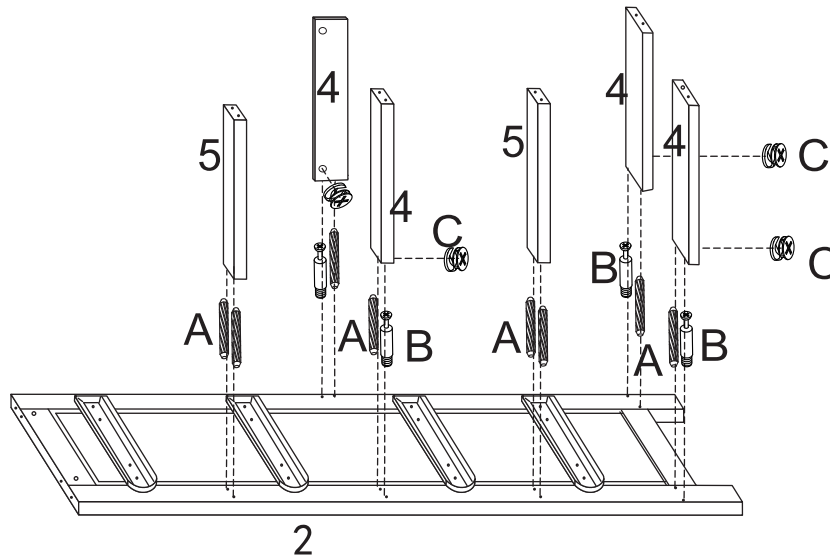
A		8 pcs
B		4 pcs
C		4 pcs



Step 4

A		8 pcs
B		4 pcs
C		4 pcs

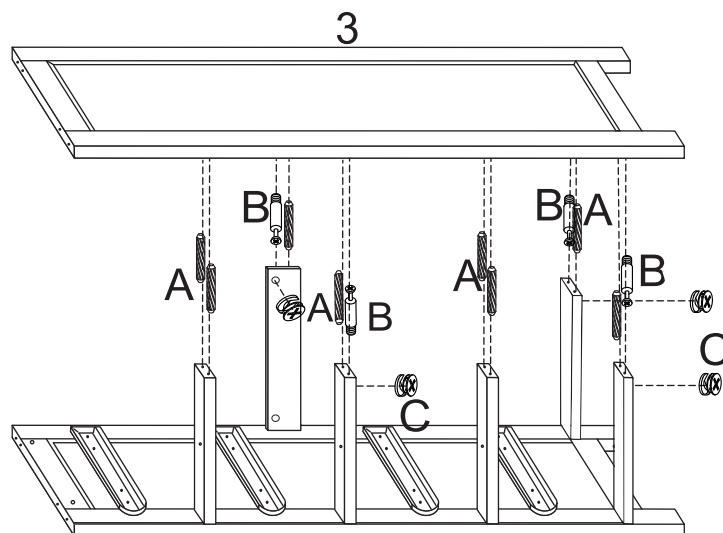

PRODUCT ASSEMBLY

Step 5

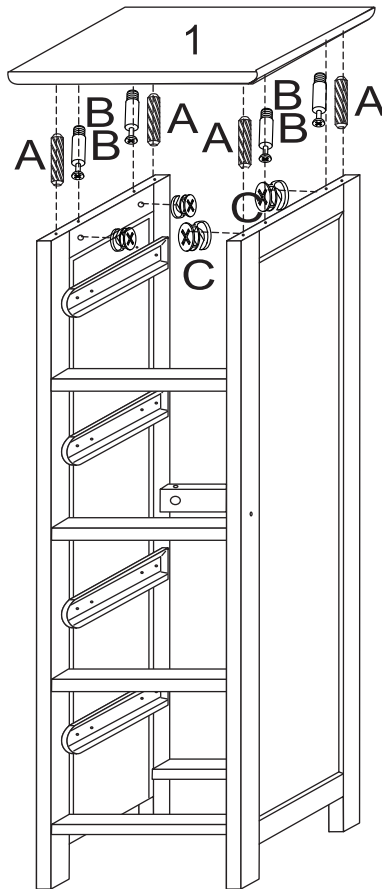

A		4 pcs
B		4 pcs
C		4 pcs

Step 6

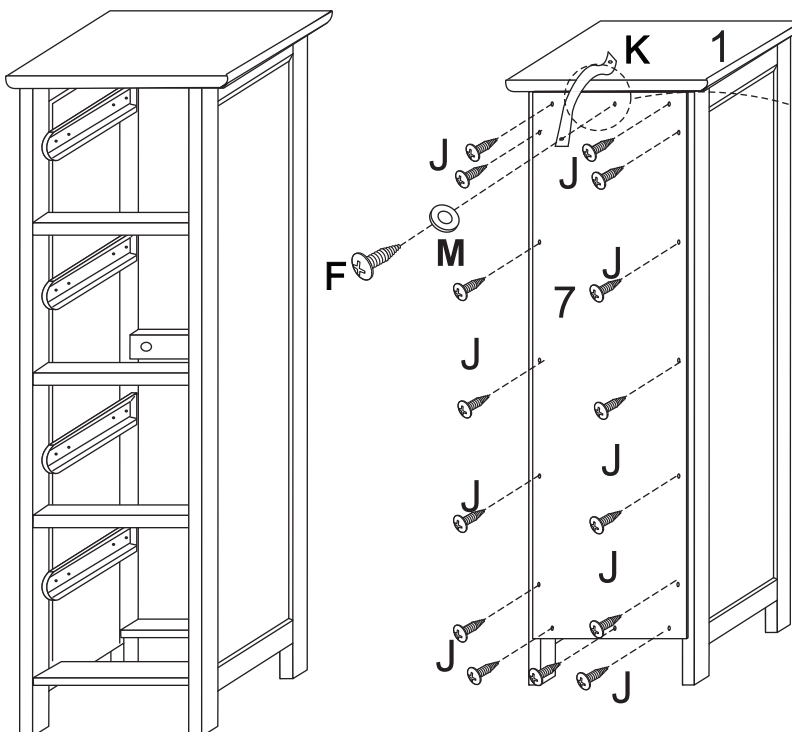

J		15 pcs
F		1 pc
M		1 pcs
K		1 pcs

PRODUCT ASSEMBLY

Step 7

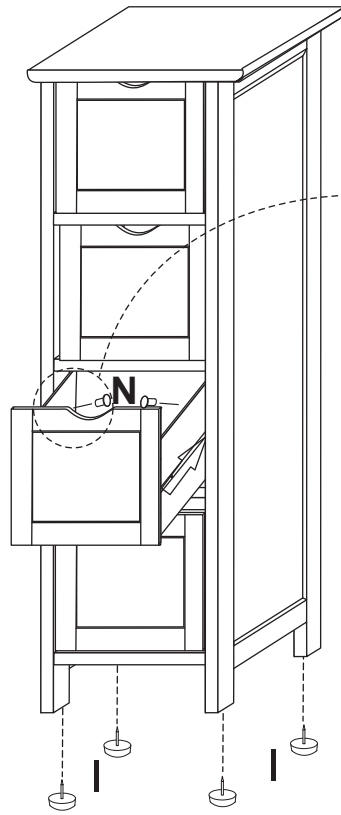

I		4 pcs
N		8 PCS

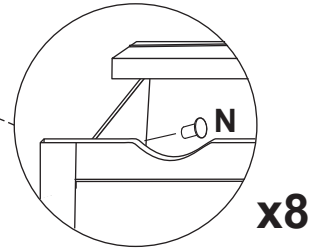

Step 8

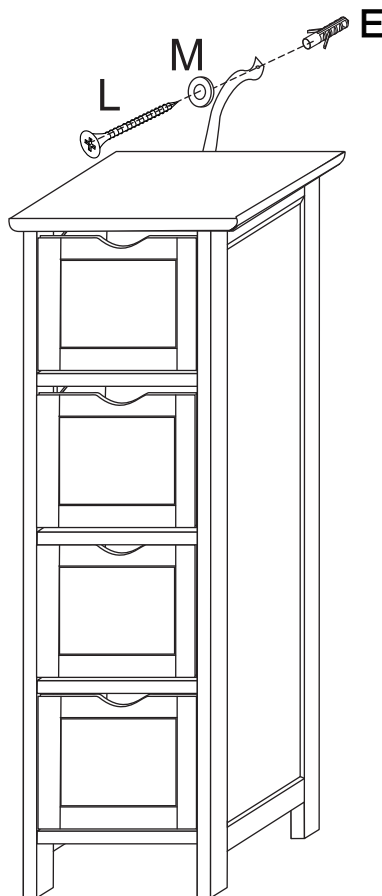
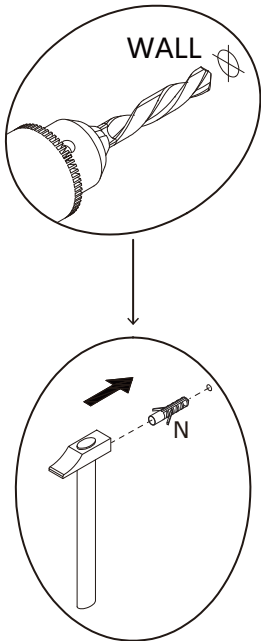

L		1 pc
M		1 pcs
E		1 pc