

ASSEMBLY INSTRUCTIONS

Important Safety Instructions:

- Please read all instructions before beginning assembly
- Please make sure receive all the parcels to start the assembly
- For your safety and convenience, assembly by two people is recommended
- Use the parts and hardware lists to identify and separate each of the components included
- Save all packing materials until assembly is completed to avoid the accidental discarding of smaller parts or hardware

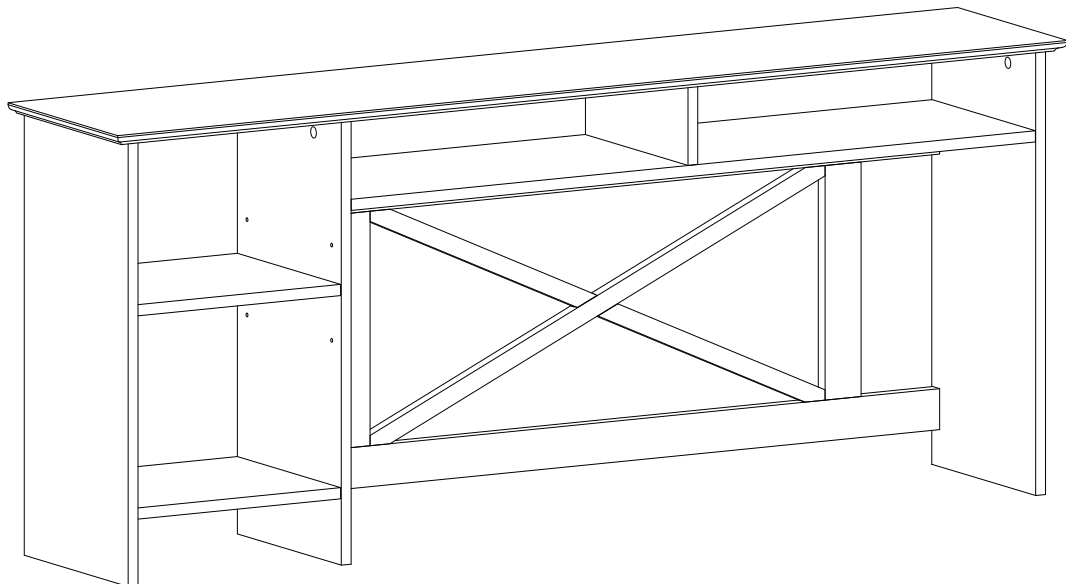



THANK YOU FOR PURCHASING



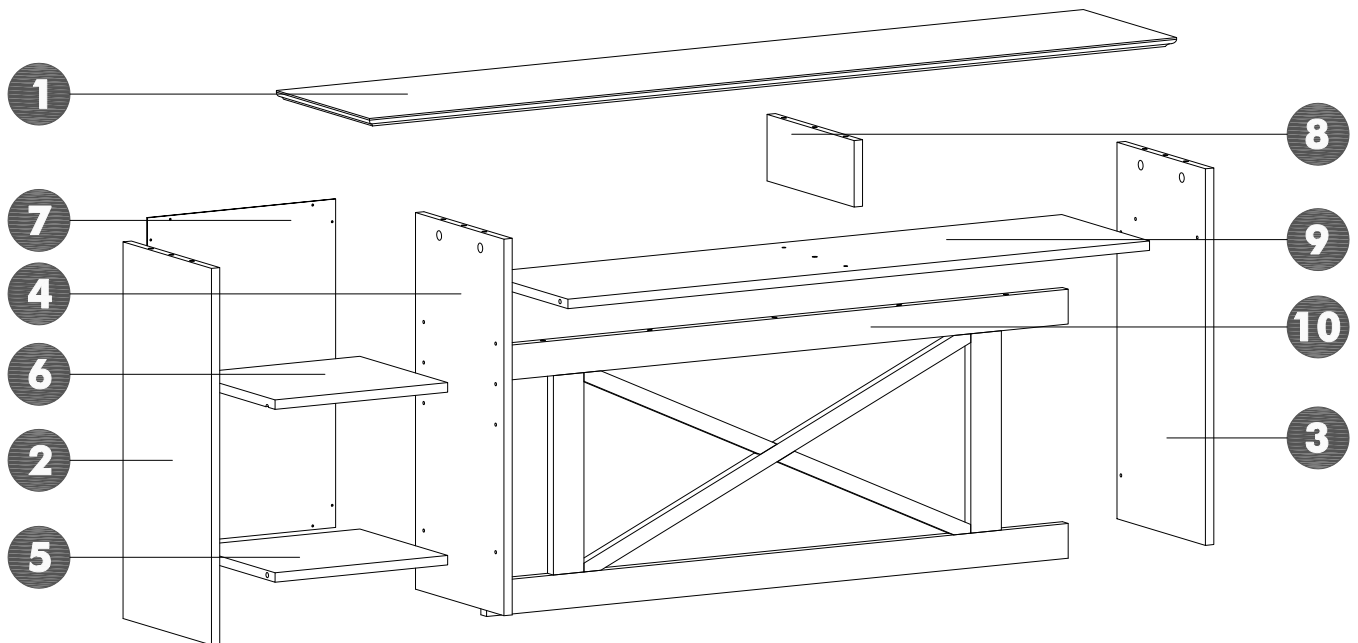

PARTS LIST

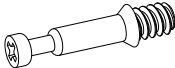
- ① X1 ② X1 ③ X1 ④ X1 ⑤ X1
 ⑥ X1 ⑦ X1 ⑧ X1 ⑨ X1 ⑩ X1

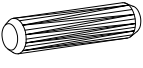
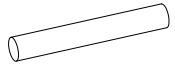
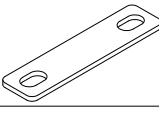
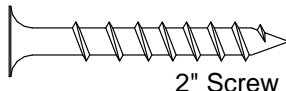

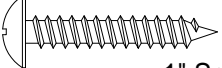
HARDWARE LIST

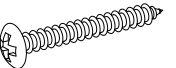
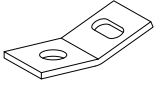
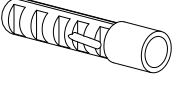
Name	Part	Qty.	Spare
A		23	1
B		23	1
C		7	1
D		4	
E		2	
F	 2" Screw	2	

Name	Part	Qty.	Spare
G	 1" Screw	4	1
H	 3/4" Nail	10	1
U1		2	
U3		2	
U4		1	
U5		1	

STEP 1

A x 15pcs 

C x 7pcs 

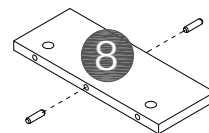
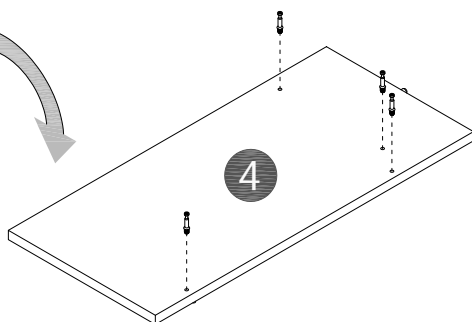
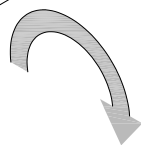
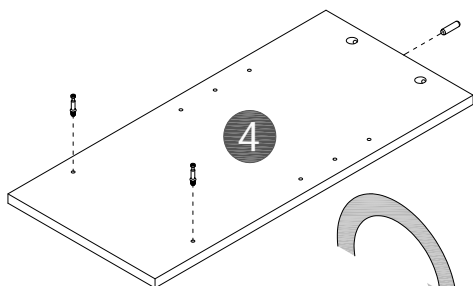
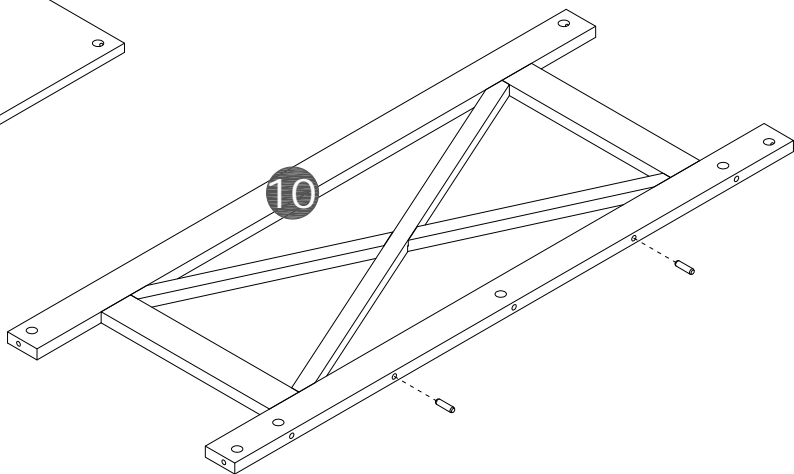
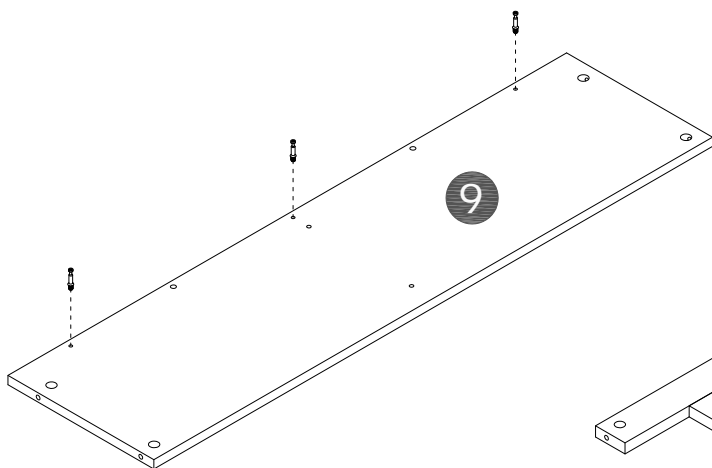
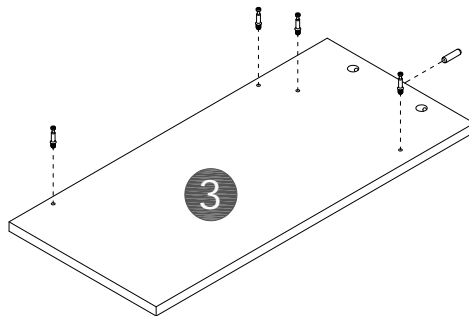
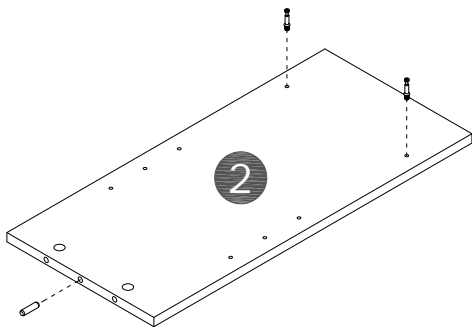
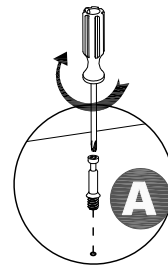
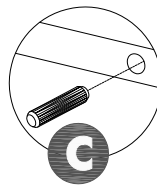

STEP 2

B x 3pcs

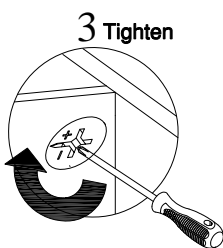
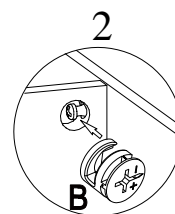
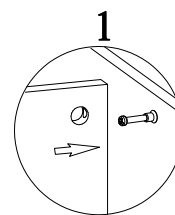
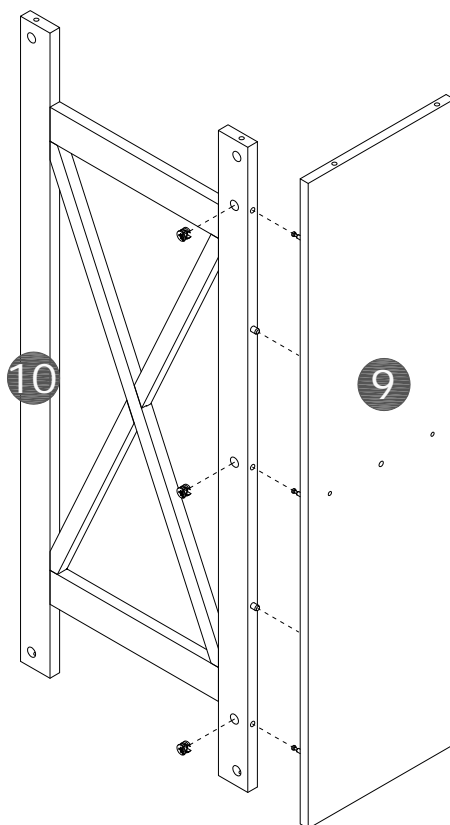

STEP 3

F x 2pcs

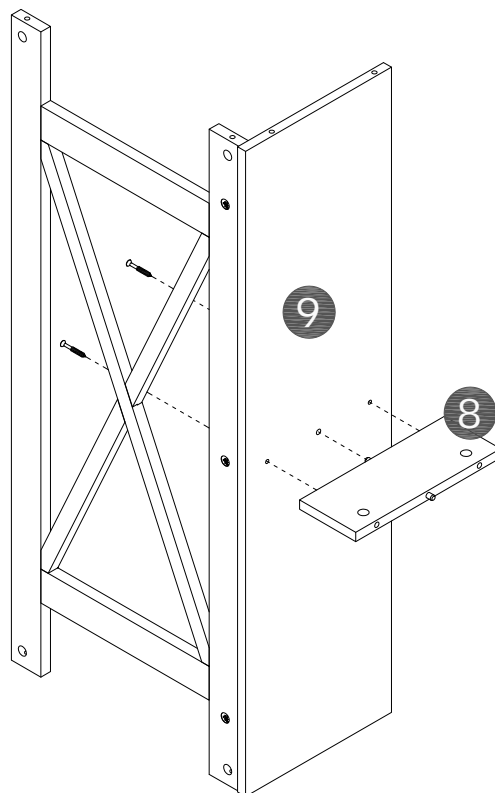
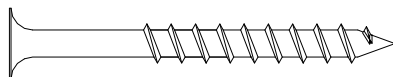

STEP 4

B x 4pcs

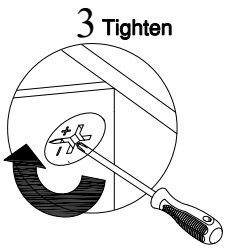
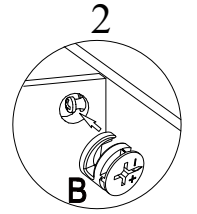
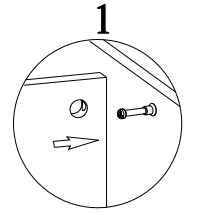
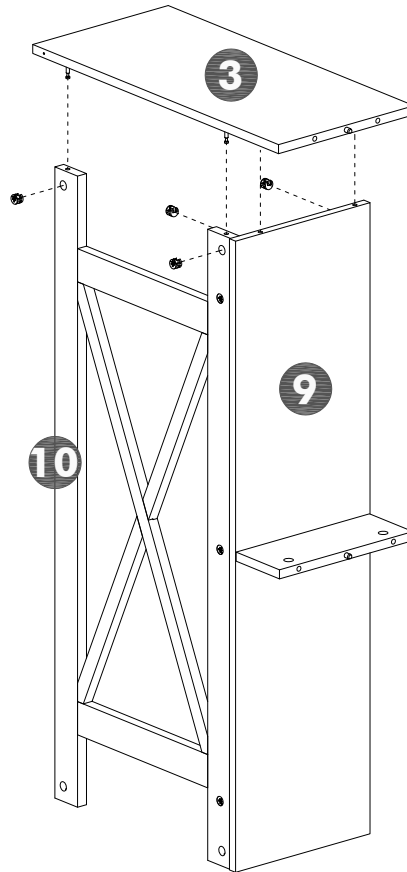

STEP 5

B x 4pcs

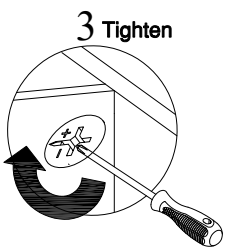
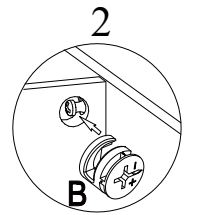
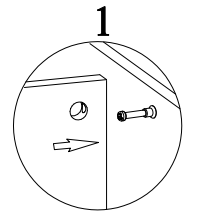
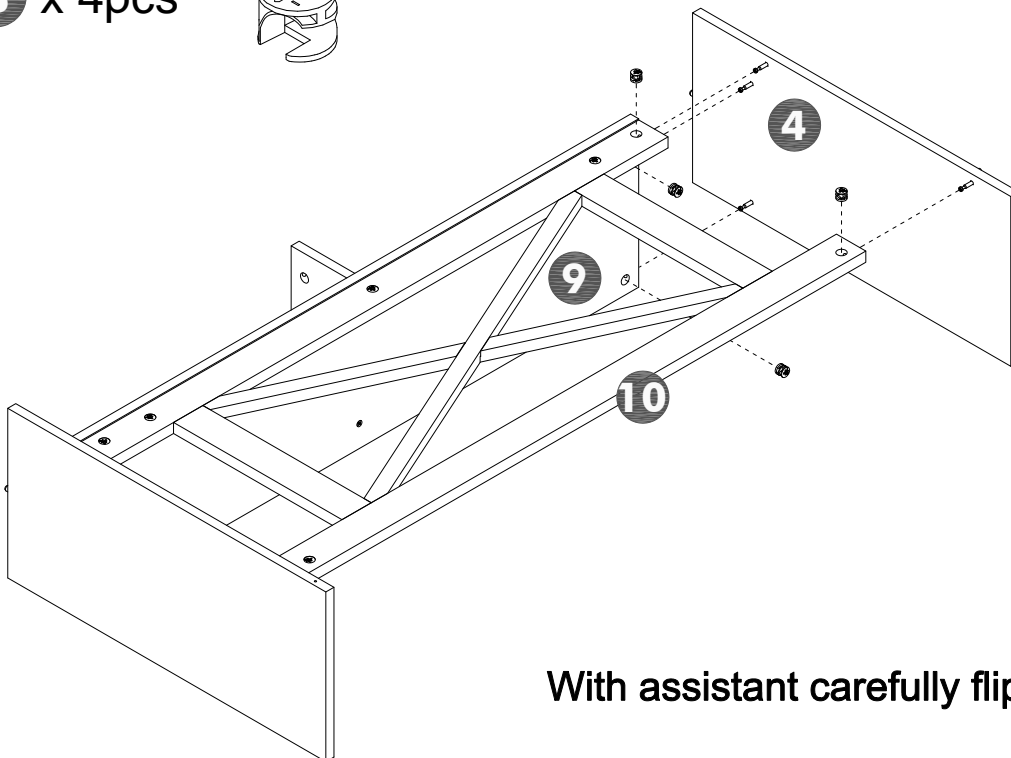

With assistant carefully flip unit over.

STEP 6

B x 4pcs

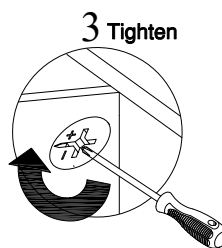
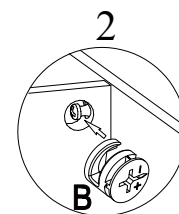
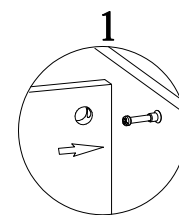
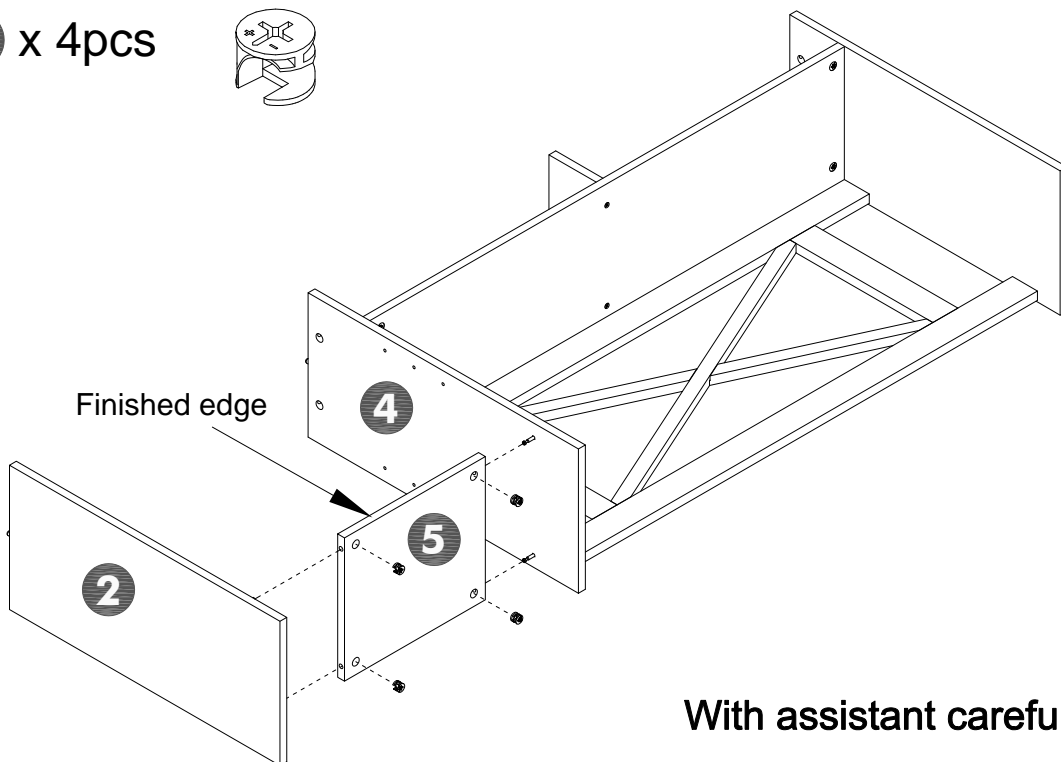

With assistant carefully flip unit over.

STEP 7

A x 8pcs

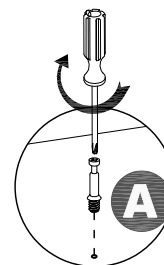
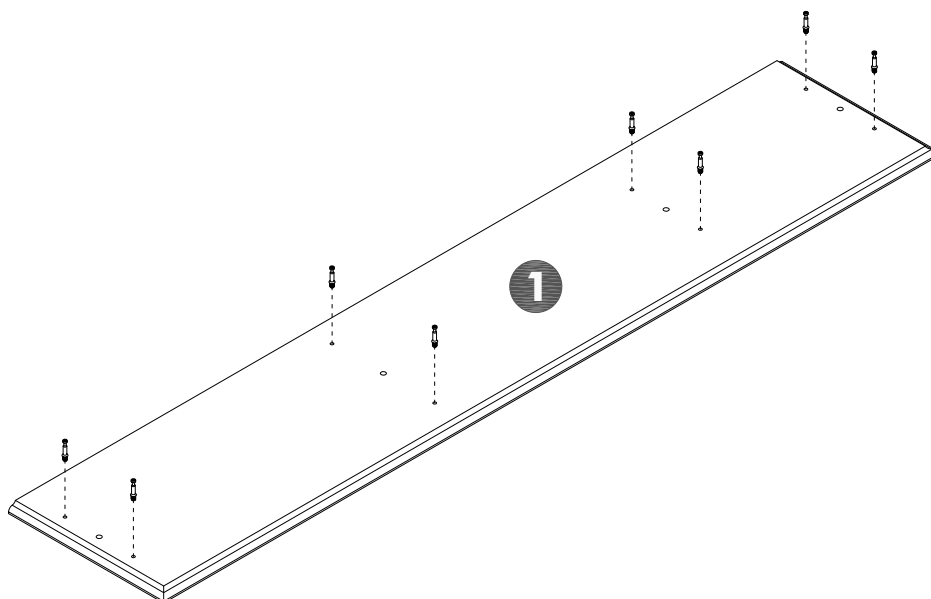
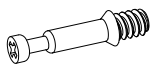

STEP 8

B x 8pcs

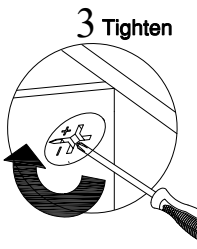
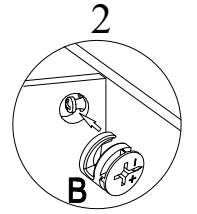
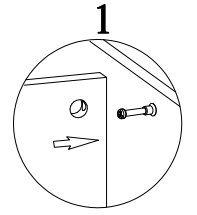
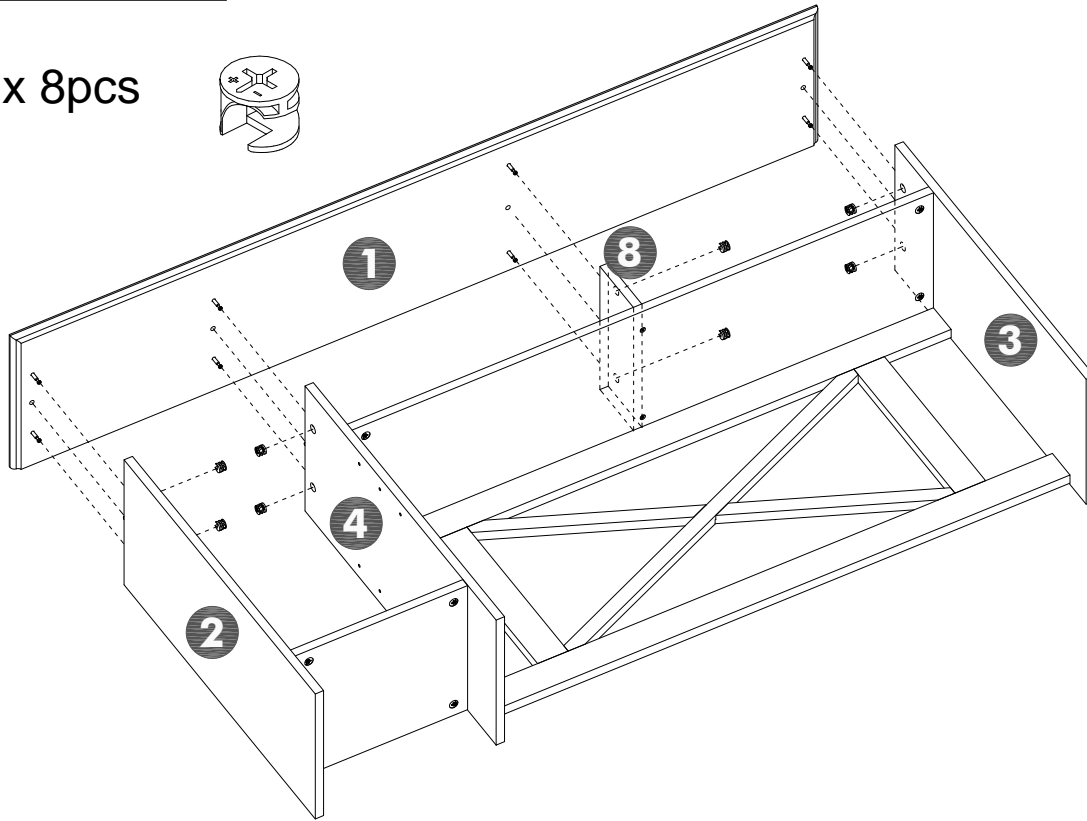

STEP 9

H x 10pcs

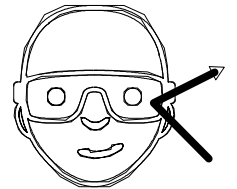

Safety glasses

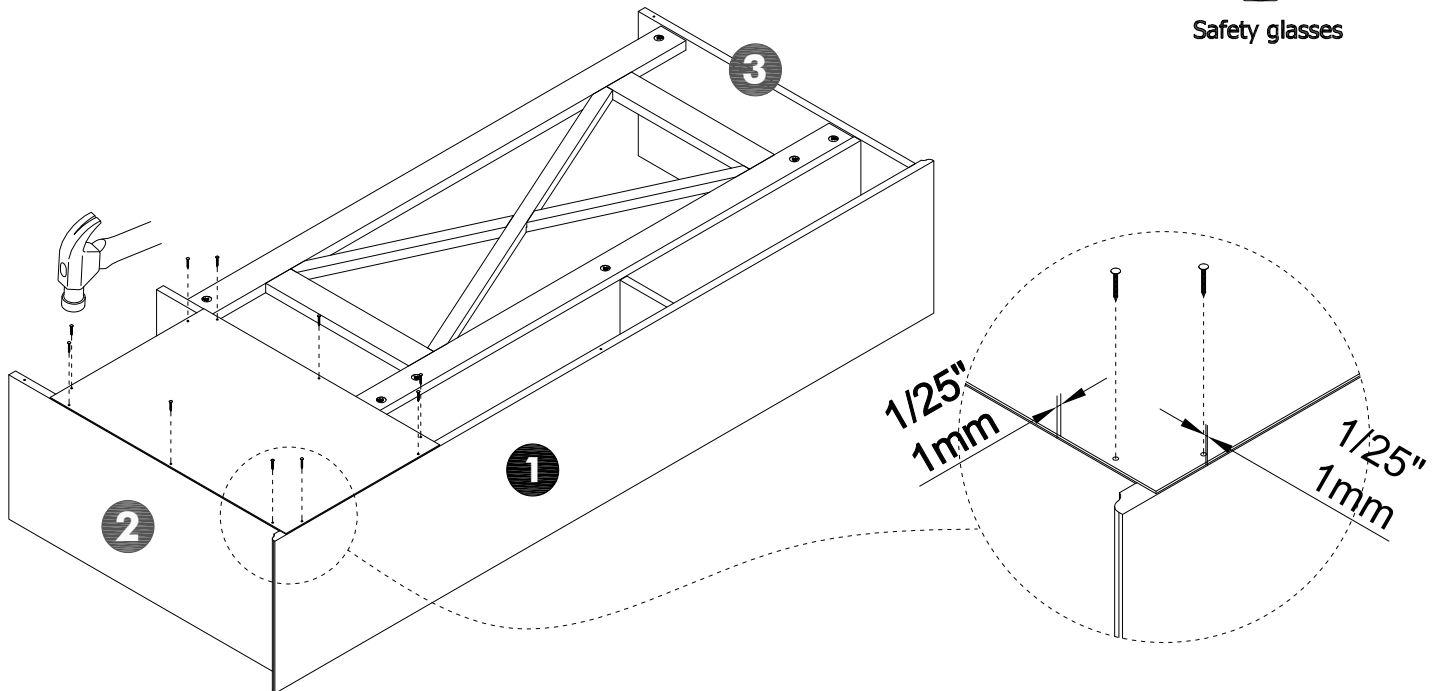

With assistant carefully flip unit over.

STEP 10

An assistant is required.

E x 2pcs

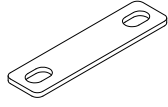

G x 2pcs

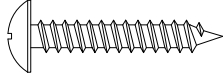

OF0101/OF0109

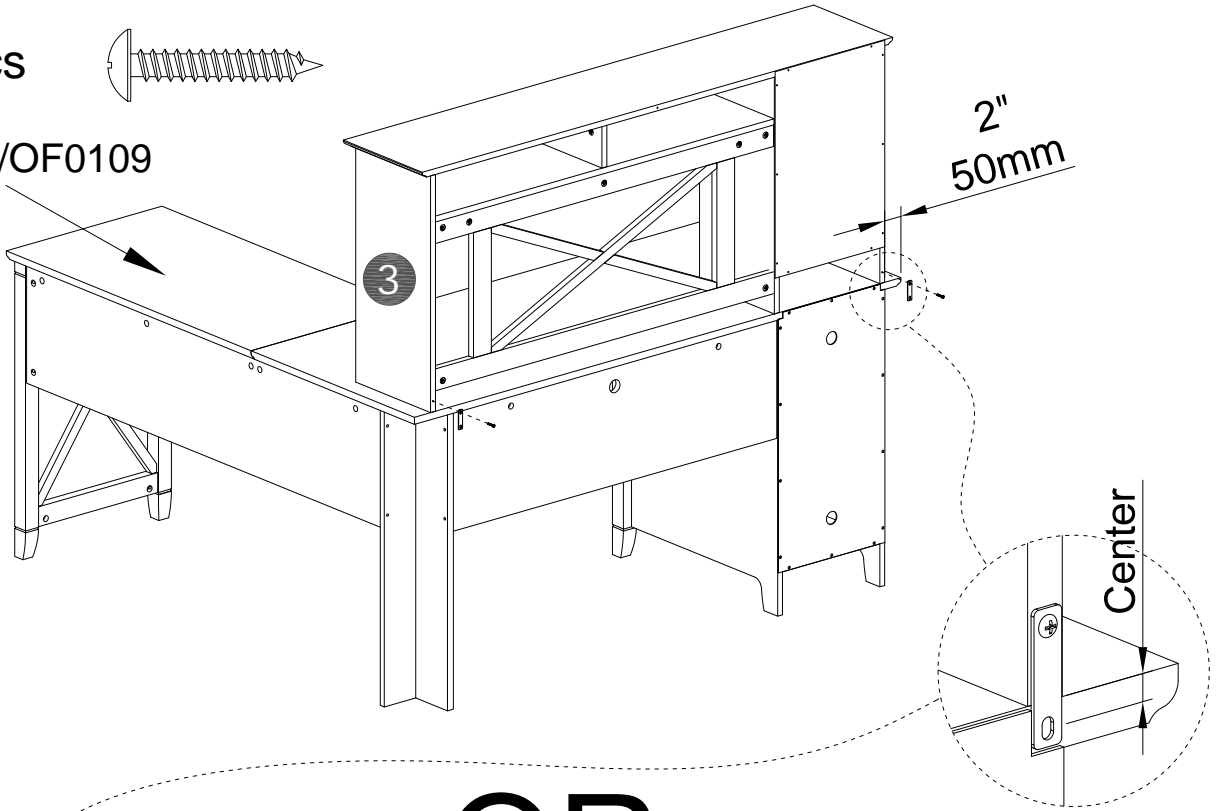

OR

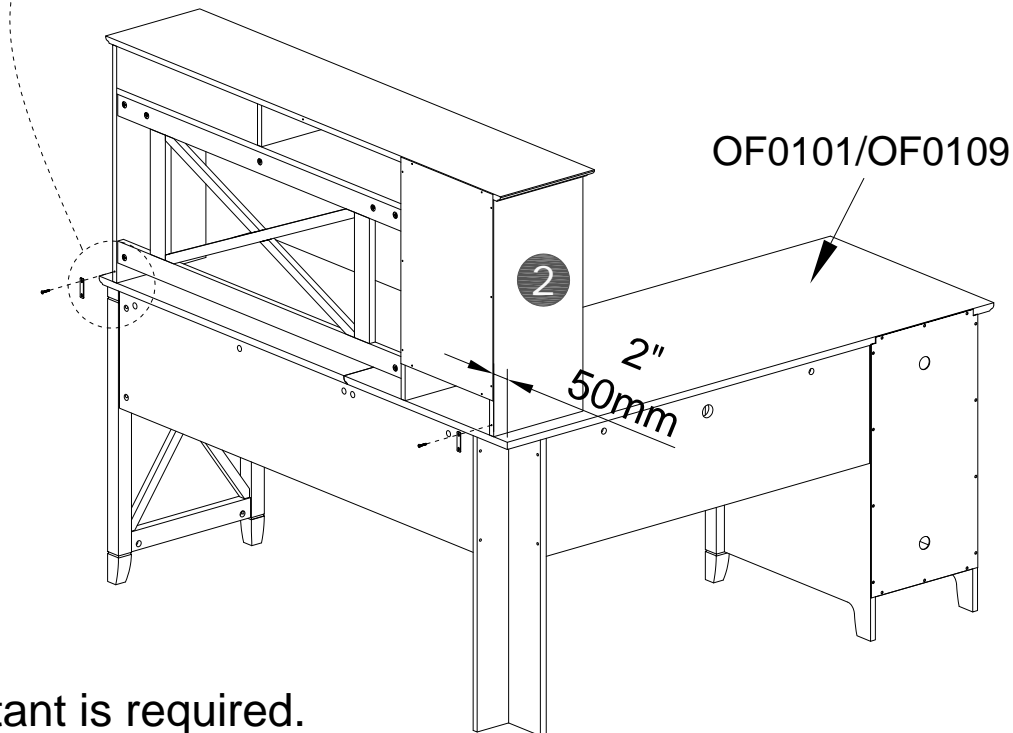

An assistant is required.

STEP 11

G x 2pcs

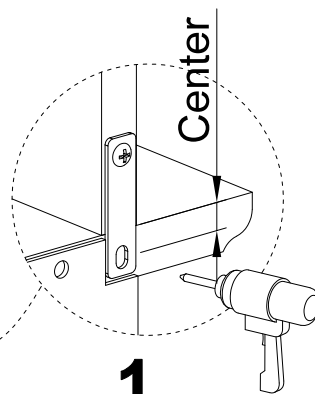
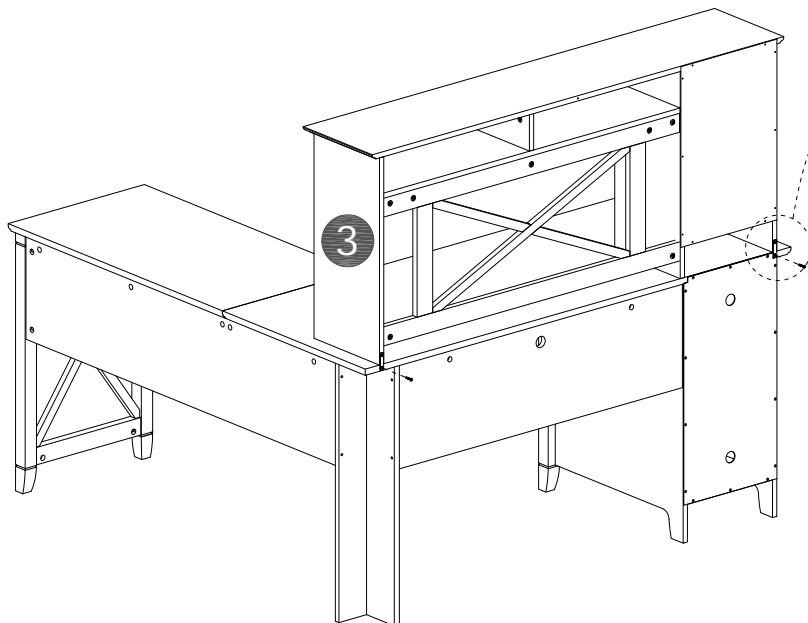
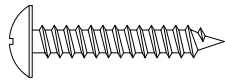

1

Use electric drill to lead 1/8 hole and drill 5/8 deep

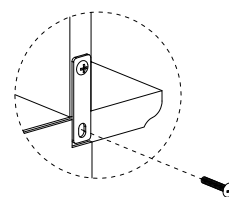

2

STEP 12

U₁ x1pc

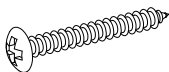

U₃ x1pc

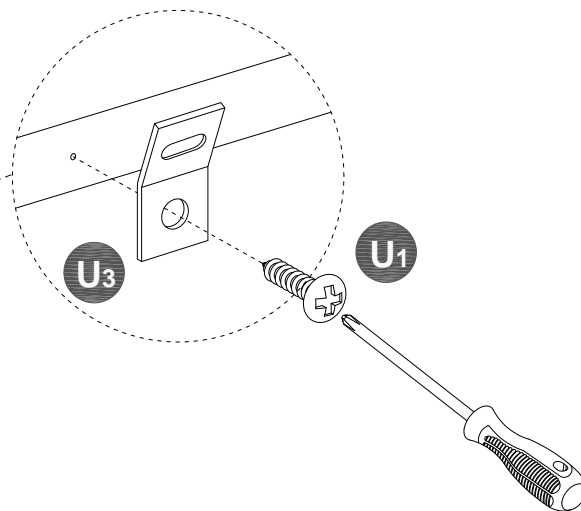
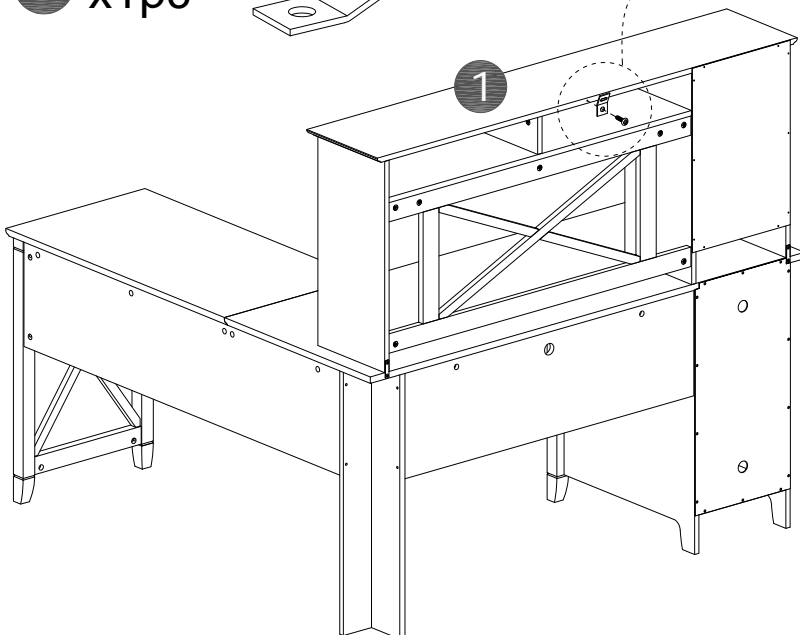
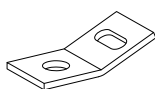

U₃

U₁

STEP 13

U₄ x 1pc

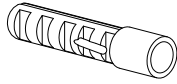

D x 4pcs

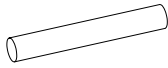

1. Place unit in desired location.
2. Mark stud location on the wall, 1" below top and side of unit.
3. Drill 5/16" hole 2" deep at marks on the wall.

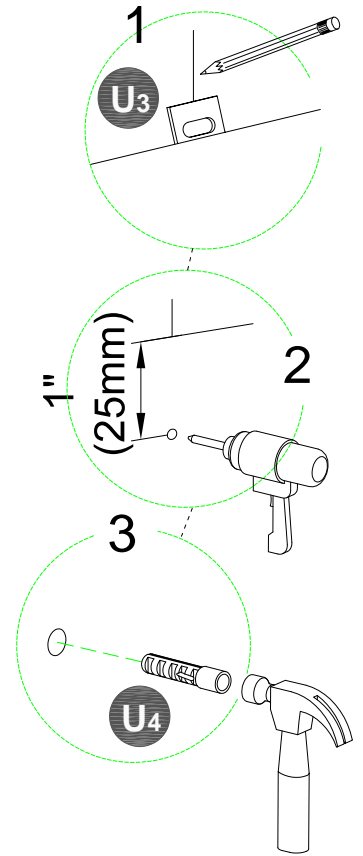
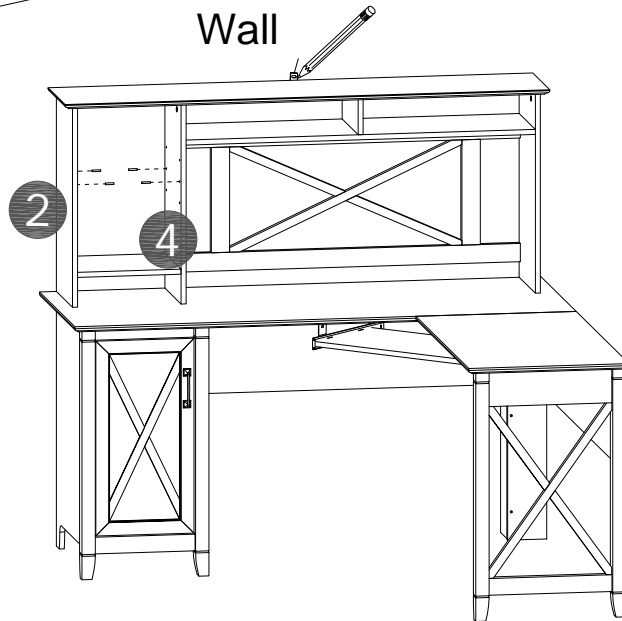

STEP 14

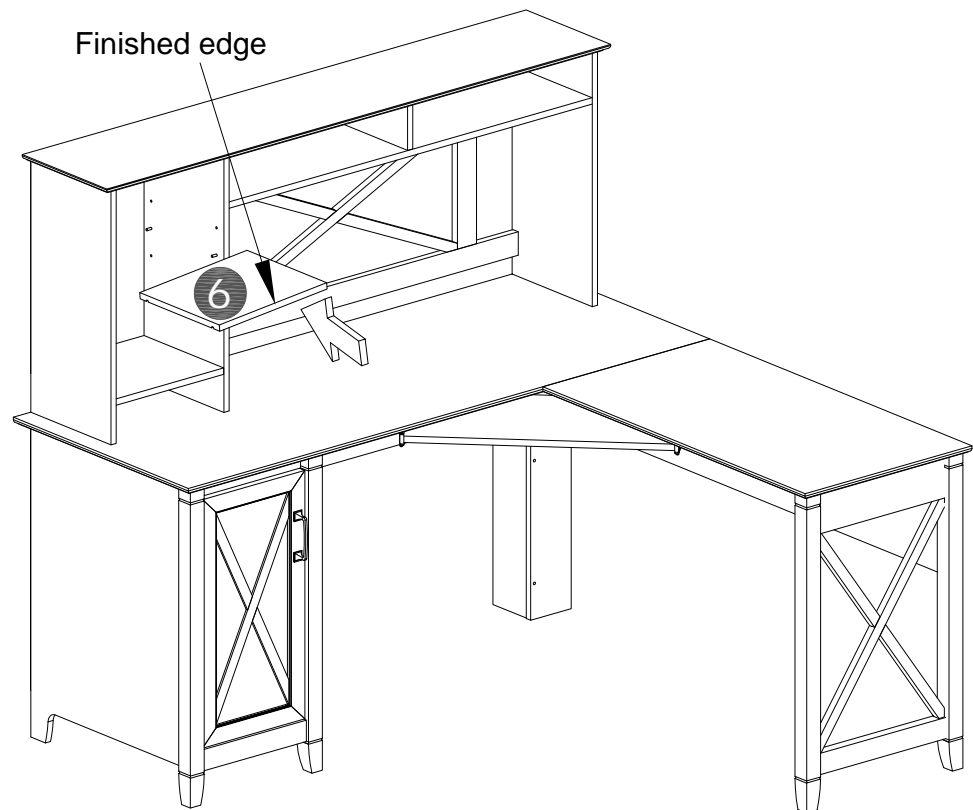

STEP 15

U₁ x1pc

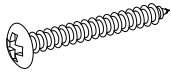

U₅ x1pc



U₃ x1pc

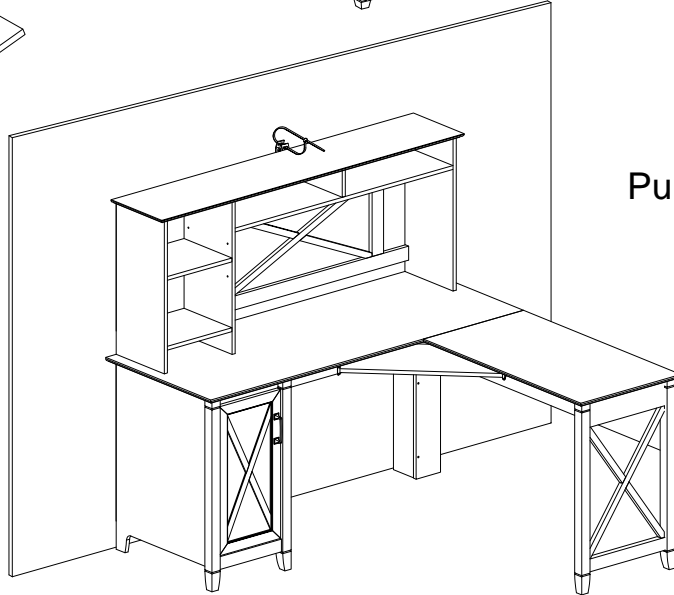
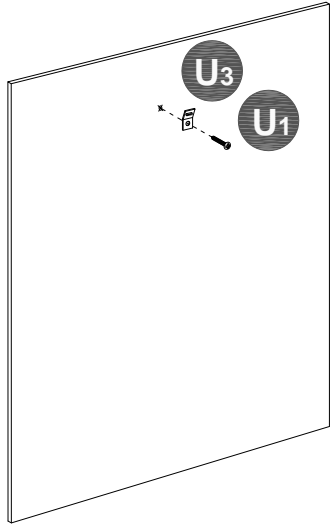
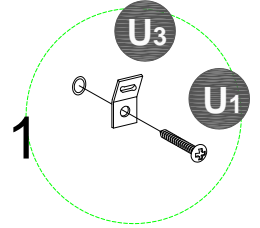
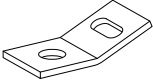

Pull to verify lock

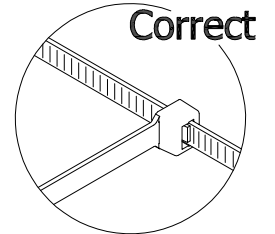
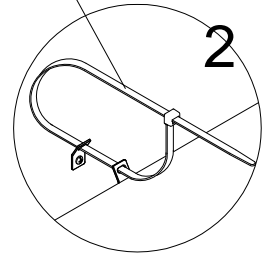

Maximum weight capacities

