

# CABINET

Assembly Instructions - Please keep for future reference



## Dimensions

Width - 31.1inch

Depth - 16.5inch

Height - 71inch

Important – Please read these instructions fully before starting assembly



# Safety and Care Advice

**Important – Please read these instructions fully before starting assembly**

- Check you have all the components and tools listed on the following pages.
- Remove all fittings from the plastic bags and separate them into their groups.
- Keep children and animals away from the work area, small parts could choke if swallowed.
- Make sure you have enough space to layout the parts before starting.

- During assembly do not stand or put weight on the product, this could cause damage.
- Assemble the item as close to its final position (in the same room) as possible.
- Assemble on a soft level surface to avoid damaging the unit or your floor.
- Parts of the assembly will be easier with 2 people.



- To reduce the likelihood of damaging your product please ensure that your power drill is set on a low torque setting.

## Care and maintenance

- Only clean using a damp cloth and mild detergent, do not use bleach or abrasive cleaners.
- From time to time check that there are no loose screws on this unit.
- This product should not be discarded with household waste. Take to your local authority waste disposal centre.

## Handy Hints

- Assemble all parts and bolts loosely during assembly, only once the product is complete should you fully tighten the bolts
- Regularly check and ensure that all bolts and fittings are tightened properly.

### **WARNING**

**In order to help prevent overturning – please follow these instructions**

To help prevent product toppling over please follow the below steps:-













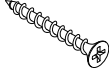

- Use the anti tip strap or wall fixing method provided (if applicable)
- Do not allow children to climb or hang on the furniture
- Do not open more than one drawer at a time
- Do not place heavy items in the top drawers
- Do not place heavy items on top of the furniture, unless the furniture has been designed for this purpose

Please note that only the anti tip strap is provided.  
You will need to provide wall plugs and screws applicable for your wall type

# Components - Fittings

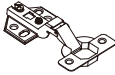
Please check you have all the fittings listed below

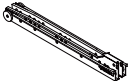
**Note:** The quantities below are the correct amount to complete the assembly. In some cases more fittings may be supplied than are required.

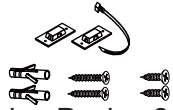
<b>A</b>  Cam Bolt x 46	<b>B</b>  Cam Lock x 46	<b>C</b>  8*30mm Wooden Dowel x 32
<b>D</b>  3.5*14mm Screw x 64	<b>E</b>  5*40mm Screw x 17	<b>F</b>  5*23mm Screw x 4
<b>G</b>  Bracket x 1	<b>H</b>  Door Stopper x 1	<b>I</b>  Back Panel Stiffener x 12
<b>J</b>  Shelf Support Pin x 8	<b>K</b>  Hinge x 6	<b>L</b>  Handle & Fixings x 2
<b>M</b>  Drawer slide x 2	<b>N</b>  H Bar x 1	<b>O</b>  Wall Fixing Pack x 2

## Tools required

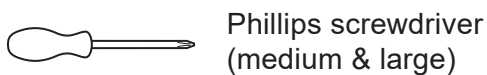

## Ruler - Use this ruler to help correctly identify the screws

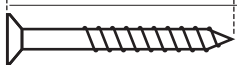
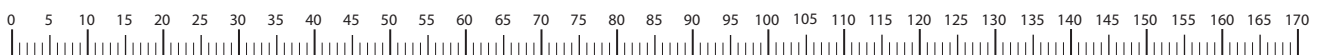

The screws length is measured from the head to the point (30mm screw shown).

# Using Camlocks

## Step 1

Connect the male camlock as directed in the assembly instructions using a screwdriver.

1

DO NOT OVER TIGHTEN.  
NE PAS SERRER EXCESSIVEMENT.

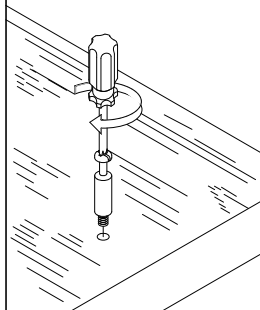

## Step 2

Push the male camlock into the entry hole.

2

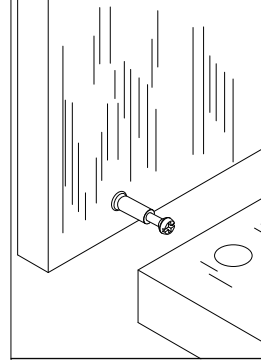

## Step 3

Insert the female camlock as shown in the instructions.

Note: ensure that the arrow on the top of the camlock points towards the entry hole for the male camlock.

3

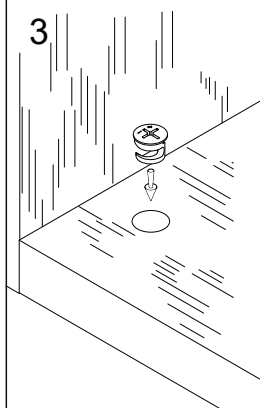

## Step 4

Turn the female camlock clockwise with a screwdriver.

You should feel a click when the camlock is locked in place.

The joint is now secure.

4

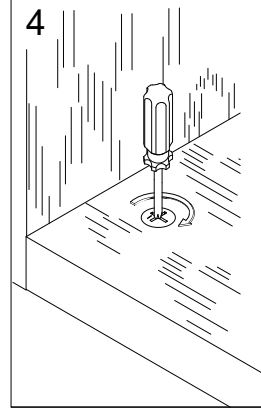

# Components - Panels

Please check you have all the panels listed below

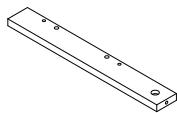

**1** (5 x 37.9 x 1.5cm) x2

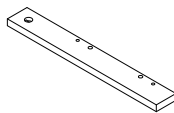

**2** (5 x 37.9 x 1.5cm) x2

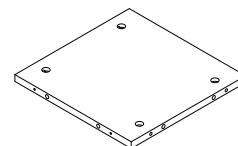

**3** (29.6 x 29.1 x 1.5cm) x1

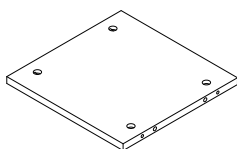

**4** (29.6 x 29.1 x 1.5cm) x1

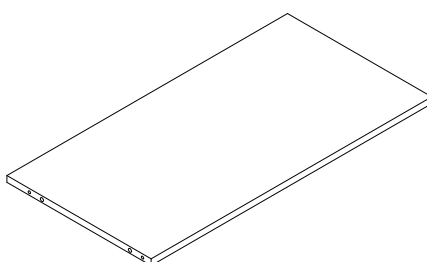

**5** (36.7 x 71.4 x 1.5cm) x1

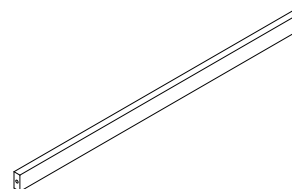

**6** (3.6 x 71.4 x 1.5cm) x1

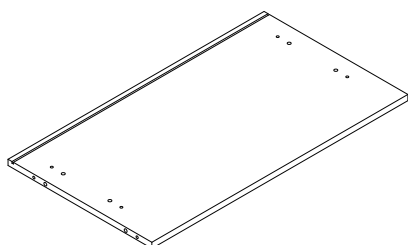

**7** (40.1 x 71.4 x 1.5cm) x1

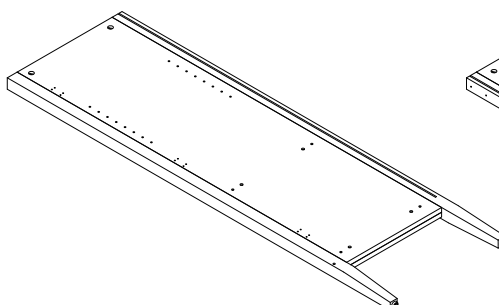

**8** (41.8 x 140 x 3.6cm) x1

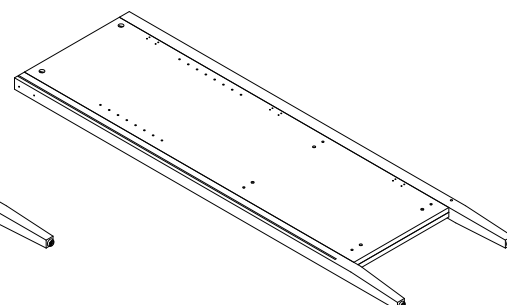

**9** (41.8 x 140 x 3.6cm) x1

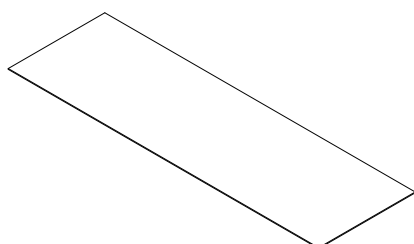

**10** (36 x 115.7 x 0.27cm) x2

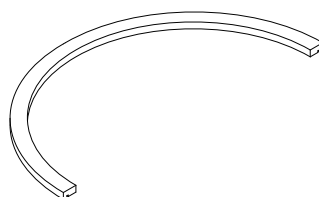

**11** (39x 78.6 x 1.8cm) x1

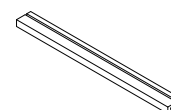

**12** (3.6 x 38.5 x 1.5cm) x2

# Components - Panels

Please check you have all the panels listed below

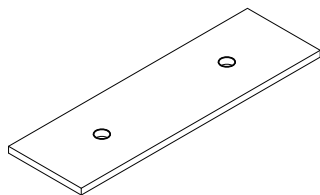

**13** (18.5 x 60.8 x 1.5cm) x2

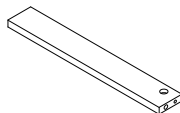

**14** (6 x 38.5 x 1.5cm) x3

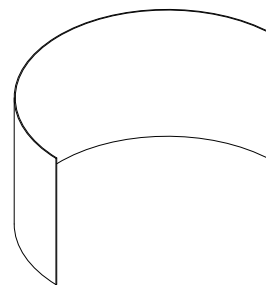

**15** (39.3 x 117.8 x 0.27cm) x1

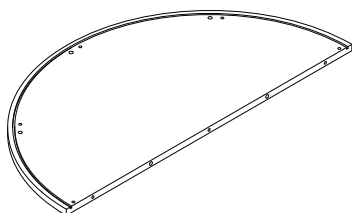

**16** (39 x 78.6 x 1.5cm) x1

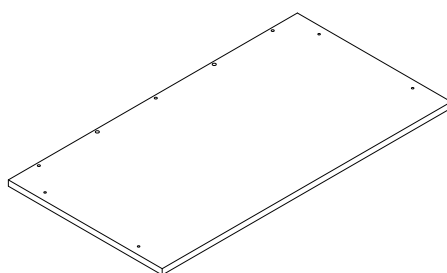

**17** (42.1 x 79.1 x 1.5cm) x1

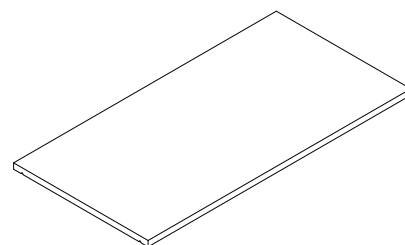

**18** (36.6 x 71.3 x 1.5cm) x2

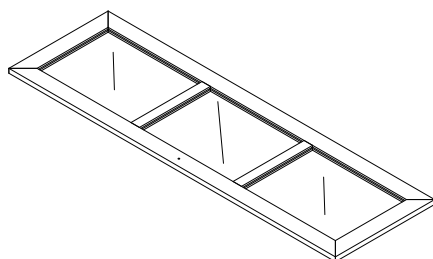

**19** (35.2 x 115.8 x 1.5cm) x2

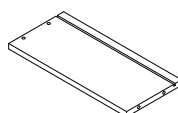

**20** (14 x 30 x 1.2cm) x2

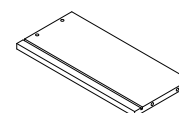

**21** (14 x 30 x 1.2cm) x2

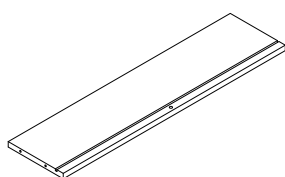

**22** (14 x 56.5 x 1.2cm) x2

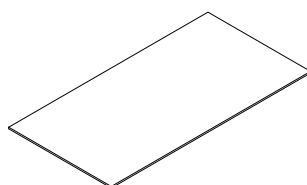

**23** (29.5 x 27 x 1.5cm) x2

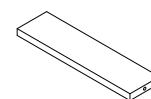

**24** (7.5 x 28.7 x 1.5cm) x2

# Assembly Instructions

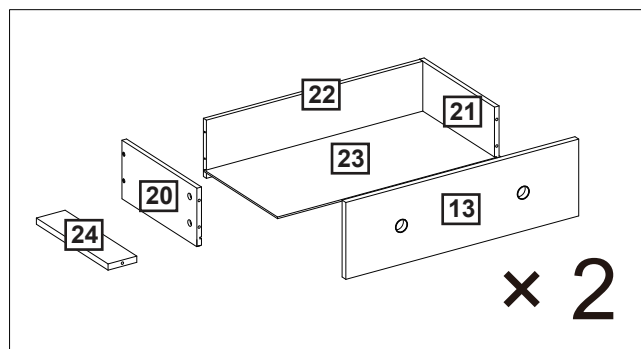
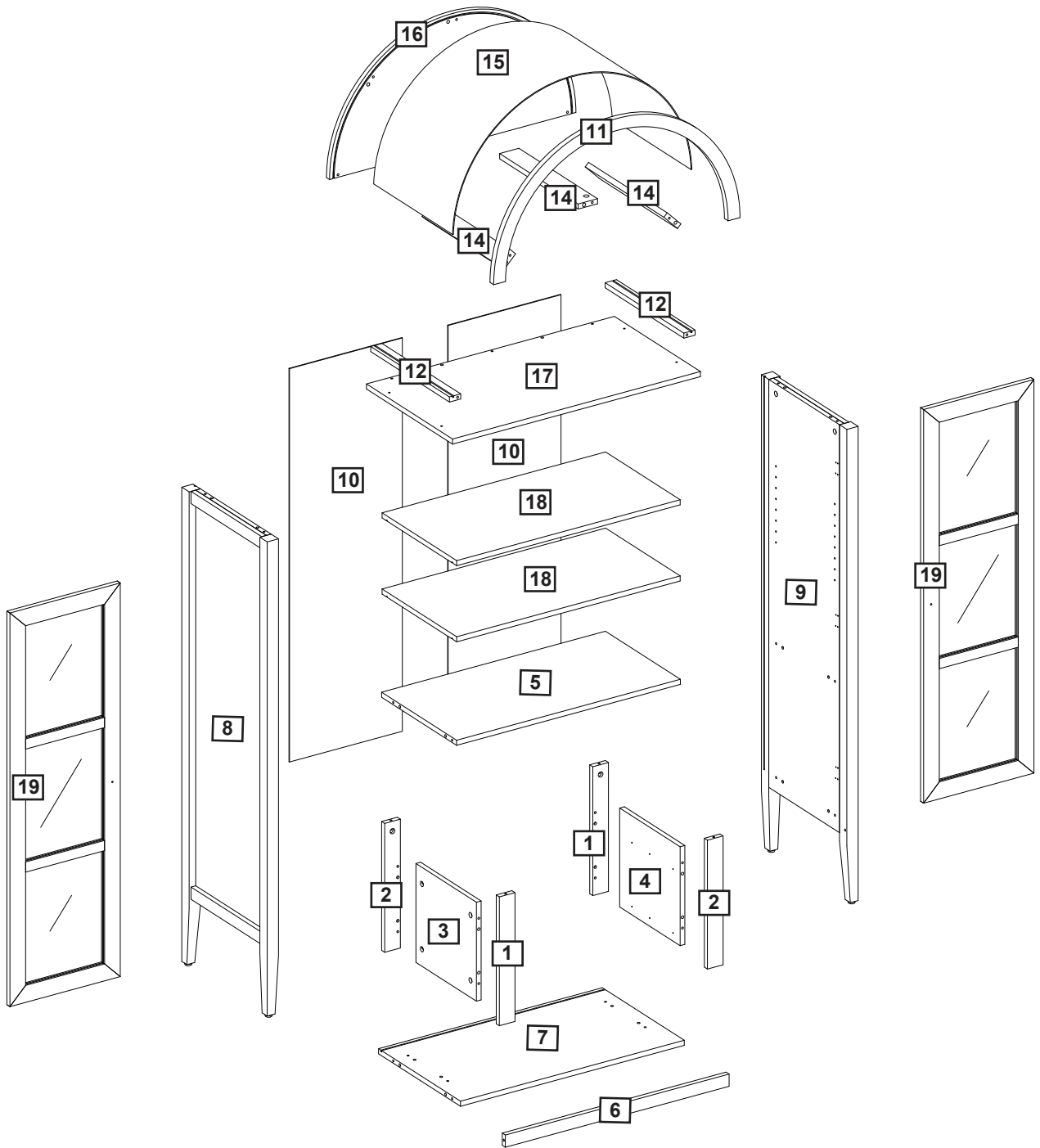

# Assembly Instructions

## Step 1

### CAM-LOCK

Tighten until shoulder is flush with panel. Do not overtighten or undertighten (see example below)

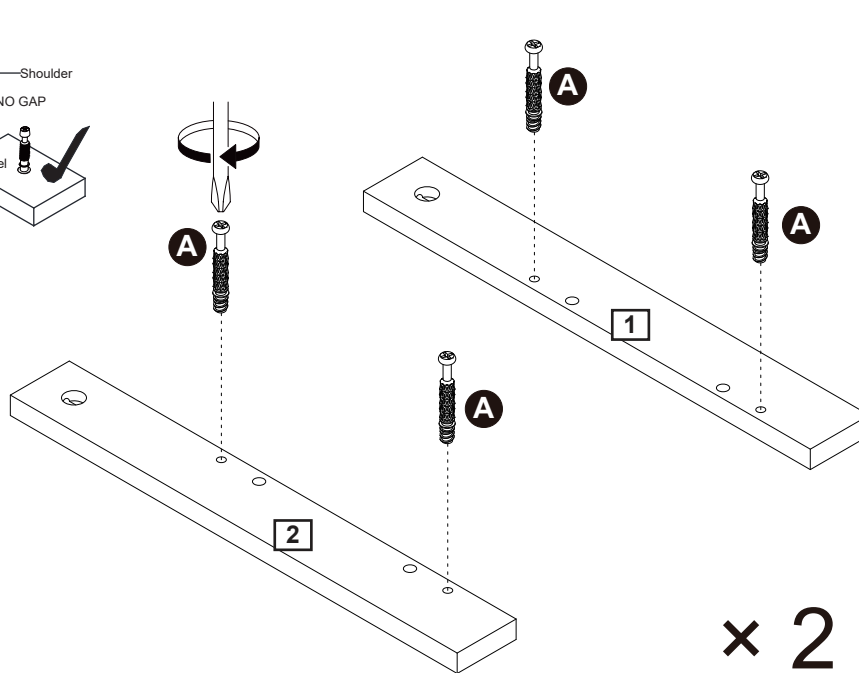
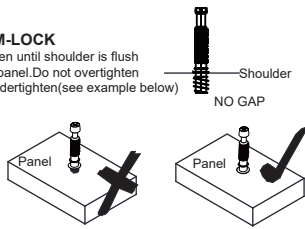

Attach cam bolt (A) to part (1, 2) with a screwdriver.

## Step 2

C



C x 12

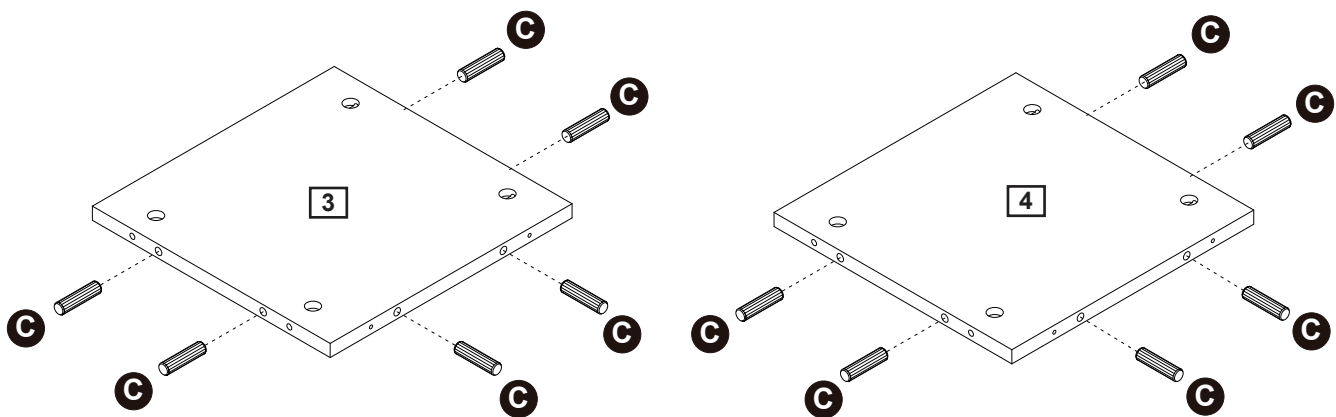

Attach part (1, 2) to part (3), then insert and secure cam lock (B) to part (3) to lock it.

Insert wooden dowel (C) into part (3, 4).

# Assembly Instructions

## Step 3

**B**   
B x 4

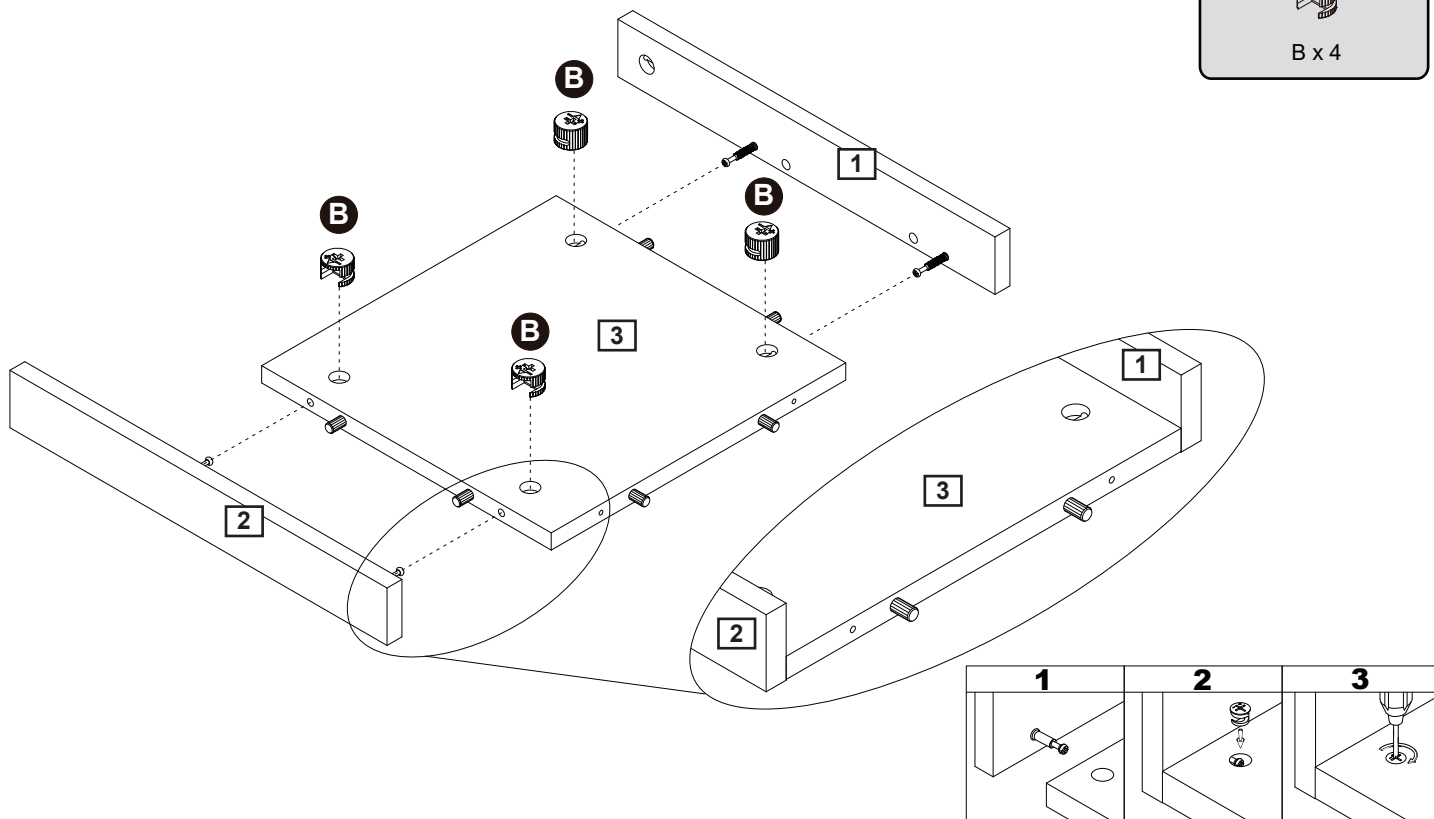

Attach part (1, 2) to part (3), then insert and secure cam lock (B) to part (3) to lock it.

## Step 4

**B**   
B x 4

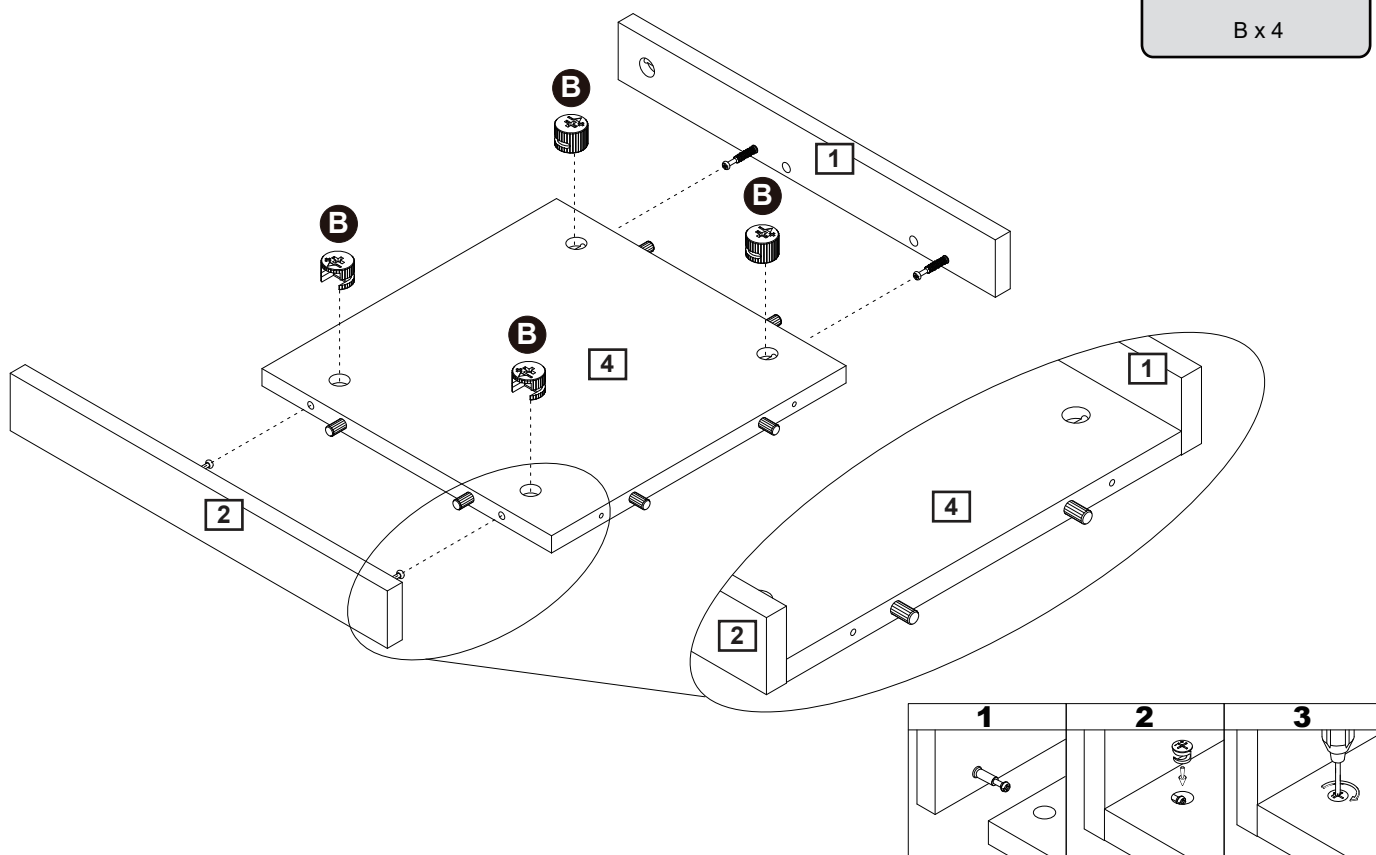

Attach part (1, 2) to part (4), then insert and secure cam lock (B) to part (4) to lock it.

# Assembly Instructions

## Step 5

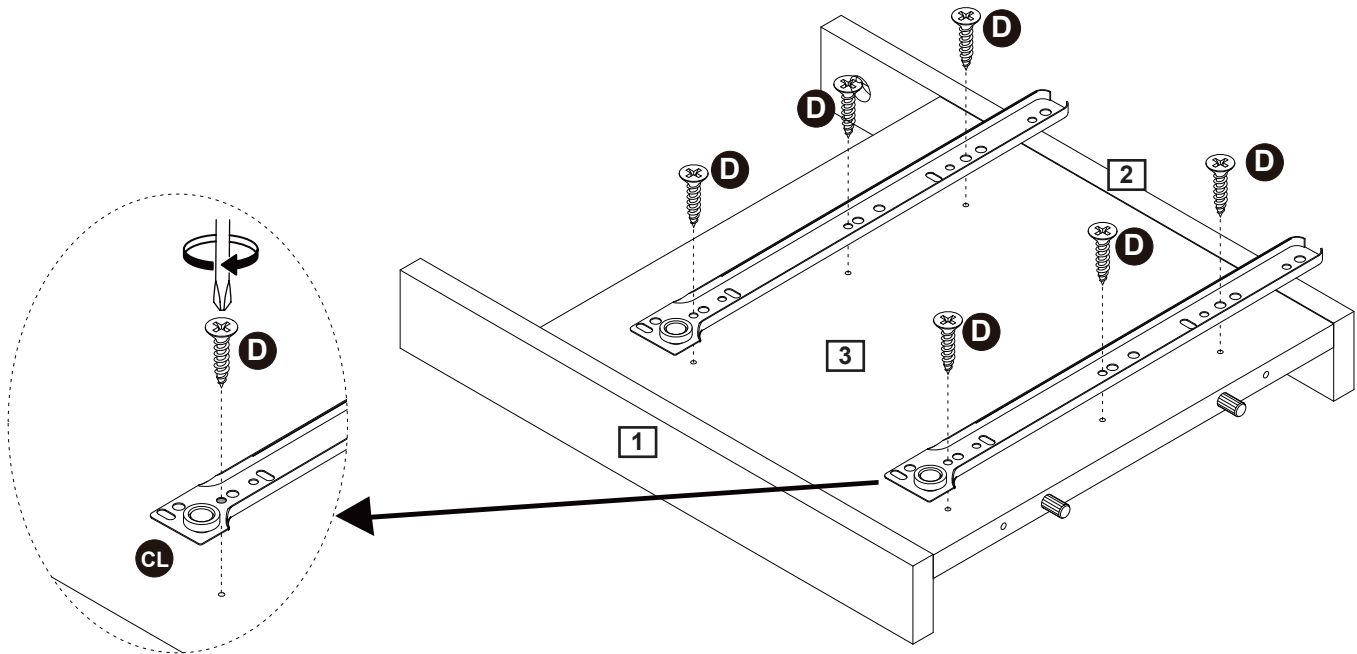
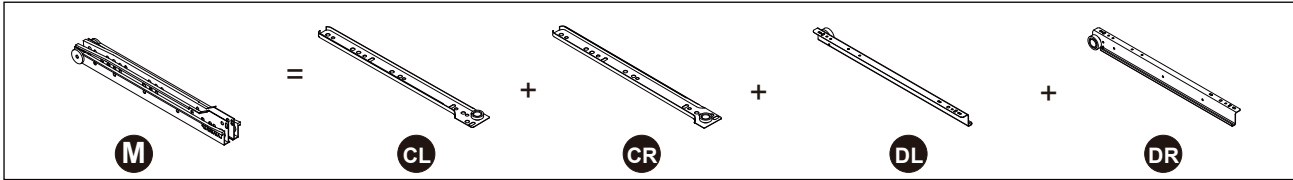
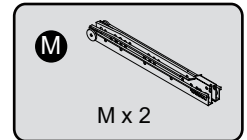

Use screw (D) to secure slide track (CL) to part (3) with a screwdriver.

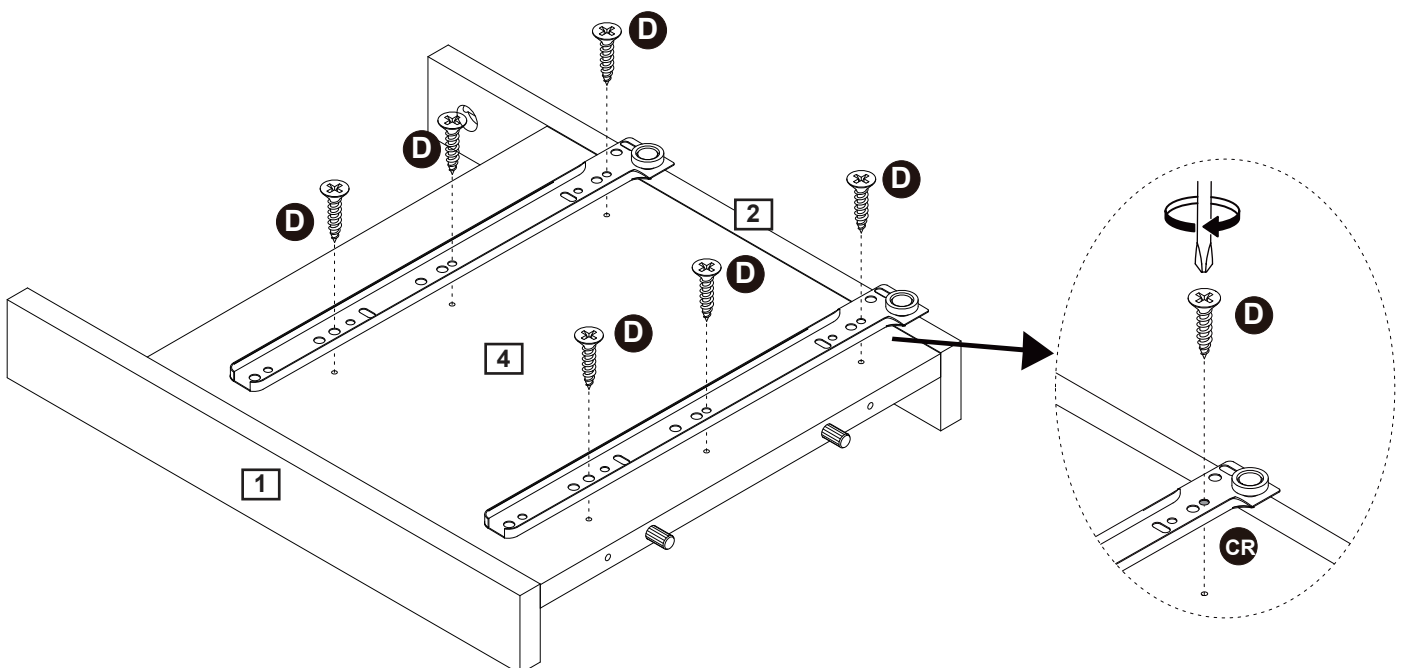

Use screw (D) to secure slide track (CR) to part (4) with a screwdriver.

# Assembly Instructions

## Step 6

### CAM-LOCK

Tighten until shoulder is flush with panel. Do not overtighten or undertighten (see example below)

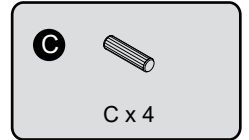
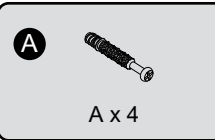
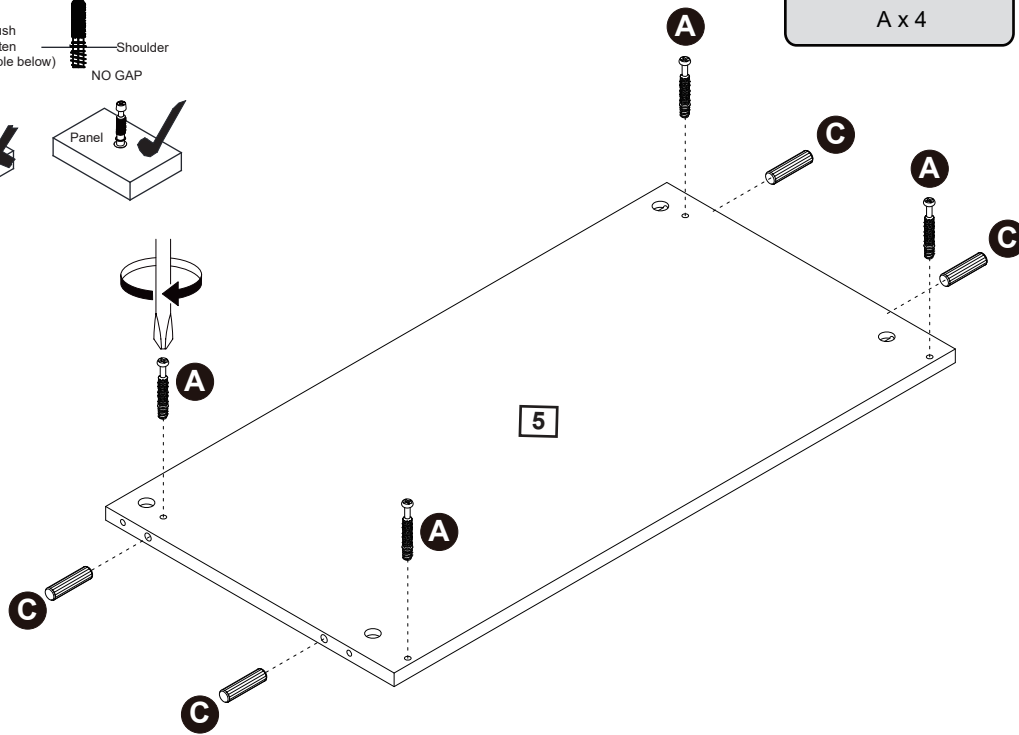
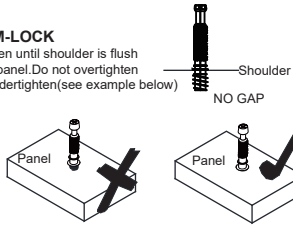

Attach cam bolt (A) to part (5) with a screwdriver.  
Insert wooden dowel (C) into part (5).

## Step 7

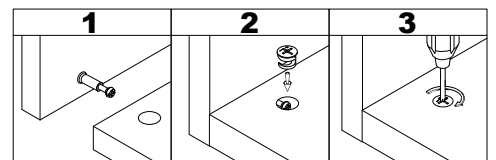
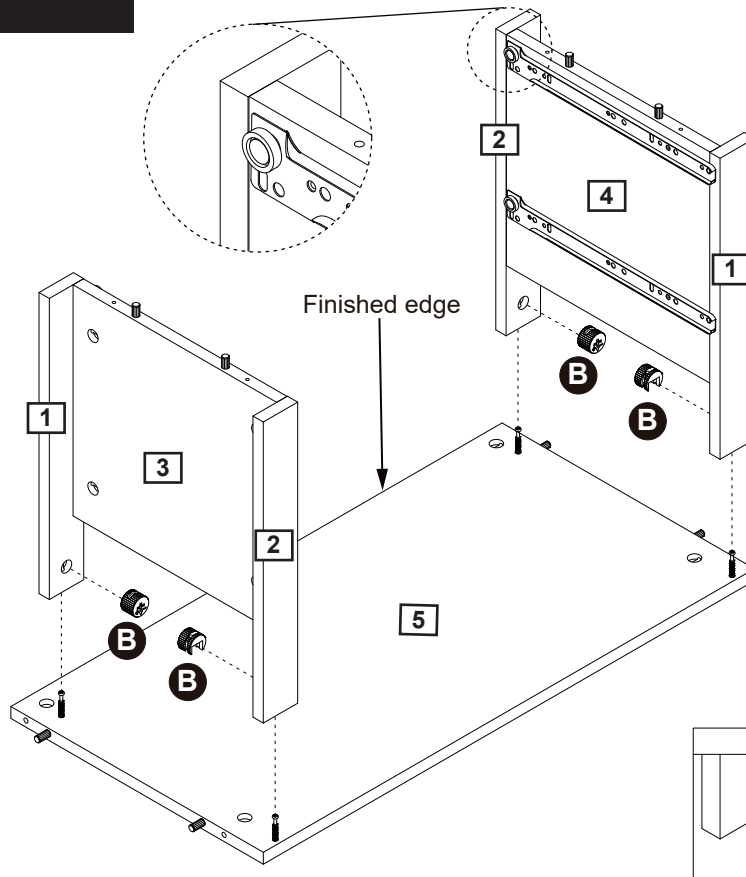

Attach part (1, 2) to part (5), then insert and secure cam lock (B) to part (1, 2) to lock it.

# Assembly Instructions

## Step 8

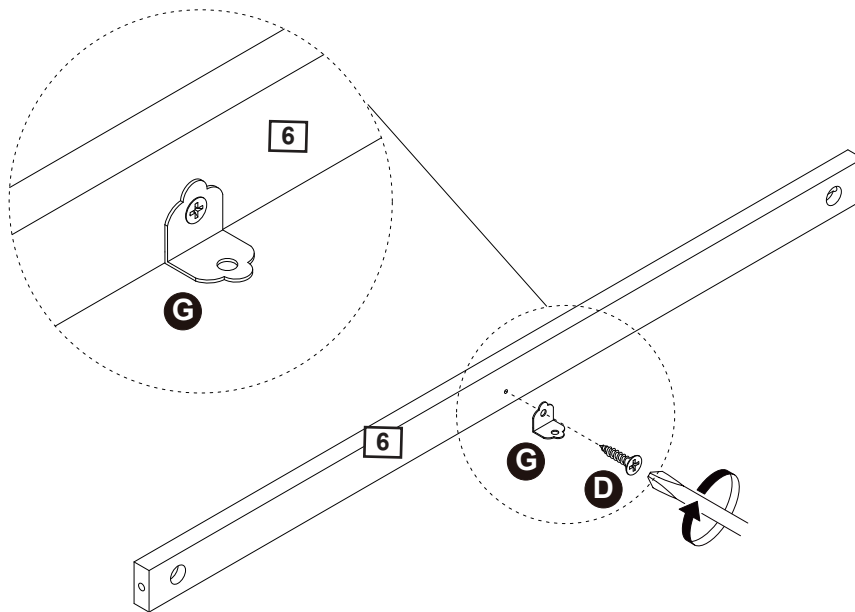
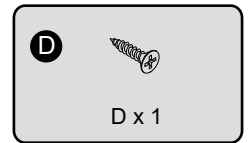

Attach bracket (G) to part (6) using screw (D) with a screwdriver.

## Step 9

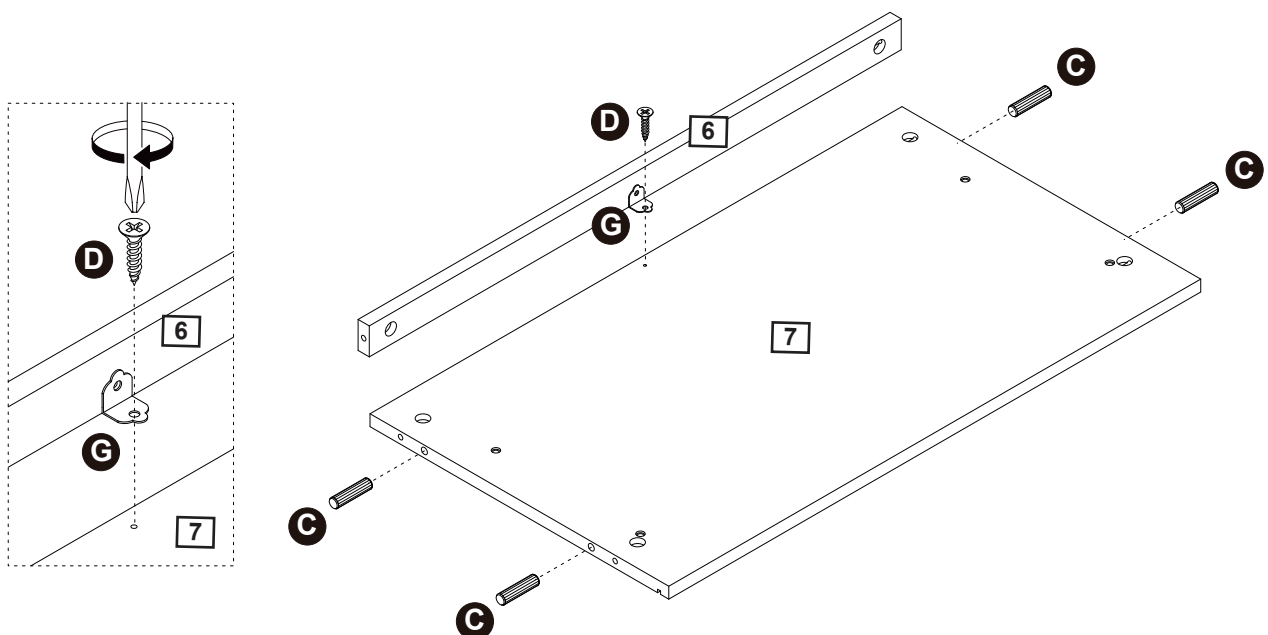
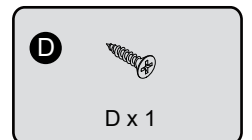
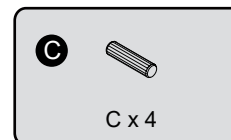

Attach bracket (G) to part (7) using screw (D) with a screwdriver.  
Insert wooden dowel (C) into part (7).

# Assembly Instructions

## Step 10

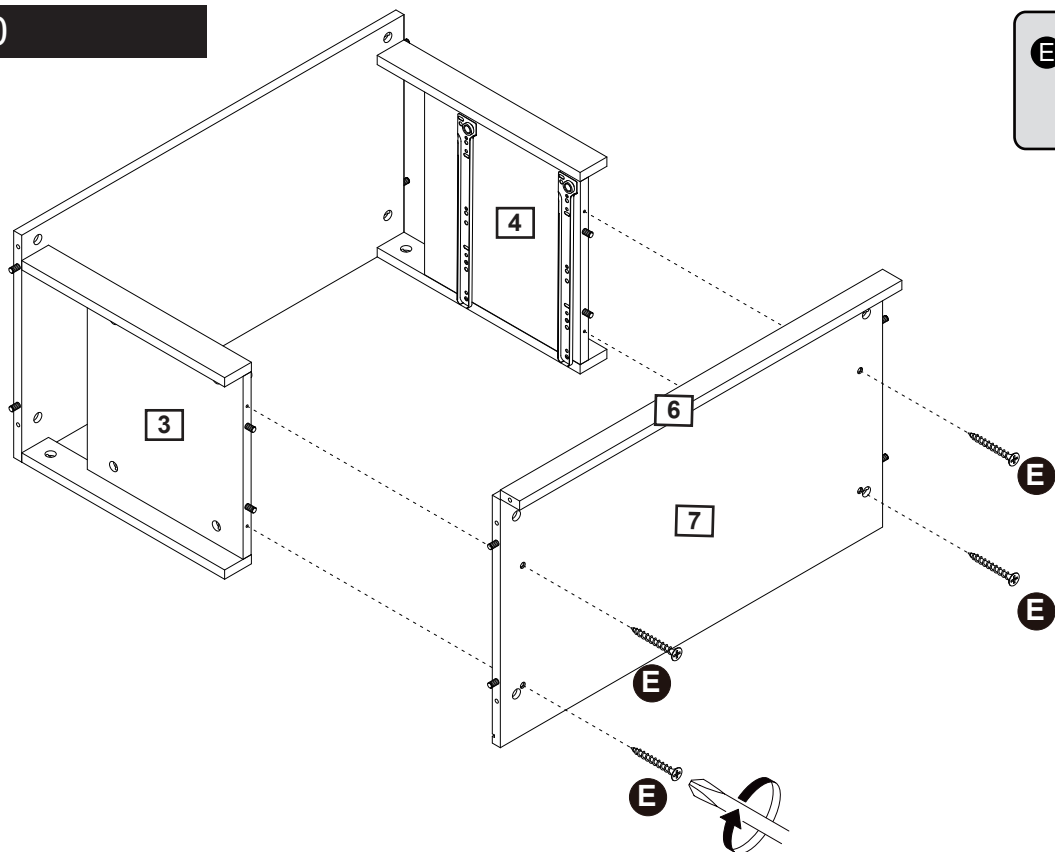

**E**   
E x 4

Attach part (7) to part (3, 4) using screw (E) with a screwdriver.

## Step 11

### CAM-LOCK

Tighten until shoulder is flush with panel. Do not overtighten or undertighten (see example below).

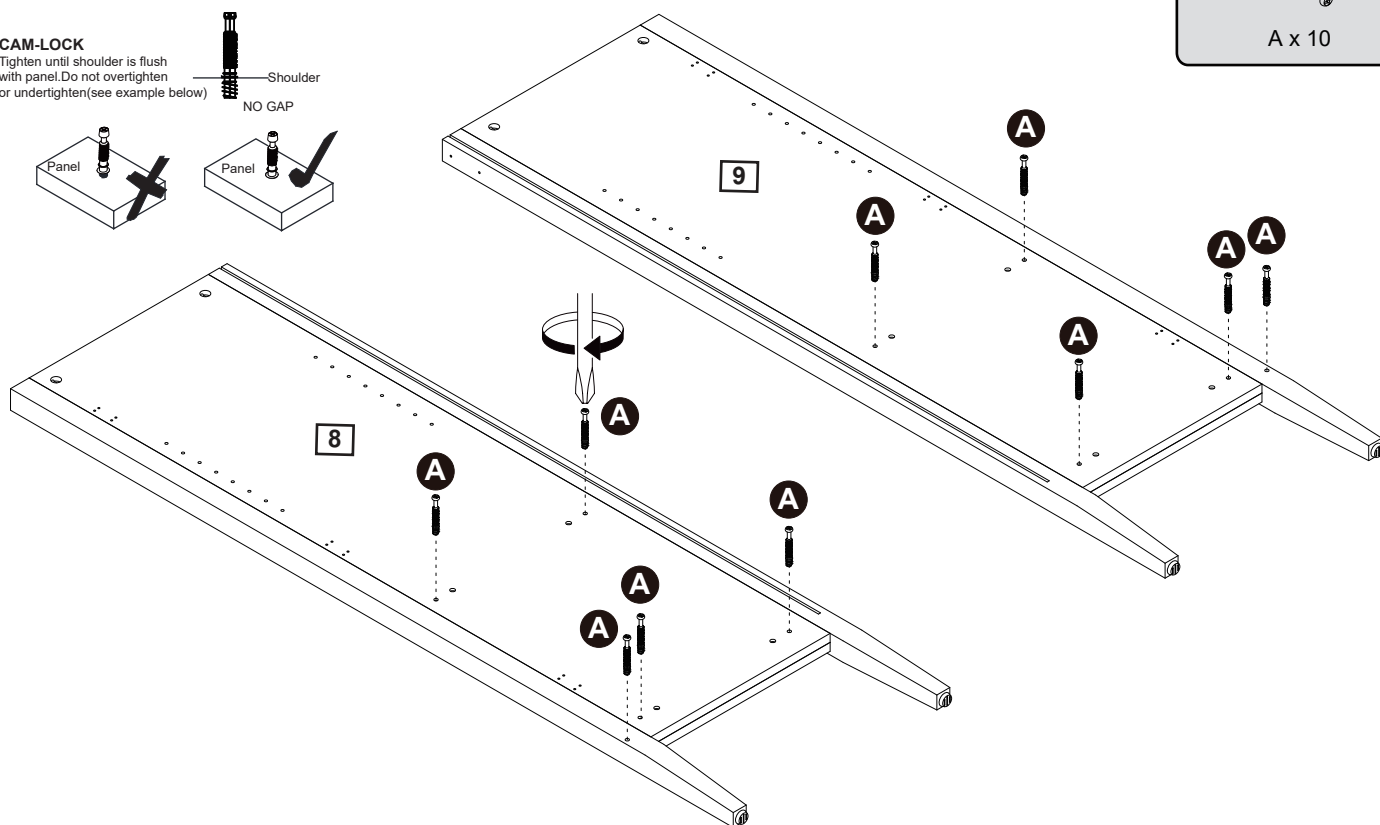
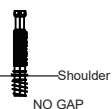

**A**   
A x 10

Attach cam bolt (A) to part (8, 9) with a screwdriver.

# Assembly Instructions

## Step 12

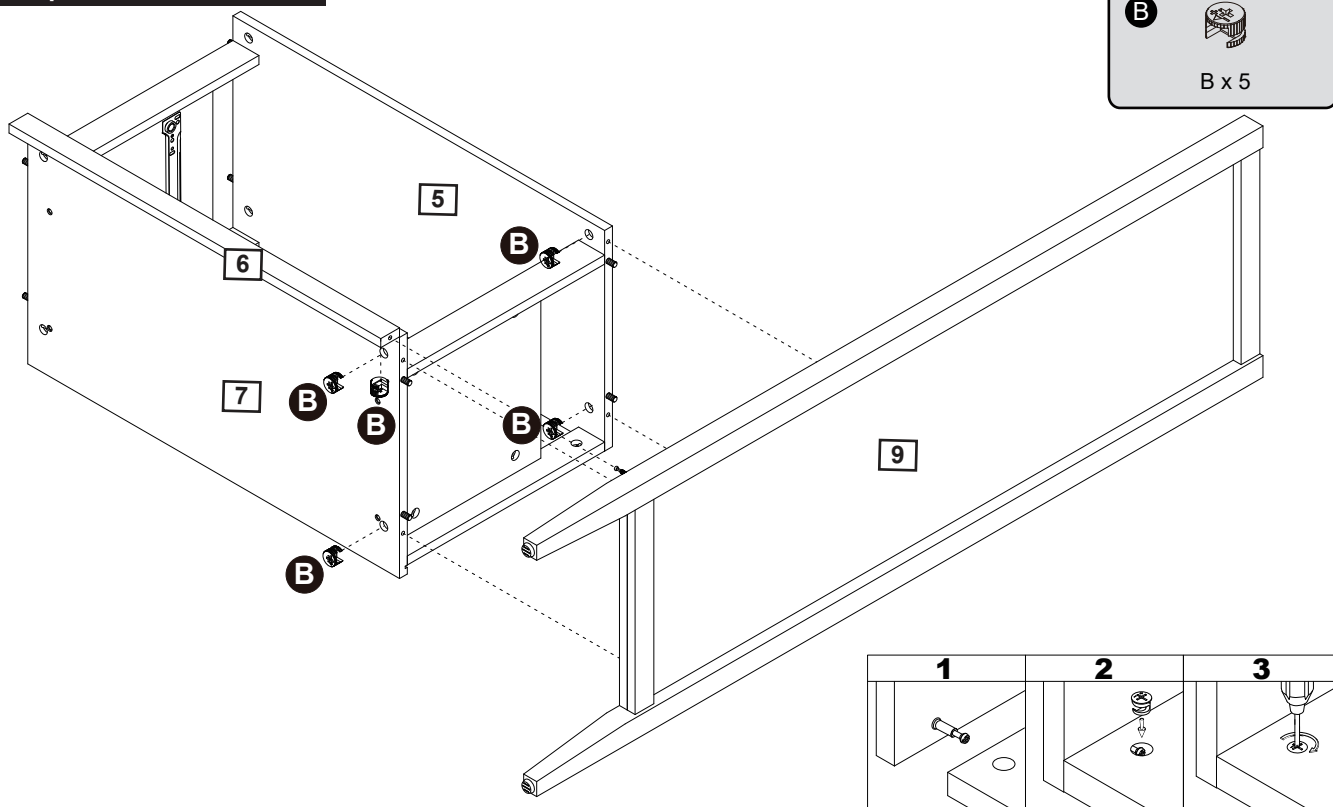

Attach part (9) to part (5, 6, 7), then insert and secure cam lock (B) to part (5, 6, 7) to lock it.

## Step 13

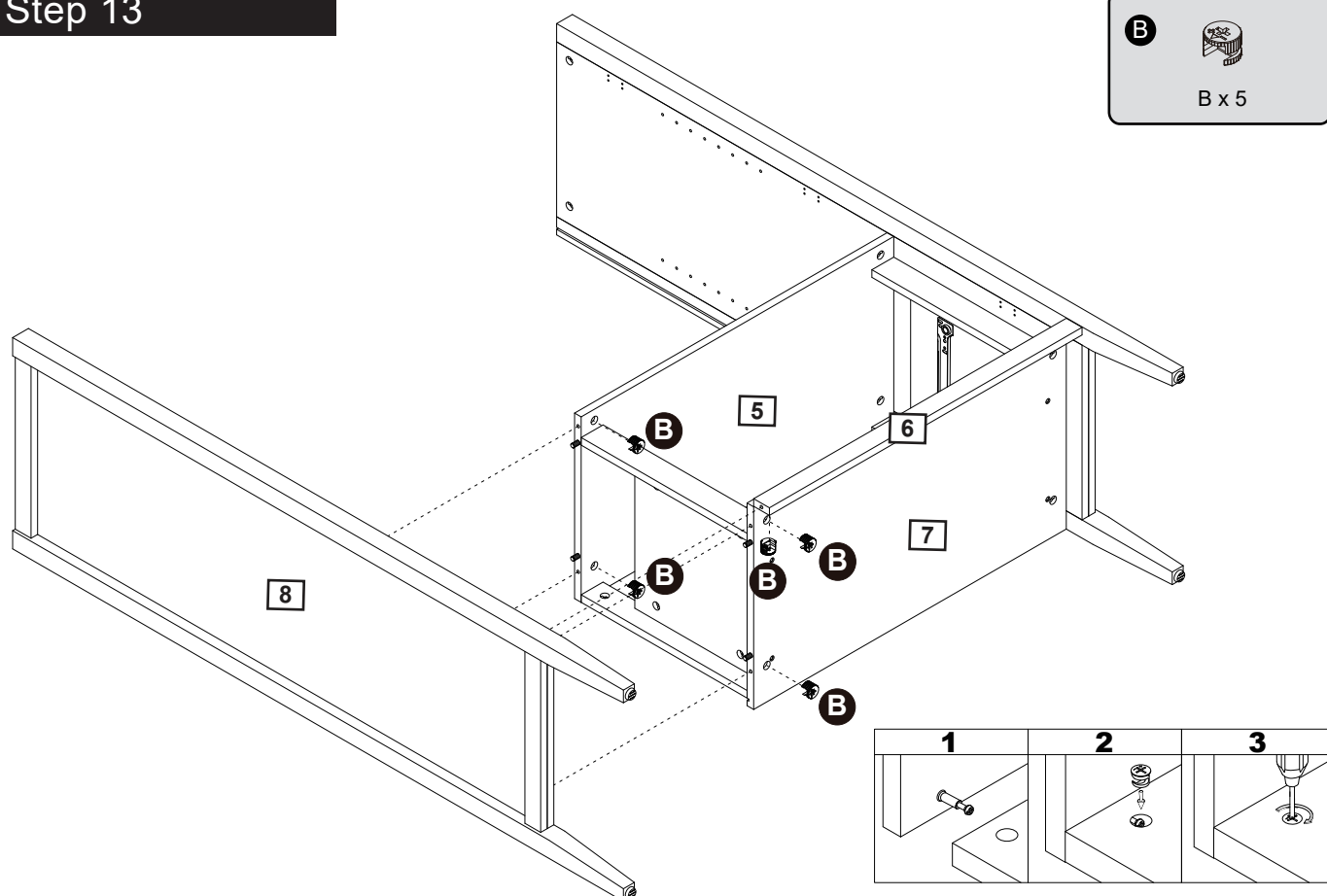

Attach part (8) to part (5, 6, 7), then insert and secure cam lock (B) to part (5, 6, 7) to lock it. 13

# Assembly Instructions

## Step 14

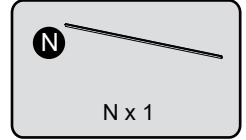
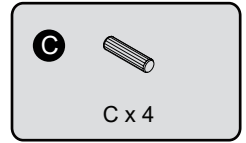
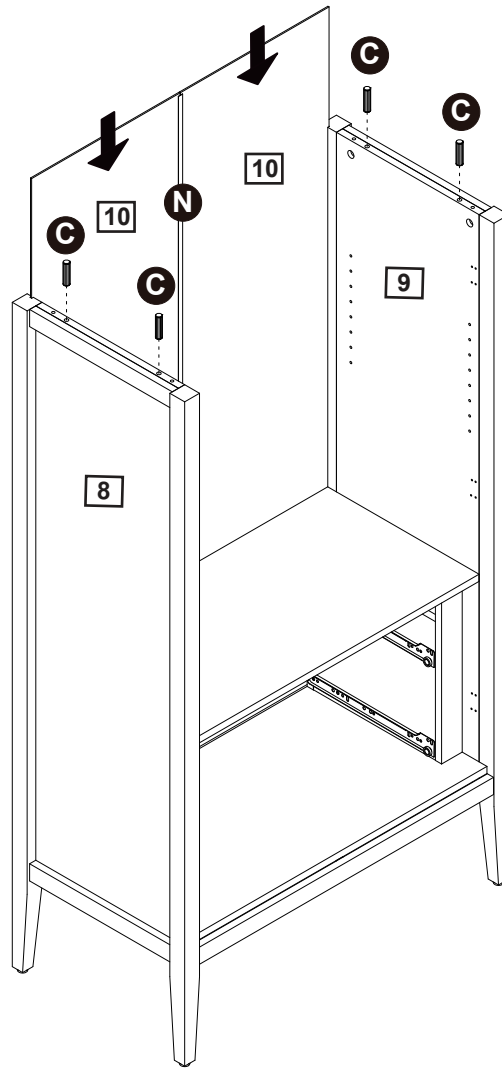
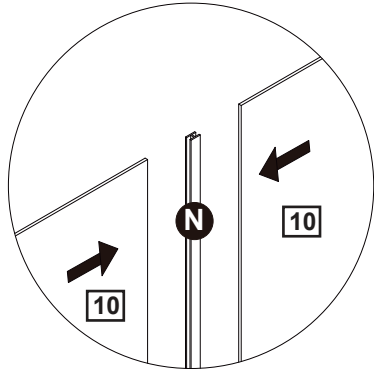

Slide back panel (10) into grooves as per diagram.  
Insert wooden dowel (C) into part (8, 9).

## Step 15

### CAM-LOCK

Tighten until shoulder is flush with panel. Do not overtighten or undertighten (see example below)

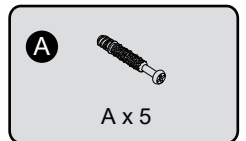
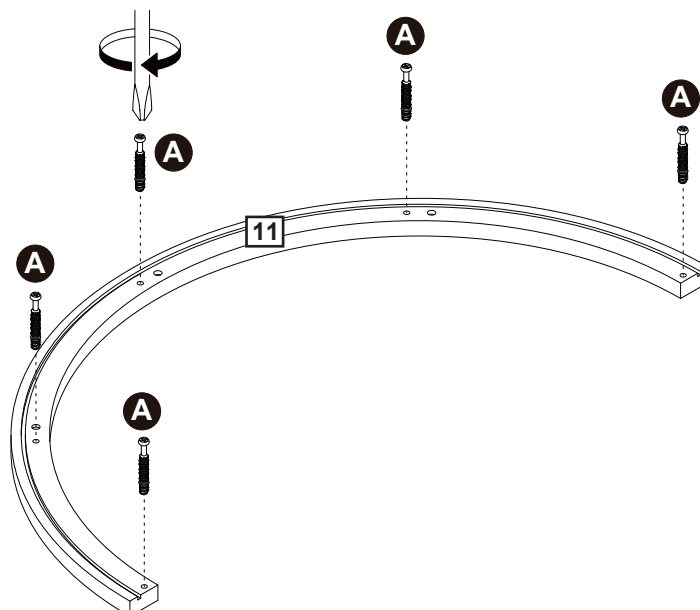
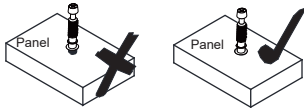
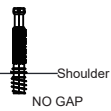

Attach cam bolt (A) to part (11) with a screwdriver.



# Assembly Instructions

## Step 18

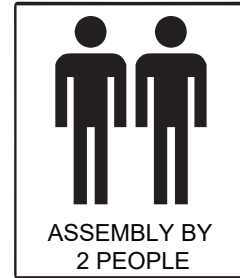
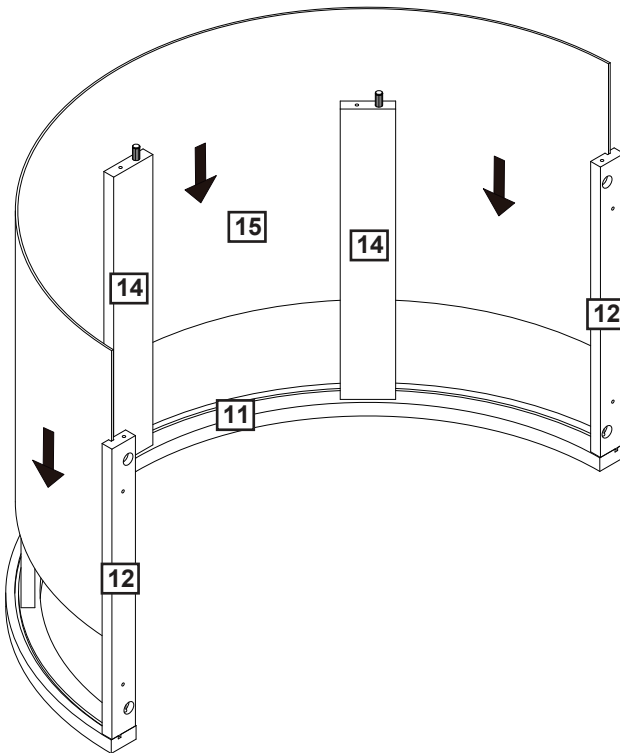

Slide part (15) into grooves as per diagram.

## Step 19

### CAM-LOCK

Tighten until shoulder is flush with panel. Do not overtighten or undertighten (see example below)

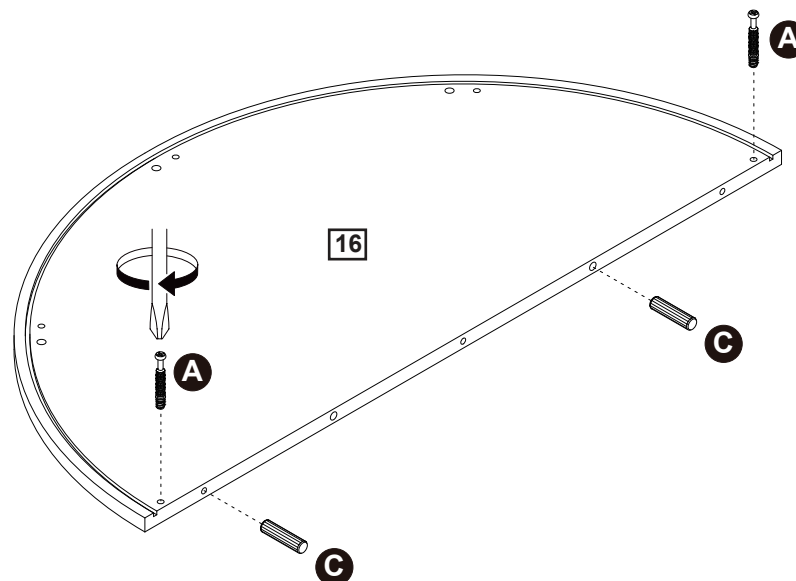
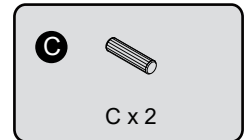
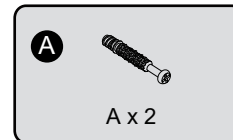
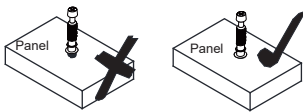
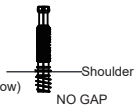

Attach cam bolt (A) to part (16) with a screwdriver.  
Insert wooden dowel (C) into part (16).

# Assembly Instructions

## Step 20

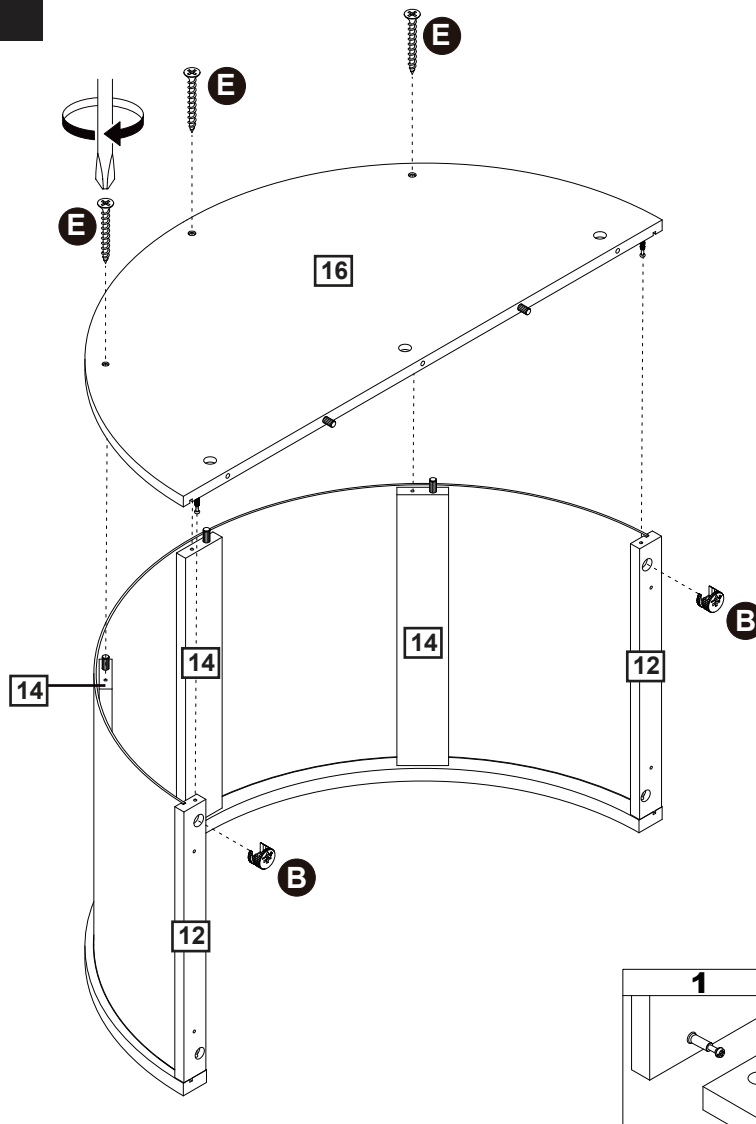

**B**   
B x 2

**E**   
E x 3

Attach part (16) to part (12,14), then insert and secure cam lock (B) to part (12) to lock it.  
Attach part (16) to part (14) using screw (E) with a screwdriver.

## Step 21

**CAM-LOCK**  
Tighten until shoulder is flush with panel. Do not overtighten or undertighten (see example below)

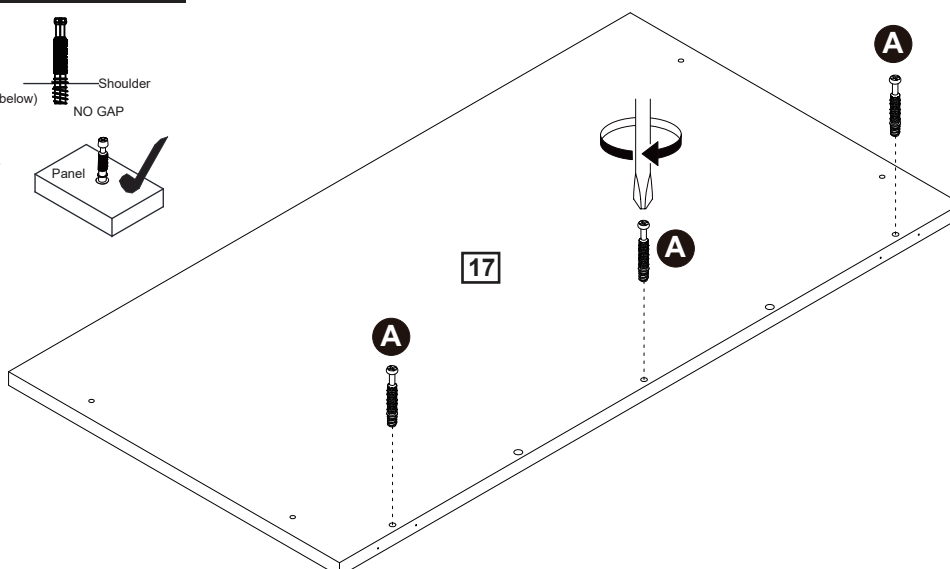
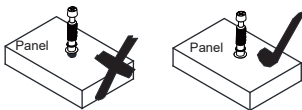

**A**   
A x 3

Attach cam bolt (A) to part (17) with a screwdriver.

# Assembly Instructions

## Step 22

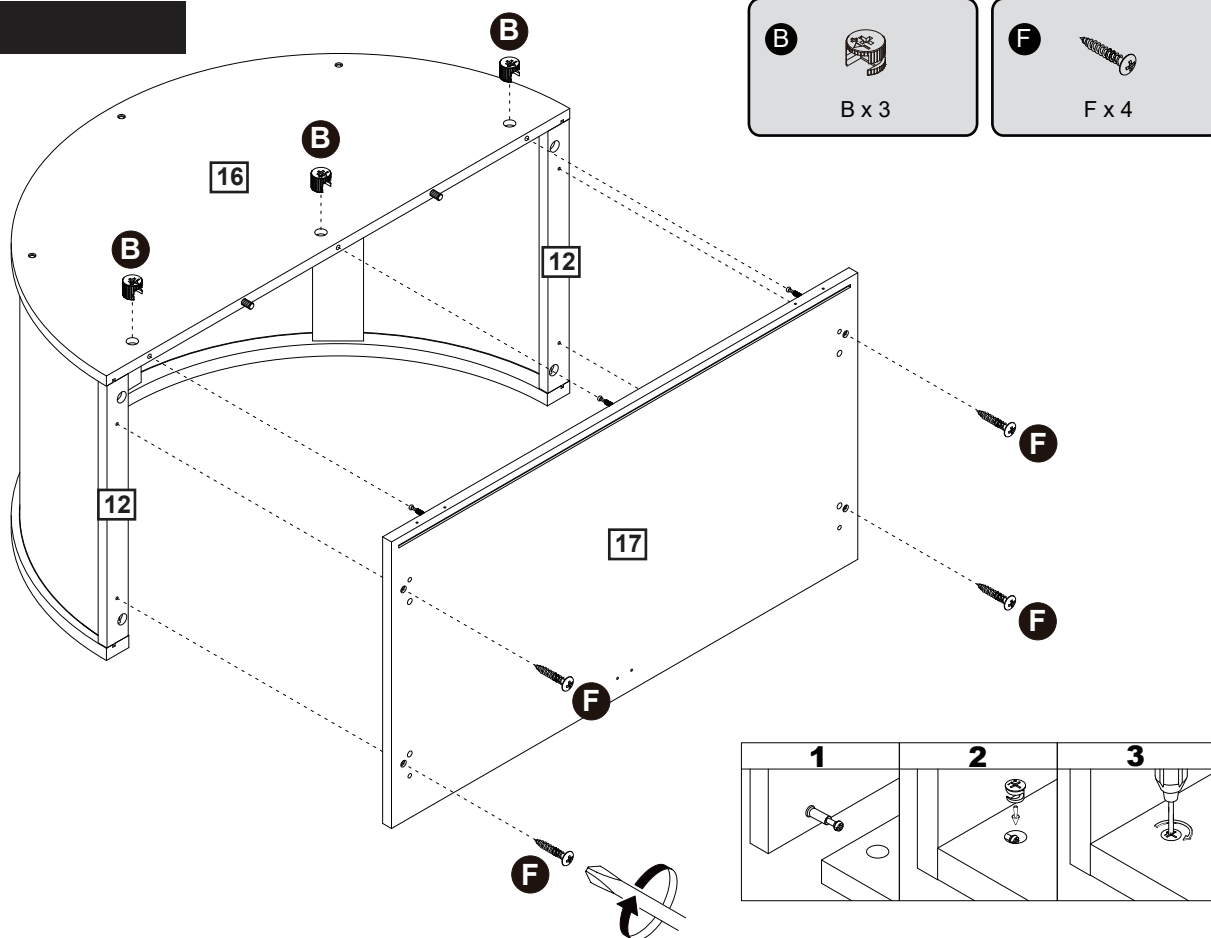

Attach part (17) to part (12,16) using screw (F) with a screwdriver, then insert and secure cam lock (B) to part (16) to lock it.

## Step 23

### CAM-LOCK

Tighten until shoulder is flush with panel. Do not overtighten or undertighten (see example below)

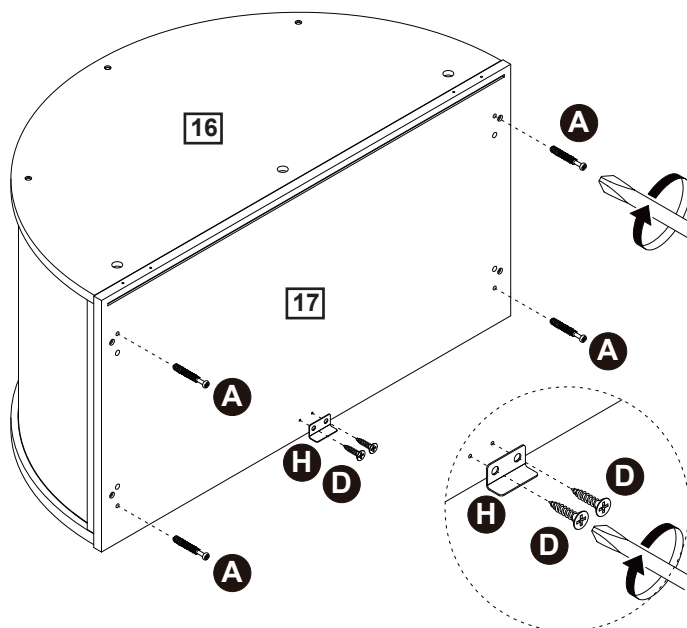
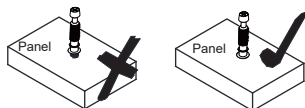
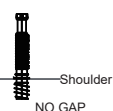

Attach cam bolt (A) to part (17) with a screwdriver.  
Attach door stopper (H) to part (17) using screw (D) with a screwdriver.

# Assembly Instructions

## Step 24

**B**



B x 4

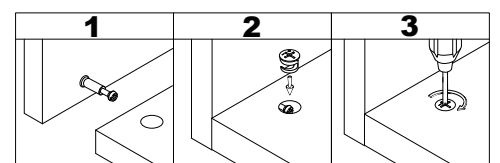
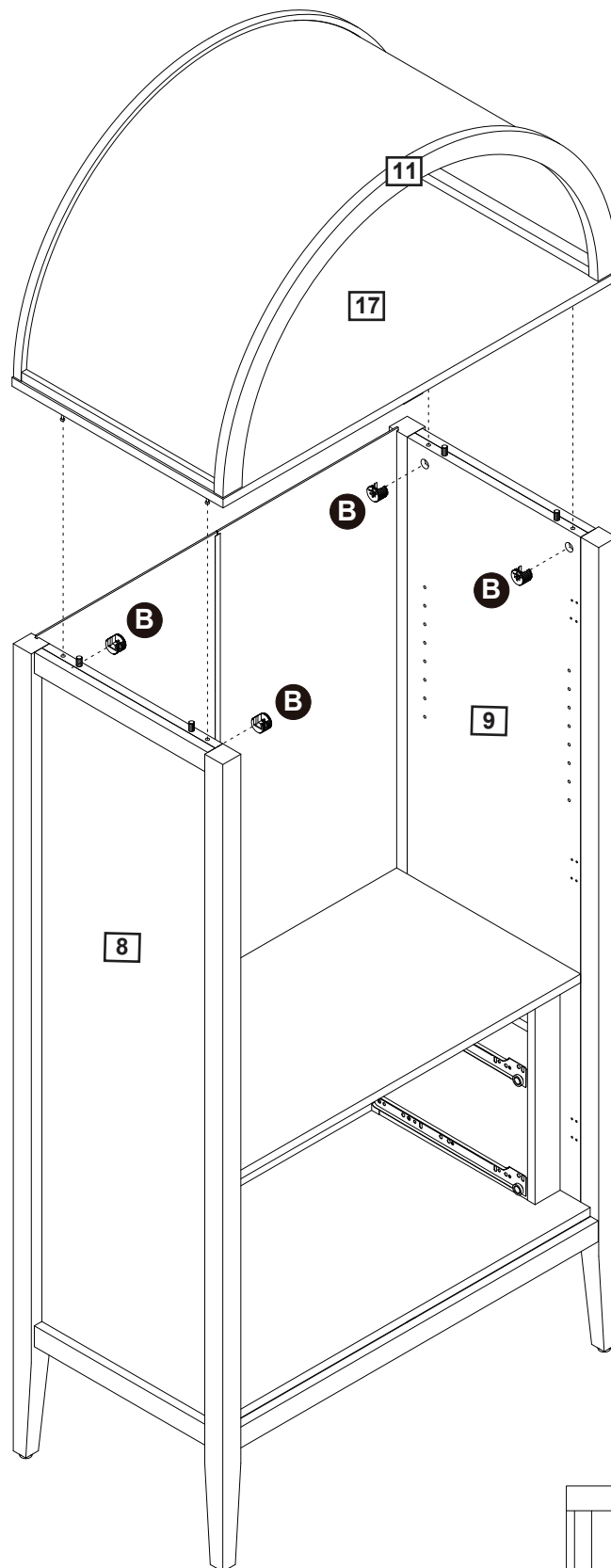

Attach part (17) to part (8, 9), then insert and secure cam lock (B) to part (8, 9) to lock it.

# Assembly Instructions

## Step 25

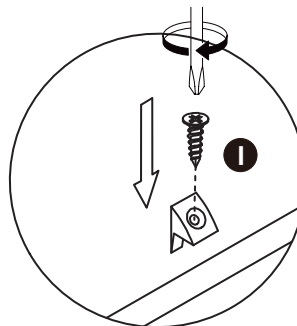
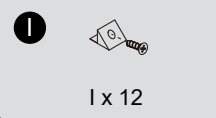
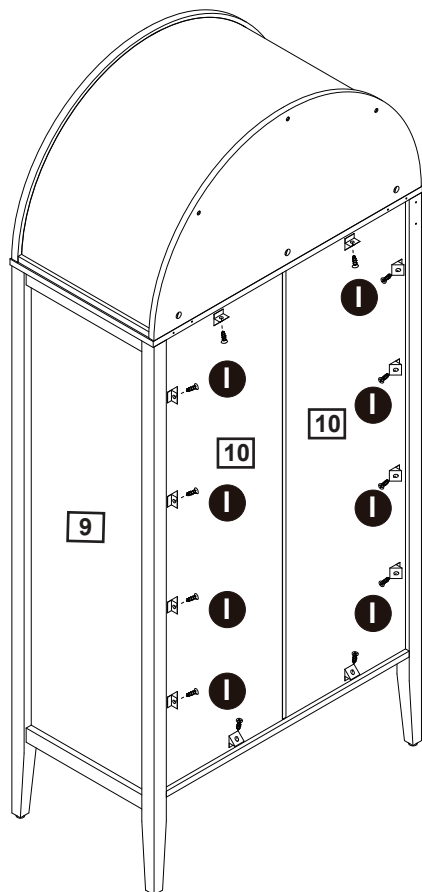

Secure back panel (10) using screw (I) with a screwdriver.

## Step 26

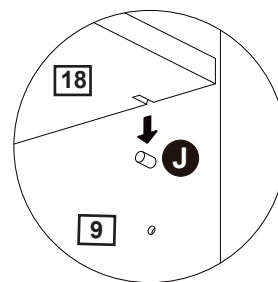
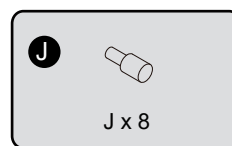
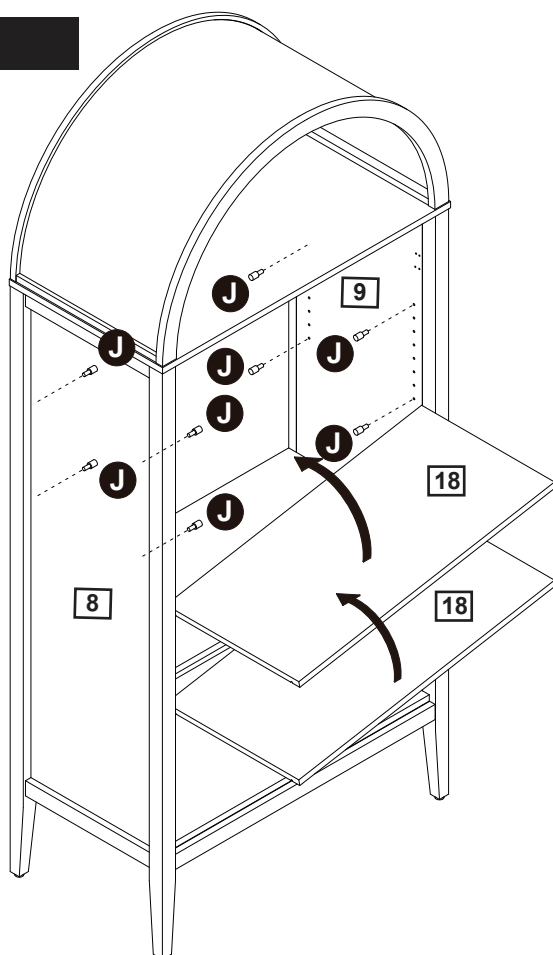

Insert shelf support pin (J) into part (8, 9).  
Place part (18) on the top of support pins.



# Is your cabinet door looking crooked or unevenly spaced?

If you're still having trouble lining everything up, your next step should be to try to adjust the feet slightly to square up the cabinet and doors. Follow the instructions below:

If the right door appears to be hanging low, you can adjust the adjustable leveler on the front right until the door is better aligned.

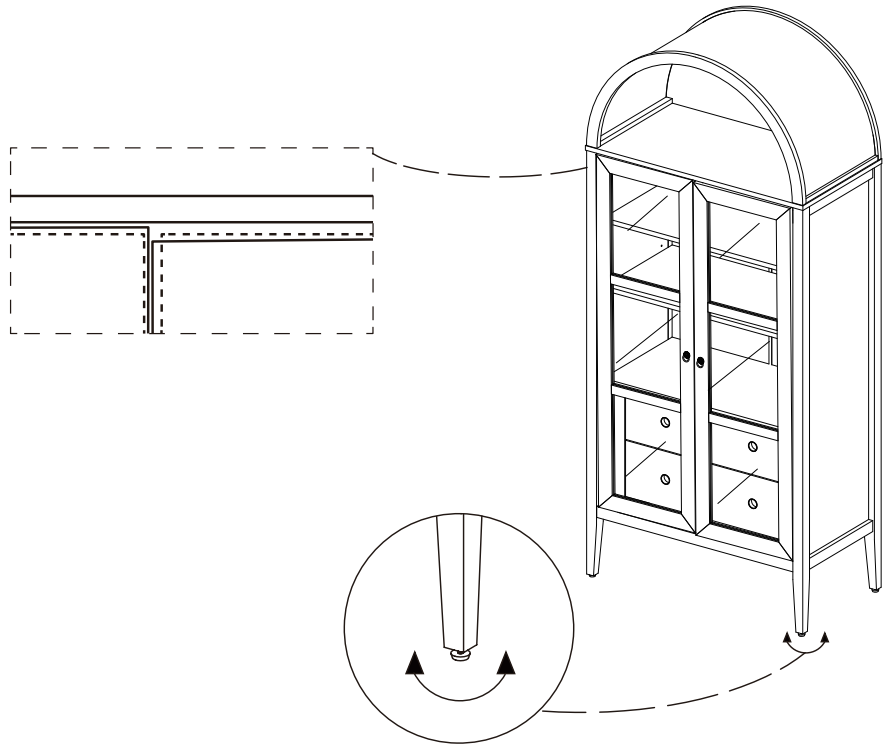

If the left door appears to be hanging low, you can adjust the adjustable leveler on the front left until the door is better aligned.

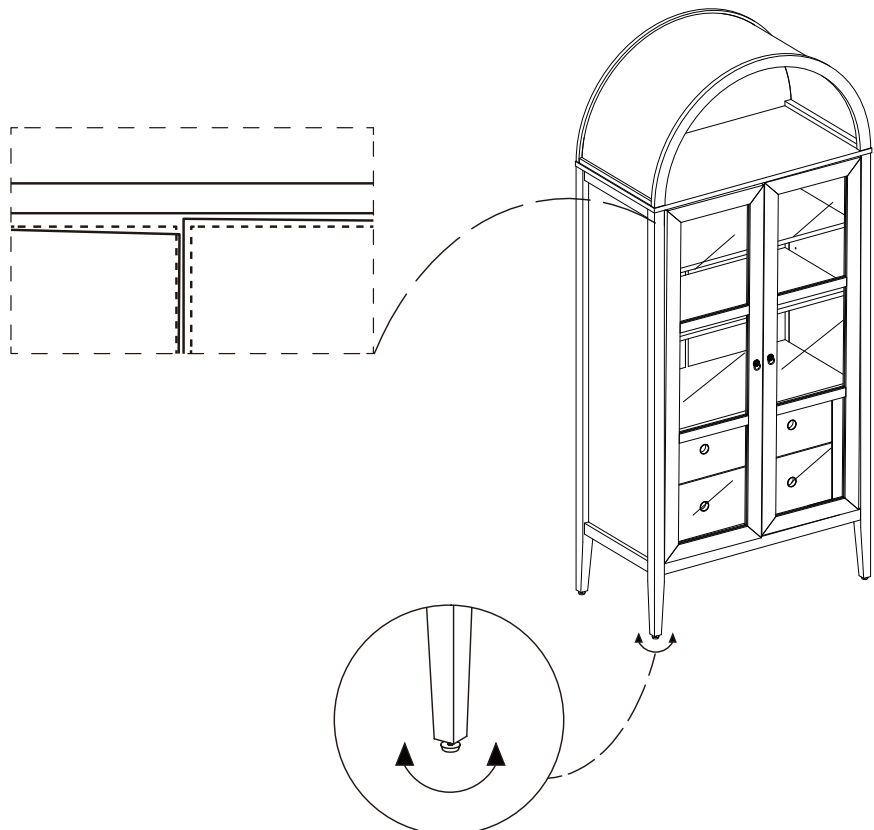

# Assembly Instructions

## Step 29

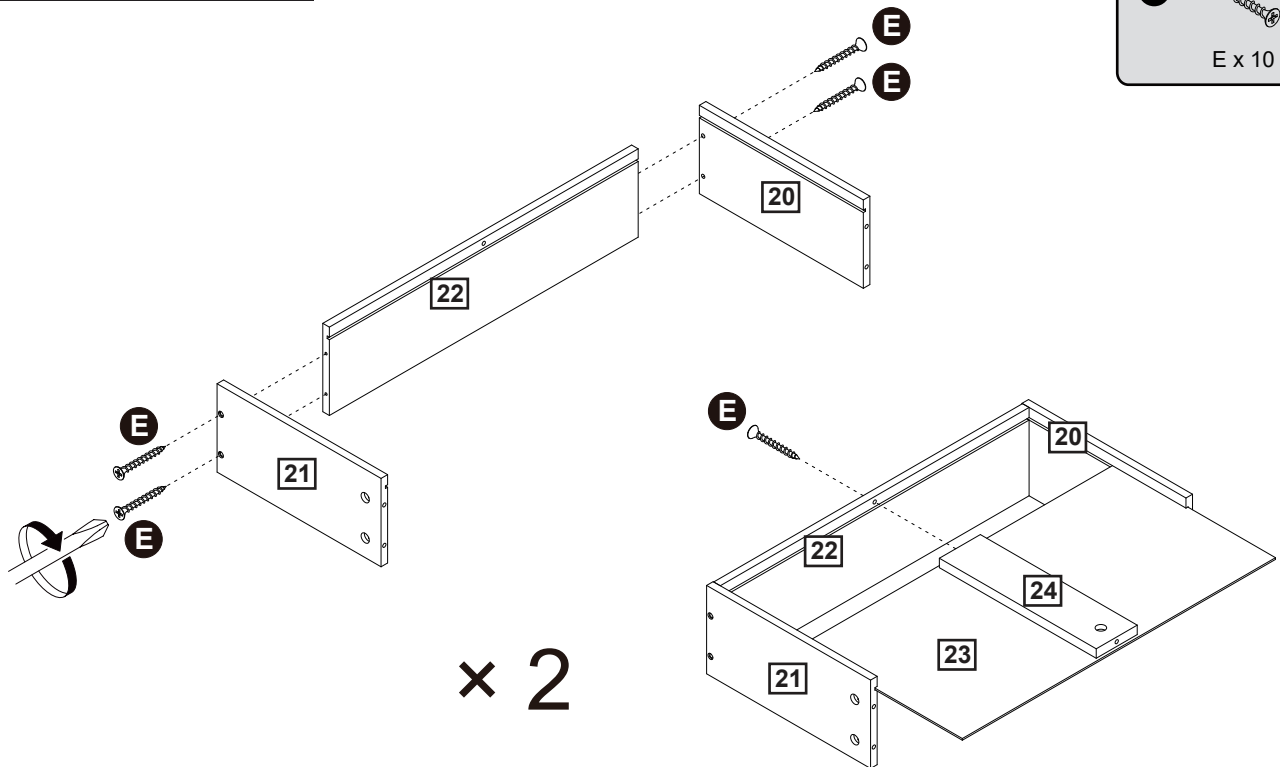

Attach part (20, 21) to part (22) using screw (E) with a screwdriver.

Slide part (23) into grooves as per diagram, then secure part (24) to part (22) using screw (E).

## Step 30

### CAM-LOCK

Tighten until shoulder is flush with panel. Do not overtighten or undertighten (see example below)

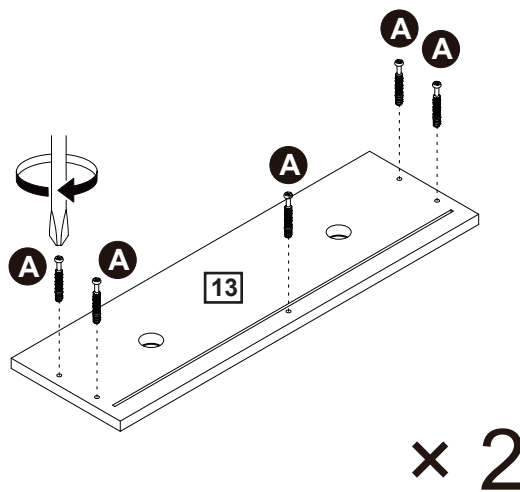
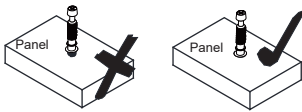
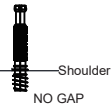

Attach cam bolt (A) to part (13) with a screwdriver.

# Assembly Instructions

## Step 31

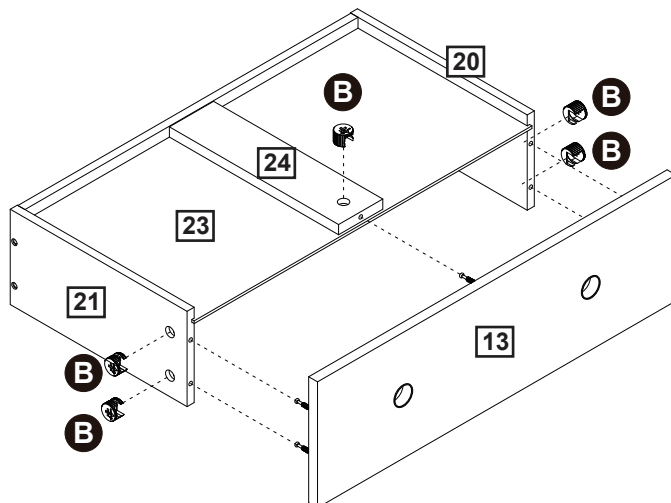

× 2

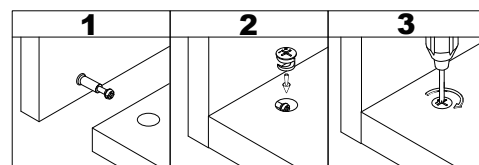

Attach part (13) to part (20, 21, 24), then insert and secure cam lock (B) to part (20, 21, 24) to lock it.

## Step 32

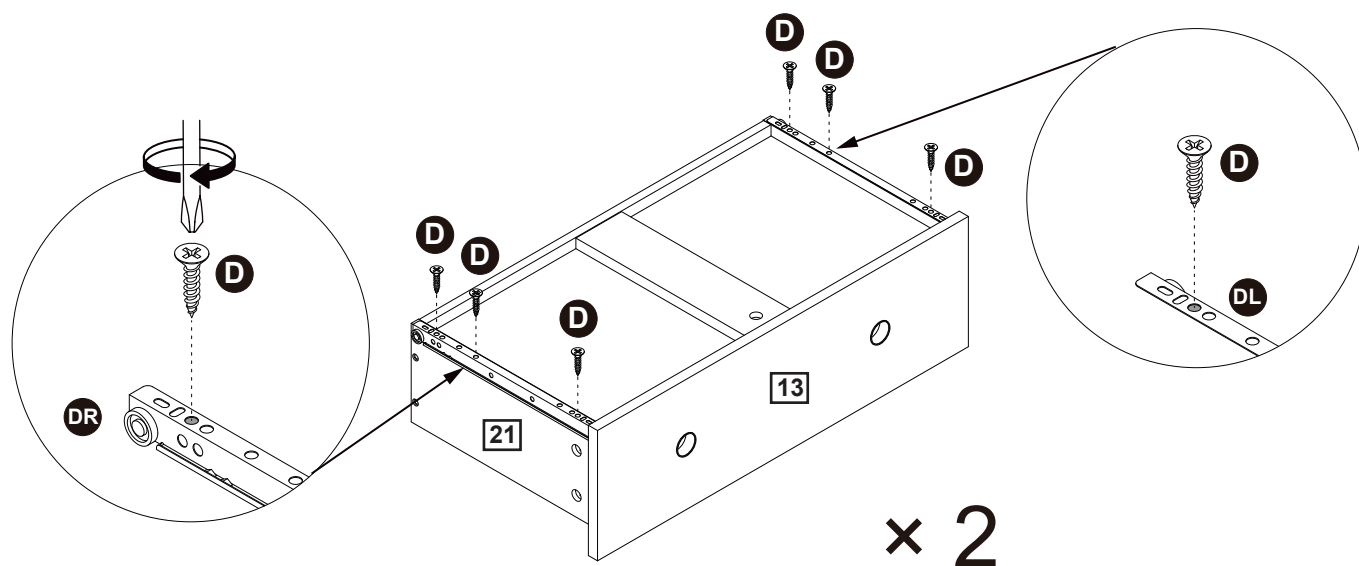
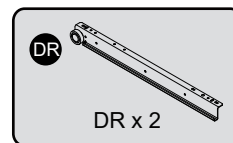
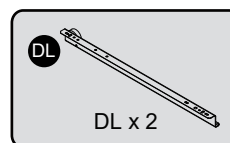
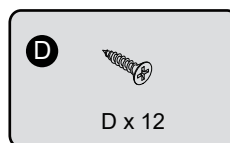

× 2

Use screw (D) to secure slide runner (DL, DR) to part (20, 21) with a screwdriver.

# Assembly Instructions

## Step 33

Congratulation! You've made to the last step! But don't be too thrilled yet, put on the drawer can be frustrating if you do it wrong. So, take your time and follow the steps below.

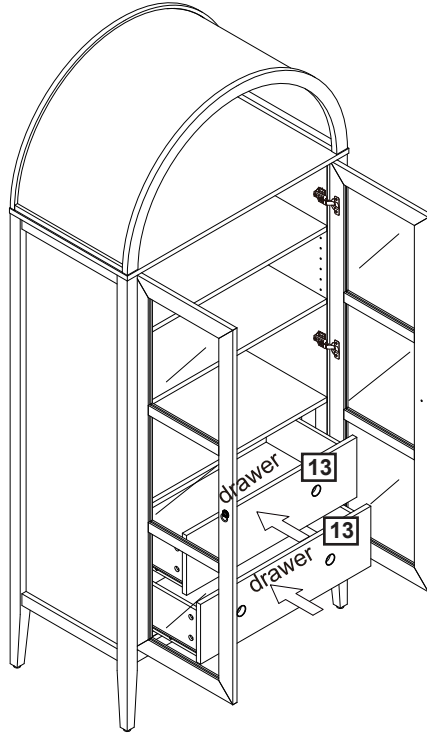

1. Please ensure that you have matched the wheels on BOTH sides of the drawer with the wheels on rails installed BEFORE push in the drawer.

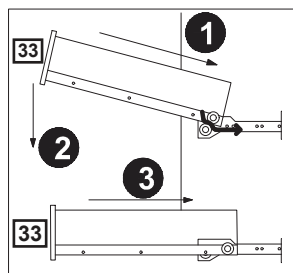

2. If the following occurs, redo the last step.

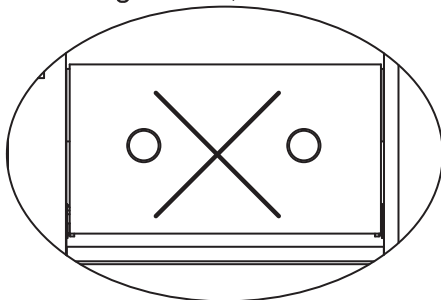

(both wheels are off the rails)

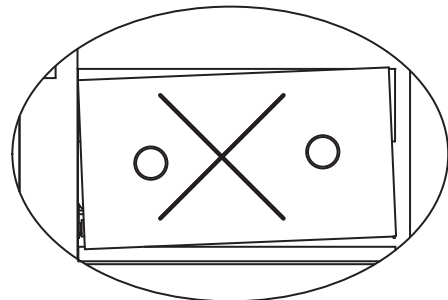

(one wheel is off the rail)

# Assembly Instructions

## Step 34

### TIPPING RESTRAINTS KIT INSTALLATION GUIDANCE

Different wall materials require unique wall fasteners.

The wall plugs (O5) and screws (O4) are designed for fixing to concrete walls only.

Please consult your local hardware store to ensure you are using the correct hardware for you wall type.

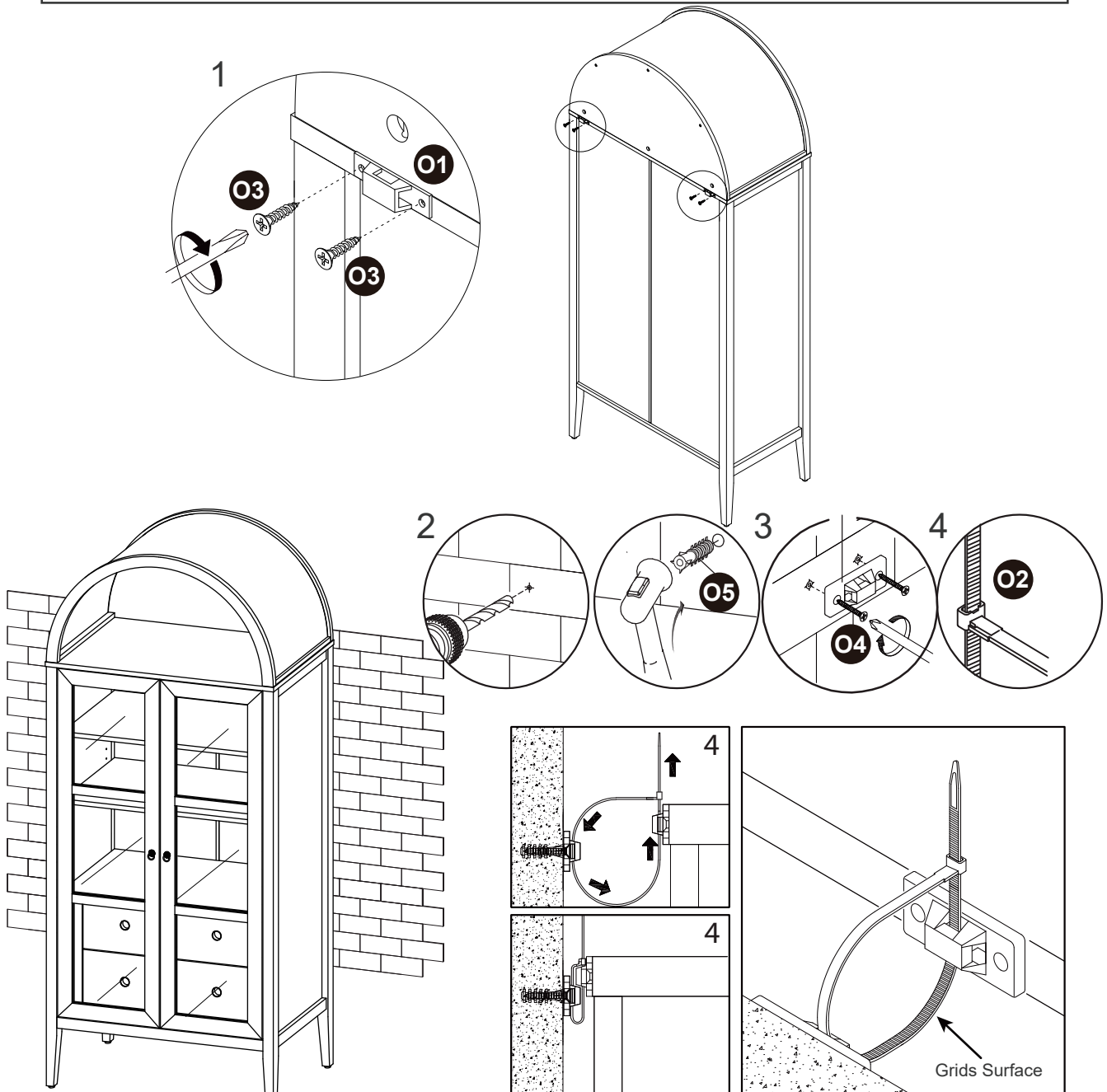
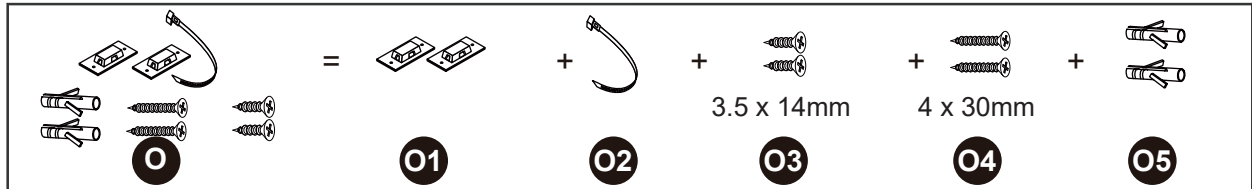
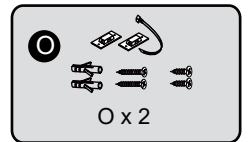

### Installation Instructions :

1. Attach bracket (O1) securely to the back top of the furniture using screw (O3) provided. Allow 8 - 10 cm from each side.
2. Please make a hole for wall plugs position on the wall and minimum 15 mm below bracket secured to the back of unit attach the wall plugs (O5).
3. Locate the other bracket (O1) on the wall over wall plugs (O5). Place furniture into position so both brackets (O1) are vertically in the line.
4. Lace the end of the restraints strap through the larger hole in each bracket. Ensure the restraints strap with grids surface facing the inner loops. Bring both ends together and slide the flat end through the locking end and draw it through until all slack is removed.
5. Make sure that the strap is securely laced & locked.

# A Guide to Wall Mounting & Fixings

## Important note:

If plastic wall plugs (rawl plugs) are supplied with your product, e.g.:



- these are only suitable for use in masonry walls.

If you are in any doubt about the correct wall plugs for your wall, seek professional advice.

Failure of the product due to using the incorrect fixings is the responsibility of the installer.



**Important:** when drilling into walls always check that there are no hidden wires or pipes etc.

Make sure that the screws and wall plugs being used are suitable for **supporting your unit**. **Consult a qualified tradesperson if you are unsure.**

Hints:

- 1: General rule:  always use a larger screw and wall plug if you are not sure.
- 2: Ensure you use the recommended drill bit to match the wall plug and hole size.
- 3: Ensure you drill the hole horizontally; do not force the drill or enlarge the hole.
- 4: Take extra care when drilling high walls, ceilings and ceramic tiles. Ensure wall plugs are inserted beyond the thickness of the ceramic tiles to avoid the tiles splitting or cracking.
- 5: Ensure wall plugs are well fitted and are a tight fit in the drilled hole.

## Types of walls

You can use one of the following types of wall plug if your walls are made of brick, breeze block, concrete, stone or wood.

No.1 "General Purpose" wall plug

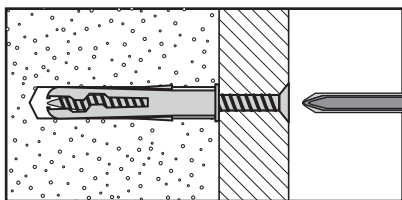

Generally aerated blocks should not be used to support heavy loads, use a specialist fitting in this case. For light loads, general purpose wall plugs can be used.

No.3 "Cavity Fixing" wall plug

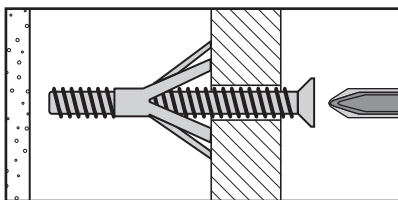

For use with plasterboard partitions or hollow wooden doors.

No.5 "Hammer Fixing" wall plug

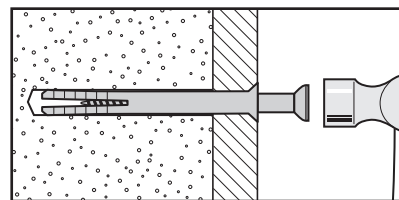

For use with walls stuck with plasterboard. The hammer fixing allows it to be fixed to the wall rather than the plasterboard. Always check the fixing is secure to the retaining wall.

No.2 "Plasterboard" wall plug

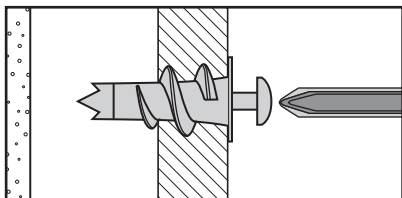

For use when attaching light loads onto plasterboard partitions.

No.4 "Cavity Fixing - Heavy Duty" wall plug

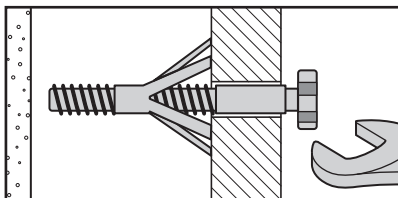

For use when fitting or supporting heavy loads such as shelving, wall cabinets and coat racks.

No.6 "Shield Anchor" wall plug - heavy loads

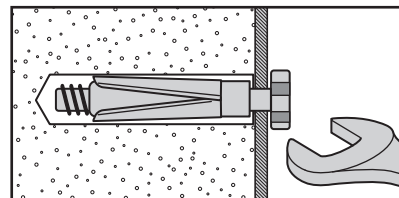

For use with heavier loads such as TV and HiFi speakers and satellite dishes etc.



## Care & Maintenance

**Safety:** always check the fitting and location to ensure your safety in and around the home.

**Fitting:** from time to time check the fitting to ensure the wall plugs or screws do not become loose.