

# ASSEMBLY INSTRUCTIONS

Please read the instructions carefully to ensure safe operation of the product.

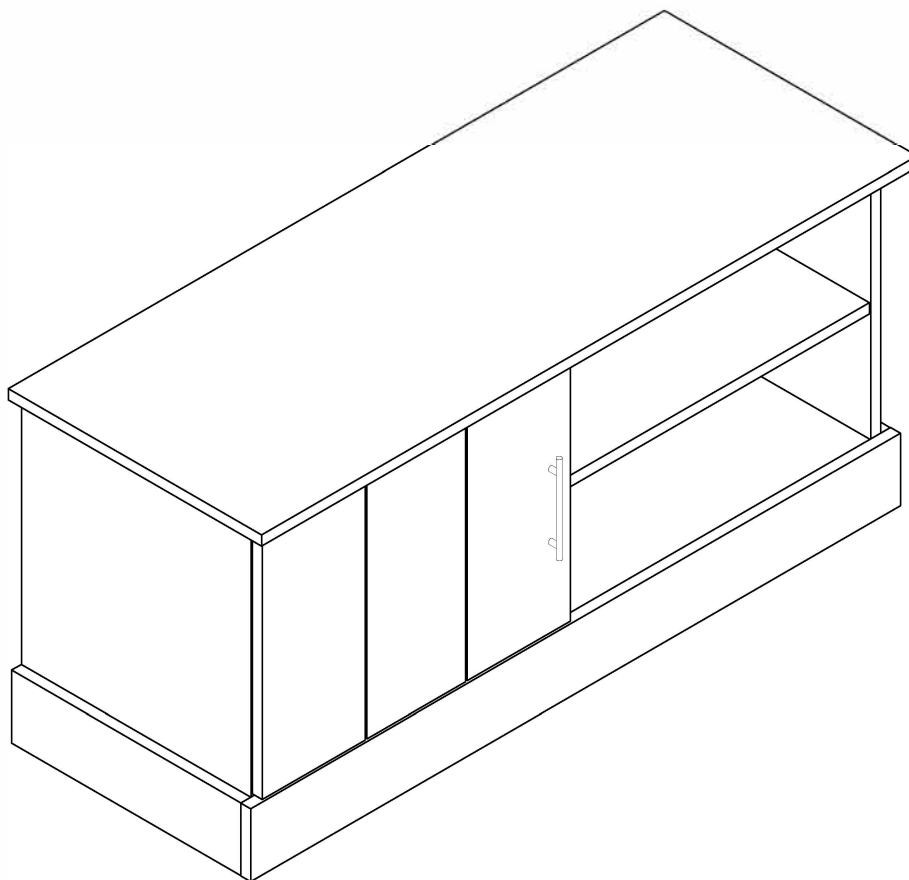

Size: 1000 x 390 x 475mm

---

**PLEASE READ** this sheet prior to assembly to familiarise yourself with the various stages of construction.

Carefully open the pack supplied and check the contents against the parts and fittings check list. Do not destroy any of the packaging until you are certain that you have all the necessary parts for the assembly.

**CAUTION:** There are small components used in the construction of this unit. These loose items should be kept away from young children whilst assembling your unit to avoid the danger of choking hazards.

---

## Tools Required

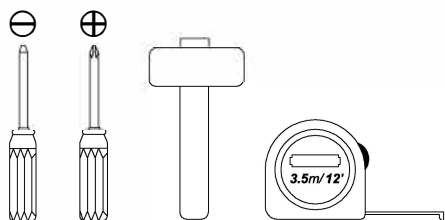

## Person Required

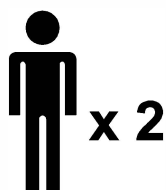

## Approximate Assembly Time



## **IMPORTANT - READ CAREFULLY - RETAIN THESE INSTRUCTIONS FOR FUTURE REFERENCE.**

### **INFORMATION**

- Due to the size of this product we recommend that it is assembled in the room intended for use.
- When you are ready to start, make sure that you have the right tools, plenty of space and a clean, dry area for assembly.
- Unwrap all packaging materials and place the components on top of the carton box or on a clean floor to prevent it from scratching.
- Check the pack and make sure you have all the parts listed.
- Ensure that this product is fully assembled as illustrated before use.
- Check all screws or bolts are tightened and inspect regularly
- This product should only be used on firm, level ground.
- Keep small parts out of reach of children.
- Make sure the legs remain in contact with the ground.
- Tools not included.

### **WARNINGS**

- DO NOT use power tools to construct this product.
- DO NOT over tighten screws or bolts.
- DO NOT use this product if parts are missing, damaged or worn.
- DO NOT sit or stand on the product.

### **CARE INFORMATION**

- Never use scourers, abrasives or chemical cleaners.
- To clean wipe with a sponge and warm soapy water. Do not use solvent based cleaners or detergents as they can bleach or damage the product.

Please check the pack contents before assembling the product. If any components are missing, please contact your retailer. The fittings pack contains small items that should be kept away from small children.

## Parts

CODE	PART NAME	QTY	DIMENSION
A	Side Panel - L	1	15 x 350 x 440mm
B	Side Panel - R	1	15 x 350 x 440mm
C	Top Panel	1	30 x 386 x 1000mm
D	Bottom Panel	1	15 x 350 x 930mm
E	Center Panel	1	15 x 350 x 345mm

CODE	PART NAME	QTY	DIMENSION
F	Fix Panel	1	15 x 325 x 471mm
G	Bottom Support	1	15 x 80 x 930mm
H	Front Profile	1	15 x 96 x 991mm
I	Door	1	15 x 337 x 470mm
	Back Panel	1	3 x 386 x 956mm

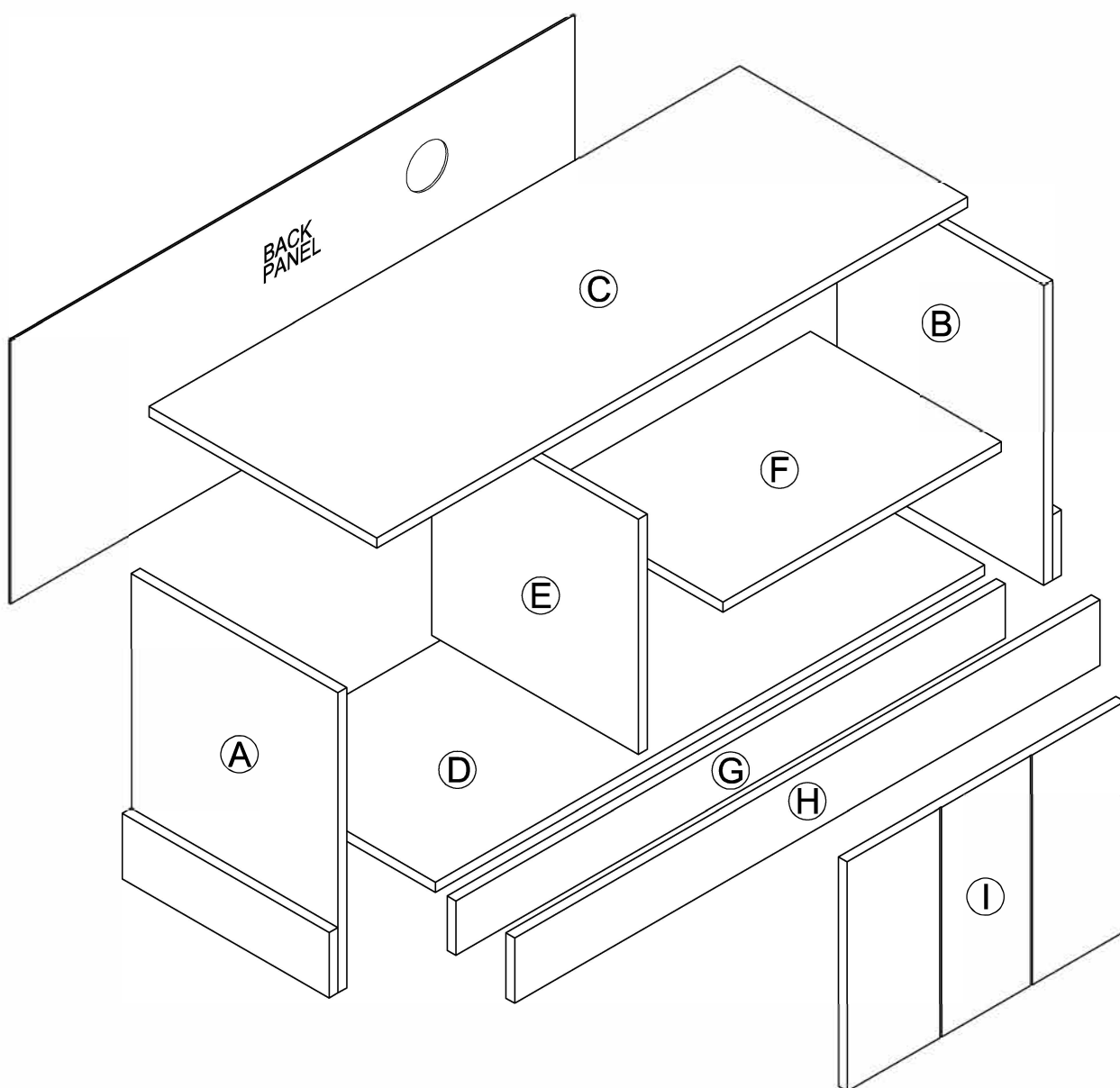

## Fixings (to scale)

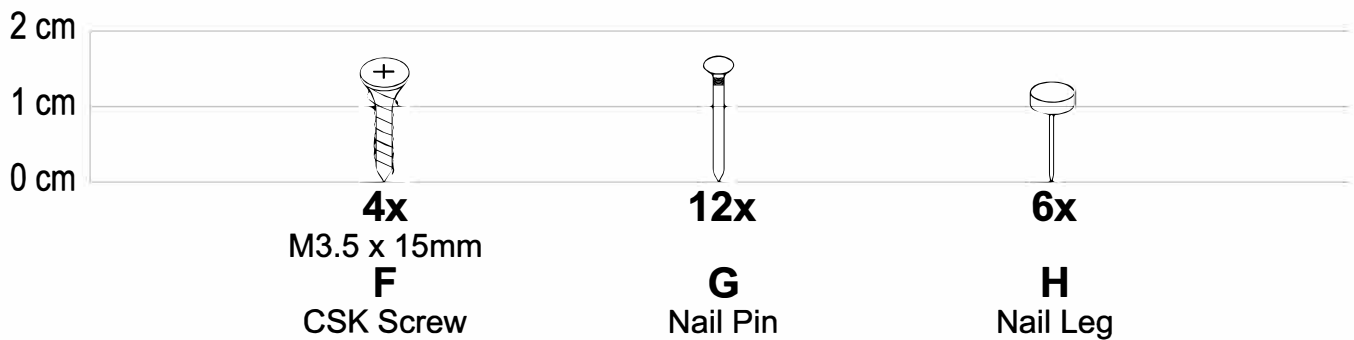
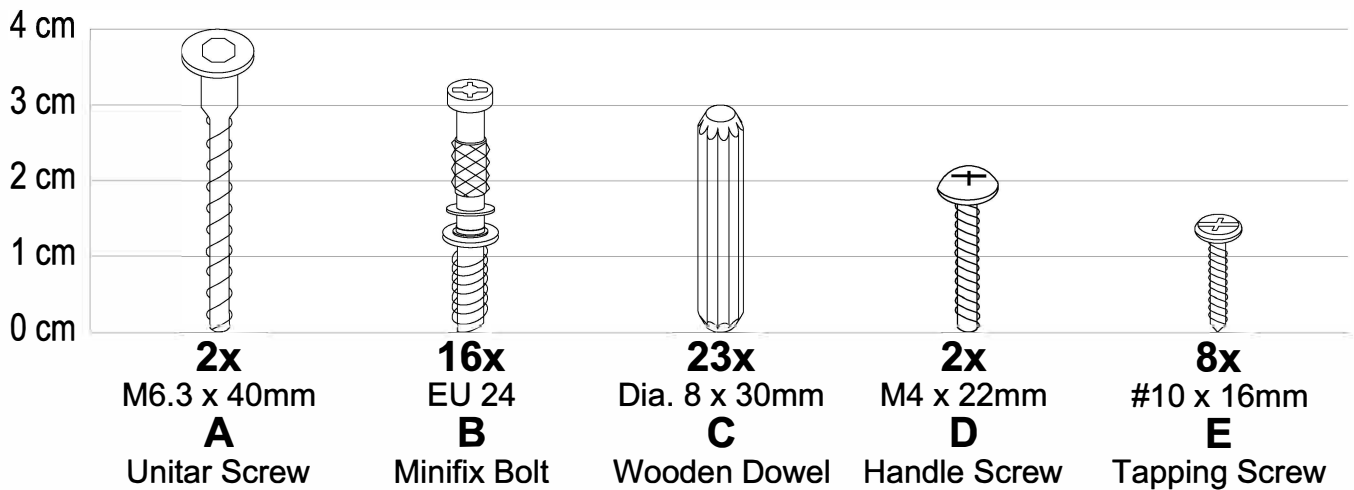

## Fixings (not to scale)

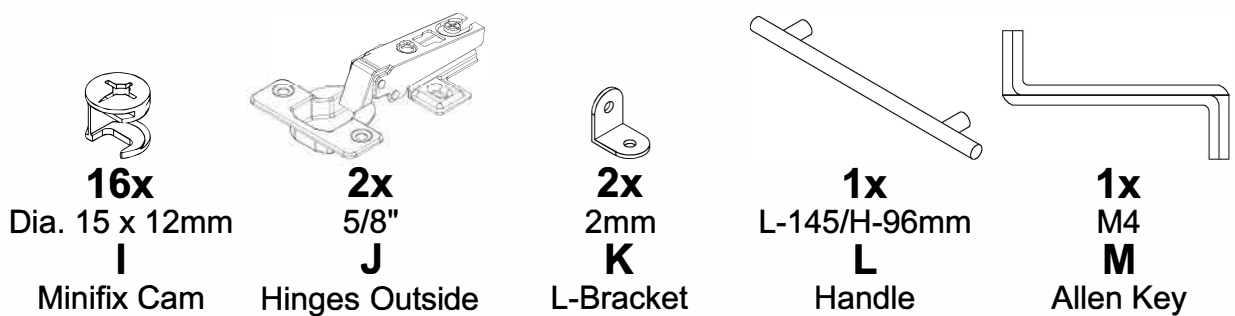

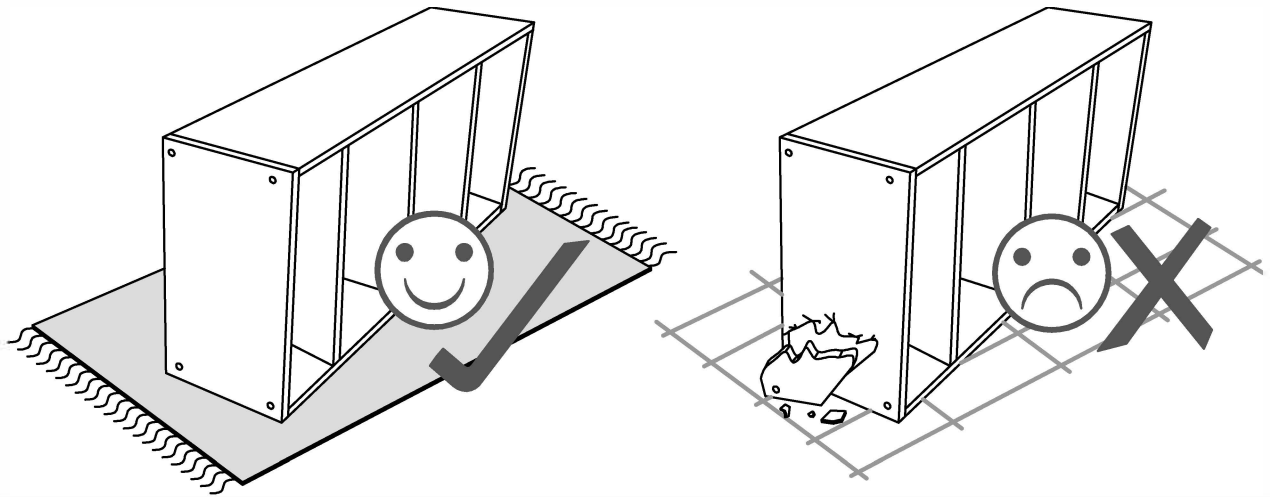

### Layout Parts on Soft Surface

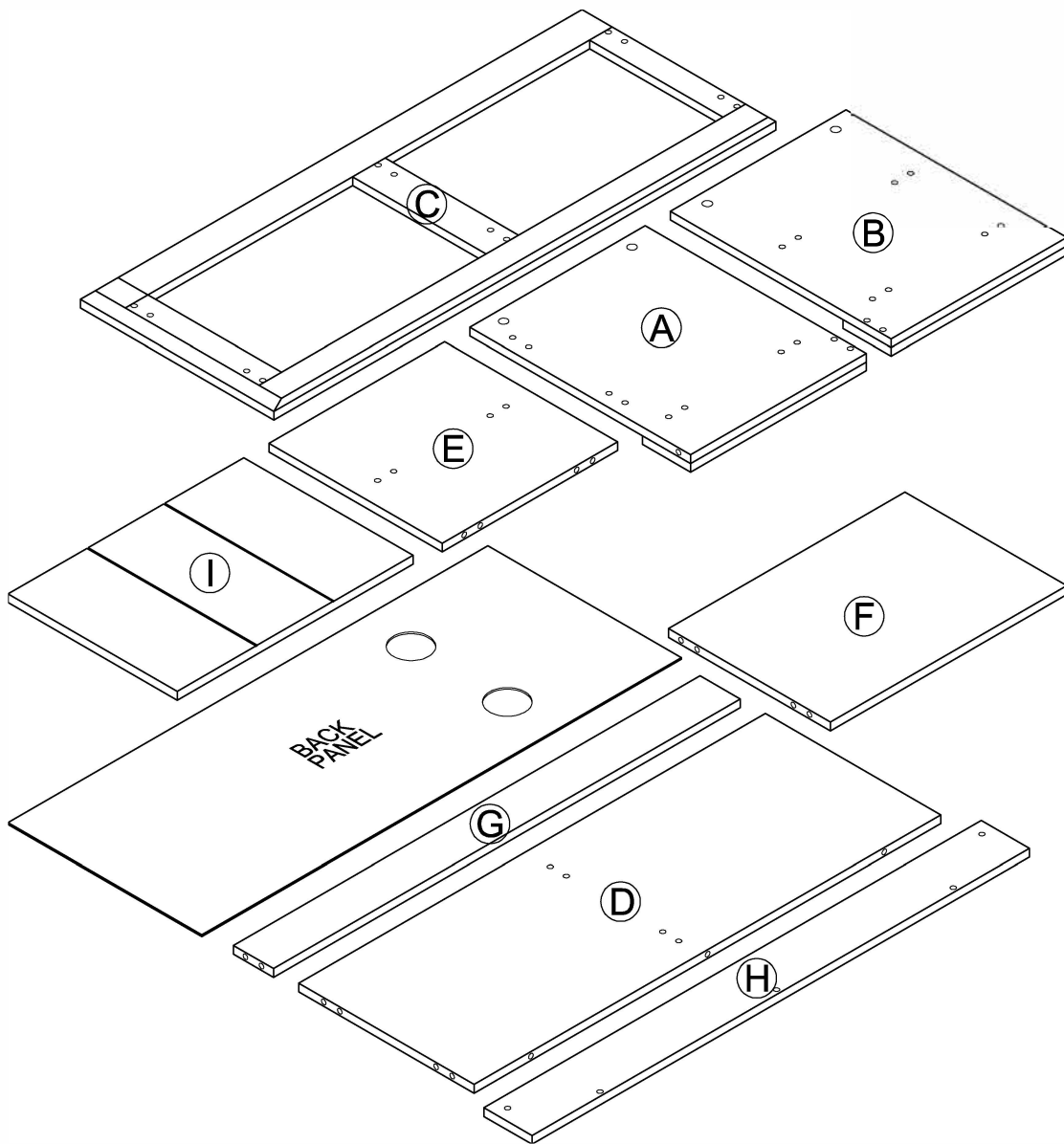

# STEP 1

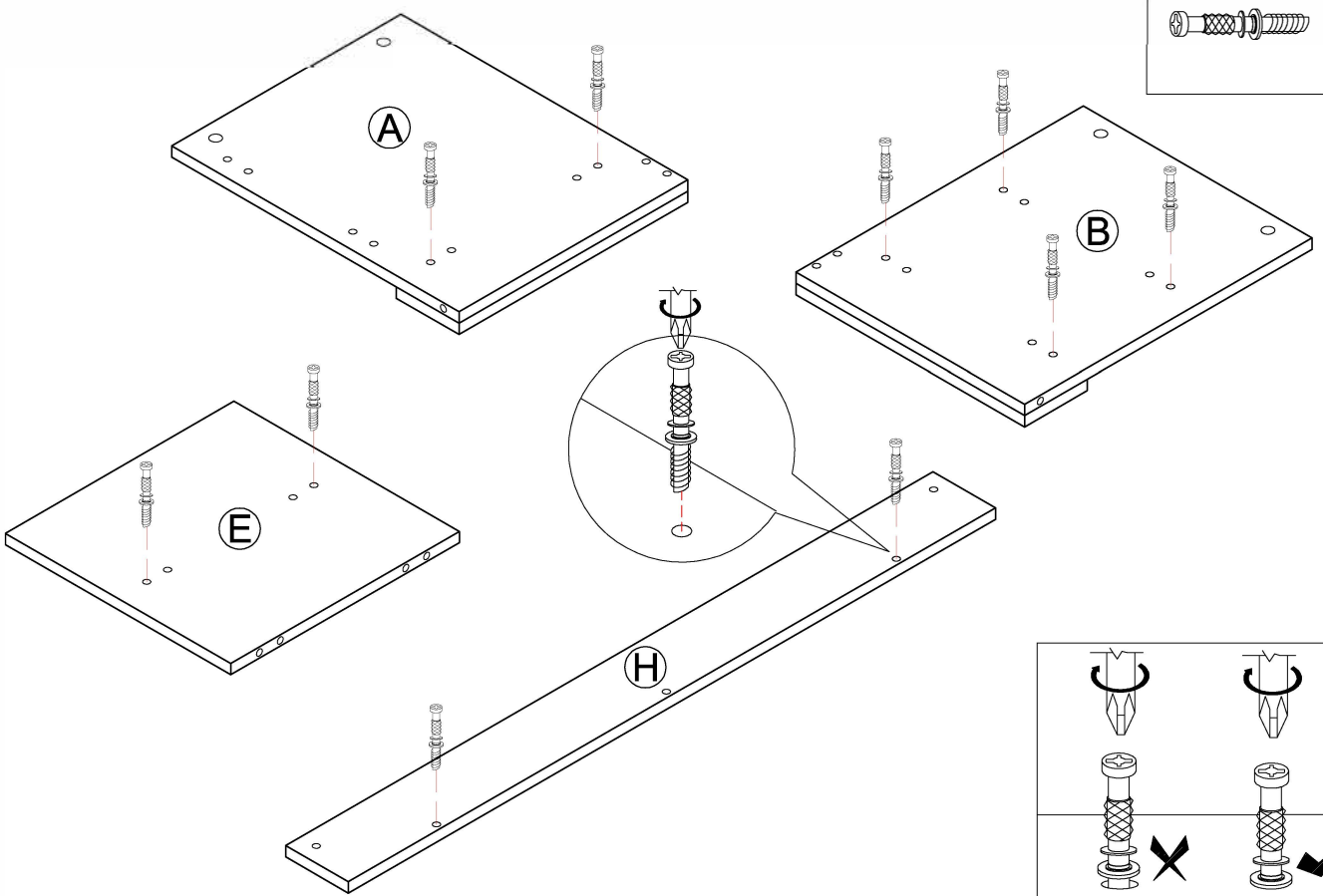
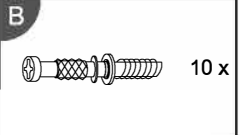

# STEP 2

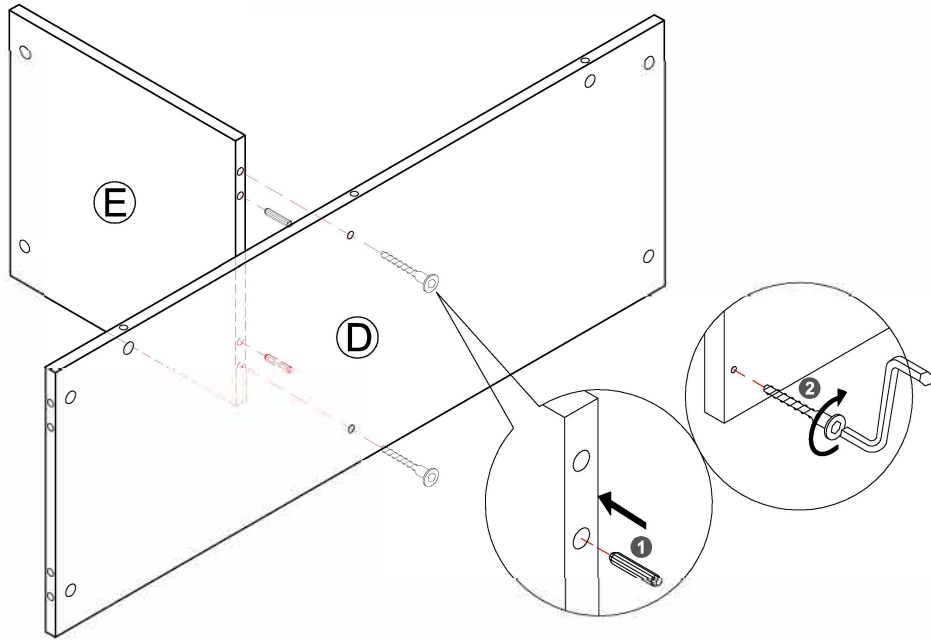
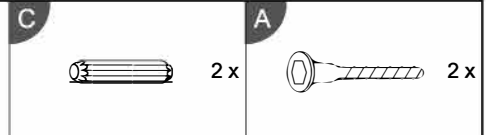

### STEP 3

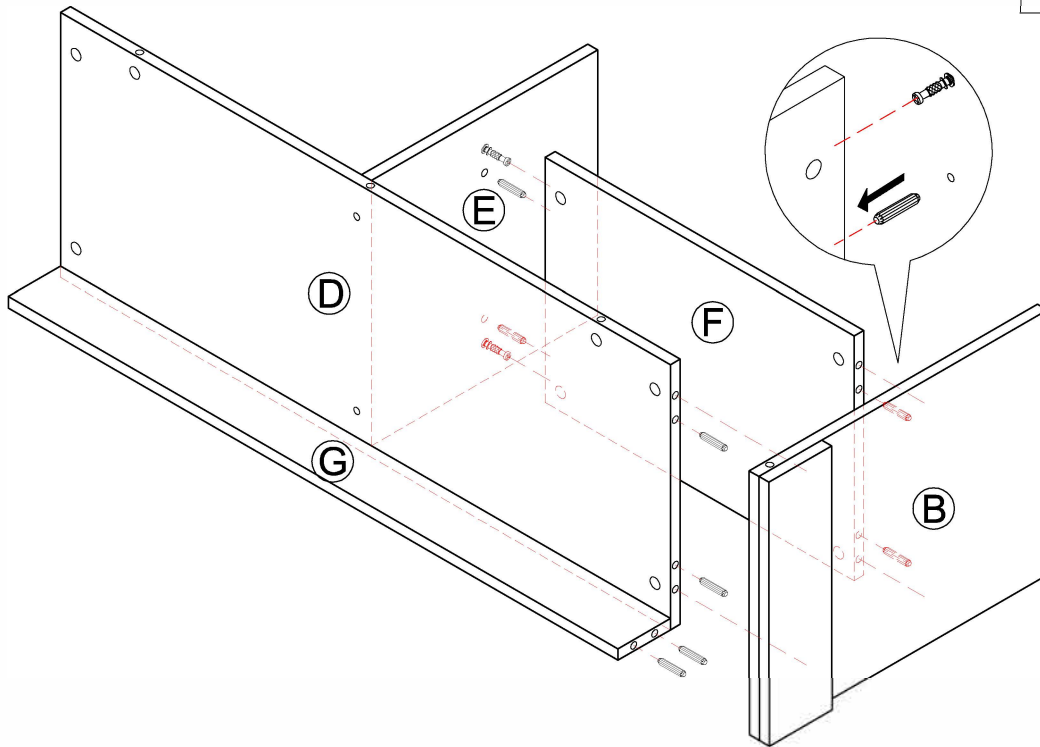

### STEP 4

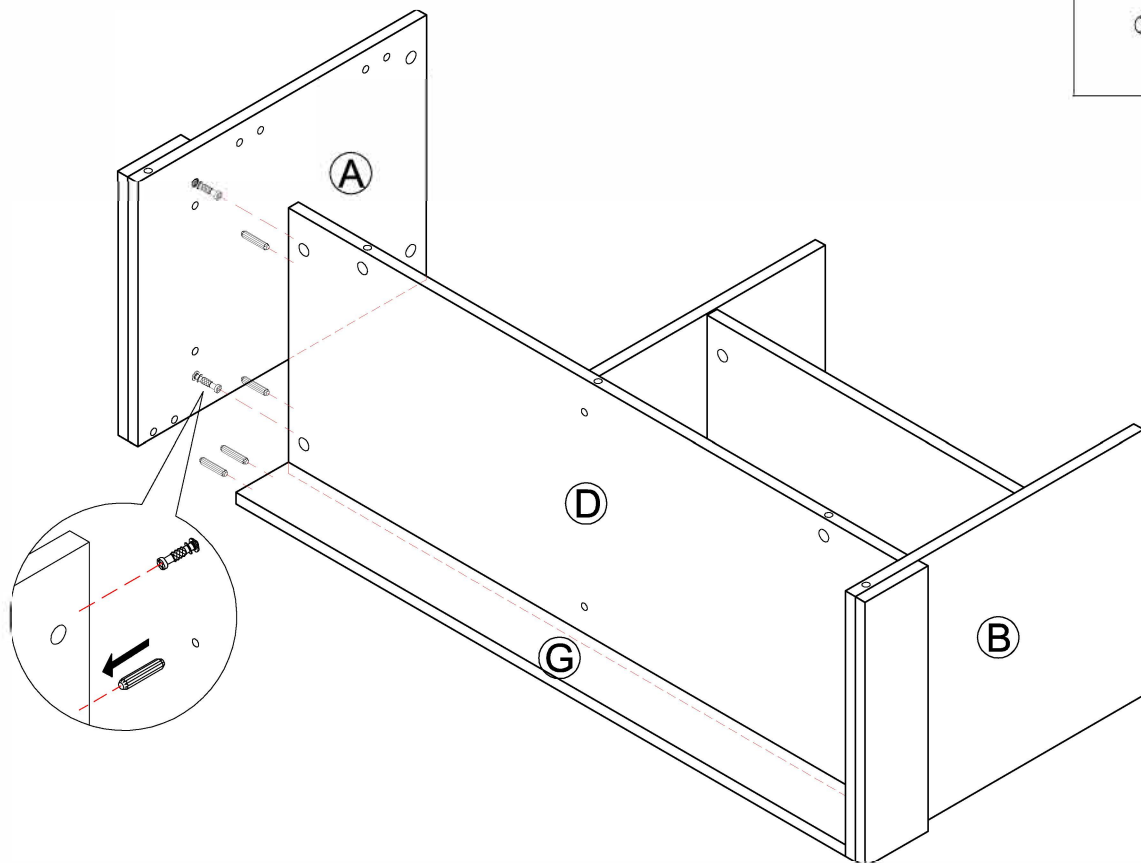

# STEP 5

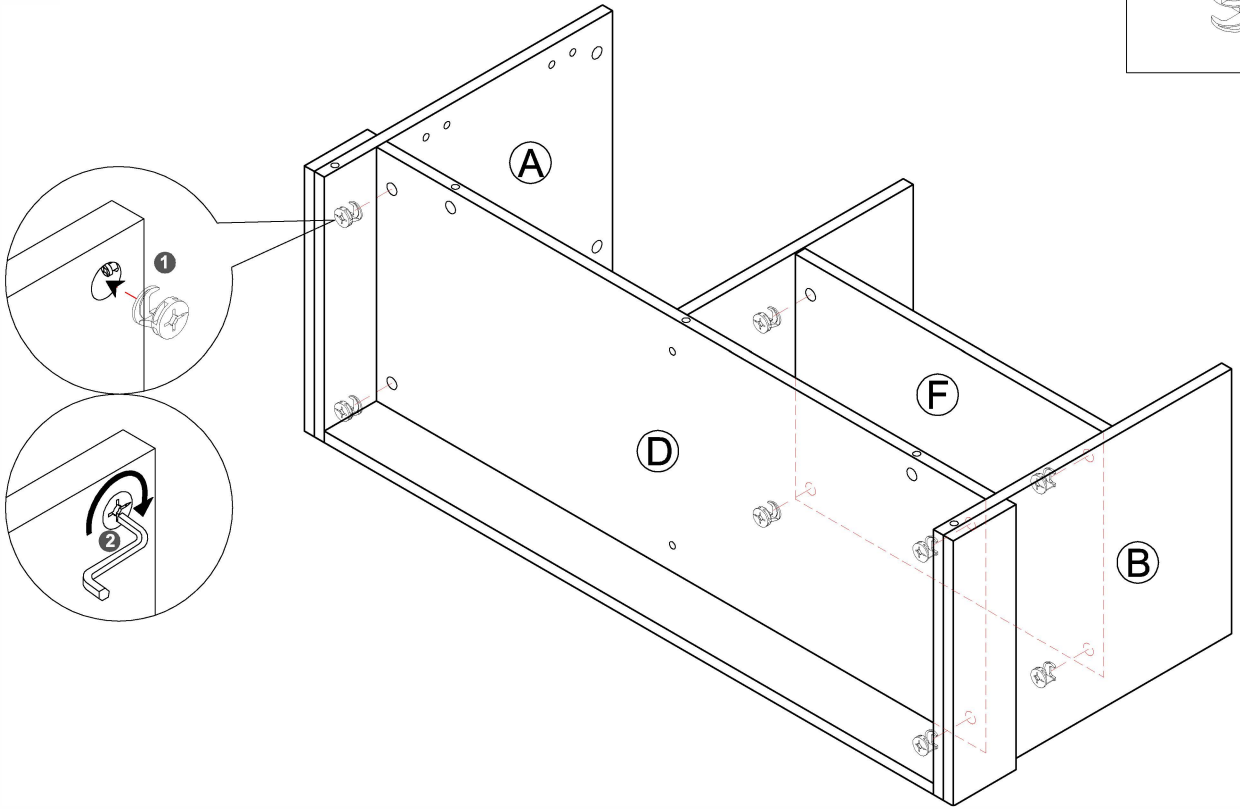
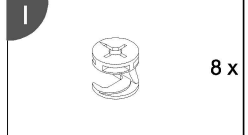

# STEP 6

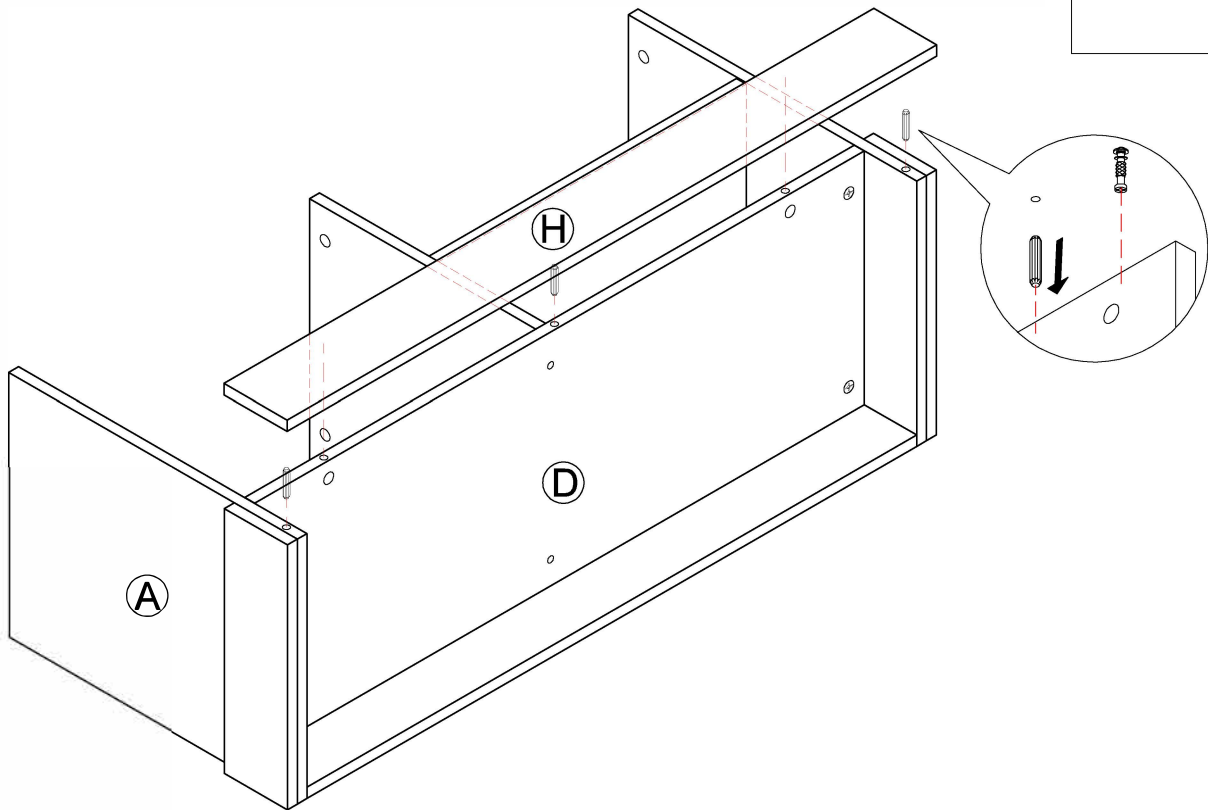
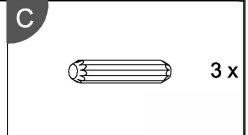

# STEP 7

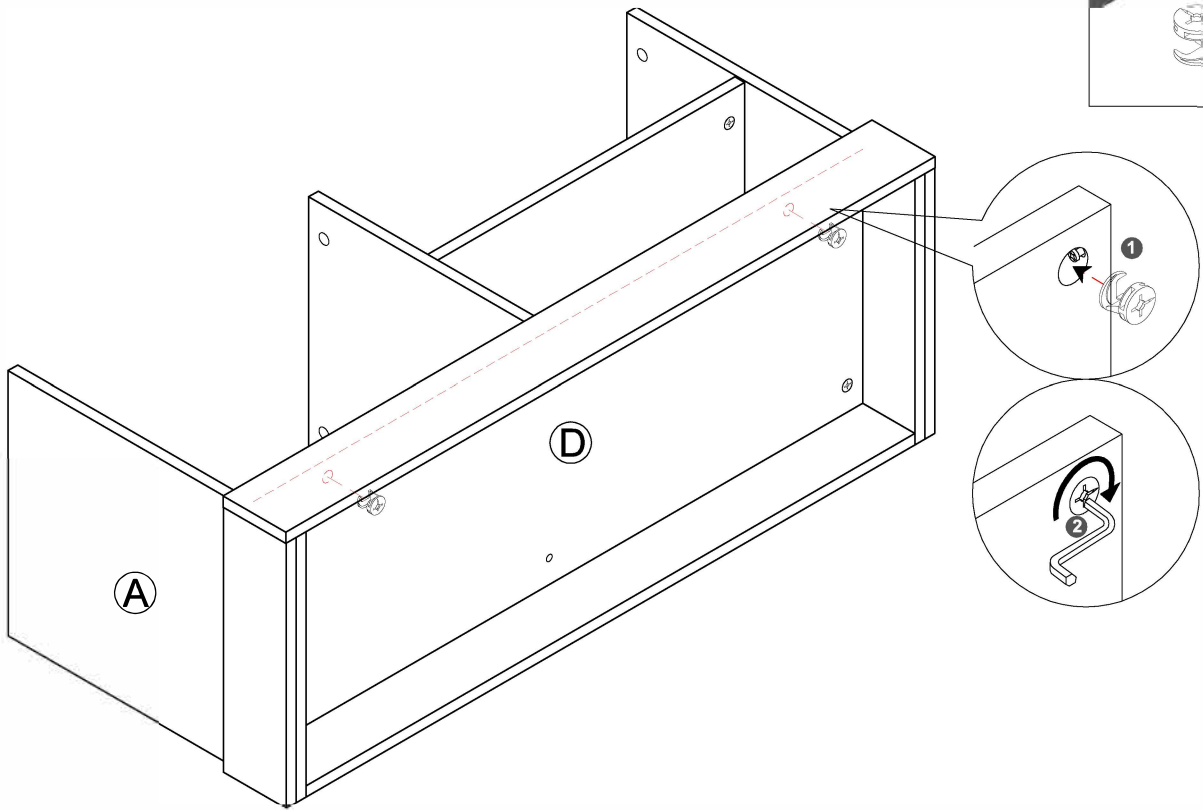

# STEP 8

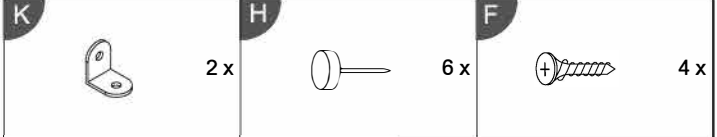
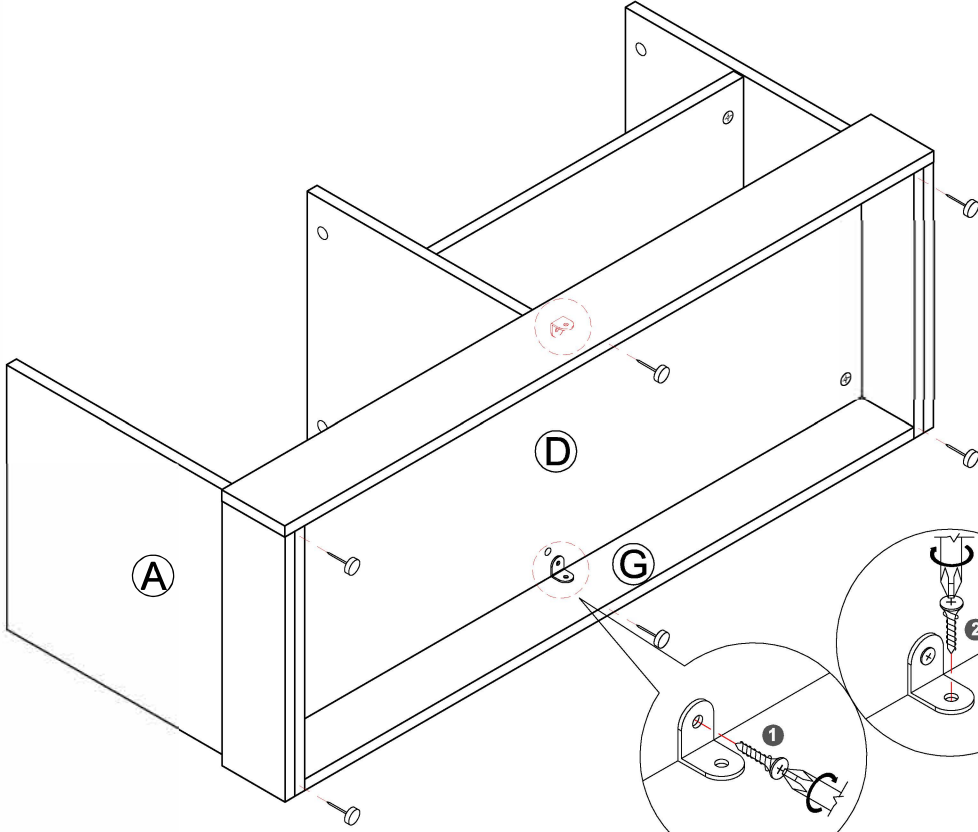

**WARNING : THE FRONT NAIL LEG MUST FIX AT 10MM FROM FRONT.**

**STEP 9**

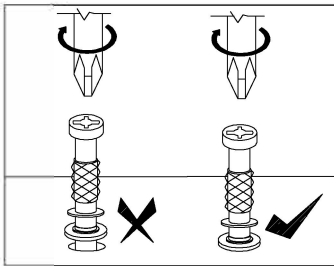
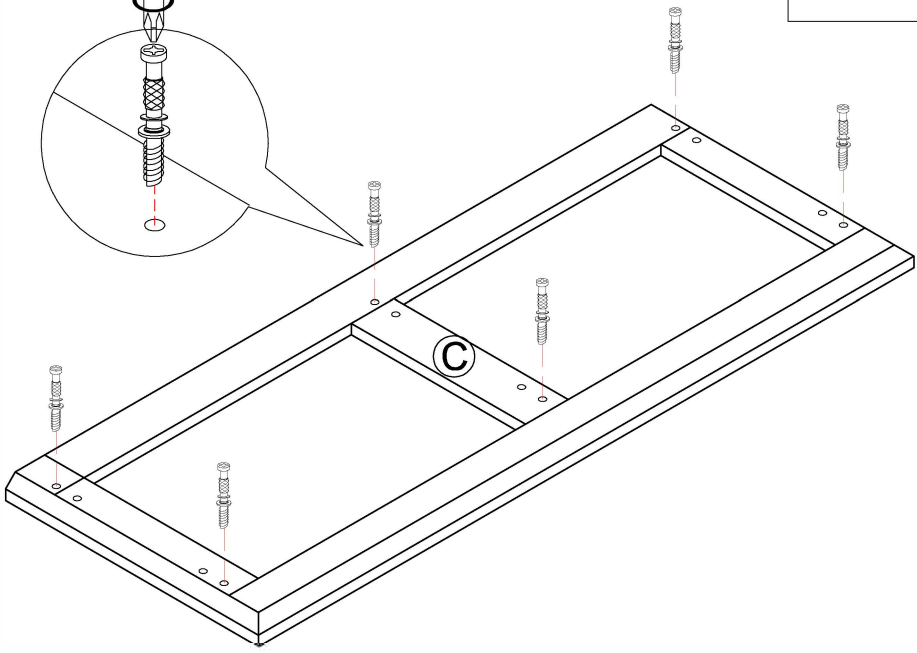
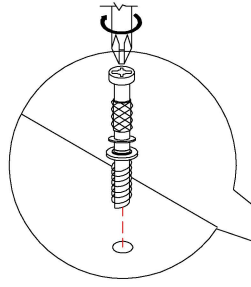
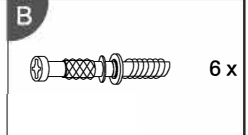

**STEP 10**

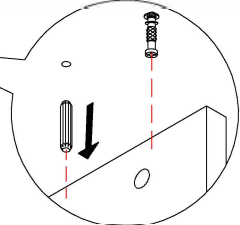
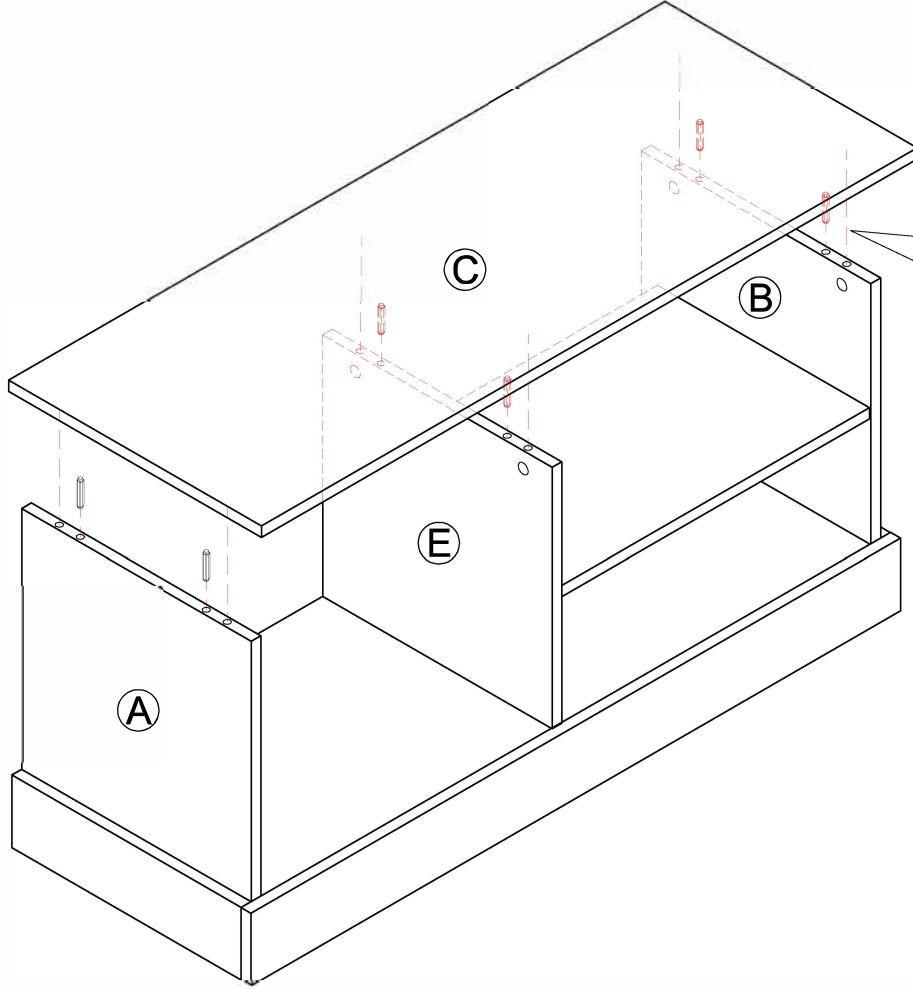

# STEP 11

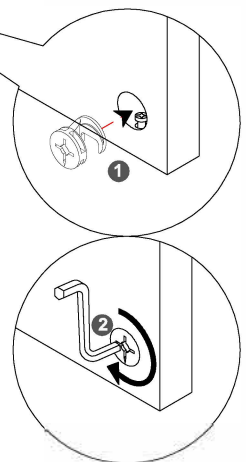
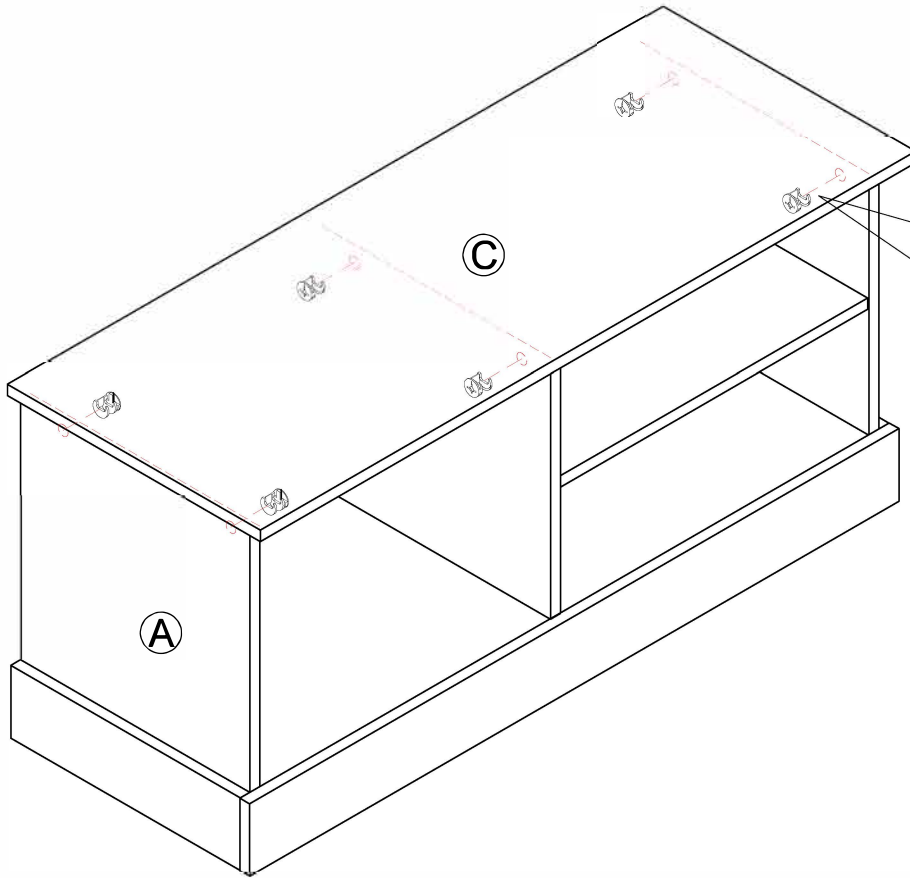

# STEP 12

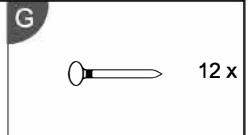
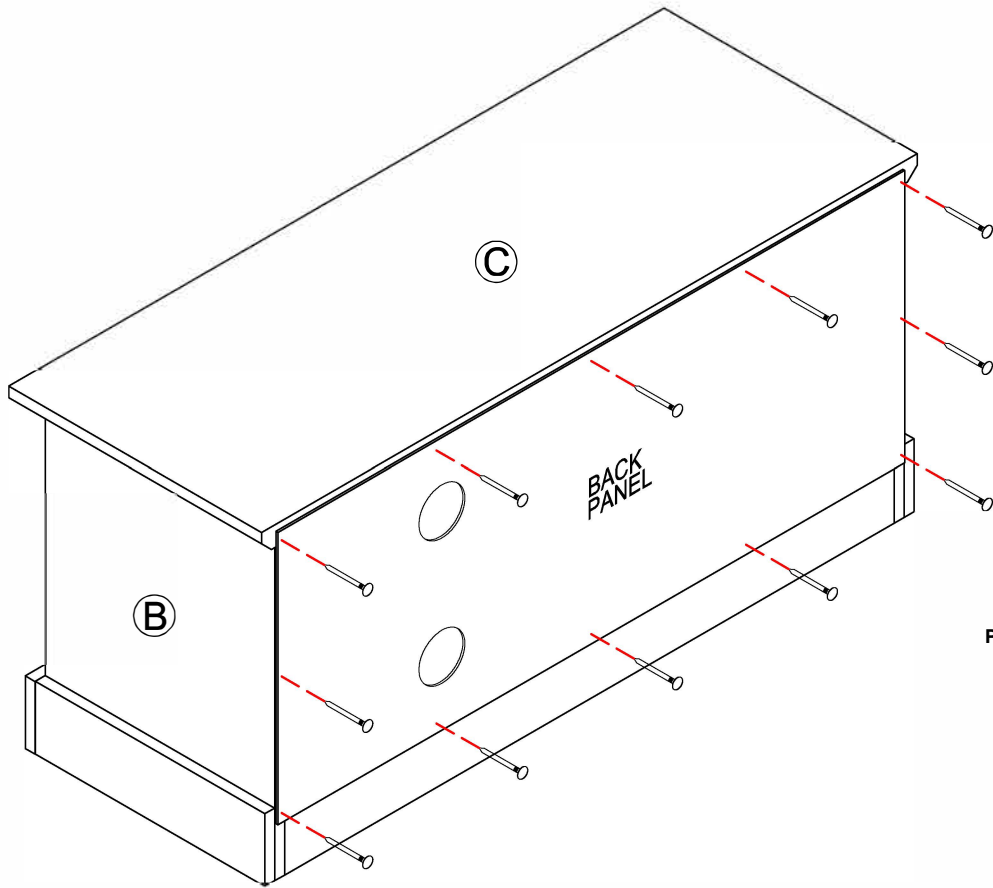

PLEASE ENSURE THAT EACH OF THE FOUR CORNERS OF THE CABINET IS SQUARE.

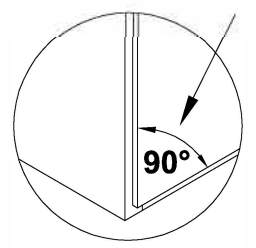

# STEP 13

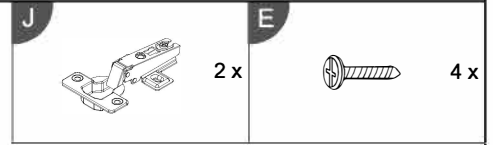
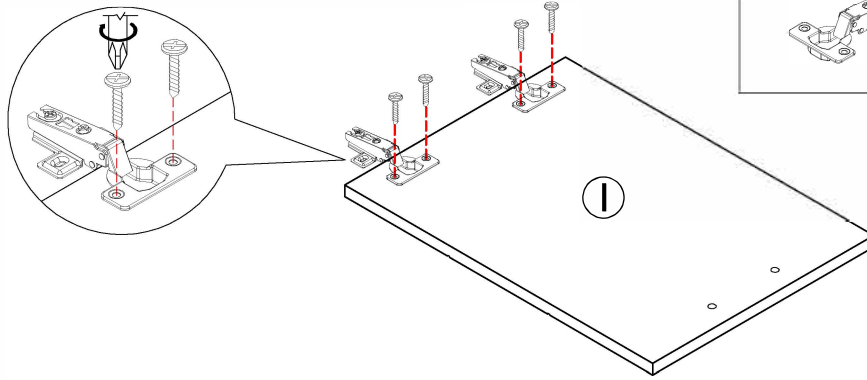

# STEP 14

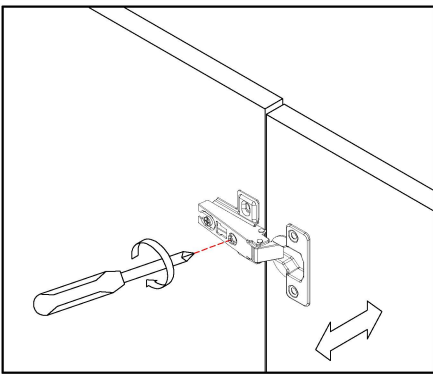
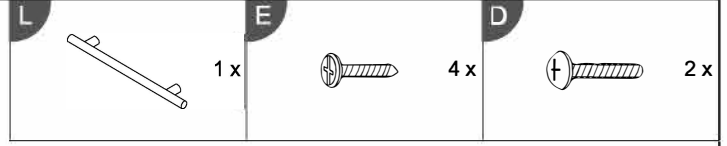
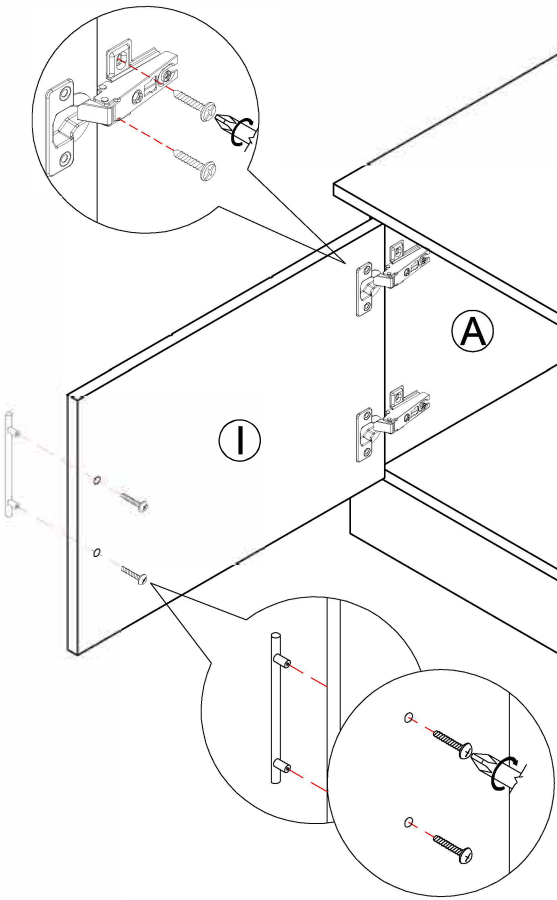

**A.** Lateral adjustment by screw adjusting

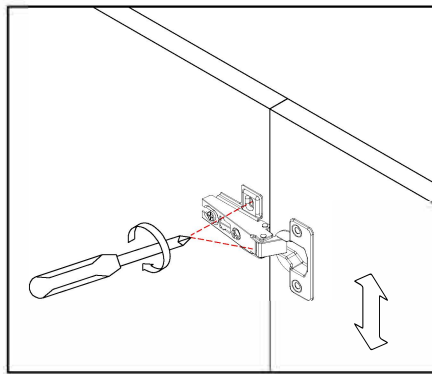

**B.** Vertical adjustment via slot in the mounting plate

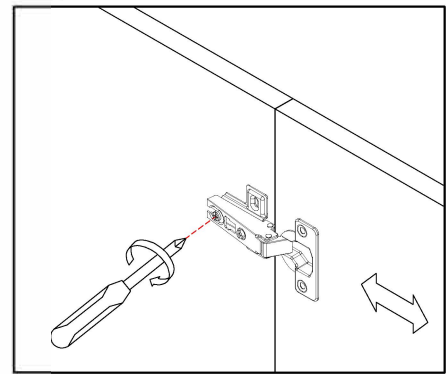

**C.** Front-to-Back by the slacking the hinge arm mounting screw

## Complete Assembly

Periodically check to ensure that the components are in their proper position, free from damage. Also, make sure the connectors are tight and secure.

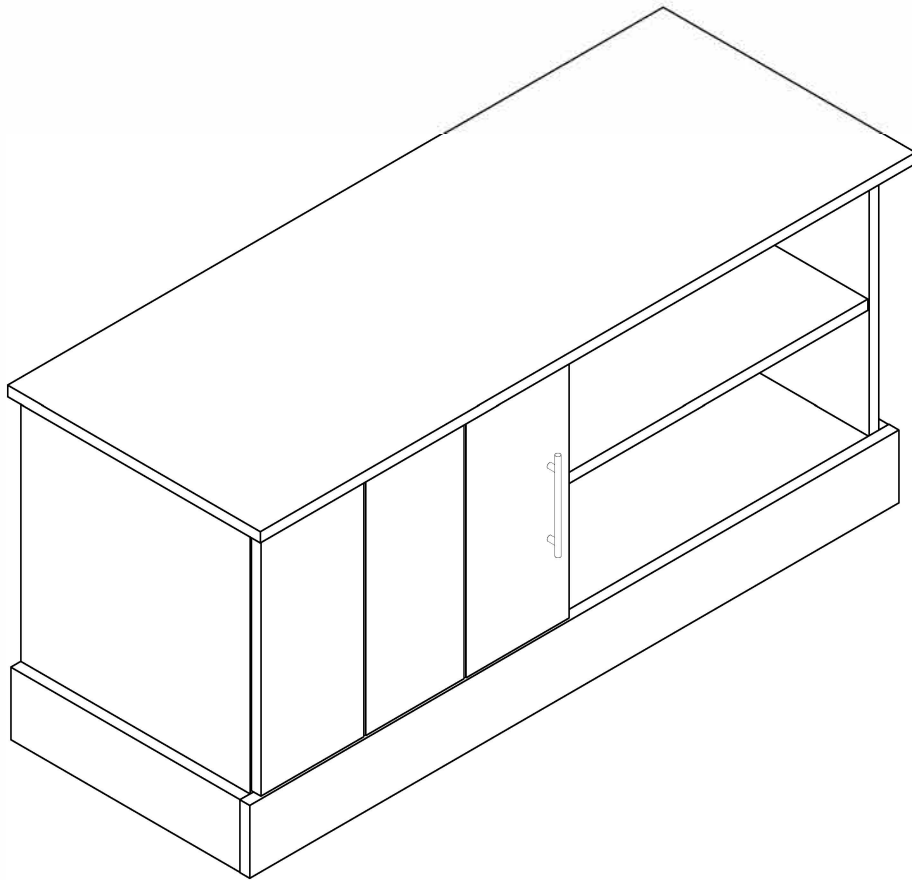

**Keep instructions for future reference**

