



FREESTANDING GAS RANGE



INSTALLATION GUIDE

SPECIFICATIONS, INSTALLATION, AND MORE

MODEL NUMBERS:

			
FFSGS6260-30	FFSGS6260-36	FFSGS6260-48	FFSGS6260-60

Contents

Customer Care	3
Consumer Information	4
Important Safety Information	6
Features of Your Range	10
Installation Instructions	
Door Handle Installation	12
Cooktop Burner Grates Installation	12
Oven Racks Installation	13
Electrical	13
Gas Supply	14
Pressure Regulator	15
Gas Shut-off Valve	15
Product Dimensions and Cabinets	16
Exhaust Hood Installation	20
Gas Conversion Operation	20
Gas Supply Connection	26
Cooktop Operation	
Ignition	27
Simmer and Boil	27
Burner Grates	28
Griddle Operation	28
Cooktop Cleaning Tips	28
Oven Light	28
LED Light Switch	28
Oven Roasting	28
Oven Baking Operation	
Preheating	29
Convection Bake	29
Convection Roast	30
Broiler Operation	
Setting Broil	30
Oven Cleaning Tips	31
Oven Thermostat & Cooking Time	31
Care and Cleaning Recommendation	31
Troubleshooting Tips	32
Please Read Before Using Your Oven	34
Wire Diagram	35

Customer Care

Thank you for purchasing a **FORNO** product. Please read the entire instruction manual before operating your new appliance for the first time. Whether you are an occasional user or an expert, it will be beneficial to familiarize yourself with the safety practices, features, operation and care recommendations of your appliance.

Both the model and serial number are listed inside the product. For warranty purposes, you will also need the serial number, the date of purchase & a copy of your proof of purchase. Record this information below for future reference.

SERVICE INFORMATION

Use these number in any correspondance or service calls concerning your product.

Model Number

If you received a damaged product, immediately contact **FORNO**.

Serial Number

Save time and money. Before you call for service, check the Troubleshooting Guide. It lists the causes of minor operating problems that you can correct yourself.

Date of Purchase

Purchase Address & Phone

SERVICE IN CANADA & UNITED STATES

Keep the instruction manual handy to answer your questions. You can also find all the information you need online at www.fornoappliances.com.

If you don't understand something or you need more assistance, please visit our website or call our Customer service: 1 866-231-8893 opt.2 ext.214

Or email : mysupport@forno.ca

If there is a problem, please contact FORNO customer service. All warranty work needs to be authorized by FORNO customer service. All of our authorized service providers are carefully selected and rigorously trained by us.

Consumer Information

Range Safety

Your safety and the safety of others are very important.

We have provided many important safety messages in this manual and on your appliance. Always read and obey all safety messages.



This is a safety alert symbol. It will alert you to potential personal or property safety hazards. Obey all safety messages to avoid any property damage, personal injury or death.

⚠ WARNING

WARNING indicates a potentially hazardous situation which, if not avoided, could result in serious injury or death.

⚠ CAUTION

CAUTION indicates a moderate hazardous situation which, if not avoided, could result in minor or moderate injury.

All safety messages will alert you what the potential hazard is, tell you how to reduce the chance of injury, and let you know what can happen if the instructions are not followed.

⚠ WARNING

If the information in this manual is not followed exactly, a fire or explosion may result, causing property damage, personal injury or death.

Do not store or use gasoline or other flammable vapors and liquids in the vicinity of this or any other appliance.

- WHAT TO DO IF YOU SMELL GAS

- Do not try to light any appliance.
- Do not touch any electrical switch.
- Do not use any phone in your building.
- Immediately call your gas supplier from a neighbor's phone. Follow the gas supplier's instructions.
- If you cannot reach your gas supplier, call the fire department.

Installation and service must be performed by a qualified installer, service agency or the gas supplier.

ANTI-TIP DEVICE



WARNING

Tip-Over Hazard

A child or adult can tip the range which can result in serious injuries or death.

Install the anti-tip device to the range and/or structure per installation instructions.

Engage the range to the Anti-tip device installed to the structure.

Re-engage the anti-tip device if the range is removed.

Failure to follow these instructions can result in death or serious injuries and/or burns to children and adults.

To reduce the risk of tipping the range, the range must be secured by properly installed anti-tip device packed with the range. See installation instructions shipped with the bracket for complete details before attempting to install.

All ranges can tip and cause injuries.

Make sure the anti-tip bracket is installed:

Slide range forward.

Make sure the anti-tip bracket is securely attached to the wall behind the range.

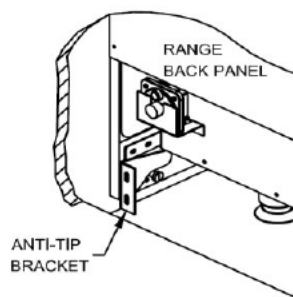

WARNING

This product can expose you to chemicals including carbon monoxide, which is known to the State of California to cause developmental harm.

For more information go to www.P65Warnings.ca.gov

The installation must conform with local codes or, in the absence of local codes, with the National Fuel Gas Code, ANSI Z223.1/NFPA 54 or, in Canada, the Natural Gas and Propane Installation Code, CSA B149.1.

WARNING

Never operate the top surface cooking section of the appliance unattended

Failure to follow this warning statement may result in fire, explosion or burn hazard that could cause property damage, personal injury or death.

If a fire should occur, keep away from the appliance and immediately call your fire department. **DO NOT ATTEND TO EXTINGUISH AN OIL/GREASE FIRE WITH WATER**

IMPORTANT SAFETY INFORMATION

READ ALL INSTRUCTIONS BEFORE USING THE APPLIANCE

▲WARNING Read all safety instructions before using the product. Failure to follow these instructions may result in fire, electrical shock, serious injury or death.

GENERAL SAFETY INSTRUCTIONS

▲WARNING NEVER use this appliance as a space heater to heat or warm the room. Doing so may result in carbon monoxide poisoning and overheating of the oven.

1. Use this range for its intended purpose as described in this instruction manual.
2. Have your range installed and properly grounded by a qualified installer in accordance with the provided installation instructions.
3. Any adjustment and service should be performed only by a qualified gas range installer or service technician. Do not attempt to repair or replace any part of your range unless it is specifically recommended in this manual.
4. Your range is shipped from the factory set for use with natural gas or propane (LP) gas. It can be converted for use with either. If required, these adjustments must be made by a qualified technician in accordance with the installation instructions and local codes. The agency performing this work assumes responsibility for the conversion.
5. Have the installer show you the location of the range gas shut-off valve and how to turn it off if necessary.
6. Plug your range into a 120-volt grounded outlet only. Do not removed the round grounding prong from the plug. If in doubt about the grounding of the home electrical system, it is your responsibility and obligation to have an ungrounded outlet in accordance with the National Electrical Code. Do not use an extension code with this range.
7. Before performing any service, unplug the range or disconnect the power supply at the household distribution panel by removing the fuse or switching off the circuit breaker.
8. Be sure all packing materials are removed from the range before operating to prevent ignition of these materials.
9. Avoid scratching or impacting glass displays. Doing so may lead to glass breakage. Do not cook on a product with broken glass. Shock, fire, or cuts may occur.
10. Do not leave children alone or unattended in an area where an appliance is in use. They should never be allowed to climb, sit or stand on any part of the range.
11. **▲CAUTION** Do not store items of interest to children in cabinets above an oven-children who climb onto the oven to reach items could be seriously injured.
12. Never block the vents (air openings) of the range. They provide the air inlets and outlets that are necessary for the range to operate properly with correct combustion. Air openings are located at the rear of the cooktop, at the top and bottom of the oven door, and at the bottom of the range.
13. Use only dry pot holders--moist or damp pot holders on hot surfaces may result in burns from steam. Do not let pot holders touch surface burners, burner grate, or oven heating element. Do not use a towel or other bulky fabrics in place of pot holders.

14. Do not touch the heating elements or the interior surface of the oven. These surfaces may be hot enough to burn even though they are dark in color. During and after use, do not touch, or let clothing or other flammable materials contact any interior area of the oven; allow sufficient time for cooling first. Other surfaces of the appliance may become hot enough to cause burns. Potentially hot surfaces include the burners, grates, oven vent opening, surfaces near the opening, crevices around the oven door, metal trim parts above the door, any backguard, or high shelf surface.

15. Do not heat unopened food containers. Pressure could build up and the container could burst, causing any injury.

⚠ WARNING

Extremely Heavy.

Proper equipment and adequate manpower are needed when move the range to avoid personal injury or damage to the unit or the floor.

Failure to follow this advice may result in damage or personal injury.

⚠ WARNING

DO NOT carry or lift the cooking range by the oven door handle or the control panel!



Correct



Incorrect



⚠ WARNING GENERAL SAFETY INSTRUCTIONS (cont.)

Cook food thoroughly to help protect against foodborne illness. Minimum safe food temperature recommendations can be found at www.IsItDoneYet.gov and www.fsis.usda.gov. Use a food thermometer to take food temperatures and check several locations.

Do not allow anyone to climb, stand or hang on the oven door, drawer or cooktop. They could damage the range or tip it over causing severe injury or death.

Keep the ventilator hood and grease filter clean to maintain good venting and to avoid grease fires. Turn the ventilator OFF in case of a fire or when intentionally "flaming" liquor or other spirits on the cooktop. The blower if in operation, could spread the flames.

⚠ WARNING KEEP FLAMMABLE MATERIALS AWAY FROM THE RANGE

Failure to do so may result in fire or personal injury.

Do not store or use flammable materials in an oven or near the cooktop, including paper, plastic, pot holders, linens, wall coverings, curtains, drapes and gasoline or other flammable vapors and liquids.

Never wear loose-fitting or hanging garments while using the appliance. These garments may ignite if they contact hot surfaces causing severe burns.

Do not let cooking grease or other flammable materials accumulate in or near the range. Grease in the oven or on the cooktop may ignite.

⚠ WARNING IN THE EVENT OF A FIRE, TAKE THE FOLLOWING STEPS TO PREVENT INJURY AND FIRE SPREADING

Do not use water on grease fires. Never pick up a flaming pan. Turn the controls off. Smother a flaming pan on a surface unit by covering the pan completely with a well-fitting lid, cookie sheet or flat tray. Use a multi-purpose dry chemical or foam-type fire extinguisher.

If there is a fire in the oven during baking, smother the fire by closing the oven door and turning the oven off or by using a multi-purpose dry chemical or foam-type fire extinguisher.

If there is a fire in the oven during self-clean, turn the oven off and wait for the fire to go out.

Do not force the door open. Introduction of fresh air at self-clean temperatures may lead to a burst of flame from the oven. Failure to follow this instruction may result in severe burns.

▲WARNING COOKTOP SAFETY INSTRUCTIONS

Never leave the surface burners unattended at medium or high heat settings. Foods, especially oily foods, may ignite resulting in fire that could spread to surrounding cabinets.

Never leave oil unattended while frying. If allowed to heat beyond its smoking point, oil may ignite resulting in fire that may spread to surrounding cabinets. Use a deep fat thermometer whenever possible to monitor oil temperature.

To avoid oil spillover and fire, use the minimum amount of oil when frying in a shallow pan and avoid cooking frozen foods with excessive amounts of ice.

Use proper pan size and avoid pans that are unstable or easily tipped. Select cookware that matches the size of the burner. Burner flames should be adjusted so that they do not extend beyond the bottom of the pan. Excessive flames may be hazardous.

When using glass/ceramic cookware, make sure it is suitable for cooktop use; others may break because of a sudden change in temperature.

To minimize the possibility of burns, ignition of flammable materials and spillage, cookware handles should be turned toward the center of the range without extending over nearby burners.

Do not use a wok with a round metal support ring. The ring may trap heat and block air to the burner resulting in a carbon monoxide hazard.

Do not attempt to lift the cooktop. Doing so may damage the gas tubing to the surface burners resulting in a gas leak and risk of fire.

Do not use aluminum foil to cover the grates or line any part of the cooktop. Doing so may result in carbon monoxide poisoning, overheating of the cooktop surfaces, or a potential fire hazard.

▲WARNING OVEN SAFETY INSTRUCTIONS

NEVER cover any slots, holes, or passages in the oven bottom or cover an entire rack with materials such as aluminum foil or oven liners. Doing so blocks air flow through the oven and may cause carbon monoxide poisoning. Never place foil or oven liners on the oven bottom. They can trap heat causing risk of smoke or fire.

Stand away from the range when opening the oven door. Escaping hot air or steam can cause burns to hands, face and/or eyes.

Never place cooking utensils, pizza or baking stones, or any type of foil or liner on the oven floor. These items can trap heat or melt, resulting in damage to the product and risk of shock, smoke or fire.

Place oven racks in desired location while oven is cool. If the rack must be moved while the oven is hot, be careful to avoid touching hot surfaces.

Do not leave items such as paper, cooking utensils, or food in the oven when not in use. Items stored in an oven can ignite.

Do not leave items on the cooktop near the oven vent. Items may overheat resulting in a risk of fire or burns.

Never broil with the door open. Open-door broiling is not advised due to overheating of control knobs.

Features of Your Range

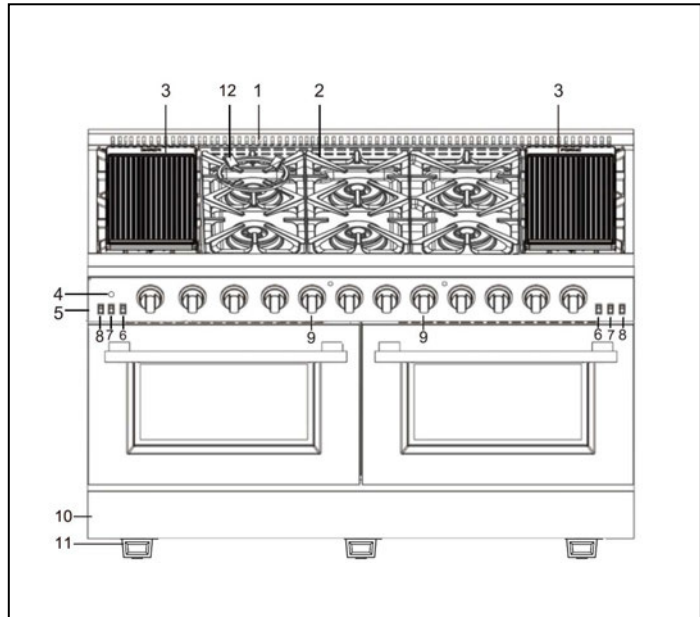
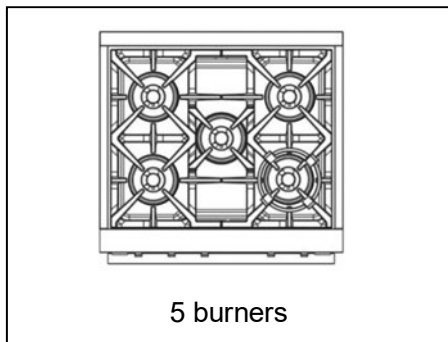
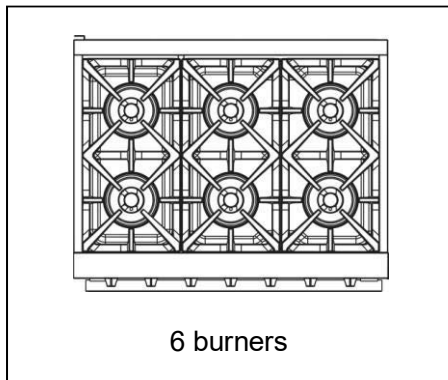
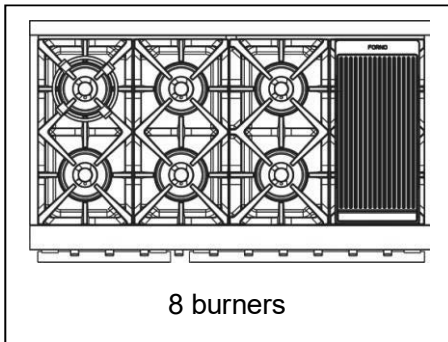
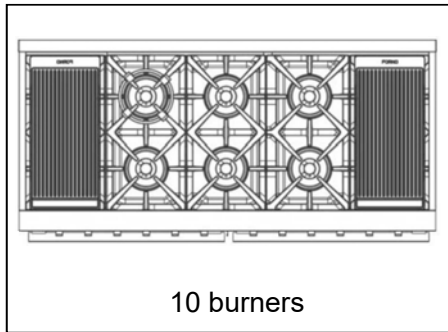













Not all features are on all models. Appearance may vary.

Feature Index	
1	Oven Vents
2	Cooktop Burner Grates
3	Griddle (on some models)
4	LED Light Switch
5	Control Panel
6	Rotisserie
7	Convention Fan Control Panel
8	Oven Lights
9	Oven/Broil Burner
10	Kick Panel
11	Leveling System
12	Wok Support

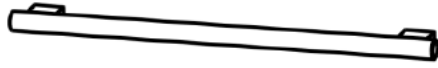



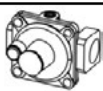





Installation Instructions

Before using your range

1. Remove all packaging material.
2. Check to make sure you have all of the accessories listed below

	LPG injector	FFSGS6260-30	17 sets
		FFSGS6260-36	20 sets
		FFSGS6260-48	27 sets
		FFSGS6260-60	34 sets
	Anti-tip bracket and screws (*2 sets for FFSGS6260-60)		1 set
	Burner Grills	FFSGS6260-30	2 pieces
	Burner Grills	FFSGS6260-36	3 pieces
		FFSGS6260-48	3 pieces
		FFSGS6260-60	3 pieces
	Burner Grills	FFSGS6260-48	1 piece
		FFSGS6260-60	2 piece
	Cook plate (Griddle)	FFSGS6260-48	1 piece
		FFSGS6260-60	2 pieces
	Wok Support		1 piece
	Oven door handle (*2 pcs for FFSGS6260-48 and FFSGS6260-60)		1 piece
	Burner & Cap (20000BTU)	FFSGS6260-30	5 sets
		FFSGS6260-36	6 sets
		FFSGS6260-48	8 sets
		FFSGS6260-60	10 sets
	Baking rack (*6 pcs for FFSGS6260-48 and FFSGS6260-60)		2 pieces
	rotisserie component (*2 sets for FFSGS6260-60)		1 piece
	Regulator (pre-installed)		1 piece
	Serial Number Sticker & Instruction Manual		1 set

YOU NEED TOOLS FOR INSTALLATION. (not supplied with the range)

 Screwdriver	 Wrench	 Socket wrench	 Allen key	 Tape measure & Pencil
 Protective gloves	 Hammer	 Adjustable wrench	 Adjustable pliers	 Drill

Door Handle Installation

The door handle is not preinstalled. Find it in the front side of the whole package. Follow the illustrations below to install the door handle quickly and easily.

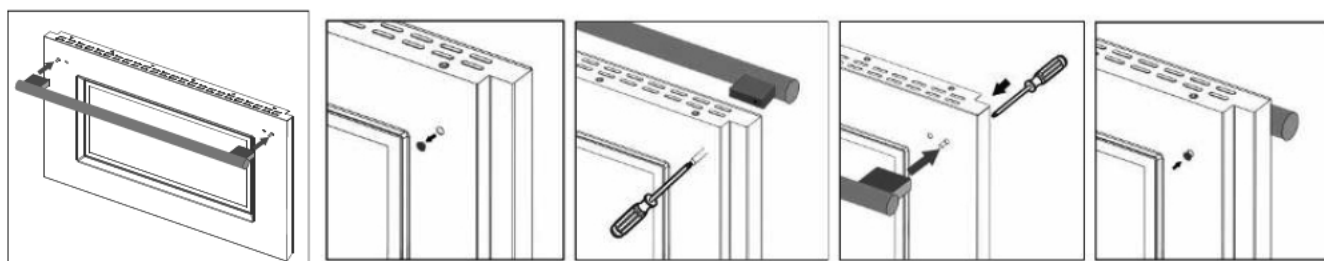

1. Remove the round black rubber mat from the inside door.
2. Insert the screwdriver to the hole.
3. Install the handle with the exposed screw.
4. Repeat for the other side as step 1 to 3.
5. Put the round black rubber mats back to cover the two holes on the inside door.

Cooktop Burner Grates Installation

Remove the packing materials from the cooktop burner grates. Place the burner grates to the right position. Pay attention to the middle right grates as illustrated, as the thicker side should be in the left.

Put the griddle (only for FFSGS6260-48 and FFSGS6260-60) and the wok support to the burner(s) you like to cook.

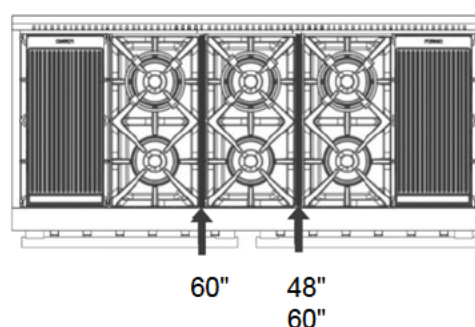

Oven Racks Installation

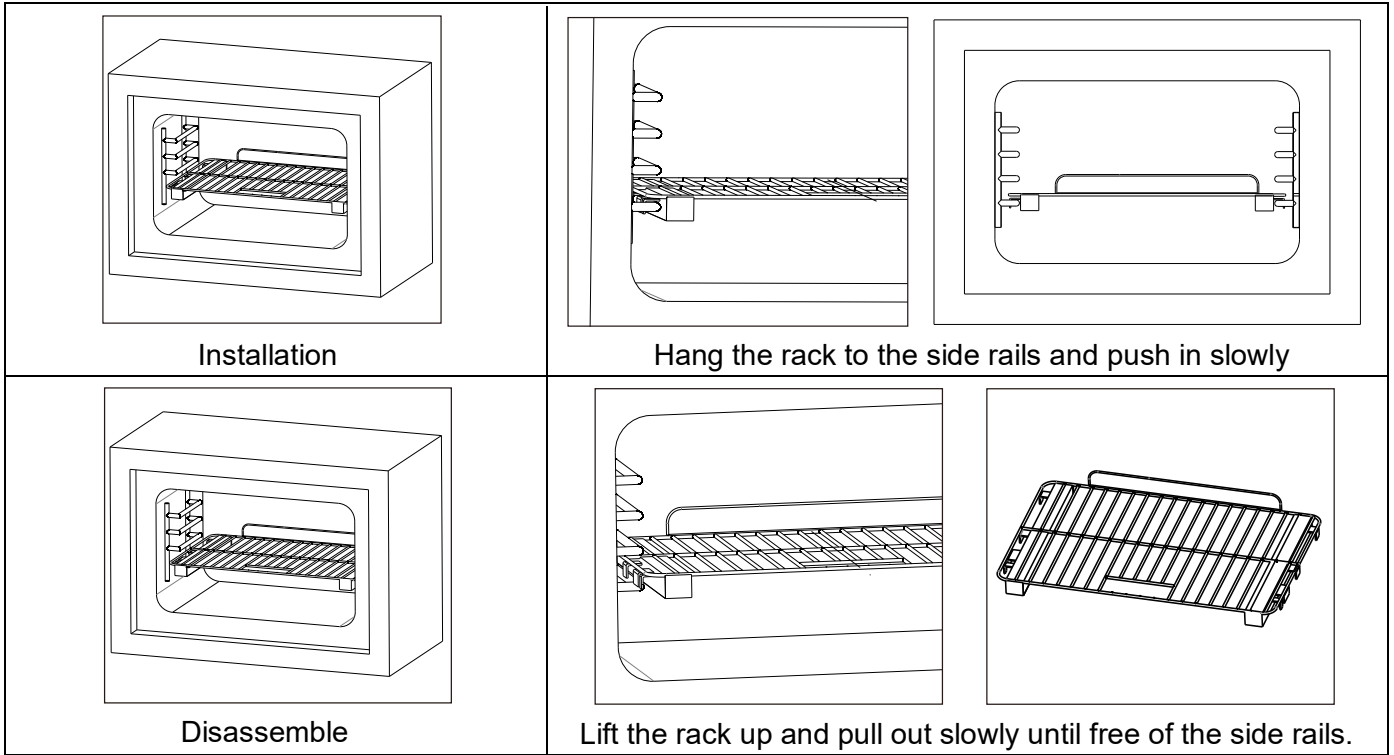

Electrical

Your range must be electrically grounded in accordance with local codes or, in the absence of local codes, in accordance with the National Electrical Code (ANSI/NFPA 70, latest edition). In Canada, electrical grounding must be in accordance with the current CSA C22.1 Canadian Electrical Code Part 1 and/or local codes.

The power supply must be the correct polarity. Reverse polarity will result in continuous sparking of the electrodes, even after flame ignition. If there is any doubt as to whether the power supply has the correct polarity or grounded, have it checked by a qualified electrician.

ELECTRICAL REQUIREMENTS

<u>Electrical Supply</u>	<u>Grounded, 110/120 VAC, 60 Hz</u>
<u>Service</u>	<u>15 amp or 20 amp dedicated circuit</u>
<u>Receptacle</u>	<u>3-prong grounding-type</u>
<u>Power Cord</u>	<u>5' (1.3 m)</u>

⚠ WARNING

Electrical Grounding Instructions: this cooking range is equipped with a three-prong (grounding) plug for your protection against shock hazard and should be plugged directly into a properly grounded three-pronged receptacle.

Do Not cut or removes the grounding prong from the plug.

⚠ CAUTION Label all wires prior to disconnection when servicing controls. Wiring errors can cause improper and dangerous operation. Verify proper operation after servicing.

Grounding

The power cord is equipped with a three-prong (grounding) plug which mates with a standard three-prong grounding wall receptacle to minimize the possibility of electrical shock hazard from the range.

All cord connected appliance shall include instructions relative to location of the wall receptacle and a warning to the user to disconnect the electrical supply before serving the appliance.

Where a standard two-prong wall receptacle is encountered, it is the responsibility and obligation of the customer to have it replaced with a properly grounded three-prong wall receptacle. Do not cut or remove the grounding prong from the power cord.

Gas Supply

Installation must comply with local codes or, in the absence of local codes, with the National Fuel Gas Code, ANSI Z223.1 / NFPA 54. In Canada, installation must conform to the current natural Gas Installation /code, CAN 1-1.1-M81 and with local codes where applicable.

This range has been design-certified according to ANSI Z21.1b-2012 latest edition.

GAS REQUIREMENTS

NATURAL GAS		WC
Regulator Pressure		5" (12.5 mb)
Minimum Supply Pressure		6"
Maximum Supply Pressure	14" (34.9 mb), 0.5 psi (3.5 kPa)	
LP GAS		WC
Regulator Pressure		10" (25 mb)
Minimum Supply Pressure		11"
Maximum Supply Pressure	14" (34.9 mb), 0.5 psi (3.5 kPa)	

The min and max gas supply pressure stands for the pressure at the Gas Shut-Off Valve.

⚠ WARNING Do not obstruct the flow of combustion air into the range and ventilation air away from the range.

Ventilation: it is recommended that the unit be operated with an oven head, vented exhaust hood of sufficient size and capacity.

Electric Power Supply Requirements

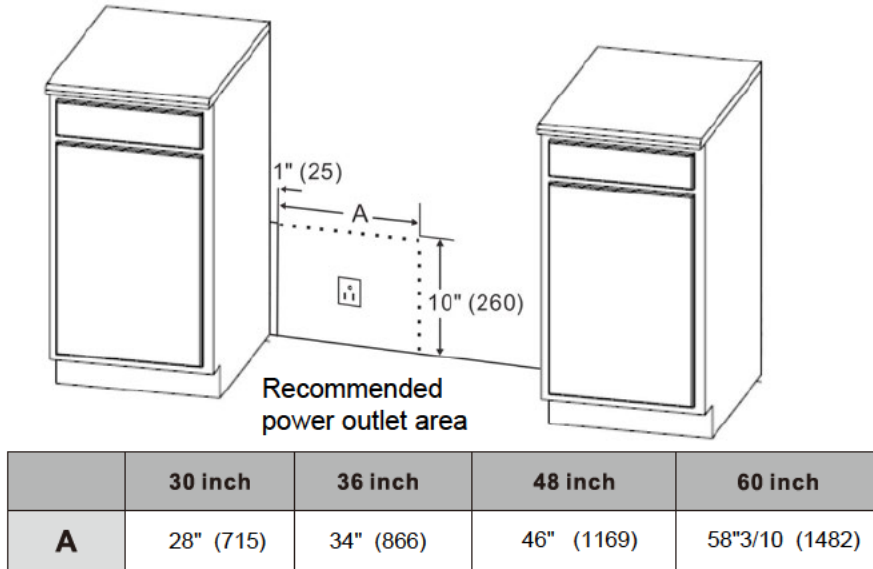

⚠ WARNING For reference only, please refer to the real object.

Pressure Regulator

Since service pressure may fluctuate with local demand, every gas cooking range must be equipped with a pressure regulator on the incoming service line for safe and efficient operation.

For GAS RANGE models : The pressure regulator shipped with the range has two female threads 1/2" NPT for the 30" and the 36" or 3/4" NPT for the 48" and the 60".

For DUAL FUEL models : The pressure regulator shipped with the range has two female threads 1/2" NPT for the 30" and the 36" or 3/4" NPT for the 48" and the 60"

The regulator is preinstalled in order to be accessible when the appliance is installed in its final position.

Pressure regulator can withstand a maximum input pressure of 0.5 psi (3.5 kPa), and is set at 5" WC outlet pressure when used on NATURAL GAS and 10" WC outlet pressure when used on LIQUID PROPANE.

Gas Shut-off Valve (not included)

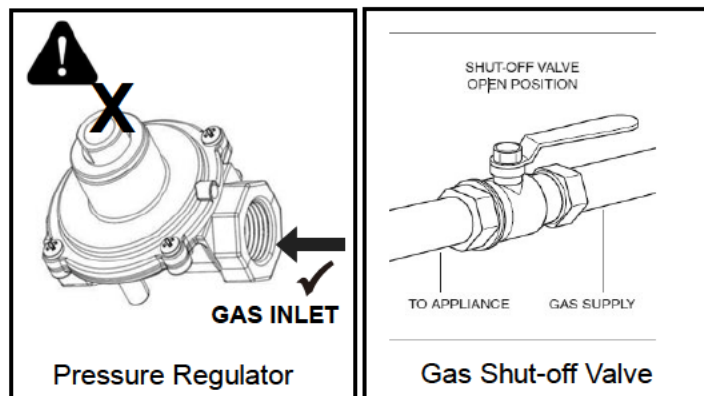

The supply line must be equipped with an approved external gas shut-off valve located near the range in an accessible location. Do not block access to the shut-off valve. Refer to the illustration below. A 3/4" (19 mm) ID gas supply line must be provided to the range. If local codes permit, a certified, 3' (.9 m) long, 1/2" (13 mm) or 3/4" (19 mm) ID flexible metal appliance connector is recommended to connect the unit's 1/2" NPT (30" & 36") or 3/4" NPT (48" & 60") female inlet to the gas supply line. Pipe joint compounds suitable for use with natural or LP gas should be used.

The appliance and its shut-off valve must be disconnected from the gas supply piping system during any pressure testing of the system at test pressures in excess of 0.5 psi (3.5 kPa). The appliance must be isolated from the gas supply piping system by closing its individual manual shutoff valve during any pressure testing of the system at test pressures equal to or less than 0.5 psi (3.5 kPa).

Product Dimensions and Cabinets

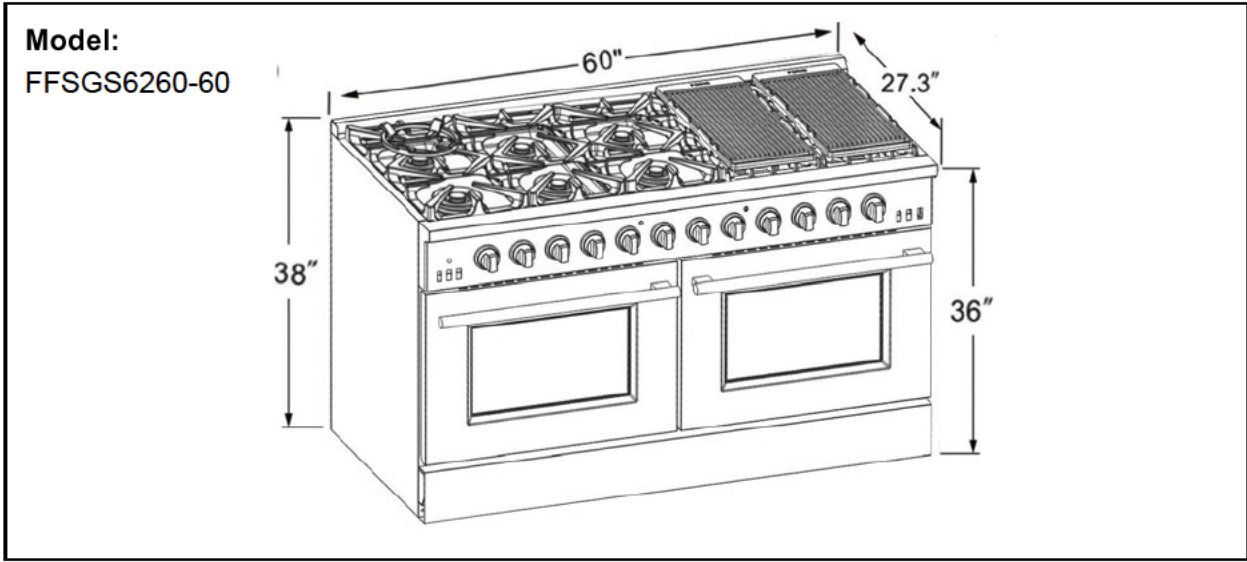
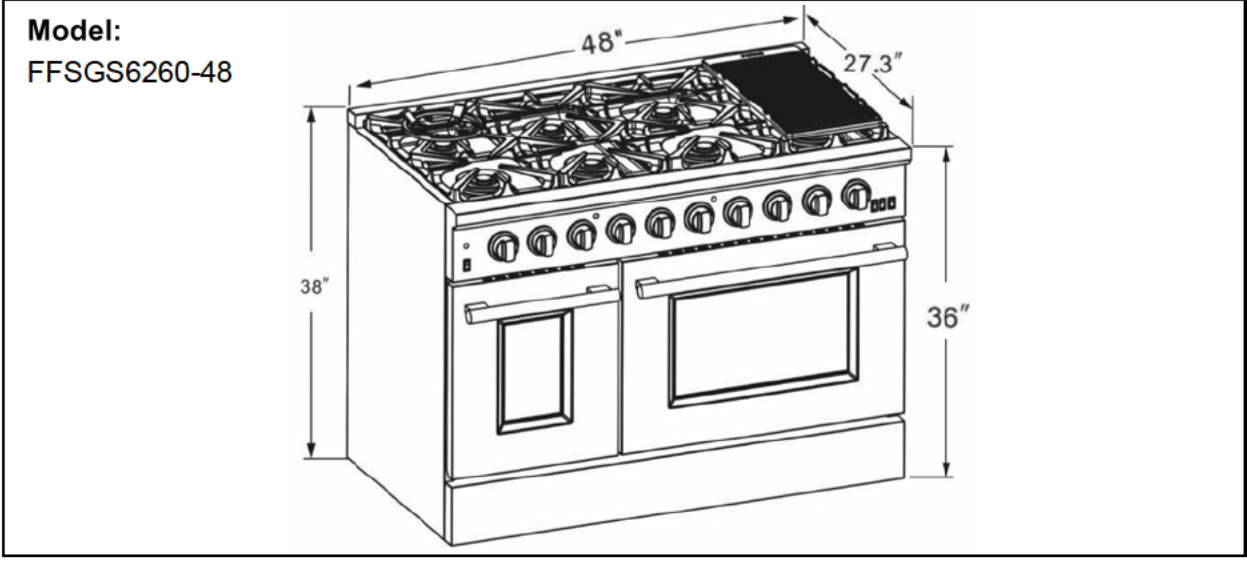
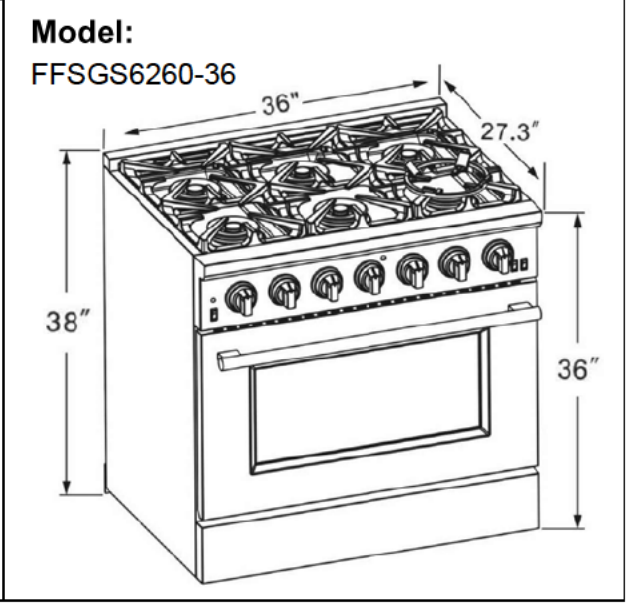
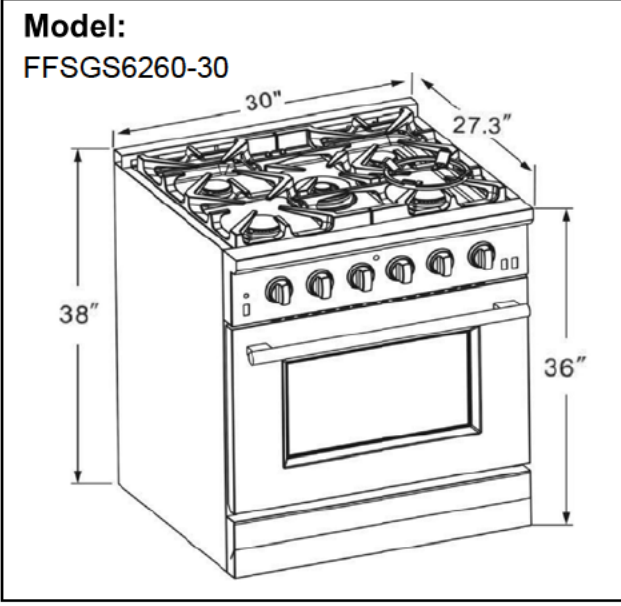

This range may be installed directly adjacent to existing countertop-height cabinets (36" or 91.5 cm from the floor). To achieve the best look, the cooktop should be level with the cabinet countertop. This can be accomplished by raising the unit using the adjustment spindles on the legs.

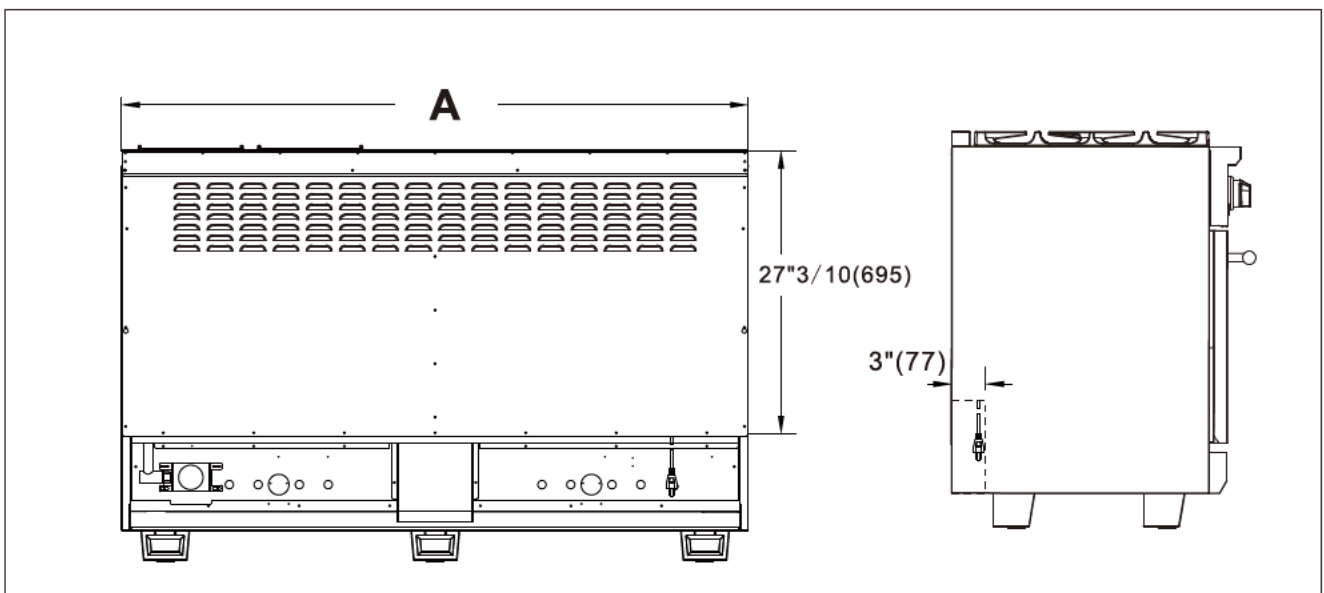
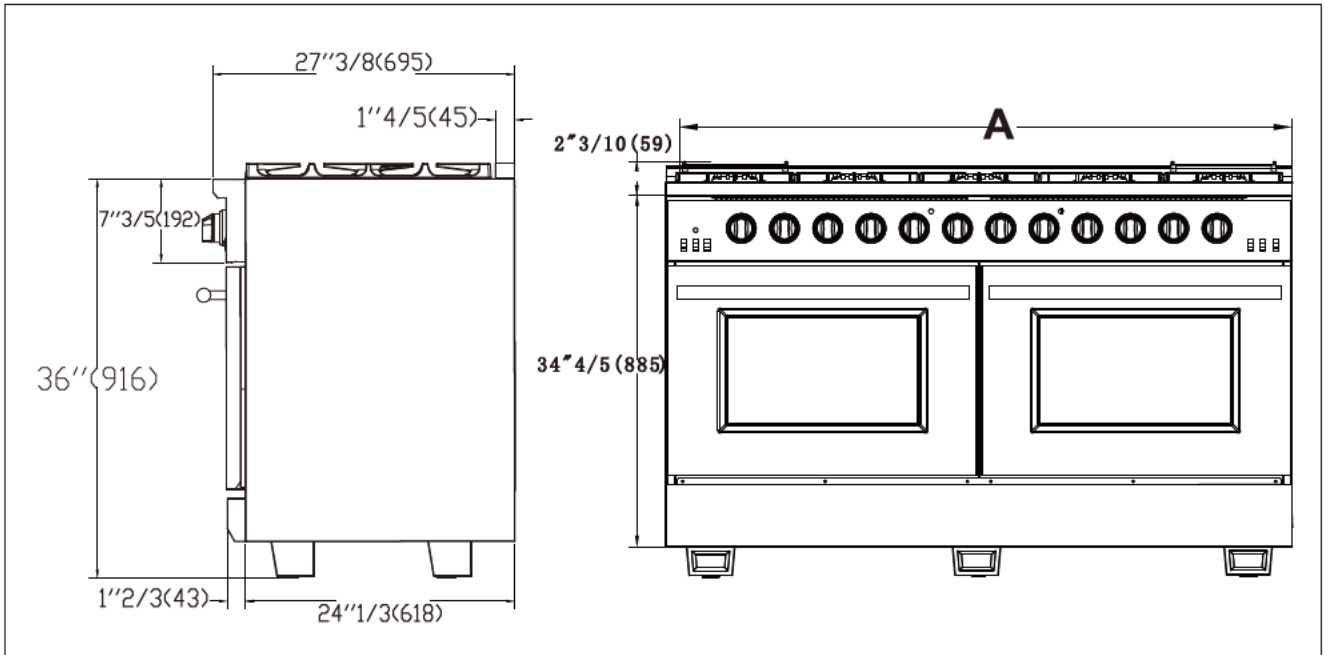

	30 inch	36 inch	48 inch	60 inch
A	30"(763)	36"(915)	47"9/10(1218)	59"8/10(1520)

FFSGS6260-30

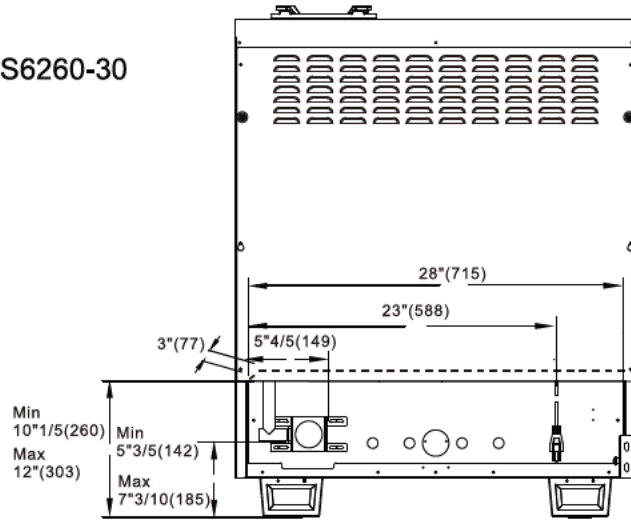

FFSGS6260-36

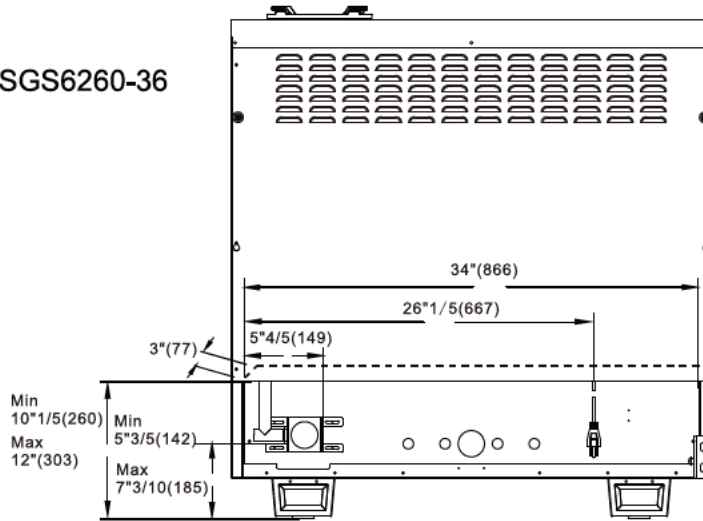

FFSGS6260-48

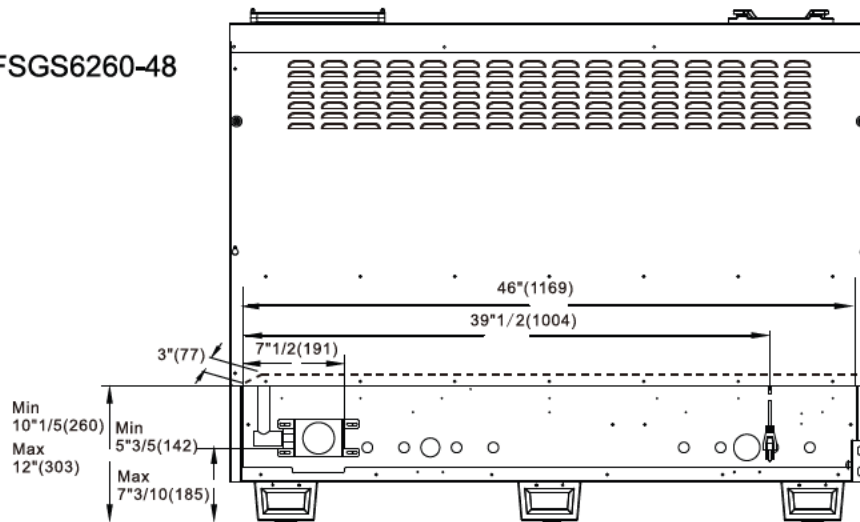

FFSGS6260-60

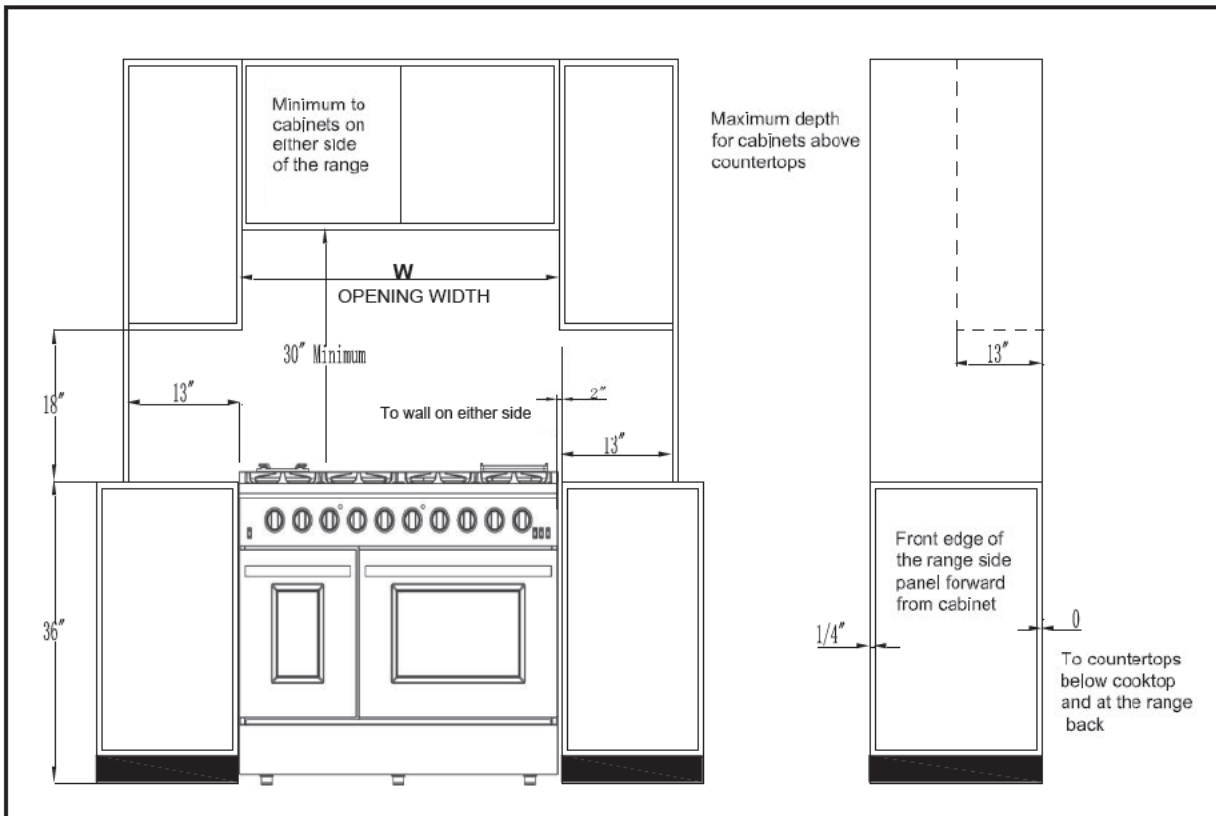
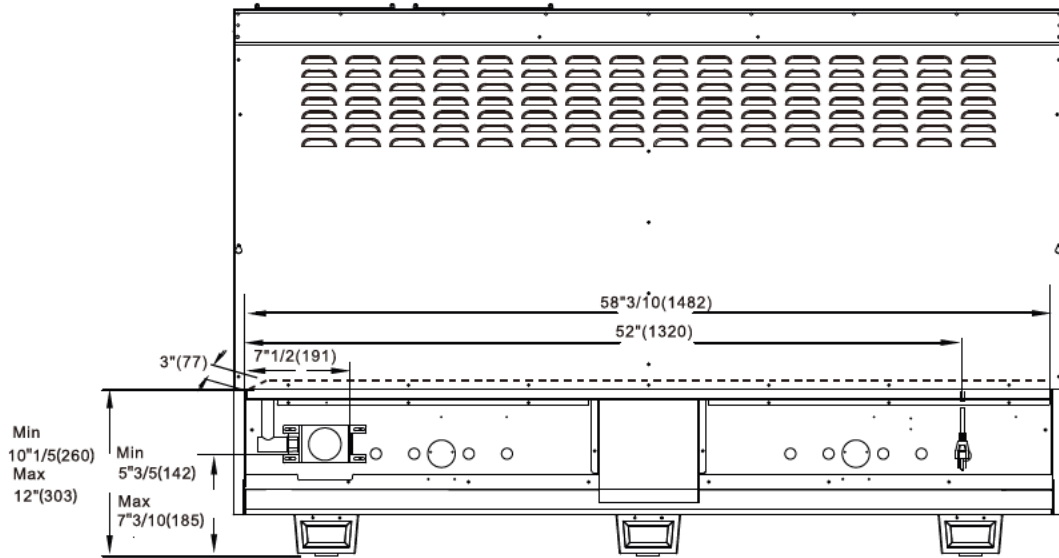

OPENING WIDTH	W
30" Model	30" (762)
36" Model	36" (914)
48" Model	48" (1219)
60" Model	60" (1520)

Exhaust Hood Installation

The bottom of the hood should be 30" min. to 36" above the countertop. This would typically result in the bottom of the hood being 66" to 72" above the floor. These dimensions provide safe and efficient operation of the hood.

After Installation:

1. Check ignition of cooktop burners.
2. Check the air shutter adjustment – sharp blue flame, with no yellow tipping or lifting flames.
3. Check ignition of oven burner.
4. Visually check tubular burner (oven burner) re-ignition to be sure both rows of burner ports are relighting each time.
5. Check for gas leaks at all gas connections (using a gas detector, never a flame).
6. Check oven bake and convection bake function.

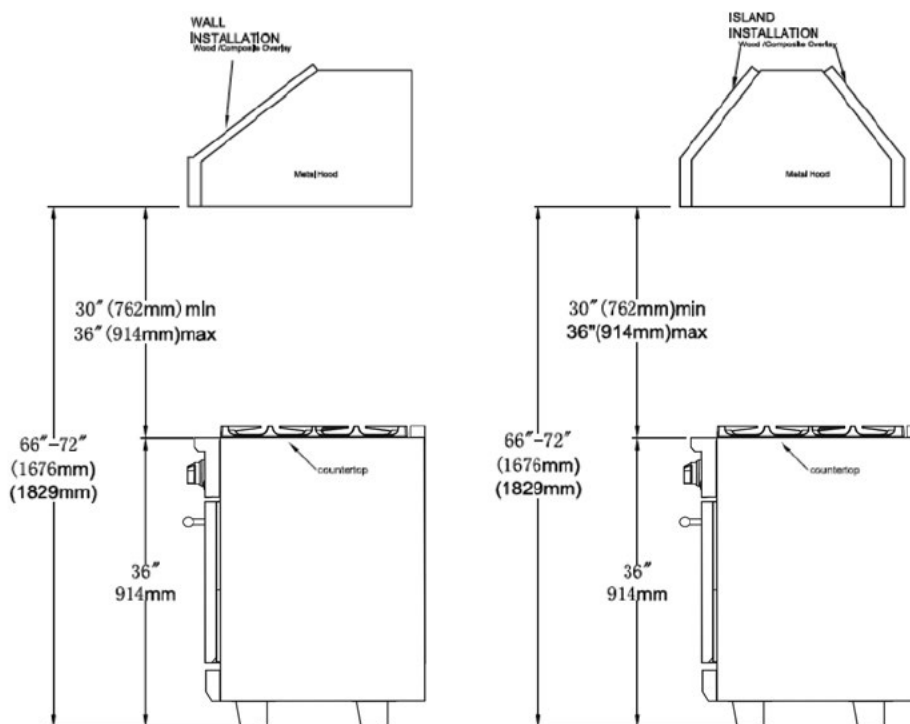

Gas Conversion Operation

This cooking range can be used with LP gas and NG gas. It is shipped from the factory adjusted for use with NG (Nature Gas). Conversion nozzles are included. Follow the instruction shown below for gas conversion.

⚠ WARNING Gas conversion shall be conducted by a factory-trained professional. Call the customer service hotline to identify a factory-trained professional near your home.

⚠ WARNING Before carrying out this operation, disconnect the range from gas and electricity.

The gas conversion procedure for this range includes 8 steps:

1. Pressure regulator
2. Cooktop burners
3. Oven burner
4. Broil burner
5. Gas valves
6. Reconnect Gas and Electrical Supply
7. Air shutter oven burner
8. Installation of new rating label

The conversion is not completed if all 8 steps have not been concluded properly. Before performing the gas conversion, locate the package containing the replacement nozzles shipped with every range.

STEP 1: Pressure Regulator

To access the gas regulator, pull the range away from the cabinet wall. The gas regulator is located at the bottom back left corner of the range.

⚠WARNING Electrical shock hazard can occur and result in injury or death. Disconnect electrical power to the range before servicing. Do not remove regulator or allow it to turn during servicing.

- a. Unscrew the cap from the regulator. Do not remove the spring from the regulator.
- b. Unscrew the insert from the cap and turn it over so the longer stem is facing the cap. Replace insert on the cap. Replace the cap on the regulator.

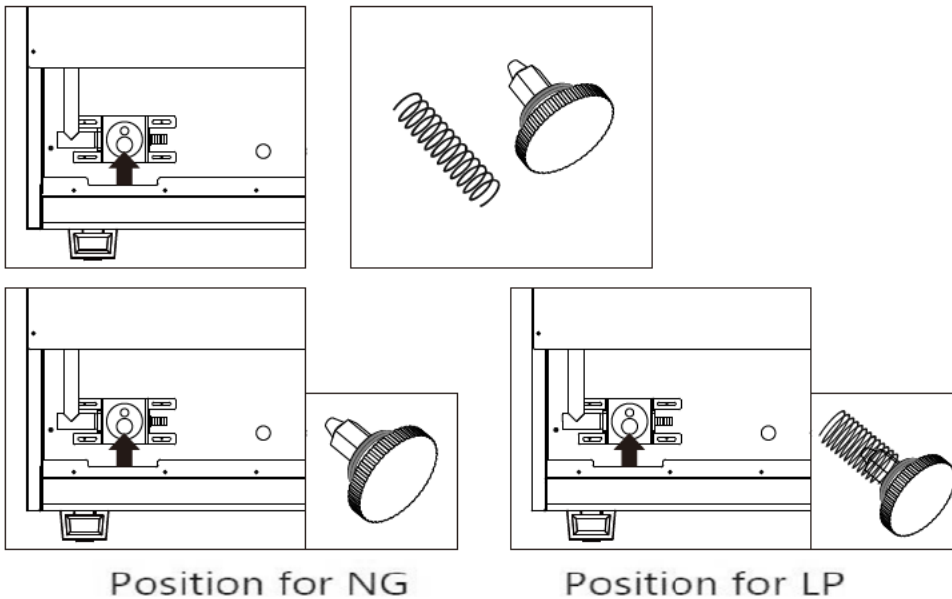

STEP 2: Cooktop Burners

- a. Remove cooking grates, burner caps and inner burner rings.
- b. Lift off outer burner heads and burner bases.
- c. Remove the factory installed natural gas nozzles from the center of the nozzle holders using a 7mm socket wrench. Replace the LP nozzle in each nozzle holder. Tighten each nozzle until snug. Use caution not to over tighten.

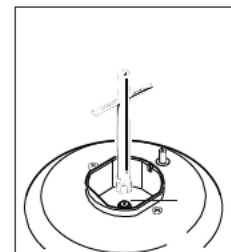

Socket Wrench

⚠CAUTION Care should be taken when removing and replacing gas components. Use proper support to prevent damage to components.

IMPORTANT: Each nozzle has a number indicating its flow diameter printed on the body. Consult the table below for matching nozzles and burners.

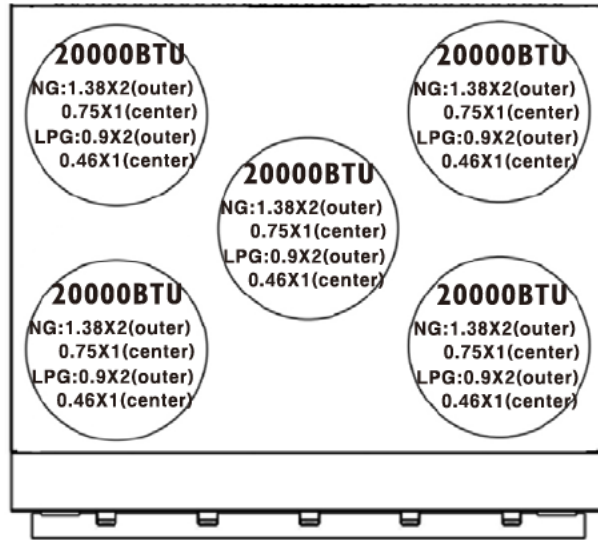

Model:FFSGS6260-30

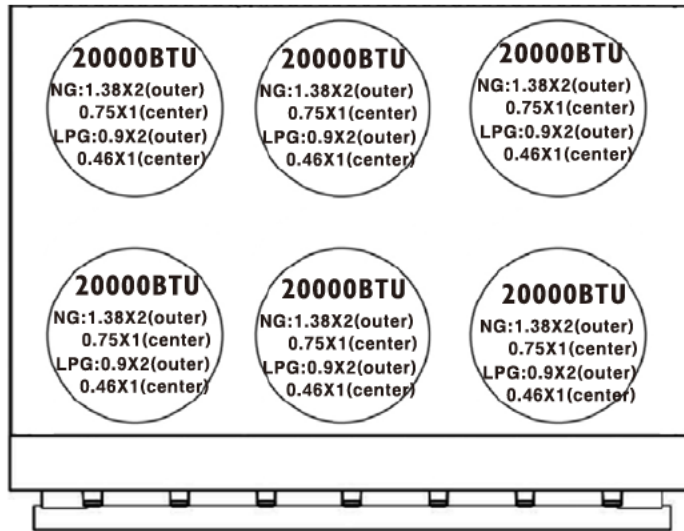

Model:FFSGS6260-36

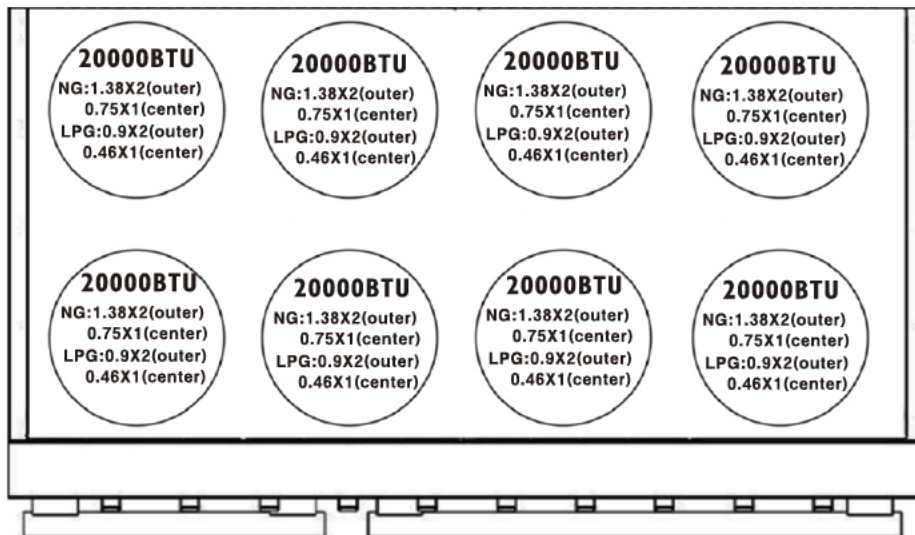

Model:FFSGS6260-48

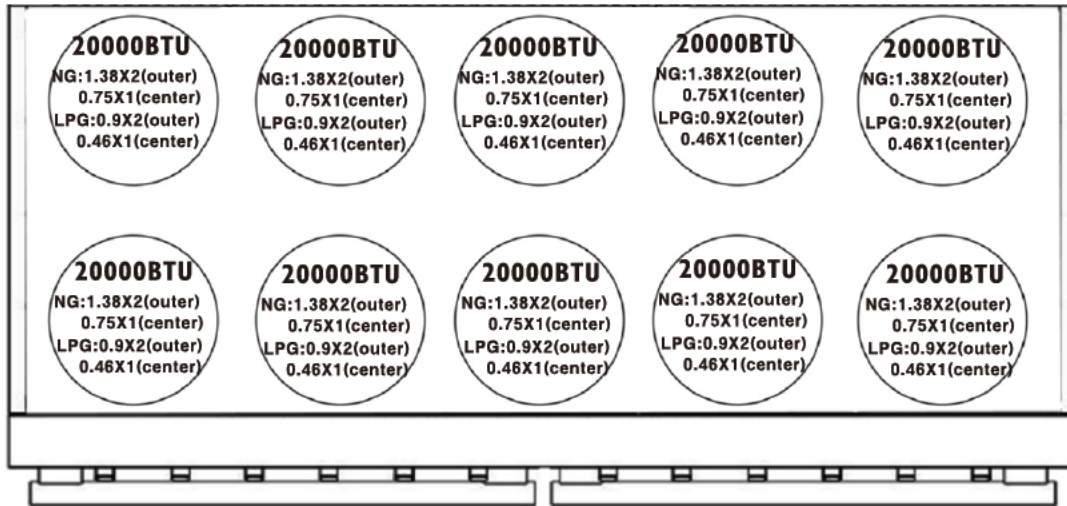

Model:FFSGS6260-60

IMPORTANT: Save the nozzles removed from the range for future use.

STEP 3: Oven Burner

a. Remove 3 screws between the kick panel and the oven door . Hold the toe kick panel on both ends and slowly pull away towards the front.

b. Remove 2 screws which holding the nozzle bracket and locate the nozzle.

Replace with oven burner nozzle, size 1.32mm and tighten. Replace the nozzle bracket, aligning the new nozzle into the air shutter of the oven burner.

Repeat upon steps for 18"oven (48" ranges only).

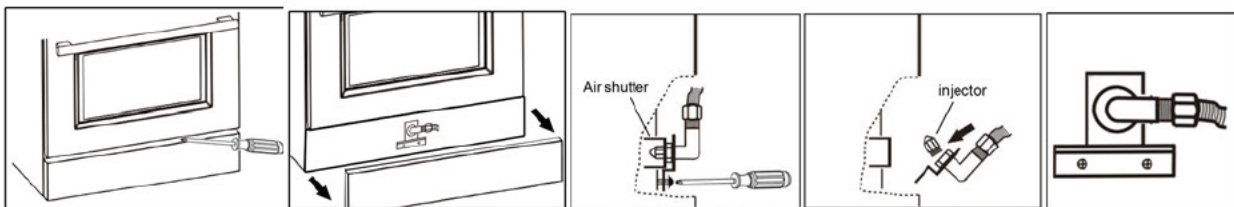

		Model:FFSGS6260-30	Model:FFSGS6260-36	Model:FFSGS6260-48	Model:FFSGS6260-60
Oven	NG	2.2	2.2	2.2	2.2*2
	LPG	1.39	1.39	1.39	1.39*2
18" Oven	NG			1.7	
	LPG			1.12	

STEP 4: Broil Burner

- a. Remove the back panel.
- b. Remove 2 screws which fixing the nozzle bracket and locate the nozzle.
- c. Using a 5/8" or 19mm open wrench, remove the gas line from the nozzle holder. Using a 1/2" open wrench, remove the nozzle from the orifice holder. Replace with 0.94 mm oven broiler nozzle.

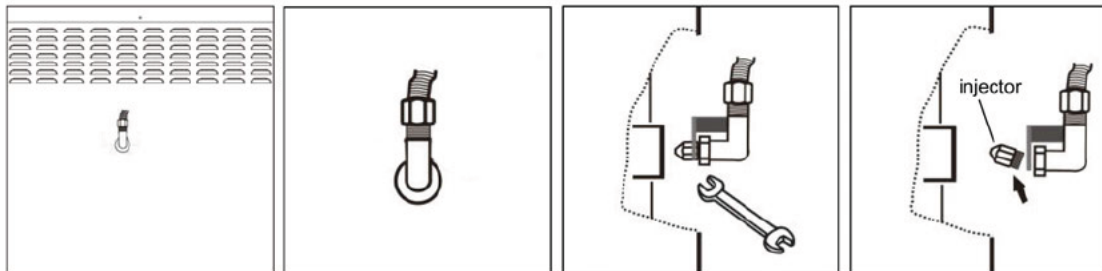

		Model:FFSGS6260-30	Model:FFSGS6260-36	Model:FFSGS6260-48	Model:FFSGS6260-60
Broil	NG	1.8	1.8	1.8	1.8*2
	LPG	1.19	1.19	1.19	1.19*2

STEP 5: Gas Valve

- a. Remove control knobs.
- b. Using a flat screwdriver, adjust main burner bypass jets toward to 1/4 circle for LP until the flame is normal. For 9,000btu and 15,000btu burners, please refer to fig.1, which is in the center of valve axis. For 20,000btu burners, please refer to fig.2, which is in the left side of valve axis.

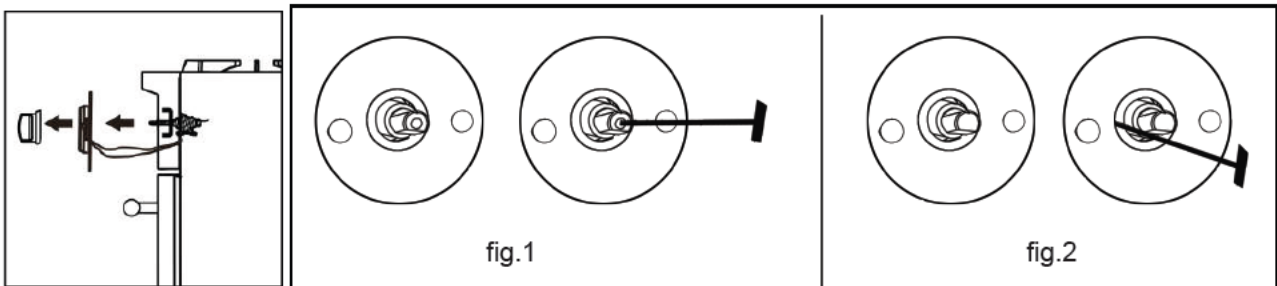

STEP 6: Reconnect Gas and Electrical Supply

Leak testing of the range shall be conducted according to the installation instructions provided with the range.

Before operating the range after the gas conversion, always check for leaks with a soapy water solution or other acceptable method in at gas connections installed between the gas inlet pipe of the range, gas regulator, and the manual shut-off valve.

Use soapy solutions to check for leakage on all joints.

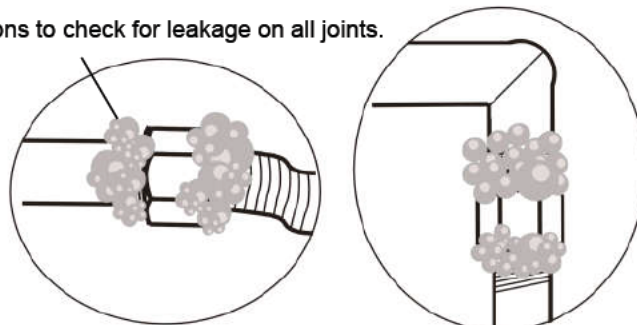

▲WARNING DO NOT use a flame to check for gas leaks!

STEP 7: Air Shutter Oven Burner (no necessary)

The air shutter for the oven burner may need adjustment, especially if the unit has been converted for use with LP. The approximate flame height at the oven burner is one inch (distinctive inner blue flame).

To determine if the oven burner flame is acceptable:

- a. With the kick plate removed, set the oven to bake at 350° F and observe the flame. If the flame yellow in color, increase the air shutter opening size. If the flame is blue and lifting away from the burner, reduce the air shutter opening size.
- b. Turn off the oven and allow it to cool before adjusting the air shutter. To adjust, loosen the lock screw, reposition the air shutter and tighten the lock screw. Retest the burner by repeating the steps above. When the burner flame is a distinct blue colour and burning steadily, the air shutter is adjusted correctly.

STEP 8: Installation of New Rating Label

Record the model and serial number on the LP / Propane Rating serial plate provided in this kit. The information can be obtained from the existing Rating / Serial plate. Place the new plate as close as possible to the existing Rating / Serial plate on the range.

Preparation

Before moving the range, protect any finished flooring and secure oven door(s) closed to prevent damage.

The oven door(s) can be removed to lighten the load or to fit the unit through a doorway. Only remove if necessary. Do not remove the griddle or any other component. Door removal should only be done by a certified installer or service technician.

Placement

Do not lift or carry the oven door by the door handle.

Use an appliance dolly to move the range near the opening. Remove and recycle packing materials. Do not discard the anti-tip bracket supplied with the range.

Leveling

Raise the range to the desired height by adjusting the legs. The legs can be adjusted by rotating the metal leg clockwise to raise and counter clockwise to lower.

Anti-Tip Bracket

To prevent the range from tipping forward, the anti-tip bracket must be installed. Refer to the illustration on page 5.

Gas Supply Connection

All connections to the gas piping must be wrench-tightened. Do not overtighten or allow pipes to turn when tightening.

When all connections have been made, check that all range controls are in the "OFF" position and turn on the main gas supply valve.

If a flexible metal connector is being used, verify it is not kinked, then attach the gas supply line to the regulator on the range. Open the valve and check for leaks by placing a liquid detergent solution onto all gas connections. Bubbles around connections indicate a gas leak. If a leak appears, close the shut-off valve and adjust connections.

Leak testing of the appliance shall be conducted according to the manufacture's instructions. Use some soap water (50% water and 50% soap) or a leak detector at all joints and connections to check for leaks in the system. Do not use a flame to check for gas leaks.

The appliance must be isolated from the building's gas supply piping system by closing its individual manual shut-off valve during any pressure testing of the gas supply piping system at test pressure equal to or less than 0.5 psi (3.5kPa).

Getting Started

Before you start cooking, please take the following steps.

- Remove the exterior and interior packing.
- Remove the protective film on steel and aluminum parts.
- Clean the range thoroughly with hot water and a mild detergent. Rinse and dry with a soft cloth to remove any residual oil and grease left over from the manufacturing process.
- Check that surface burner components are assembled correctly.
- Furnish the interior of the oven by inserting the shelves and tray.

Cooktop Operation

The burner design combines all burner parts in one assembly. The burner cap must be seated flatly on the burner. Refer to the illustration below.

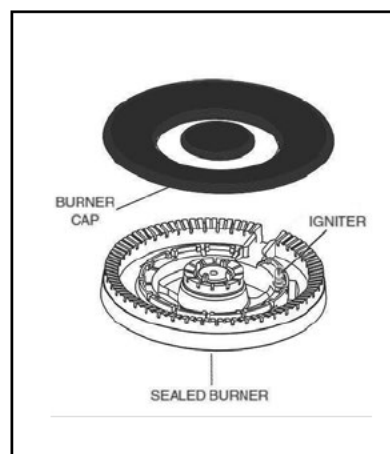

Ignition

To light up the cooktop burners, push and turn the appropriate control knob counter clockwise to “Hi” position. You will hear a clicking noise –the sound of ignition pin sparking.

Once burner ignition has been achieved, turn the burner control knob to adjust to desired flame intensity.

Heat Settings:

Hi	Ignites the burners.
Simmer	Melting small quantities, steaming rice, warming food, melting chocolate or butter.
Low	Melting large quantities.
Low-Medium	Low-temperature frying, simmering large quantities, heating milk, cream sauces, gravies.
Medium	Sautéing and browning, braising, pan-frying, maintaining slow boil on large quantities.
Medium-Hi	High-temperature frying, pan boiling, maintaining slow boil on large quantities.
Hi	Boiling liquid quickly, deep frying.

⚠ CAUTION Never leave pans on a high setting unattended. Be careful when cooking food in fat or grease; it can become hot enough to ignite.

Simmer and Boil

A smaller flame will give the best results when simmering. Small flames offer precise cooking performance for delicate foods, keeping food warm, melting chocolate or butter, and for cooking over low heat for long period of time.

The highest (larger) flame settings provide the maximum heat that is available on your range. This setting should be used for heavy cooking jobs such as boiling water and cooking pasts.

Flame Size

- When you select the flame size, watch the flame when you turn the knob.
- Any flame larger than the bottom of the cookware is wasted.
- The flame should be steady and blue in color. Foreign material in the gas line may cause an orange flame during initial operation.

Power Failure

- If the gas does not ignite within four seconds, turn off the valve and allow at least five minutes for any gas to dissipate. Repeat the lighting procedure.
- In the event of a power failure, the surface burners can be lighted manually. Hold a lighted match near a burner and turn the knob counter-clockwise to “HI”. After burner lights, turn knob to the desired setting.

Burner Grates

1. The grates must be properly positioned before cooking. Improper installation of the grates may result in scratching of the cooktop and / or poor combustion.
2. Do not operate the burners without a pan or utensil on the grates.

Griddle Operation (available on the 48" and 60" models)

Before Using the Griddle

1. Clean the griddle thoroughly with warm, soapy water to remove dust or any protective coating.
2. Rinse with clean water and wipe off to dry with soft, clean, lint-free towel/cloth.

Use of the Cook plate (Griddle)

Your **FORNO** range may have come with a standard reversible grill/griddle. For best use and results please read below.

Pre-heat gently - Because the FORNO grill/griddle is so large it can take time for it to heat evenly. Once it's up to temp it will stay there for a long time! We recommend starting with your range set to low heat and gradually increasing the heat until you get to your target temp. It's easier to make a grill hotter once it's already warmed up, by pre-heating slowly you can control the heat more easily. To be efficient with your time you can start the pre-heating process while you're getting your ingredients together. It typically takes 10-15 minutes to completely pre-heat the FORNO grill/griddle this when pre-heating in this manner. Then enjoy your cooking experience on the FORNO grill/griddle

Start low and don't overheat! - You might get the urge to turn your burners up to full blast the first time you use the FORNO grill/griddle, but don't! Burners only need to be set to 1/3 to 1/2 power to heat the grill/griddle to over 500 degrees. Most chefs agree that the maximum cooking temperature you'll ever need is 500-550 degrees for searing a steak.

⚠CAUTION The surface of the griddle is hot after use. Please allow sufficient time for the griddle to cool prior to cleaning.

Cooktop Cleaning Tips

- To prevent the cooktop from discoloring or staining, clean cooktop after each use, and wipe up acidic or sugary spills as soon as the cooktop has cooled.
- The sealed burners of your range are not secured to the cooktop and are designed to be removed. Boil overs or spills will not seep underneath the cooktop. The burners should be cleaned after each use.

Oven Light

The oven light is controlled by a push switch on the control panel.

The light can be used while cooking or cleaning the oven.

⚠WARNING Check that power is disconnected from the electrical box before replacing the light bulb. Allow the oven to cool completely, then unscrew the light cover and remove the light bulb by unscrewing it from the socket. Replace with a 40-watt halogen bulb.

LED Light Switch

Use the LED light switch to turn on the LED lights when the room becomes dark.

Oven Roasting

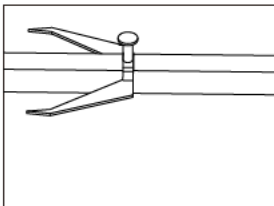
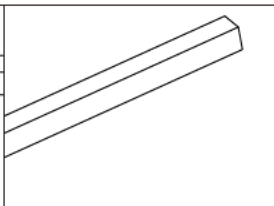
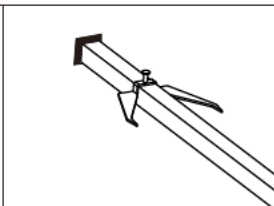
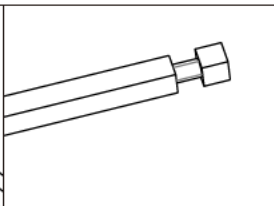
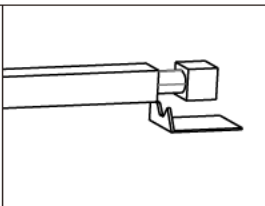
				
Use the screws on the rotisserie rod to adjust the distance between the forks.	Insert the smooth side of the rotisserie rod into the rotisserie motor on the right side.	Hang the side with sink limit of the rotisserie rod to the hook on the left side.		

Some ranges are equipped with an automatic rotisserie for roasting.

The rotisserie feature allows for an even cooking and all-over browning of the meat while preventing the meat from cooking in its rendered grease. The rotisserie will turn the meat allowing it to baste itself while roasting.

Be sure that you have received the rotisserie accessories included with your unit.

(1) Rotisserie Spit – Rod

(2) Rotisserie Forks

Always use the broiling pan when using the rotisserie to catch the rendered grease and allow for easy access to the meat when putting in and removing the rotisserie spit – rod.

To use the rotisserie, preheat the oven to the desired temperature. Secure the meat to be cooked onto spit-rod using the rotisserie forks.

Insert the rotisserie spit-rod into the rotating assembly and select the desired rotisserie function (light on or light off).

Make sure that the baking / broiling tray is below the meat being cooked to avoid spills and to prevent possible flare-up of the oven flames.

ALWAYS TURN THE ROTISSERIE FUNCTION TO OFF BEFORE REMOVING THE ITEMS FROM THE OVEN.

⚠CAUTION – USE HEAT RESISTANT GLOVES WHEN REMOVING THE ITEMS FROM THE OVEN.

Oven Operation

Oven Baking Tips

1. Never cover any slots, holes or passages in the oven bottom or cover an entire rack with materials such as aluminum foil. Doing so blocks air flow through the oven and may cause carbon monoxide poisoning. The aluminum foil lining may also trap heat, causing a fire hazard. Do not use aluminum foil on any porcelain surface. Doing so will damage the porcelain and affect its durability.
2. Position the racks before preheating the oven.
3. Reduce the oven temperature 25°F (14°C) when cooking in heat-proof glass or glass ceramic dishes.

Preheating

Allow the oven to preheat before placing food in the oven. Preheating is necessary for good results when baking cakes, cookies, pastry and breads.

Remove any cookware before preheating with the infrared broiler. Foods will stick on hot metal. To preheat, turn the “Oven” selector knob to the “Broil” position. Wait for the burner to become hot, approximately 2 minutes.

Note: Condensation or fogging on the inside of the oven door glass is normal while preheating and it will usually evaporate by the end of the preheating cycle.

Oven Function

Natural Airflow Bake occurs when heat is transferred into the oven from the bake burners in the bottom of the oven cavity. Heat is then circulated by natural airflow. This is a traditional bake setting.

Convection Bake

Heat is transferred from the bake burners in the bottom of the oven cavity to the oven cavity itself. The convection fan at the rear of the oven then circulates it. This convection process provides a more even heat distribution throughout the oven cavity.

Using multiple racks is possible for large-batch baking. Convection cooking is faster, can be done at lower temperatures and provides more even temperatures than regular cooking.

Convection Roast

The convection fan circulates the heated air evenly over and around the food. Using a broiler pan, heated air will be circulated over the around the food being roasted. The heated air seals in juices quickly for a moist and tender product, while at the same time creating a rich golden brown exterior. When convection roasting, it is important that you use the broiler pan for best convection roasting results. The pan is used to catch grease spills and has a cover to prevent grease splatters.

Convection Defrost

With temperature control off, the motorized fan in the rear of the oven circulates air. The fan accelerates natural defrosting of the food without heat. To avoid illness and food waste, do not allow defrost food to remain in the oven for more than two hours without being cooked.

Convection Dehydrate

With the temperature control on 175°F, warm air is radiated from the bake burners in the bottom of the oven cavity and is circulated by a motorized fan in the rear of the oven. Over a period of time, the water is removed from the food by evaporation. Removal of water inhibits growth of microorganisms and retards the activity of enzymes.

Broiler Operation

Note: Door must be closed during broiling operation.

The broil burner is located at the top of the oven. This burner heats the metal screen until it glows. The glowing screen produces heat, searing the outside of broiled foods and sealing in juices. Broiling is a method of cooking tender cuts of meat directly under the broiler in the oven.

Oven broiling is done with the oven door closed. It is normal and even necessary to have some smoke to give the food a broiled flavor.

Setting Broil

The "Oven" selector knob controls the Broil feature. When broiling, heat radiates downward from the oven broiler for even coverage. The Broil feature temperature is 500°F (260°C).

Used together, the broil pan and insert allow dripping grease to drain and be kept away from the high heat of the oven broiler. DO NOT use the broil pan without the insert. DO NOT cover the broil pan insert with foil. The exposed grease could catch fire. To set the oven to Broil:

1. Place the broiler pan insert on the broiler pan. Then place the food on the broiler pan insert.
2. Arrange the interior oven rack and place the broiler pan on the rack. Be sure to center the broiler pan and position it directly under the broil burner. If preheating the broil burner first, position the broiler pan after the broil burner is preheated.
3. Turn the selector knob to Broil.

The oven indicator light will remain on until the selector knob is turned to the off position or the temperature control cycles off.

Position the rack at the correct level. The farther away the food is from the broiler, the more well done it will be inside. Preheating the oven is necessary. Push in and turn the knob to BROIL. Turn the food over at the halfway point. Always pull the rack out to the "stop" position before turning or removing food.

Oven Cleaning Tips

1. After each use, and once cooled, clean splatters and spills immediately.
2. Do not allow foods with a high sugar or acid content to remain on the oven cavity surface.
3. Use an oven cleaner to clean the oven cavity.

Oven Thermostat & Cooking times

The numbers printed on the control panel indicate the increasing oven temperature value (°F).

To regulate the temperature, set the desired number on the control knob indicator.

Note: The BROIL position is only to turn on the broil burner.

Cooking times can vary according to the type of food, its density and its size. It is advisable to watch when cooking for the first time and to check results since similar results are obtained when preparing the same dishes under the same conditions.

Use the thermostat to control the temperatures, and control the time according to the cooking guides.

Care and Cleaning Recommendations

Stainless steel	Use a non-abrasive stainless steel cleaner and apply with a soft lint-free cloth. To bring out the natural luster, lightly wipe surface with a water-dampened microfiber cloth followed by a dry polishing cloth. Always follow the grain of stainless steel.
Burner grates Oven rack guides	Remove and place on a flat surface near the sink. Clean with hot water and mild detergent or paste of baking soda and water. Do not immerse in water. Towel dry.
Burner pan	Remove surface debris before cleaning to help speed up the cleaning process and decrease the chance of scratching the surface during cleaning. Using mild abrasive cleaners or spray degreasers, clean and rinse the surface and dry immediately to avoid streaking. To clean hard water stains, use white vinegar and water. Rinse and dry immediately.
Surface burners	Allow to cool. Use mild detergent or spray degreaser to clean. Rinse with water and towel dry.
Control knobs	Using a damp cloth, wipe with a mild detergent or spray degreaser; rinse and dry. Do not place in dishwasher.
Oven interior	Use mild abrasive cleaners, spray degreasers. Use a razor blade to gently lift baked on foods from oven cavity and window. For stubborn stains, spray with a mild abrasive cleaner or spray degreaser. Wash the entire oven cavity with soap and water to remove all cleaning chemicals.
Oven racks	To clean the upper rack, use mild detergent and a scouring pad. Rinse and dry. To clean the bottom pan, discard grease and wash with hot water and mild detergent. Rinse and dry. The stainless steel upper rack is dishwasher safe. However, do not place the porcelain-coated rack or pan in dishwasher.

Troubleshooting Tips

Before you call for service

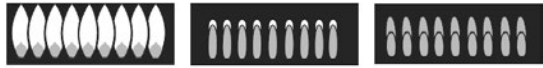
Range does not operate	<p>Check that power is on.</p> <p>Check that electrical power to range and home circuit breaker is on.</p>
Burners Do Not Light Or Spark Randomly	<p>Electrical plug is not plugged into a live power outlet.</p> <p>Gas supply not turned on.</p> <p>Burner parts not replaced correctly.</p> <p>Holes in the simmer rings or slits in the burner rings are clogged.</p> <p>Clogged nozzles, or wet burners or electrodes.</p> <p>A fuse in your home may be blown or circuit breaker tripped.</p>
Burners Have Yellow Or Yellow-Tipped Flames	<p>Burner parts not replaced correctly.</p> <p>A. Yellow flames: Call for service.</p> <p>B. Yellow tips on outer cones: Normal for propane (LP) gas.</p> <p>C. Soft blue flames: Normal for natural gas.</p>  <p>If burner flames look like (A), call for service. Normal burner flames should look like (B) or (C), depending on the type of gas.</p>
Burner Flames Very Large Or Yellow	The range may be connected to the wrong fuel type. Contact the person who installed your range or made the conversion.
Burner Flames Contain Orange Flickers	Airborne dust; cool-mist humidifier; debris on or inside burner.
Oven Lights Do Not Work	The light bulb is defective. Replace the bulb.
Oven Racks Are Hard To Slide	Do not spray with a cooking spray or other lubricant sprays. See Full extension oven racks in the Care and Cleaning section.
Food Does Not Bake Or Roast Properly	<p>The oven controls are improperly set. See the Baking or Roasting section.</p> <p>Oven not preheated for a long enough time.</p>

	<p>Incorrect cookware or cookware of improper size being used.</p> <p>Racks in the wrong position. See the Baking or Roasting section.</p> <p>Use a foil tent to slow down browning during roasting.</p>
Food Does Not Broil Properly	<p>This model is designed for closed door broiling only. Close the door. Always broil with the door closed.</p> <p>The oven controls are not set at BROIL. See the Broiling section.</p> <p>Improper rack position.</p> <p>Cookware is not suited for broiling. Use the broiling pan and rack that came with your oven.</p> <p>Aluminum foil used on the broiling pan and rack has not been fitted properly and slit as recommended.</p>
Oven Temperature Too Hot Or Too Cold	<p>Need to adjust the oven knob temperature setting.</p>
Steam From The Vent	<p>When using the convection mode, it is normal to see steam coming out of the oven vent. As the number of racks or amount of food being cooked increases, the amount of visible steam will increase.</p>
Burning Or Oily Odor Emitting From The Vent	<p>This is normal in a new oven and will disappear in time.</p>
Strong Odor	<p>This is temporary. An odour caused by the insulation around the inside of the oven is normal for the first few times the oven is used.</p>
Convection Fan Not On All The Time	<p>The convection fan (depending on the function you are using) may cycle on and off until the function is over or the door is opened for optimized performance.</p> <p>This is normal. In addition, the convection fan may cycle in the clockwise and counter clockwise direction until the function is over or the door is opened.</p>
Condensation Or Fogging On The Inside of the Door Glass	<p>Condensation or fogging on the inside of the oven door glass is normal during the preheating of the oven and will evaporate usually by the end of the preheating cycle.</p>
Cracking Or Popping Sound During Cleaning	<p>This is normal. This is the sound of the metal heating and cooling during both the cooking and cleaning functions.</p>
Excessive Smoking Occurs During Cleaning	<p>The oven is heavily soiled. Turn the Oven Mode Selector and the Temperature knobs to OFF. Open the windows to rid the room of smoke. Wait until the locked door indicator light goes off. Wipe up excess soil and do the cleaning again.</p>

PLEASE READ BEFORE USING YOUR OVEN



For Forno Commercial Style Ranges Models:
FFSGS6244, FFSGS6156, FFSGS6260, FFSGS6187,
FFSGS6239, FFSGS6125, FFSGS6291
Useful information for your oven:

- This oven is very powerful.
- To avoid burns, please use oven mitts when manipulation oven racks and be careful not to touch the oven door when in use.
- All knobs may reach 123F when oven is in use – although the standard regulations is max 148F please handle with care.
- For better Broil efficiency pre-heat to 500F for 8 Minutes and turn the knob to broil until you see the flame and wait 3 to 4 seconds before releasing.

Cooking tips:

1- Pizza: Place rack on bottom level at 375F for 16 minutes then broil 2 to 3 minutes on top level.

2- Vegetables: Place rack second from bottom at 350F for 14 to 17 minutes.

3- Place rack on middle level at 350F for:

Fish: 4 to 6 minutes

Meats 10oz: 9-14 minutes

Chicken 8oz: 14-19 minutes

4- Turkey and Braised Meats:

Place rack at bottom level at 350F, no need to rise the cooking temperature above 350F for the first 20 minutes.

forno.ca
1-866-231-8893
info@forno.ca



Wire Diagram

FFSGS6260-30

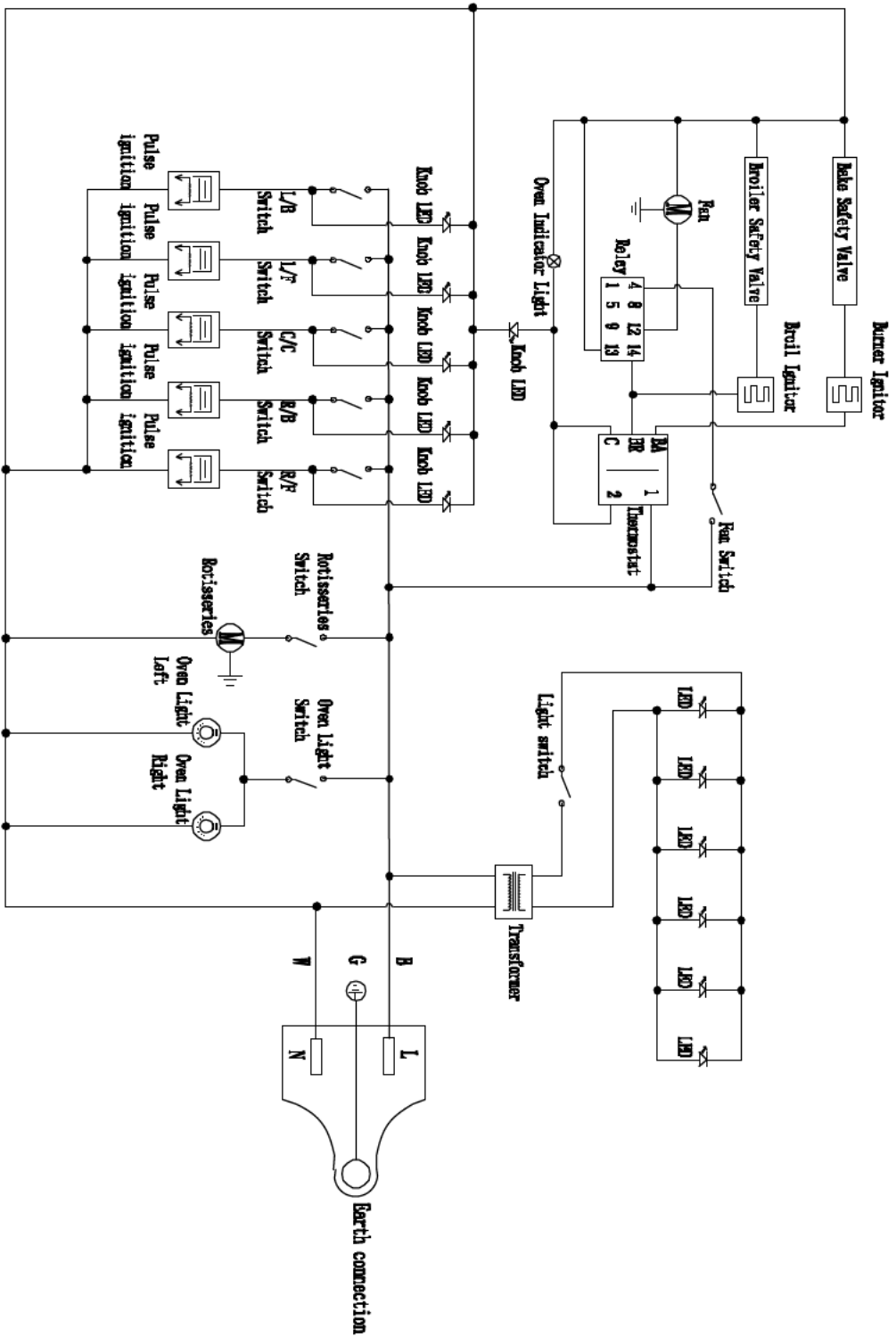

Caution: Label all wires prior to disconnection when servicing controls. Wiring errors can cause improper and dangerous operation. Verify proper operation after servicing.

FFSGS6260-36

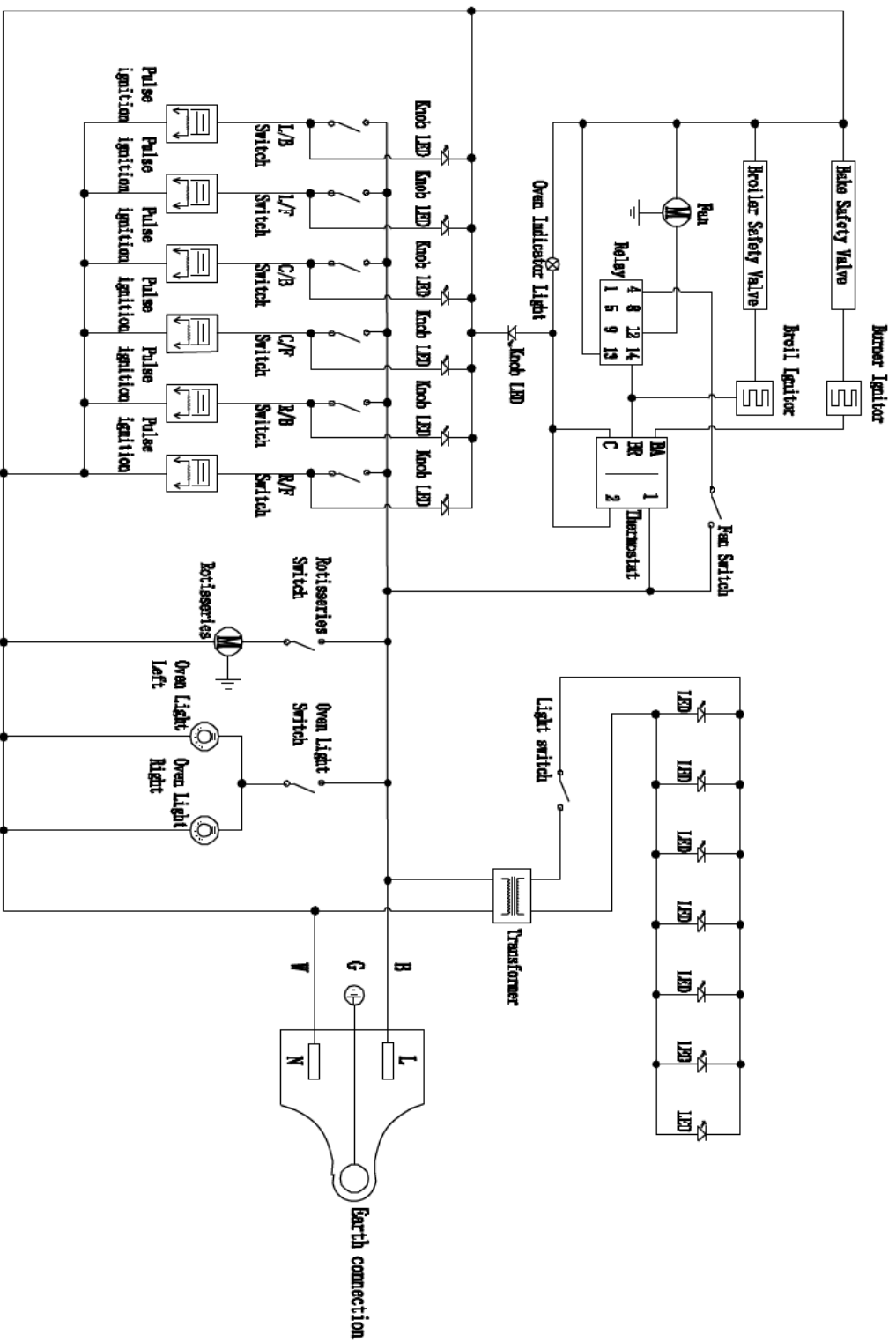

Caution: Label all wires prior to disconnection when servicing controls. Wiring errors can cause improper and dangerous operation. Verify proper operation after servicing.

FFSGS6260-60

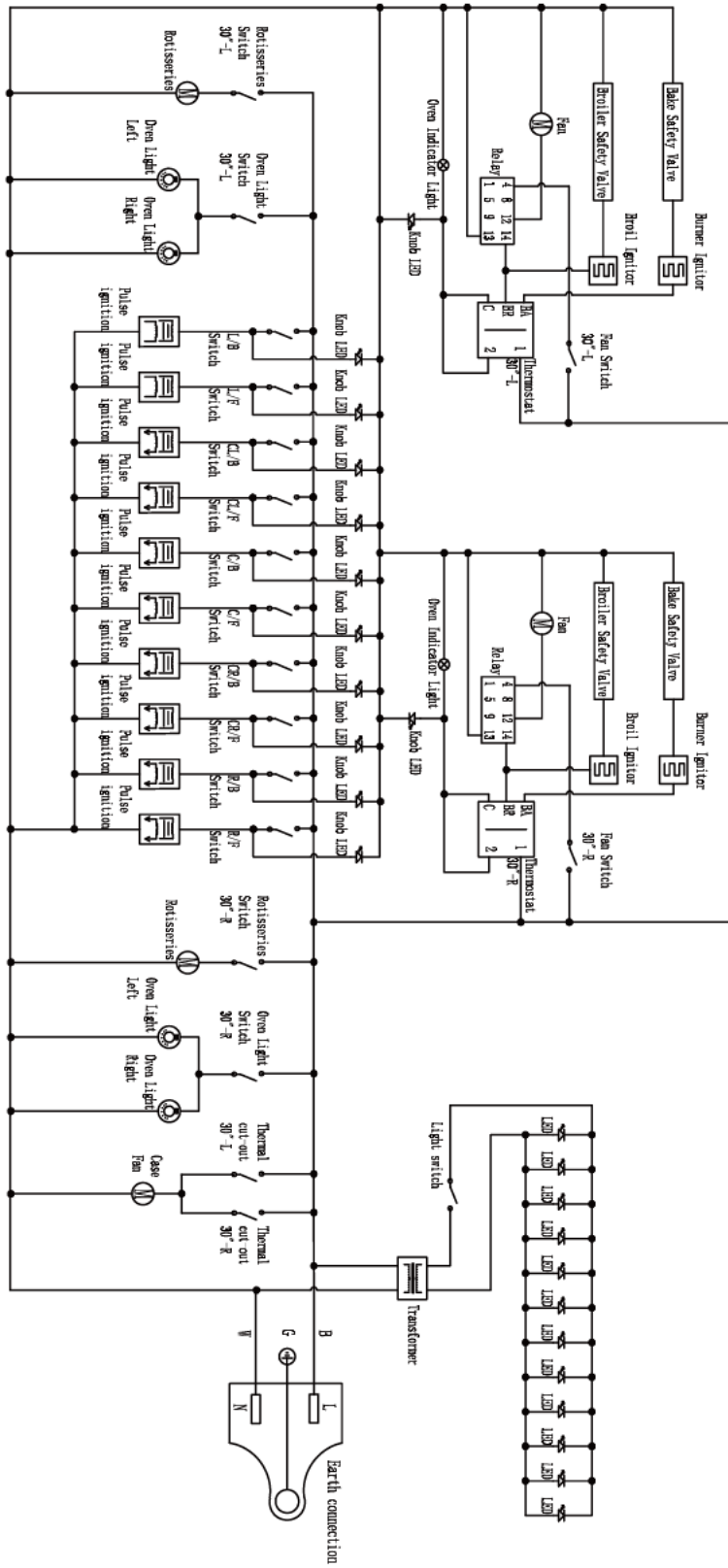

Caution: Label all wires prior to disconnection when servicing controls. Wiring errors can cause improper and dangerous operation. Verify proper operation after servicing.