

19MM LOG CABIN, 4M X 3M , HALF GLAZED DOUBLE DOORS, THREE SHORT WINDOWS.

## BEFORE YOU START PLEASE READ INSTRUCTIONS CAREFULLY

- Check the pack and make sure you have all the parts listed.
- When you are ready to start, make sure you have the right tools at hand (not supplied) including a Phillips screwdriver, Stanley knife, wood saw, step ladder and drill with 2mm bit.
- Ensure there is plenty of space and a clean dry area for assembly.

## TIMBER

As with all natural materials, timber can be affected during various weather conditions. For the duration of heavy or extended periods of rain, swelling of the wood panels may occur. Warping of the wood may also occur during excessive dry spells due to an interior moisture loss. Unfortunately, these processes cannot be avoided but can be helped. It is suggested that the outdoor building is sprayed with water during extended periods of warm sunshine and sheltered as much as possible during rain or snow.

## BUILDING A BASE

When thinking about where the building and base are going to be constructed: Ensure that there will be access (60cm) to all sides for maintenance work and annual treatment.

Ensure the base is level and is built on firm ground, to prevent distortion. Refer to diagrams for the base dimensions. The base should be slightly smaller than the external measurement of the building, i.e. the cladding should overlap the base, creating a run off for water. It is also recommended that the floor be at least 25mm above the surrounding ground level to avoid flooding.

## TYPES OF BASE

- Concrete 75mm laid on top of 75mm hard-core.
- Slabs laid on 50mm of sharp sand.

**Whilst all products manufactured are made to the highest standards of safety and in the case of childrens products independently tested to EN71 level, we cannot accept responsibility for your safety whilst erecting or using this product.**

Refer to the instructions pages for your specific product code



All buildings should be erected by two adults



Winter = High Moisture = Expansion  
Summer = Low Moisture = Contraction



2mm Drill bit

For ease of assembly, you **MUST** pilot drill all screw holes and ensure all screw heads are countersunk.



### CAUTION

Every effort has been made during the manufacturing process to eliminate the prospect of splinters on rough surfaces of the timber. You are strongly advised to wear gloves when working with or handling rough sawn timber.



For ease of assembly use a rubber mallet to fit the log boards. Do **NOT** use a heavy hammer.



Ensure to measure and check before cutting boards.

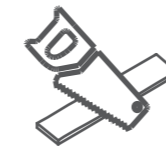

It is advisable to use a hand saw when cutting roof and floor boards.



To ensure log boards are even, use a spirit level to check each layer has been installed correctly.

Screws & Nails



Bolts



To identify the fixings required for each step use a measuring tape.

Overall Dimensions:  
 Width = 4016mm  
 Depth = 3319mm  
 Height = 2375mm

Base Dimensions:  
 Width = 3808mm  
 Depth = 2804mm

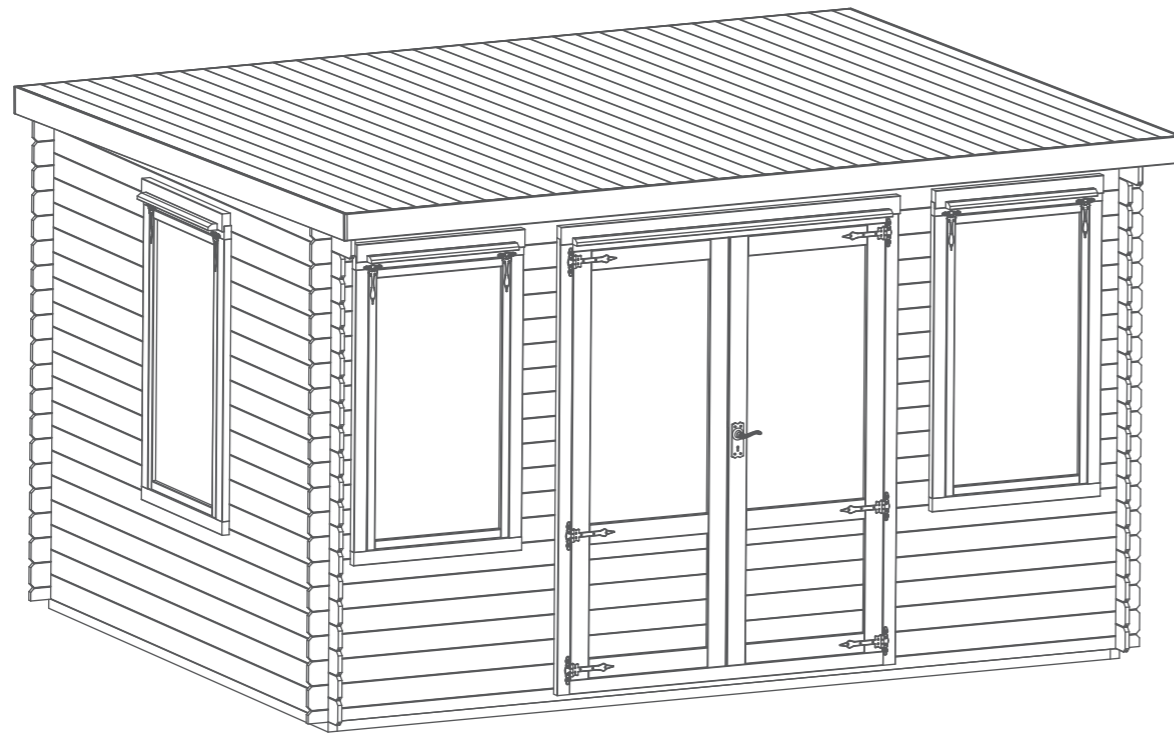

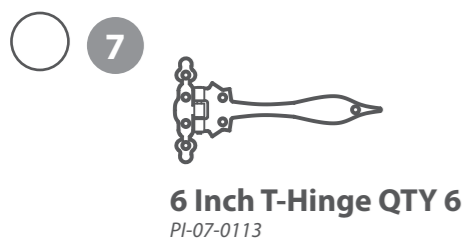
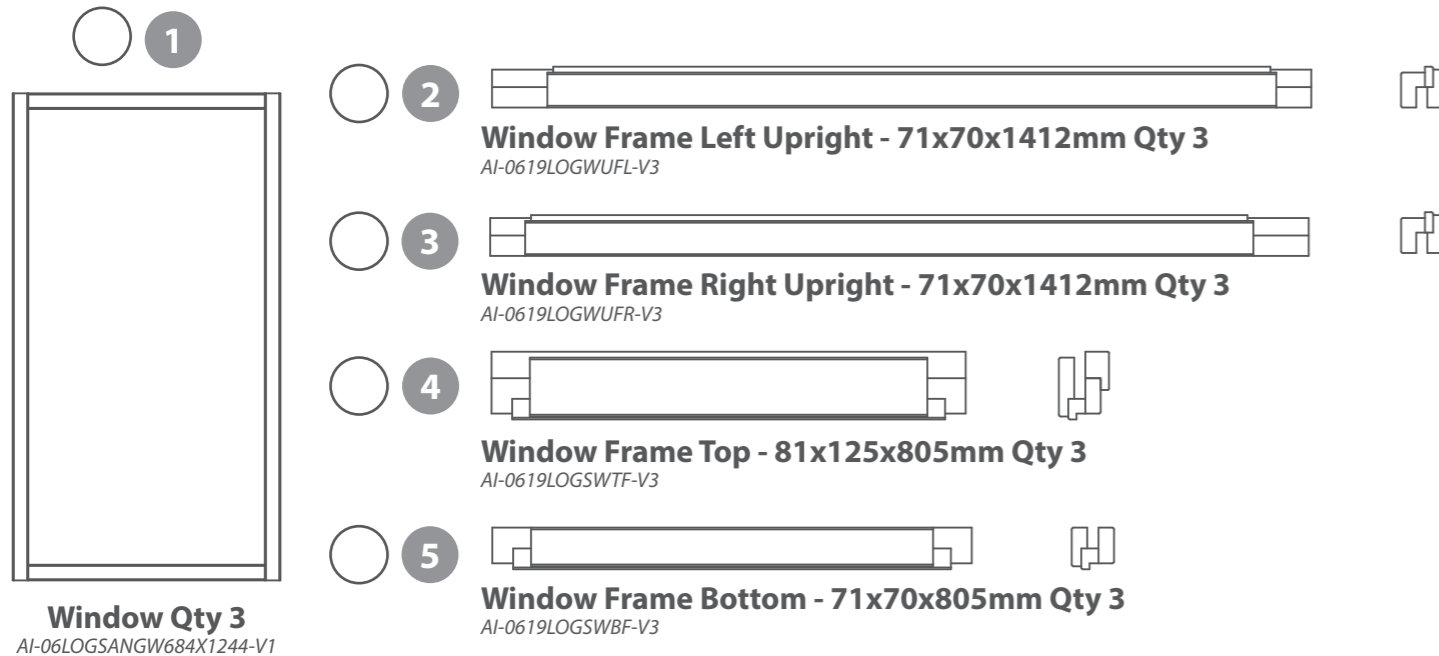

### Window Contents



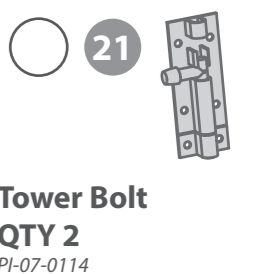
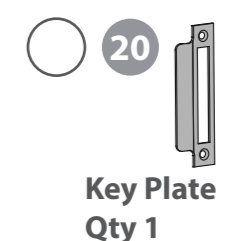
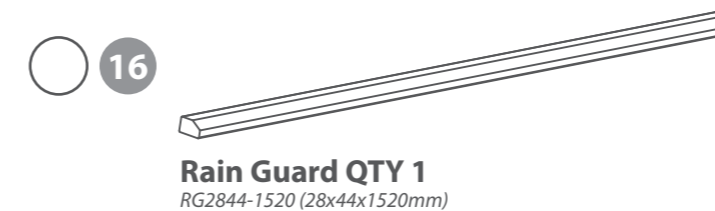
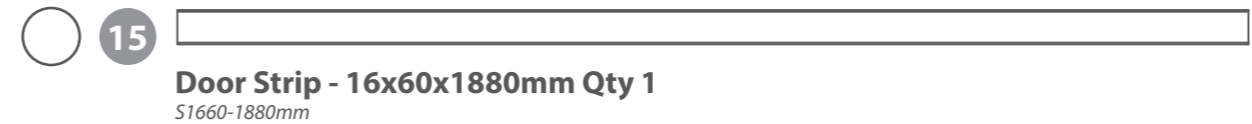
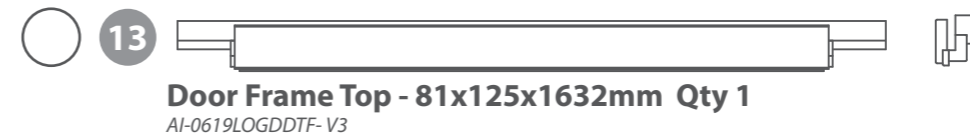
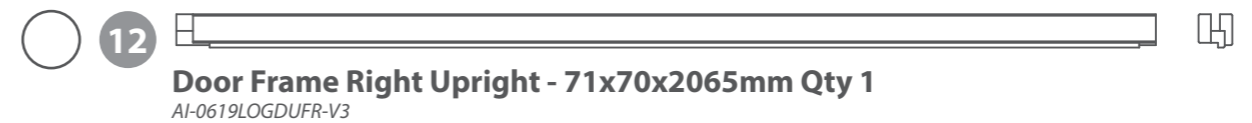
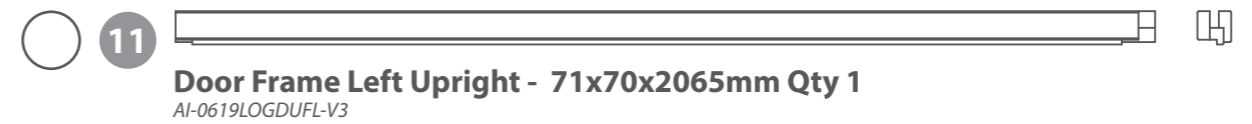
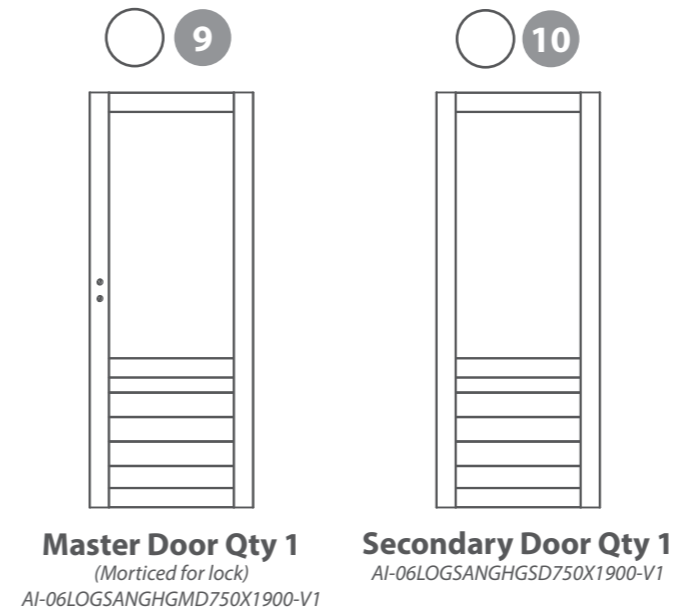

### Double Door Contents





- 

**22** **Bottom Gable QTY 2**  
AI-0619PNNE0403HGDD3SW-G-V1
- 

**23a** **Top Gable A QTY 2**  
AI-0619PNNE0403HGDD3SW-G-V1
- 

**23b** **Top Gable B QTY 2**  
AI-0619PNNE0403HGDD3SW-G-V1
- 

**23c** **Top Gable C QTY 2**  
AI-0619PNNE0403HGDD3SW-G-V1
- 

**24** **Starter Board - 66x19x4000mm QTY 2**  
LB19RT66-A-4000
- 

**25** **Log Board - 120x19x4000mm QTY 20**  
LB19-A-4000
- 

**26** **Log Board - 120x19x2996mm QTY 25**  
LB19-A-2996
- 

**27** **Log Board - 120x19x1123mm QTY 24**  
LB19-B-1123
- 

**28** **Log Board - 120x19x1216mm QTY 12**  
LB19-B-1216
- 

**29** **Log Board - 120x19x232mm QTY 24**  
LB19-B-232
- 

**30** **Log Board - 120x19x232mm QTY 24**  
LB19-C-232
- 

**31** **Log Board - 120x19x4000mm QTY 1**  
LB19-AD-4000 (1 X Double door cut out & Window cut outs)
- 

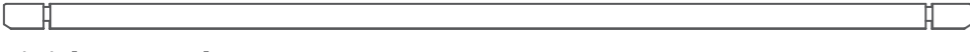
**32** **Log Board - 120x19x2996mm QTY 1**  
LB19-AD-2996 (1 X Window cut out)
- 

**33** **Finisher Board - 54x19x4000mm QTY 1**  
LB19RG54-A-4000
- 

**34** **Finisher Board - 50x19x4000mm QTY 1**  
LB19RG50-A-4000

- 

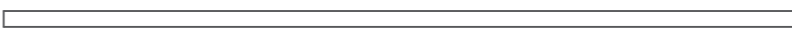
**35** **Roof Purlin - 40x90x4004mm Qty 2**  
F4090-A-4004
- 

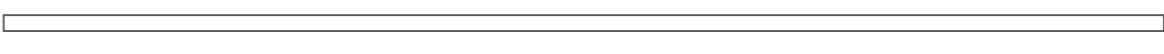
**36** **Bearer - 44x44x2804mm QTY 2**  
F4444-2804-PT
- 

**37** **Bearer - 44x44x3720mm QTY 10**  
F4444-3720-PT
- 

**38** **Fascia - 120x12x4100mm QTY 2**  
S12120-4100
- 

**39** **Fascia - 120x12x3400mm QTY 2**  
S12120-3400
- 

**40** **Roof Board - 121x12x3296mm QTY 37**  
MB12-C-3296
- 

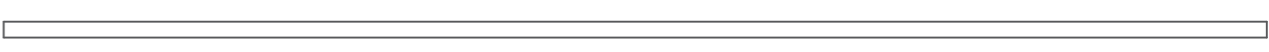
**41** **Floor Board - 121x12x2760mm QTY 35**  
MB16-C-2760
- 

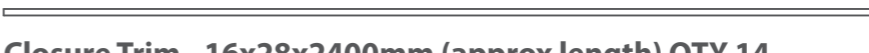
**42** **Eaves Frame - 44x27x4004mm QTY 2**  
F2744-4004
- 

**43** **Closure Trim - 16x28x2400mm (approx length) QTY 14**  
S1628-2400
- 

**44** **Storm Brace - 44x27x2000mm QTY 8**  
F2744-2000
- 

**45** **Felt**
- 

**46** **Roof Spacers QTY 5**  
PI-07-0208 (20x100x2mm)

## Nail Bag

There may be extra screws present in the nail bag

- 

**60mm Bolt Set x 16**
- 

**30mm Screw x 108**
- 

**80mm Screw x 32**
- 

**30mm Black Screw x 128**
- 

**70mm Screw x 70**
- 

**Felt Tacks x 210**
- 

**40mm Screw x 444**

## Pre-assembly

### \*Please note:

Each board interlocks at either end in a staggered pattern.

Before securing ensure that the boards are fitted properly in their respective tongues and grooves.

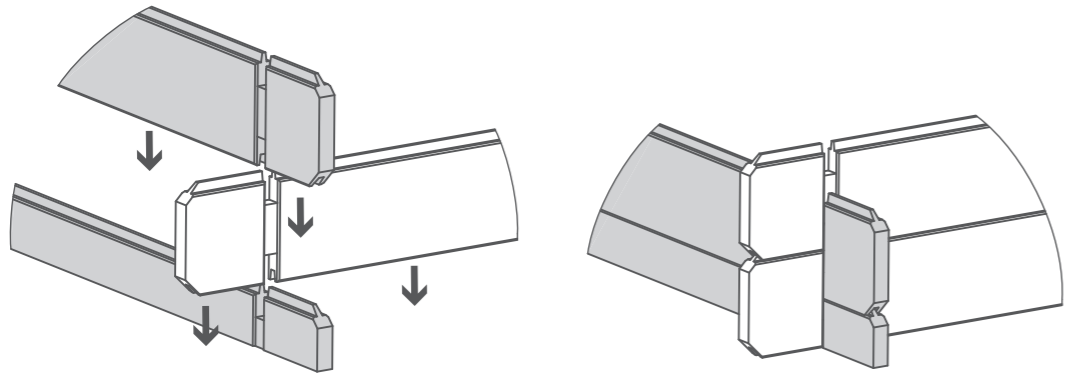

### Step 1

Parts Needed - No. 36 QTY 2  
No. 37 QTY 2

Lay the bearers (No. 36 & 37) onto a firm and level surface (**free from areas where standing water can collect**) as shown in the illustration.

Fix the bearers together at each corner using 2 screws per corner using 8x70mm screws in total, ensuring the bearers are flush.

Once fully assembled, ensure the bearers are square by measuring from corner to corner as illustrated, making sure the measurements are equal.

If the bearers are not aligned equally, unscrew, adjust and re-align accordingly.

8x70mm Screws



70mm screw

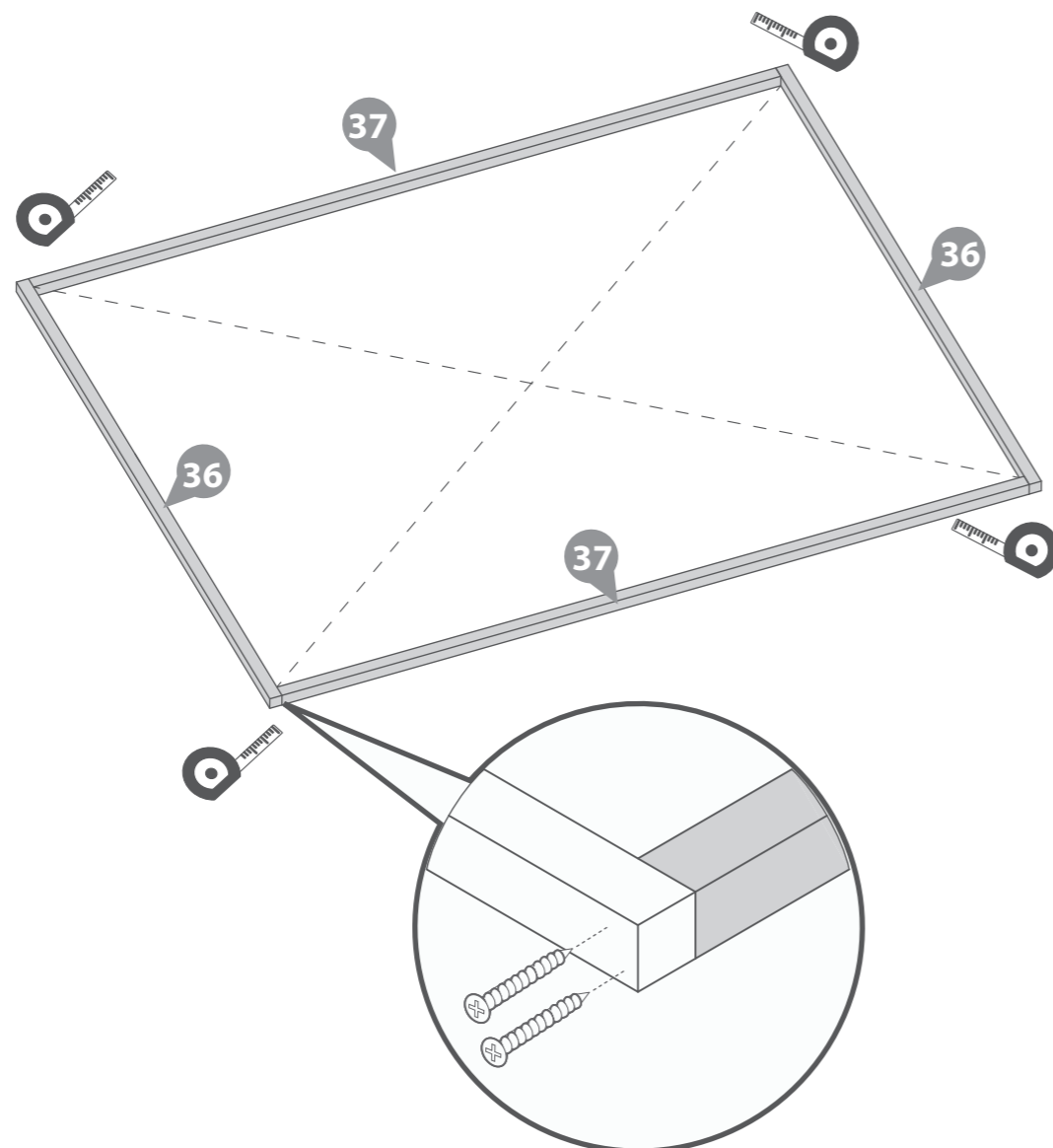

### Step 2

Parts Needed - No. 37 QTY 8

Following the same method arrange the remaining bearers (No. 37) inside the assembled frame.

\*Ensure there is an equal amount of space between each frame.

Secure each of the bearers in place using 2x70mm screws for each side of the bearer, ensuring the bearers remain level.

32x70mm Screws



70mm screw

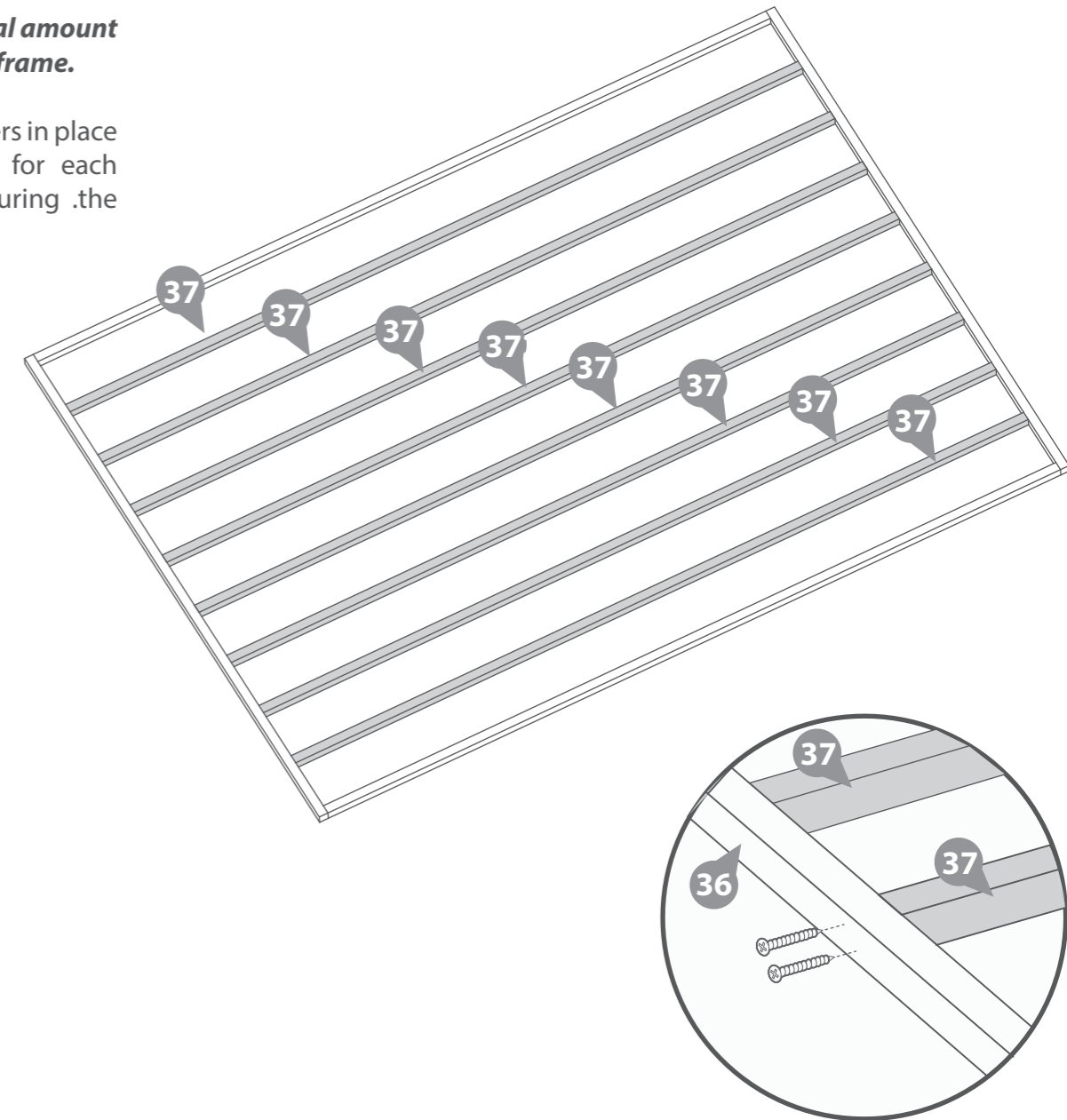

**IMPORTANT: Pre-drill before fixing screws.**

**Step 3**

**Parts Needed - No. 24 QTY 2**  
**No. 26 QTY 2**

**IMPORTANT: Pre-drill before fixing screws.**

Place the starter boards (**No. 24**) on to assembled base frame along the longest sides and place the first two log boards (**No. 26**) in the notch as shown.

Ensure the boards sit square on the base using the same method used in Step 1. Measure corner to corner, making sure the measurements are equal.

Once the boards are square, lift up the log board (**No. 26**) and fix the starter boards in place.

Fix each of the starter boards to the frame by screwing through the notch into the frame as shown in the illustration.

**4x70mm Screws**

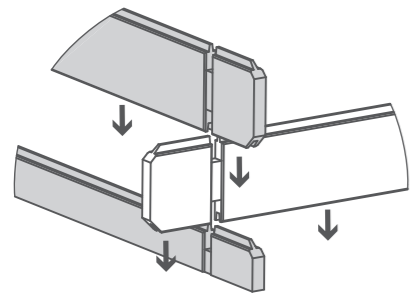
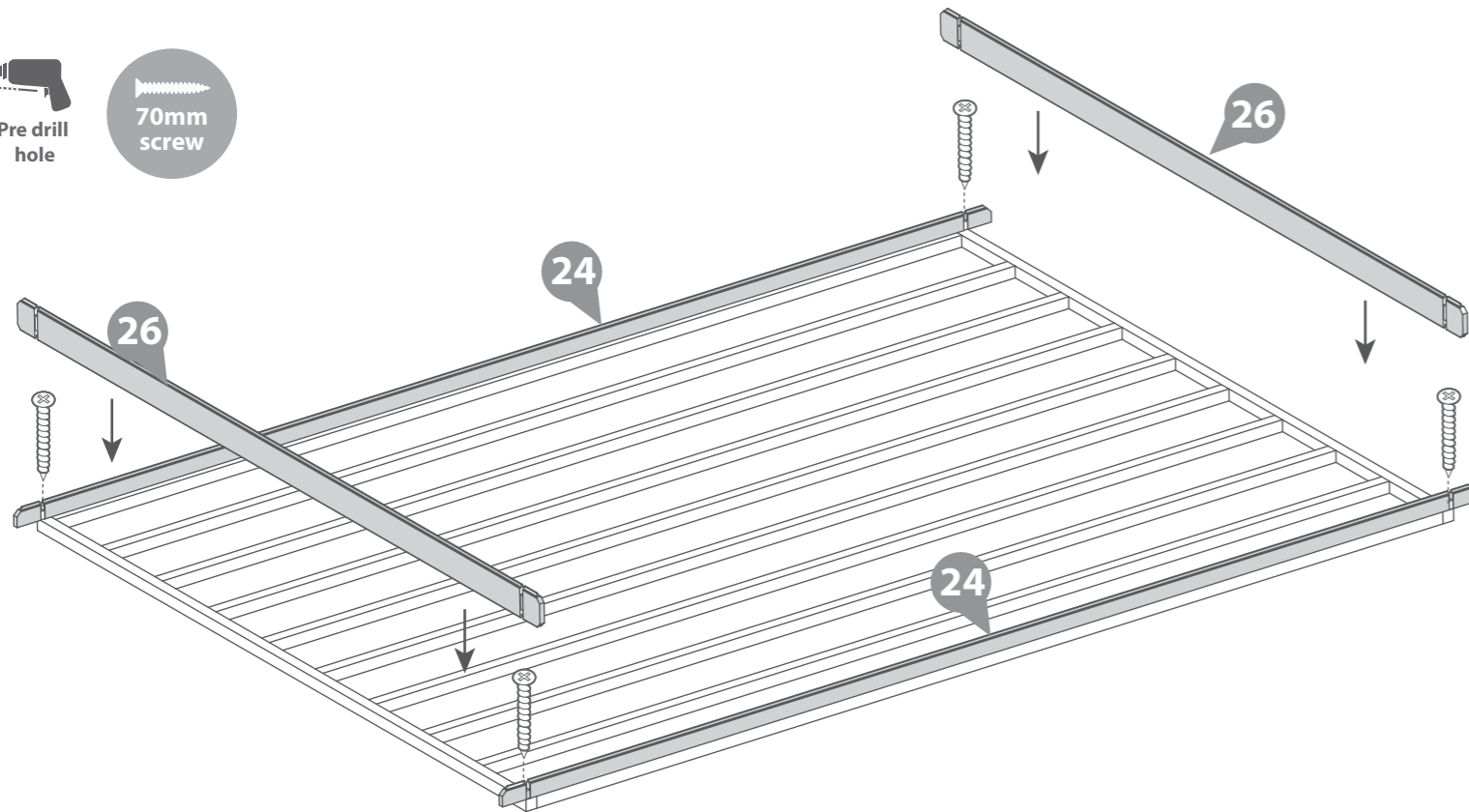
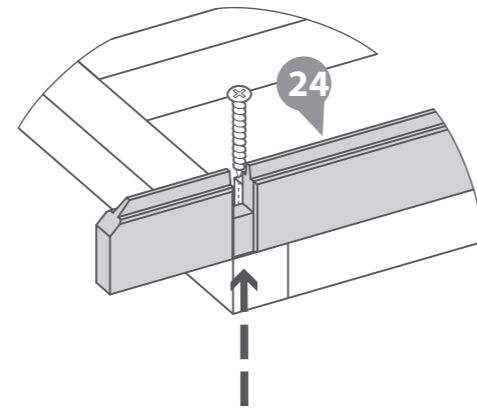

**Step 4**

**Parts Needed - No. 25 QTY 6**  
**No. 26 QTY 10**  
**No. 28 QTY 12**

Following the method shown in the illustration, lay the first 6 boards (**No. 25, 26, & 28**)

Start by placing the front and back boards, interlocking them with the side boards. Then place the next side boards, interlocking with the front and back boards. Continue this method until you have placed **6 boards off of the starter boards on each side**, as shown in the illustration.

This will create your first level.

**\*Ensure that the boards are level and flush with each other as you lay each one.**

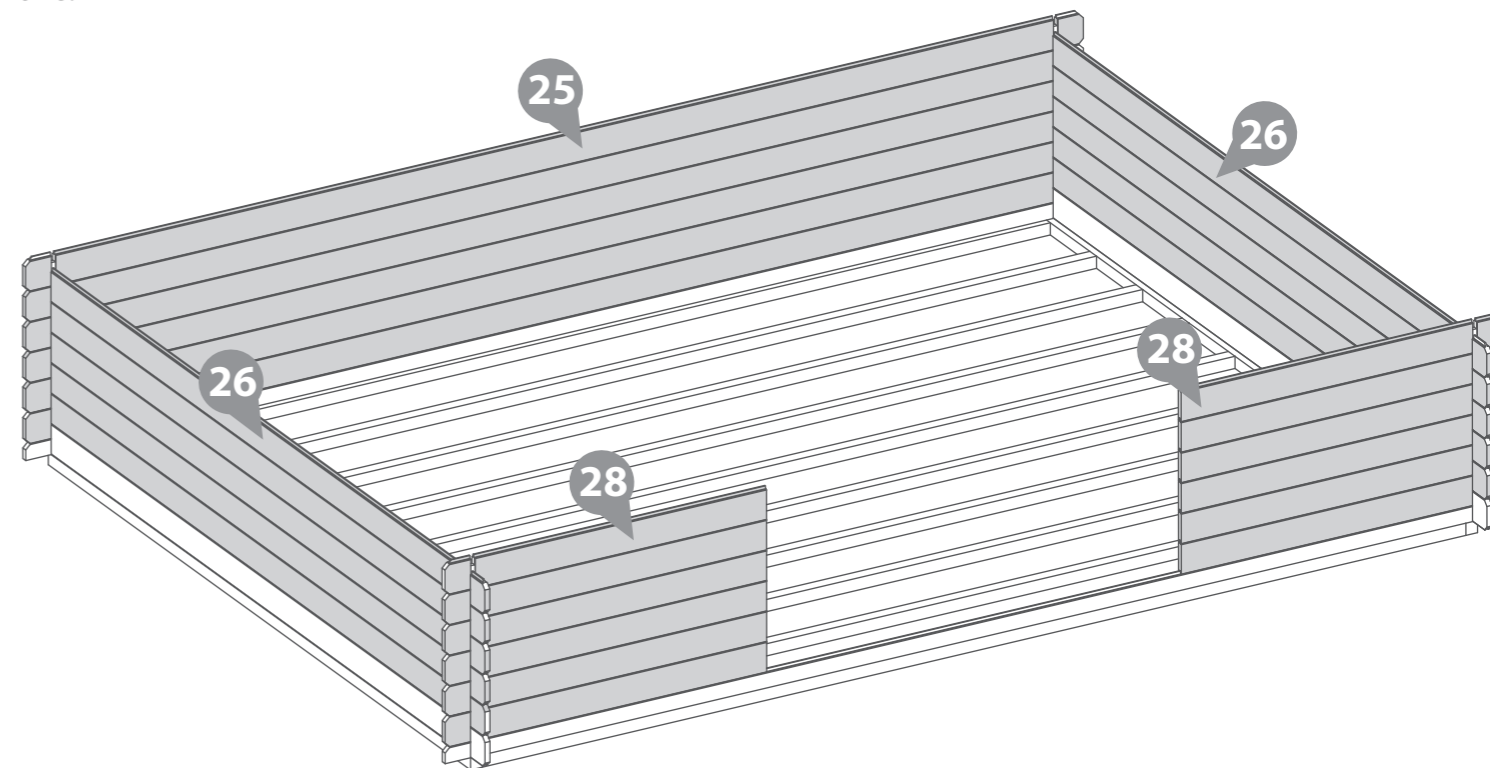
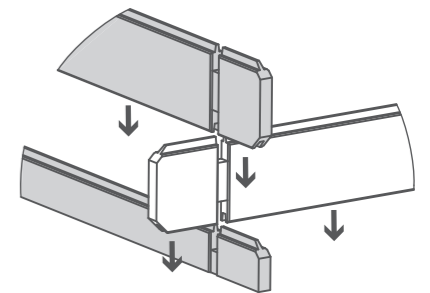

**Step 5**

- Parts Needed -** No. 11 QTY 1  
 No. 12 QTY 1  
 No. 13 QTY 1  
 No. 14 QTY 1

Arrange the left, right, top & bottom door frames (**No's. 11, 12, 13 & 14**) onto a level surface. Secure the top and bottom frames to the uprights using 2x80mm screw per corner, ensuring the screws do **NOT** protrude through the front of the door framing.

**IMPORTANT : Pre-drill before fixing screws.**

**8x80mm Screws**

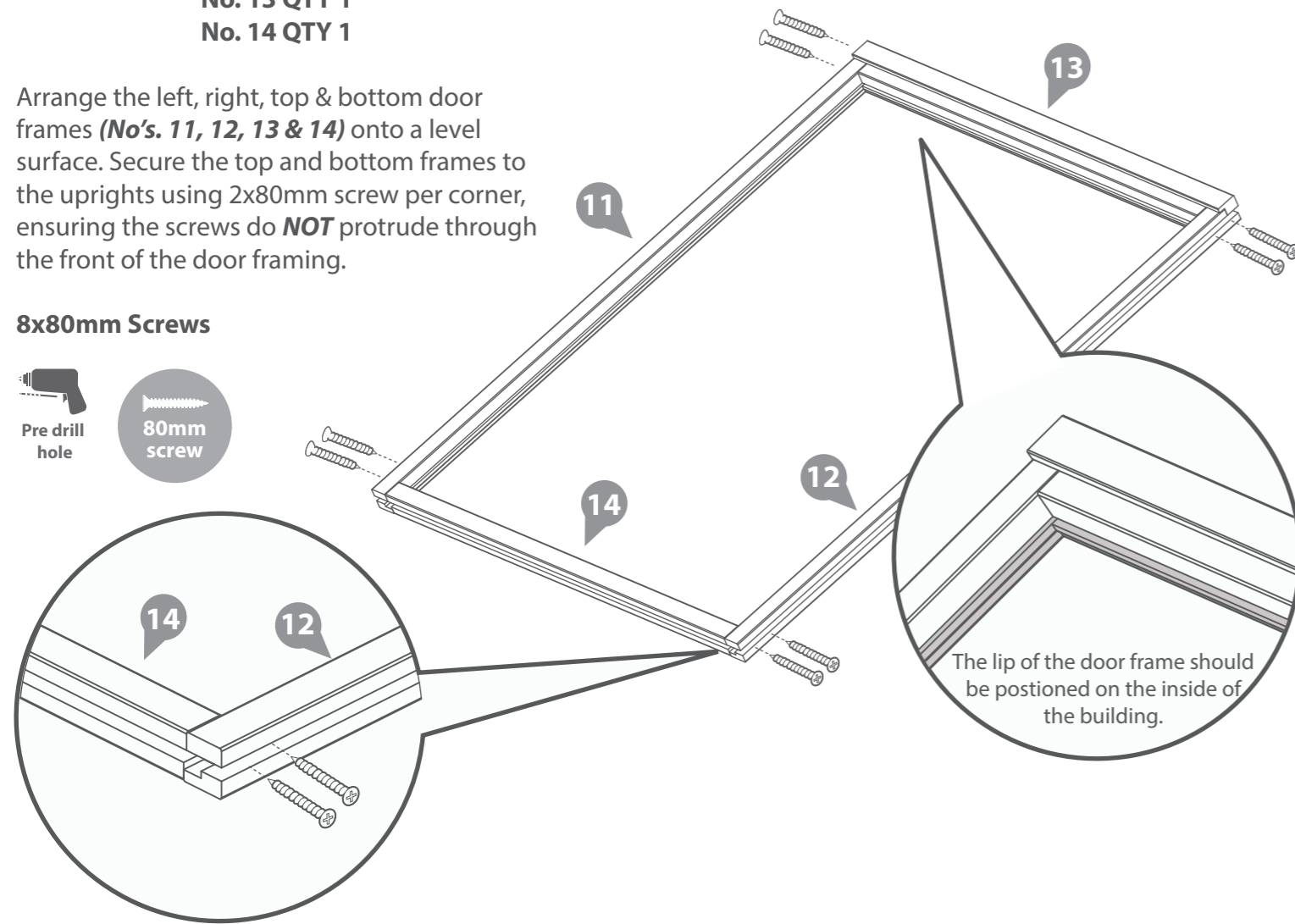
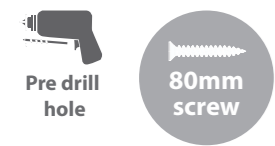

**Step 6**

Once you have laid 6 log boards (off of the starter) up the door section, slide the assembled door frame over the boards resting the frame on top of the starter board (**if you have not yet assembled the door frame refer to step 5**)

**\*Please note:** This image is for illustrative purposes and may differ from your choice in product (**regarding door position**). Nevertheless the process of fitting the door frame is the same.

**\*\*Please Note:** The short boards at the front of the building (either side of the door and window opening's) can be placed either side depending on your needs.

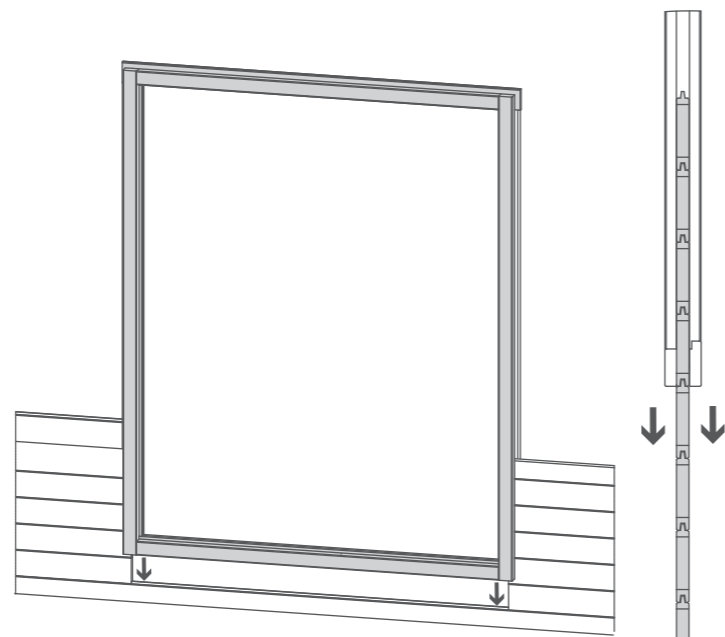

**Step 7**

- Parts Needed -** No. 25 QTY 6  
 No. 26 QTY 6  
 No. 27 QTY 12  
 No. 29 QTY 12  
 No. 30 QTY 12

Following the method shown in the illustration, lay the next 6 boards (**No. 25, 26, 27, 29 & 30**) onto the log cabin to create your second level.

**\*Ensure that the boards are level and flush with each other as you lay each one.**

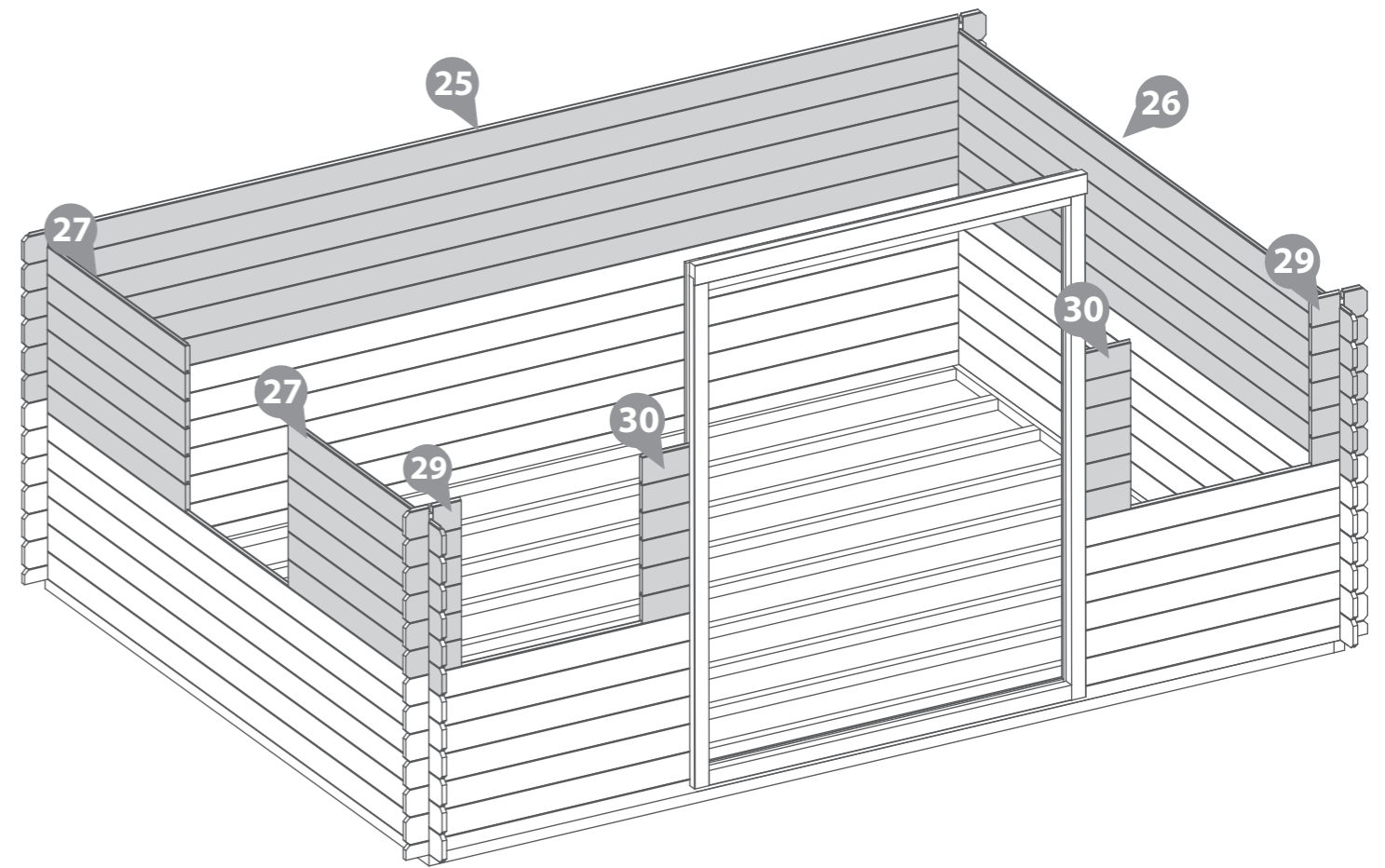
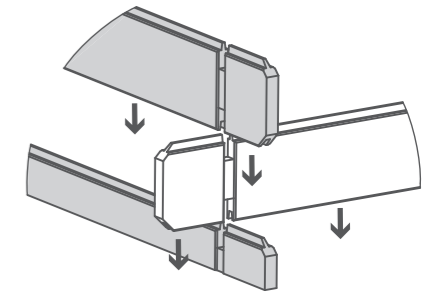

**IMPORTANT : Pre-drill before fixing screws. Step 9**

**Step 8**

- Parts Needed - No. 2 QTY 3**  
**No. 3 QTY 3**  
**No. 4 QTY 3**  
**No. 5 QTY 3**

Arrange the left, right, top & bottom window frames (No's. 2, 3, 4, & 5) onto a firm and level surface. Secure the top and bottom frames to the uprights using 2x80mm screw per corner, ensuring the screws do **NOT** protrude through the front of the window framing.

Use this method to construct 3 window frames.

**24x80mm Screws**

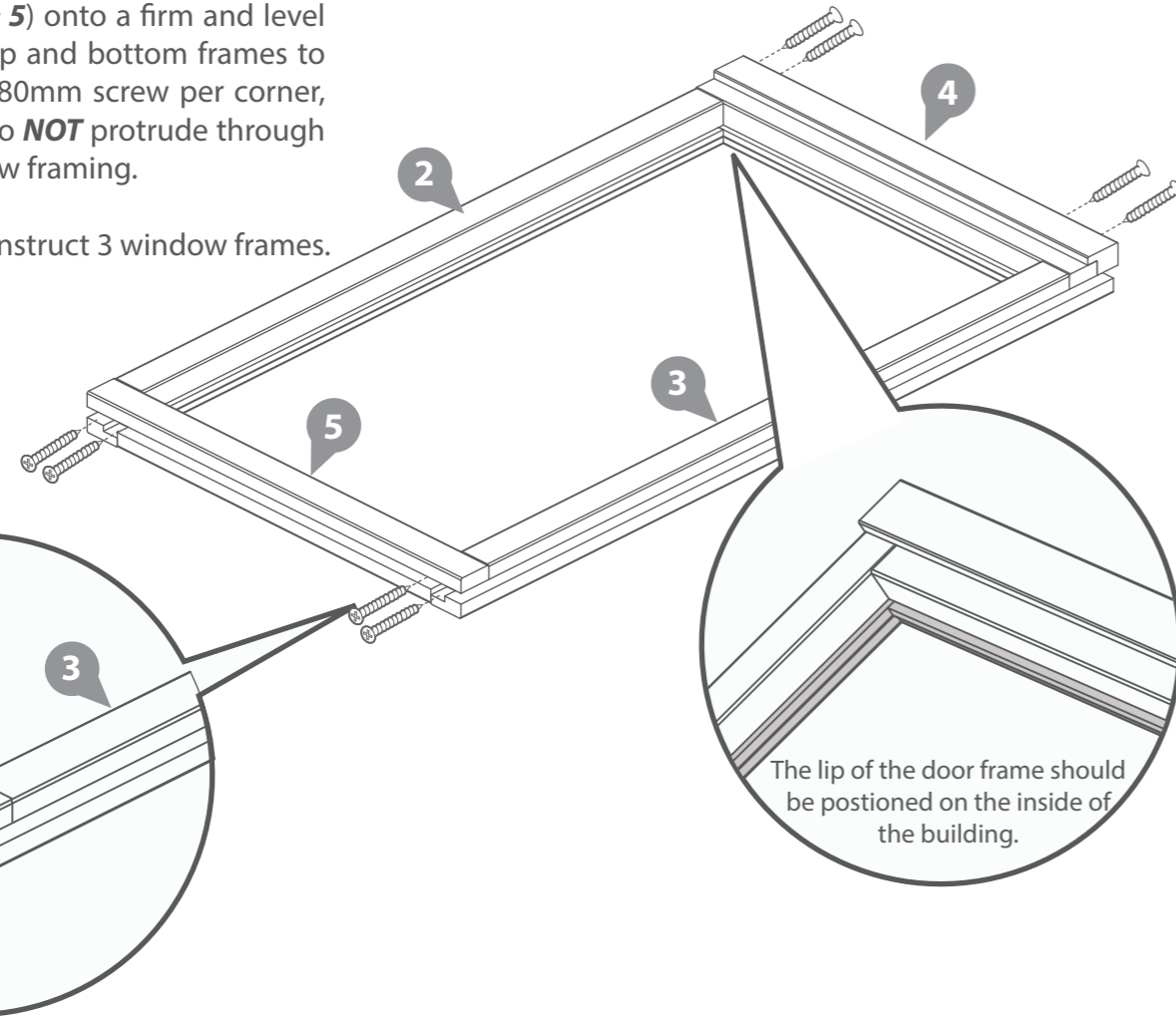

The lip of the door frame should be positioned on the inside of the building.

Once you have laid the second level of boards onto the log cabin slide the windows between the smaller boards and rest on to the longer board (**if you have not yet assembled the window frames refer to step 8**)

**\*Ensure the boards are level with each end.**

**\*Please note:** This image is for illustrative purposes and may differ from your choice in product (**regarding window position**).

Nevertheless the process of fitting the window is the same

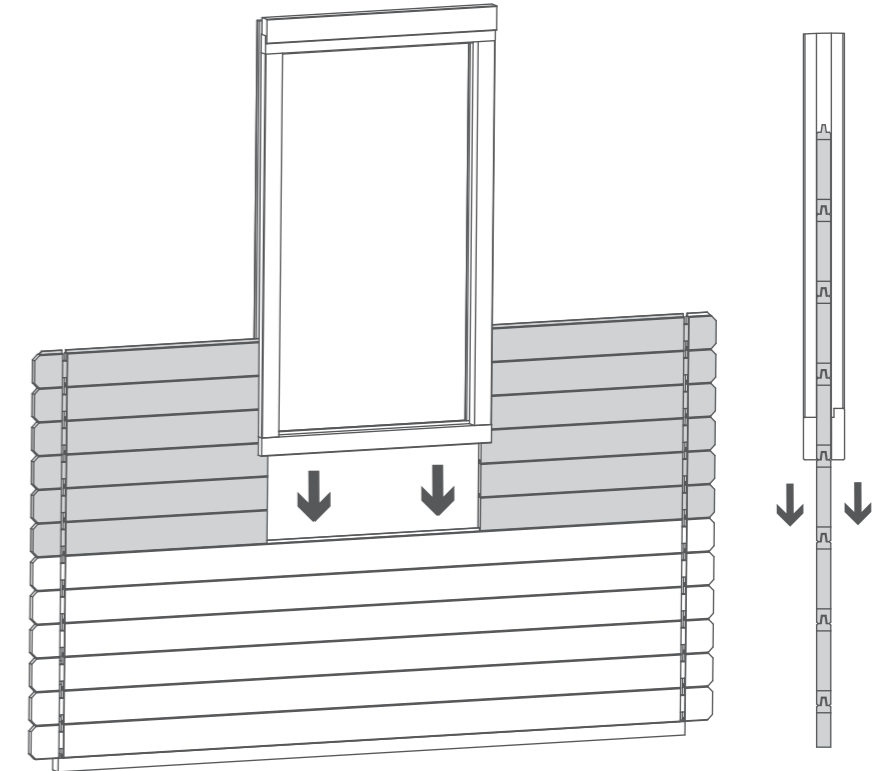

**Step 10**

- Parts Needed - No. 25 QTY 6**  
**No. 26 QTY 6**  
**No. 27 QTY 12**  
**No. 29 QTY 12**  
**No. 30 QTY 12**

Following the method shown in the illustration, lay a further 6 boards (No.25, 26, 27, 29 & 30) onto the log cabin to bring the board level to the top of the window and door frames.

**\*Ensure that the boards are level and flush with each other as you lay each one.**

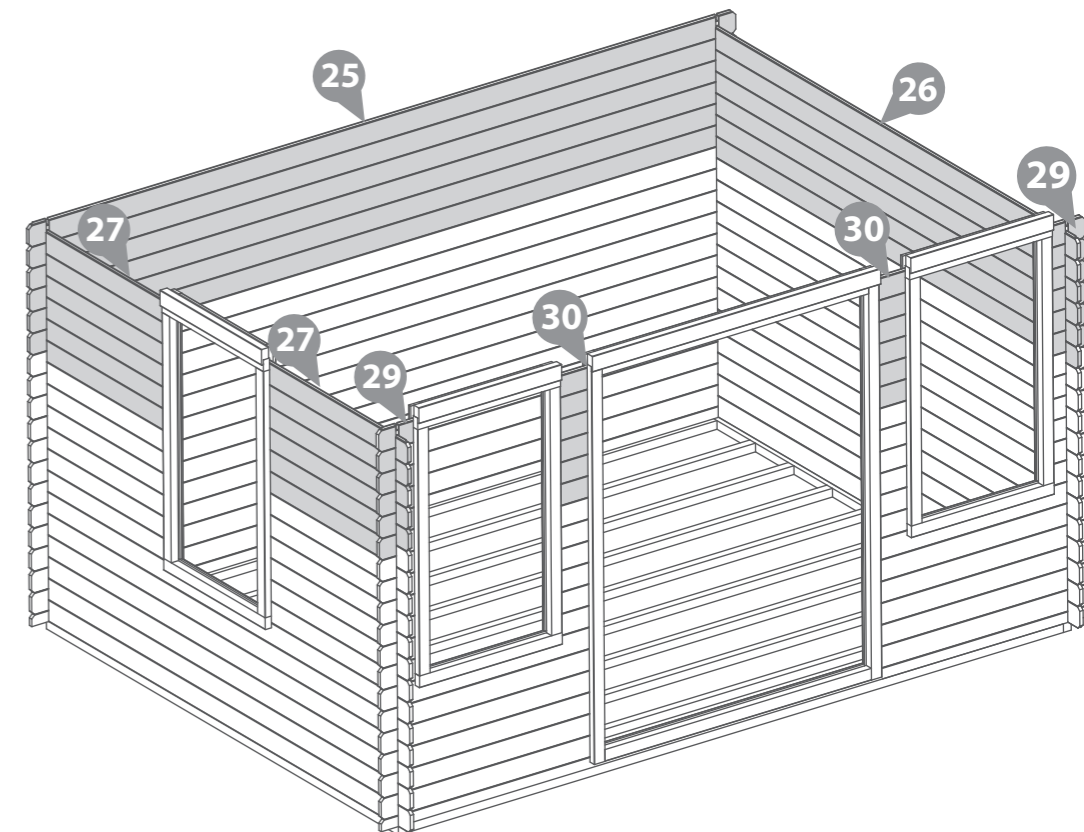
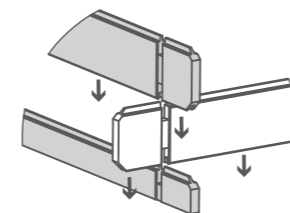

**Step 11**

- Parts Needed - No. 25 QTY 1**  
**No. 26 QTY 1**  
**No. 31 QTY 1**  
**No. 32 QTY 1**

Following the method shown in the illustration, lay the next two boards (**No. 26 & 32**) on the window and opposite plain side.

Once in position, place the next two boards (**No. 25 & 31**) onto the door and rear sides.

**\*Ensure that the boards are level and flush with each other as you lay each one.**

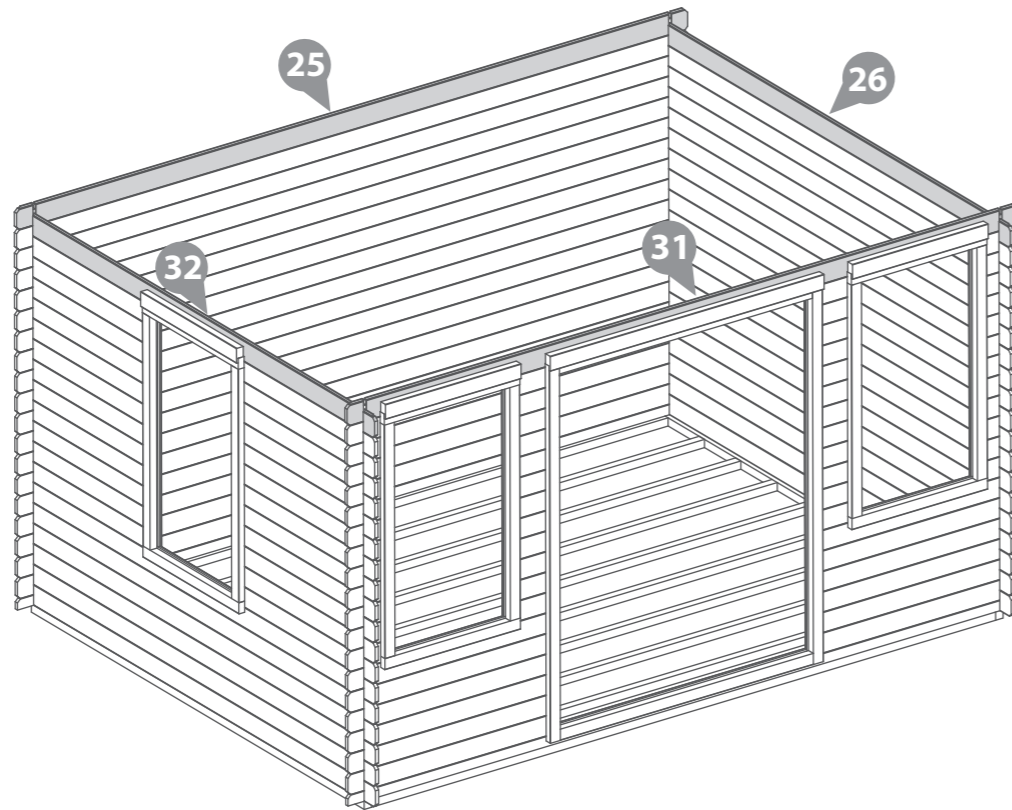

Rubber Mallet may be required to fit parts.

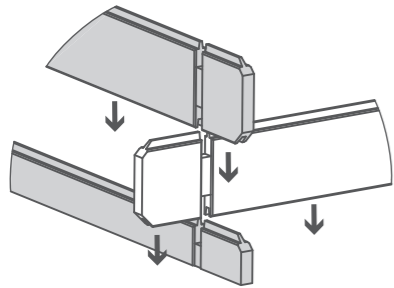

**Step 12**

- Parts Needed - No. 22 QTY 2**  
**No. 25 QTY 1**  
**No. 34 QTY 1**

Following the method shown in the illustration, place the first boards from the gable (**No. 22**) and the remaining Log board (**No.25**) and Finisher Board (**No. 34**) onto the log cabin,

**\*Ensure that the boards are level and flush with each other as you lay each one.**

Fix each board to the one below by screwing through the notch as shown in the illustration using 1x70mm screw per corner.

**\*\*Ensure to stagger the screws so as not to collide with the previous screw.**

**4x70mm Screws**



Pre drill hole



70mm screw



Rubber Mallet may be required to fit parts.

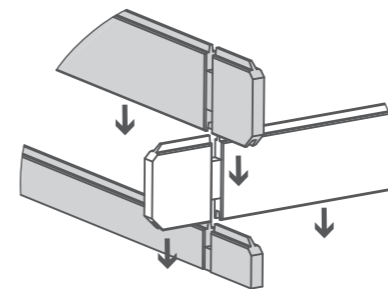

**IMPORTANT : Pre-drill before fixing screws.**

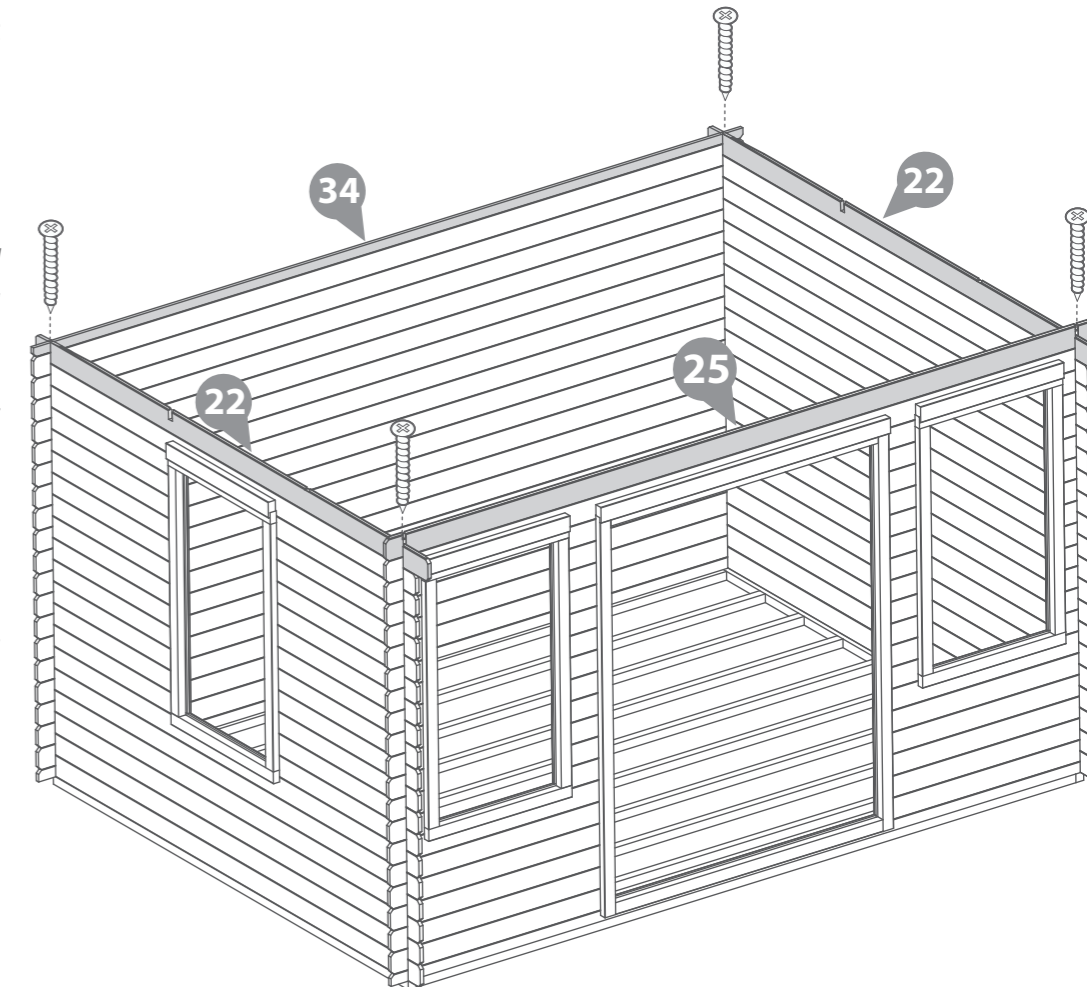

### Step 13

- Parts Needed - No. 23a QTY 2  
 No. 23b QTY 2  
 No. 23c QTY 2  
 No. 33 QTY 1

Following the method shown in the illustration, place Gable Top A (No.23a), Gable Top B (No.23b), Gable Top C (No.23c) and the Finisher Board (No. 33) onto the log cabin.

**\*Ensure that the boards are level and flush with each other as you lay each one.**

Fix the log board (No.33) and Front Gable A (No.22a) to the board below by screwing through the notch using 1x70mm screw per corner, as shown in the illustration

Fix Top Gable C (No.23c) in place by screwing through the board into the one below using 1x30mm screw per side as shown in the illustration.

**\*\*Ensure to stagger the screws so as not to collide with the previous screw.**

- 2x70mm Screws  
 2x30mm Screws

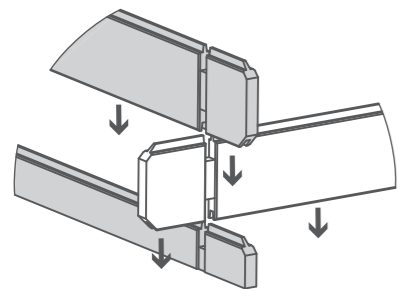
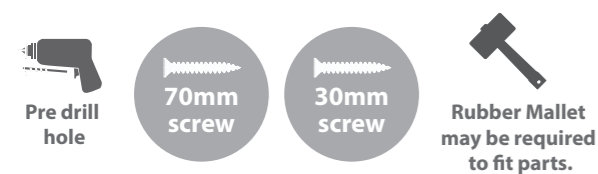

**IMPORTANT : Pre-drill before fixing screws.**

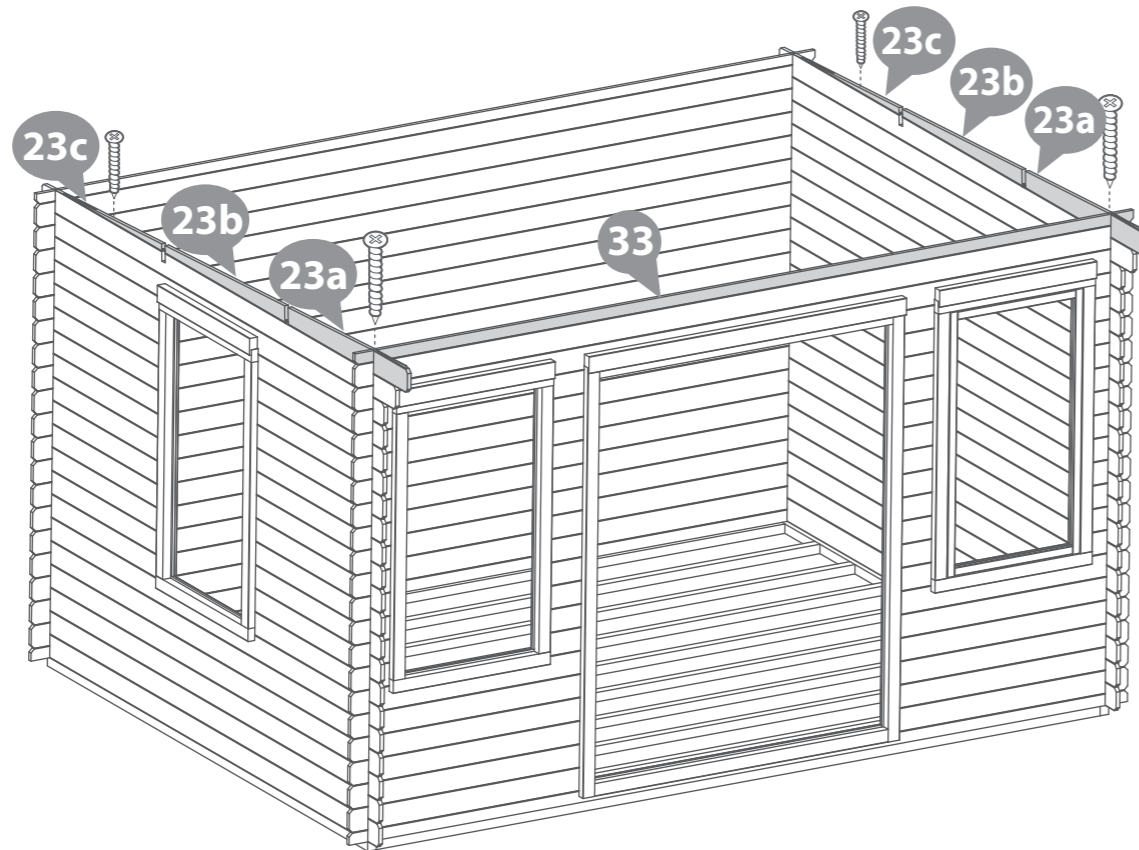

### Step 14

- Parts needed - No. 35 QTY 2

**a** Align the Roof Purlin (No. 35) into the cut out slots on each gable top ensuring they interlock.

**b** Secure the roof purlin at each end by screwing through the bars into the boards (**ensure to pre-drill to avoid the boards splitting**) using 4x70mm screws per purlin.

**\*Please note:** The gable shown is for illustrative purposes and may differ in width from your choice in product. Nevertheless, despite any differences the process of fixing the purlins is the same.

- 8x70mm Screws

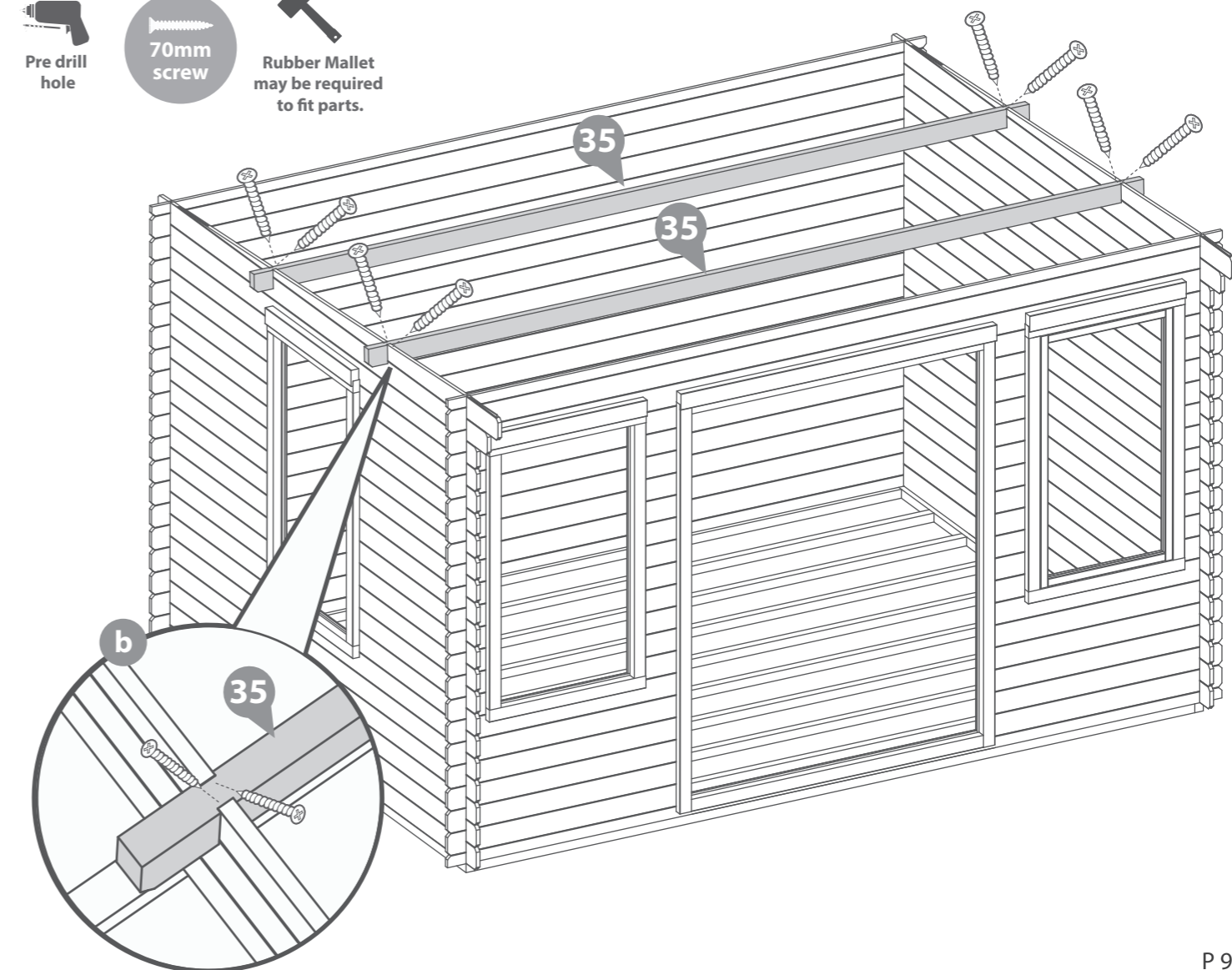
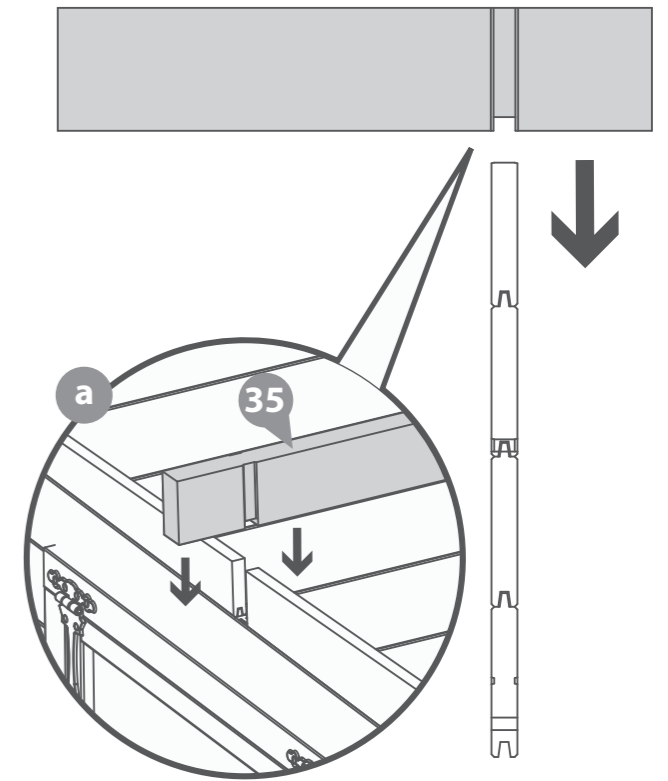
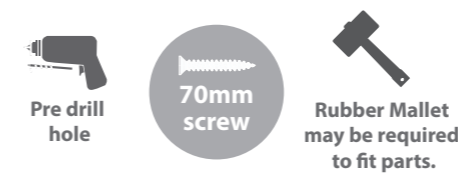

**Step 15**

**Parts needed - No. 40 QTY 37**

**a** Place the first roof board (**No. 40**) onto the log cabin, making sure the boards are flush to the end of the roof purlin. Ensure there is an even amount of overhang between the log boards and roof board at the front and back of the cabin.

Once in position fix to the purlin, front and back of the log cabin using 4x40mm screws.

Ensure the roof boards are not laid too close together, use the spacers (**No. 46**) provided to create a 2mm gap. Adjusting the spacing between the boards allows the wood to swell in damp weather.

Continue to place the roof boards onto the roof, ensuring each roof board is interlocked and level. Once in position fix the roof boards to the purlin, front and back of the log cabin using 4x40mm screws per roof board.

**\*Please Note:** The Purlin will be longer than the log boards by 2mm each end.

You have been issued with 37 roof boards, but in reality you may only need to use 36.

**b** The last roof board will overhang past the end of the roof purlin. Using a straight edge and a pencil, mark out a line as a guide.

Cut along the pencil mark and remove the excess. Place the cut down board's back onto the roof and secure into place using 4x40mm screws per board.

**\*Please Note:** This image is for illustrative purposes and may differ from your choice in product. Nevertheless the process of cutting and fitting the last roof board(s) is the same.

**148x40mm Screws**



**IMPORTANT : Pre-drill before fixing screws.**

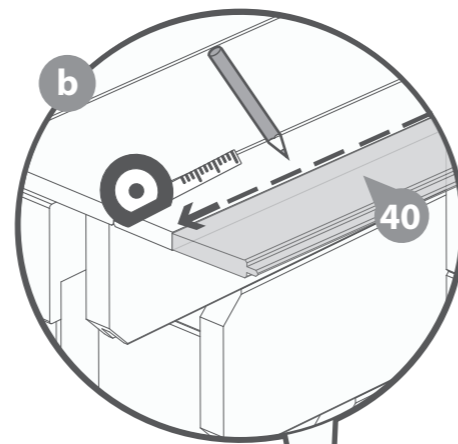

**Step 16**

**Parts Needed - No. 42 QTY 2**

Ensuring the roof boards are flush at the overhanging side, fix the eaves frames (**No. 42**) to the underside of the roof boards using 9x30mm screws as shown in the illustration

**\*Please Note:** This image is for illustrative purposes and may differ from your choice in product. Nevertheless the process of fixing the eaves frames is the same.

**18x30mm Screws**



**IMPORTANT : Pre-drill before fixing screws.**

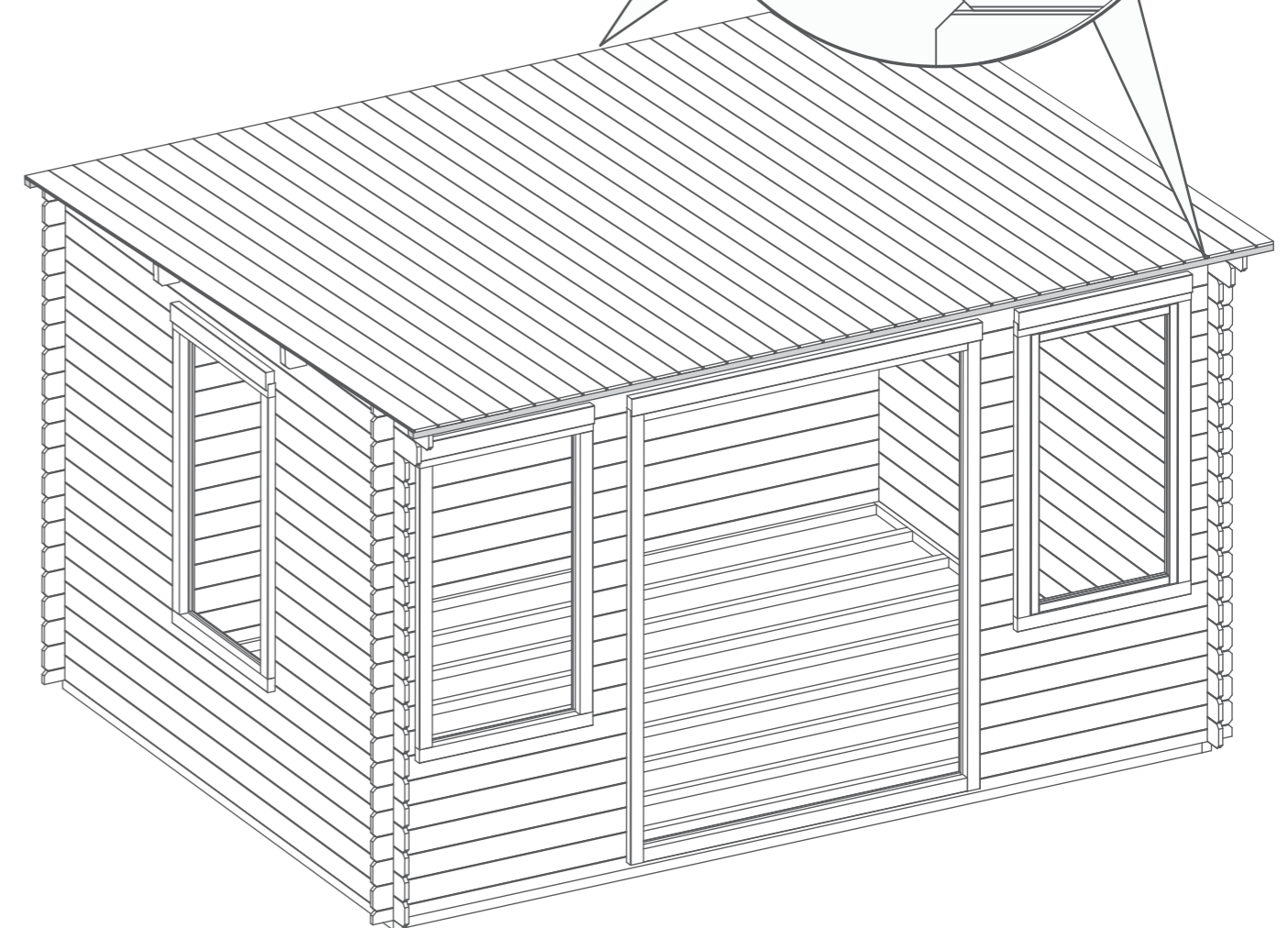
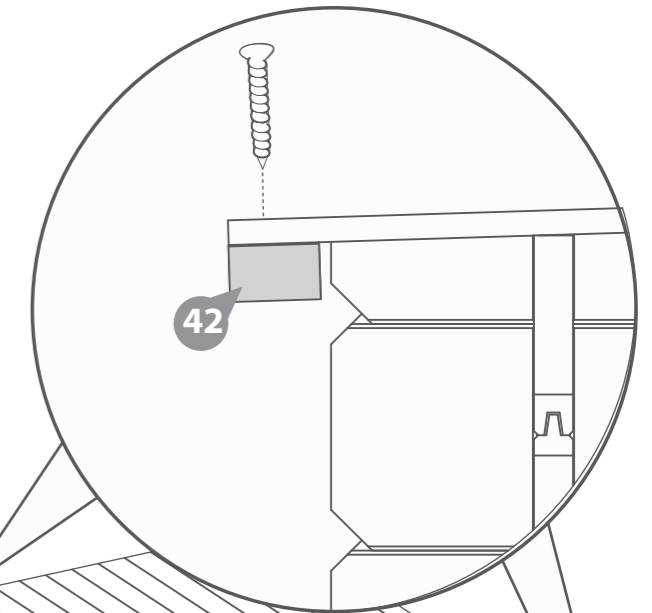

**Step 17**

**Parts Needed - No. 1 QTY 1  
No. 7 QTY 2**

Place the window (**No. 1**) onto a flat surface and fix 2xT-hinges (**No. 7**) to the window using 3x30mm black screws per hinge.

Locate the window into the window frame on the cabin, ensuring there is equal spacing on each side between the window and window frame.

Secure into position by screwing through the T-hinges (**No. 7**) using 5x30mm black screws per hinge.

**\*Ensure to screw into the framing and not into the channel.**

Use this method to assemble 3 windows.

**48x30mm Black Screws**

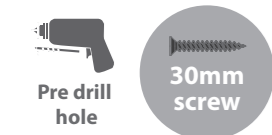

**IMPORTANT : Pre-drill before fixing screws.**

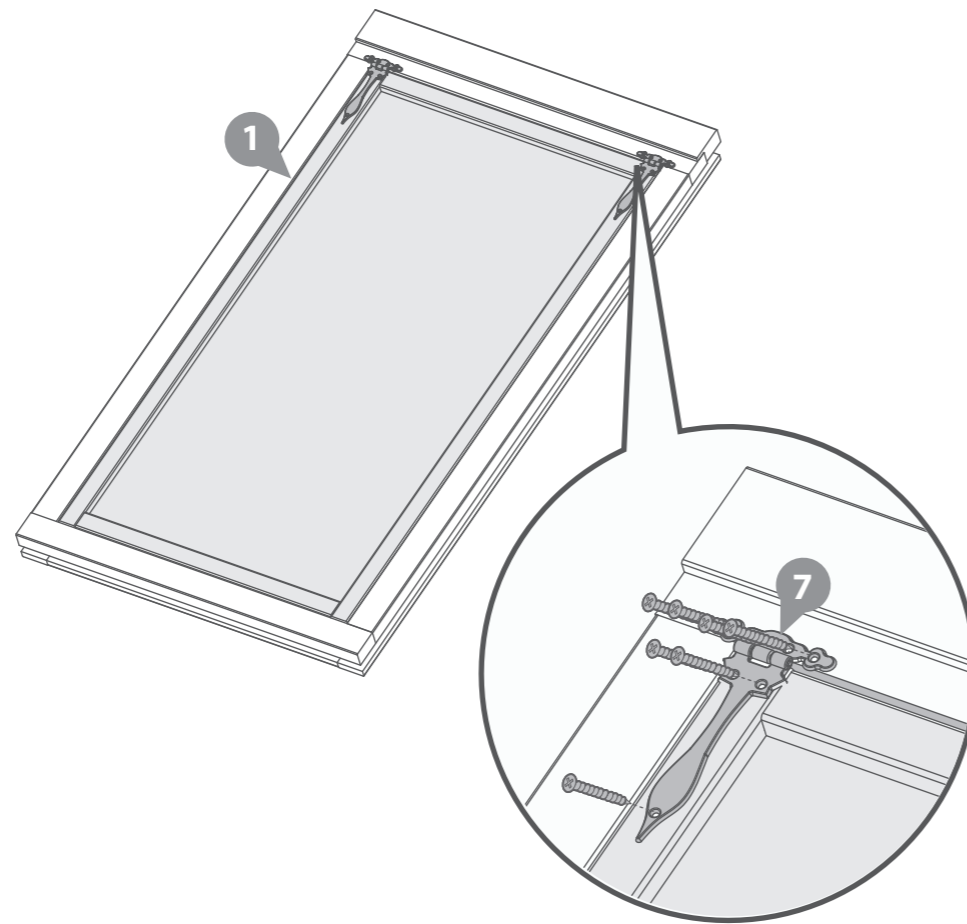

**Step 19**

**Parts Needed - No. 9 QTY 1  
No. 10 QTY 1  
No. 17 QTY 6**

**Once the roof is fixed**, place the master and secondary doors (**No's 9 & 10**) onto a flat surface and fix 3x9 inch T-hinges (**No.17**) to each door using 5x30mm black screws per hinge.

Locate the doors into the door frame on the cabin, ensuring there is equal spacing on each side between the doors and door frame.

Secure into position by screwing through the T-hinges (**No.17**) using 4x30mm black screws per hinge, making sure the doors open & close freely without restriction

**\*Ensure to screw into the framing and not into the channel.**

**54x30mm Black Screws**

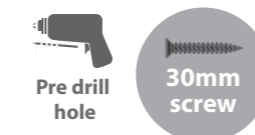

**IMPORTANT : Pre-drill before fixing screws.**

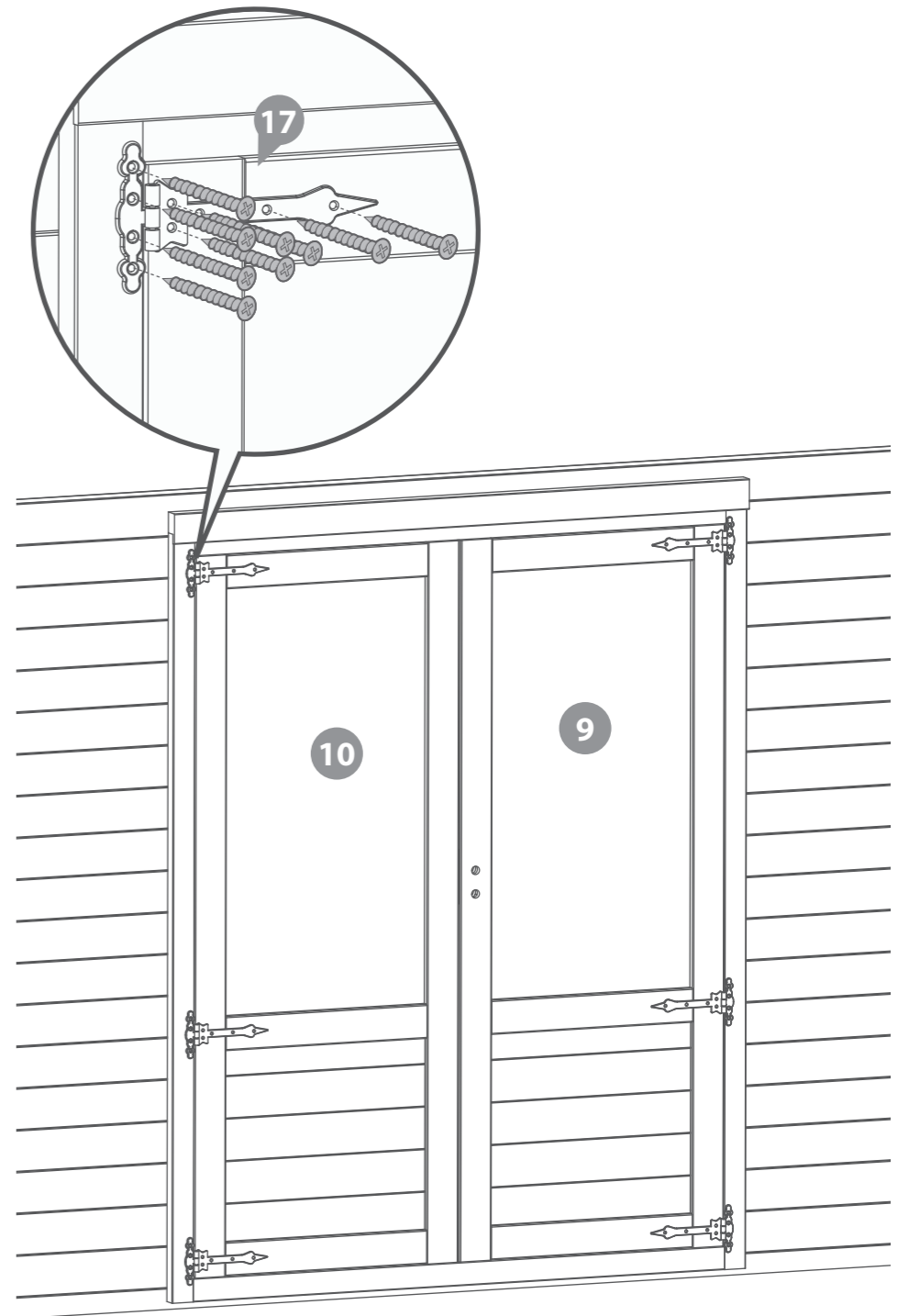

**Step 18**

**Parts Needed - No. 8 Qty 1**

Fix the casement stay (**No. 8**) onto the window (**No. 1**) and the casement stay pins to the window framing using 6x30mm black screws.

**\*Ensure the casement stay is centralised on the window.**

Use this method to fit one casement stay to each window.

**18x30mm Black Screws**

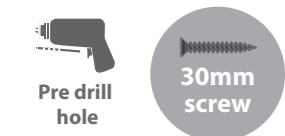

**IMPORTANT : Pre-drill before fixing screws.**

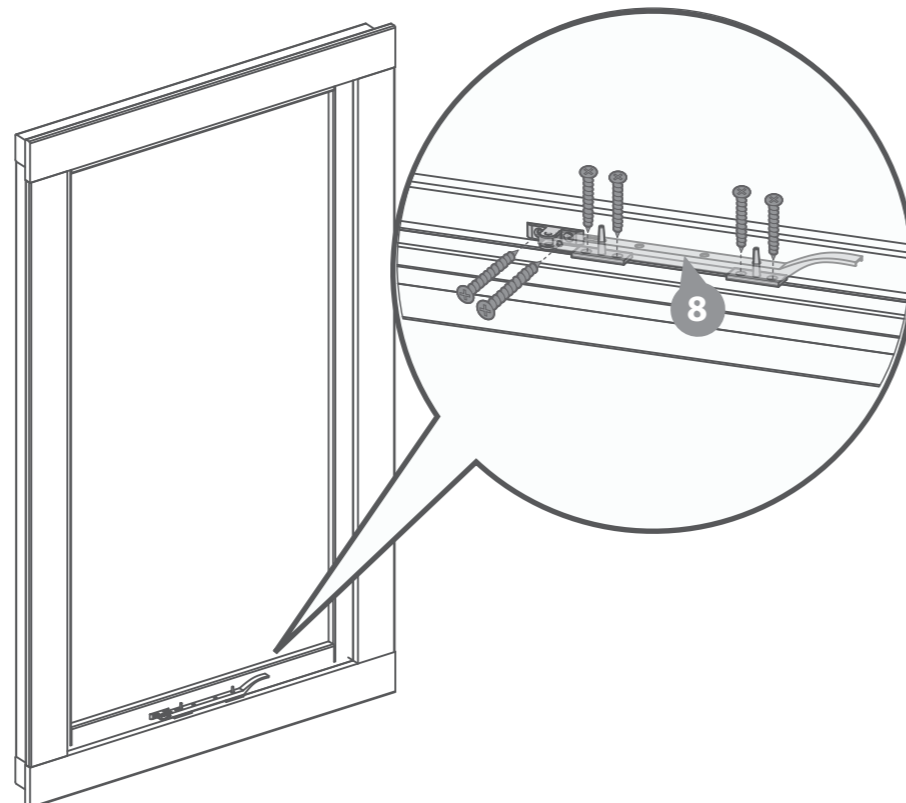

**Step 20**

**Parts Needed - No. 18 QTY 1  
No. 19 QTY 1  
No. 20 QTY 1**

**IMPORTANT : Pre-drill before fixing screws.**

**a** Fit the Mortice Lock (**No. 19**) into the recess in the master door (**No. 9**) and secure using the screws provided. Attach the Key Plate (**No. 20**) to the secondary door (**No. 10**) with 4x30mm screws.

**b** Fit the Door Handles (**No. 18**) and connect with the metalbar to the mortice lock using 8x30mm black screws. Ensure the lock mechanism closes correctly. If not, remove the lock and turn the catch around using the small grub screw.

*\*Please note: This image is for illustrative purposes and may differ from your choice in product (regarding ironmongery). Nevertheless the process of fixing the frames is the same.*

**8x30mm Black Screws  
4x30mm Screws**

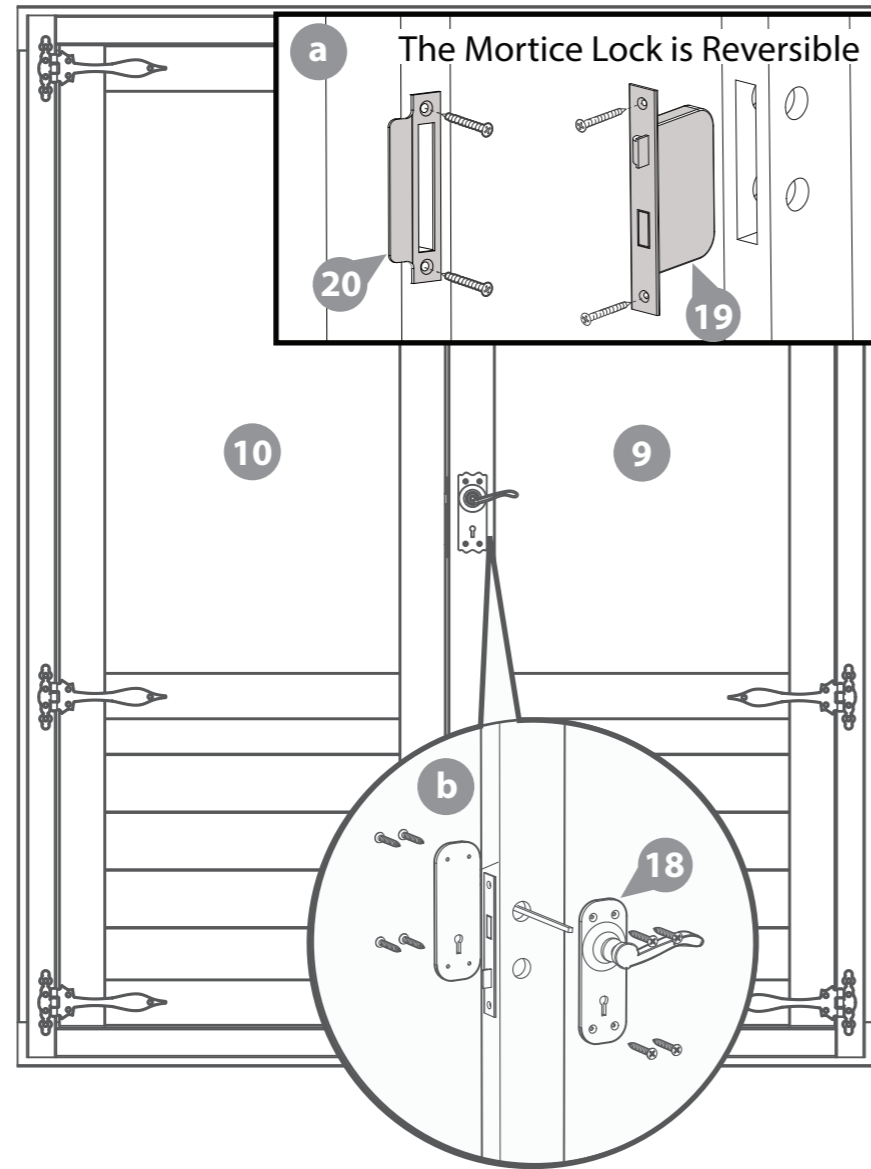

**Step 21**

**Parts Needed - No. 15 QTY 1  
No. 21 QTY 2**

**IMPORTANT : Pre-drill before fixing screws.**

Attach the Door Strip (**No. 15**) to the back of the secondary door using 4x40mm screws as shown.

**a** Once fixed, place the Tower Bolts (**No. 21**) roughly into position at the top and bottom of the door strip. With a pencil mark the around the bolt.

**b** After marking the bolt onto the frame, drill a hole for the barrel bolt to locate into.

**c** Following the hole being drilled, place the tower bolts into position and secure using the screws provided.

**4x40mm Screws**

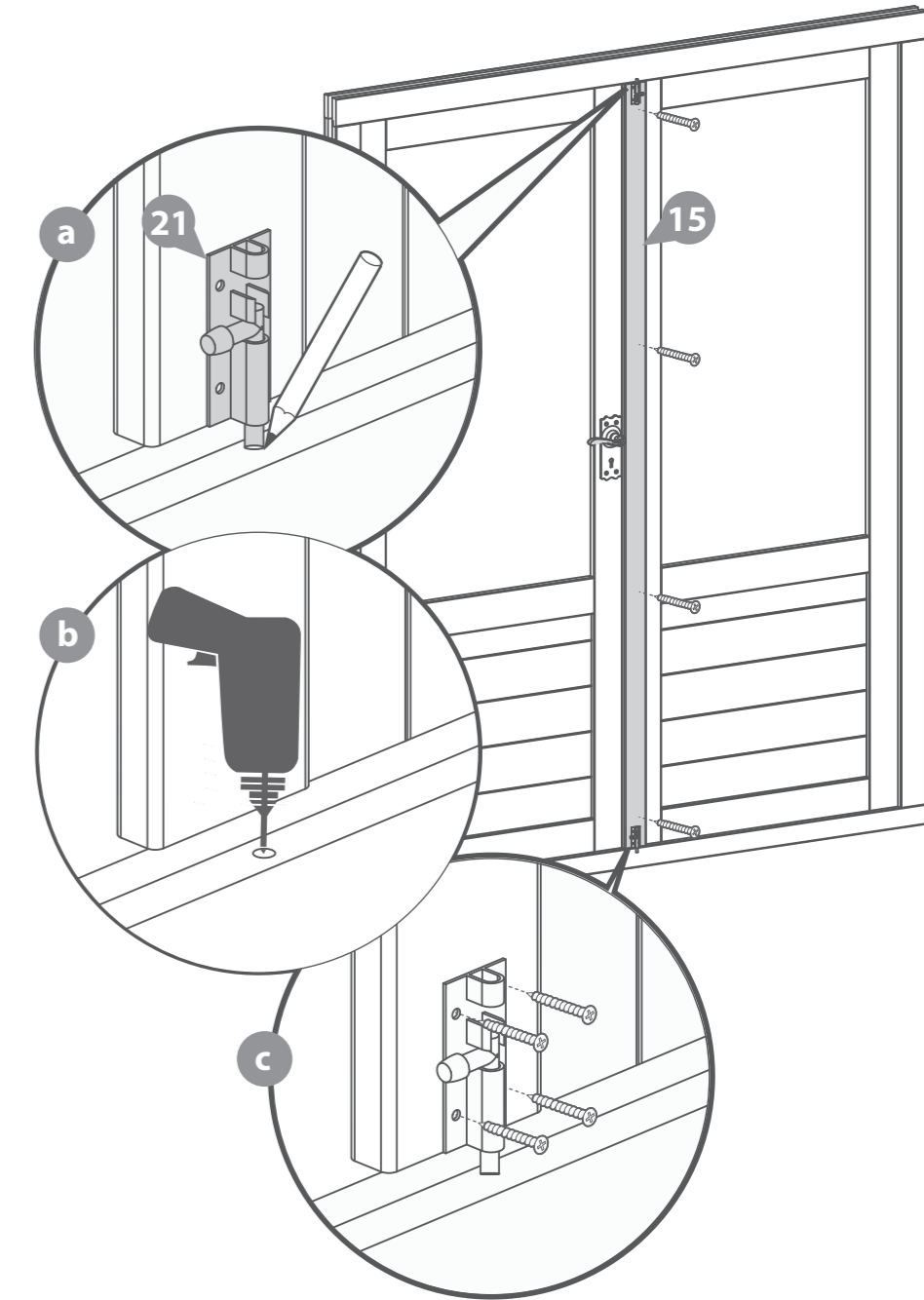

**Step 22**  
**Parts Needed - No. 41 QTY 35**

Place the first floor board (**No. 41**) inside the building flush to the log board on one side. Continue adding the floor boards (*internally*) making sure to interlock each individual board.

You have been issued with 35 floor boards, but in reality you may only need to use 34.

**\*Do NOT secure the boards until the last board has been measured and cut.**

Following the same method outlined previously measure the gap between the bottom of the tongue (**on the last board placed**) and the log board.

Using a straight edge mark out the measurement onto the last floor board (**No. 41**) and cut along the length removing the excess.

**\*\*Please note:** Mark the final board 2mm under the measurement; This will allow the timber to expand and contract correctly.

Once all the floor boards are in position secure each board into position using 8x40mm screws per board.

**\*\*\*Please Note:** Ensure to screw through each of the floor boards into the floor bearers.

**280x40mm Screws**



**IMPORTANT : Pre-drill before fixing screws.**

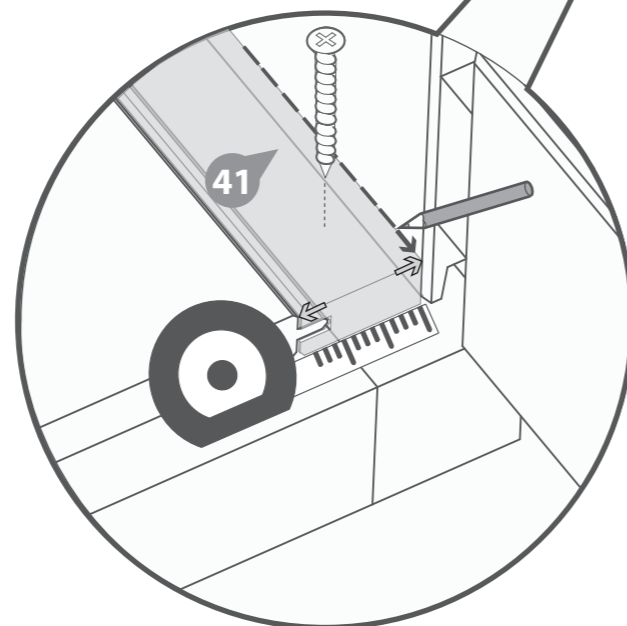
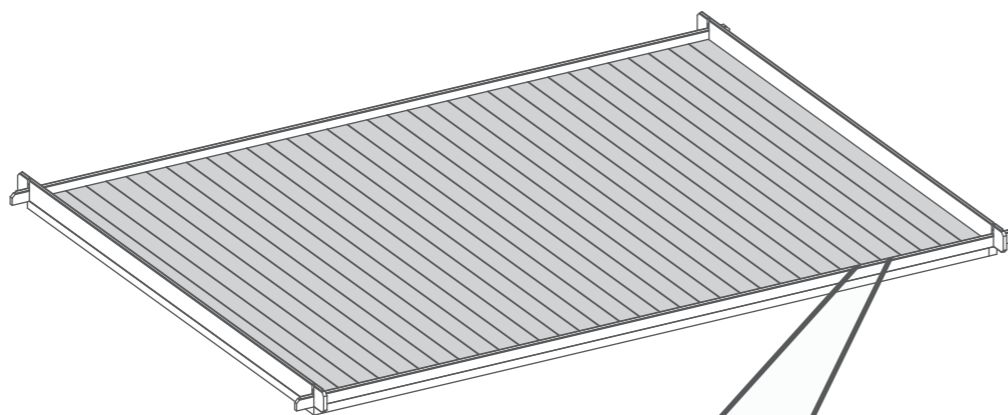
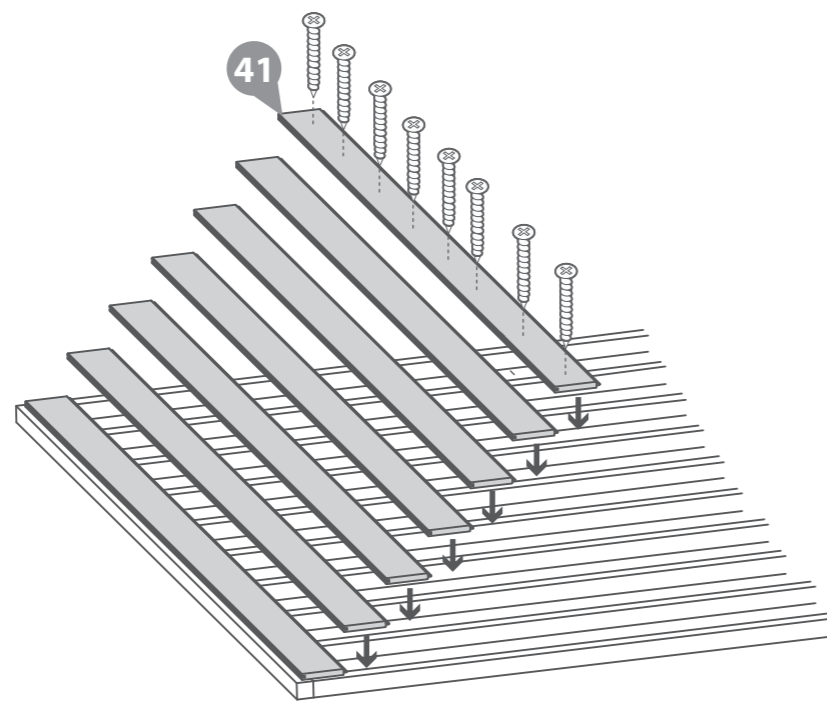

**Step 23**  
**Parts needed - No. 43 QTY 7**

Inside the building place the closure trim (**No. 43**) against the boarding and align with the roof as shown in the illustration.

**\*Measure and cut the closure trims to fit the internal space.**

Once in position fix each trim into place by pre drilling a pilot hole and using 6x30mm screws per trim, equally spacing them along the face of the board.

**42x30mm Screws**



**IMPORTANT : Pre-drill before fixing screws.**

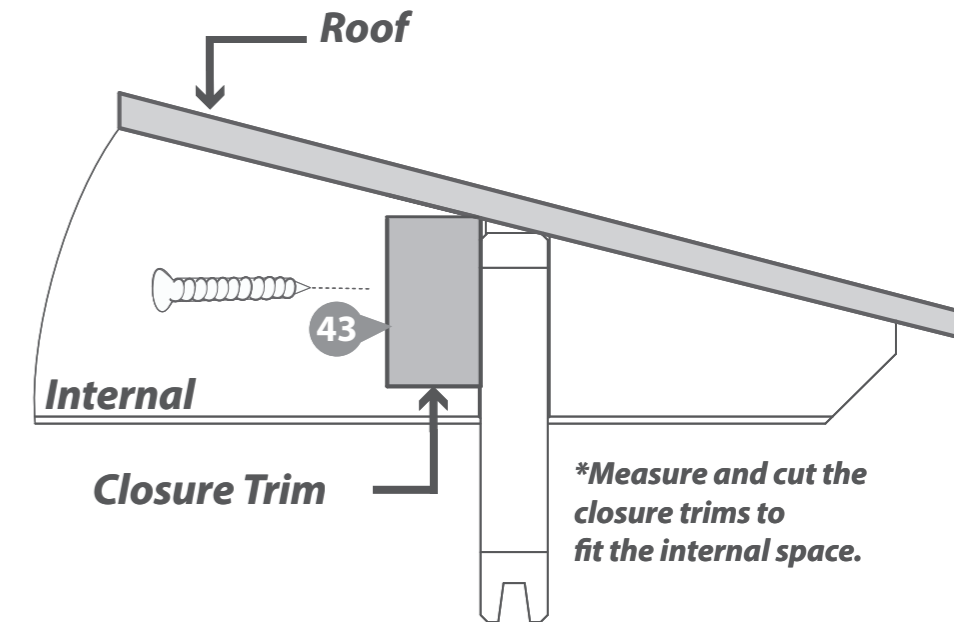

**Step 24**  
**Parts needed - No. 43 QTY 7**

Once the floor has been laid arrange the closure trim (**No. 43**) around the outside edge of floor (*internally*), measure and cut down accordingly to best match the internal space.

Secure each trim section into place using 6x30mm spaced equally along the board as shown in the illustration.

**\*Do NOT fix the closure trim to the floor boards.**

**42x30mm Screws**

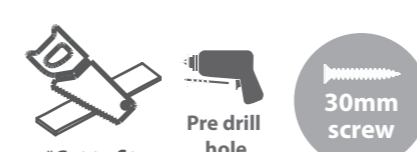

**IMPORTANT : Pre-drill before fixing screws.**

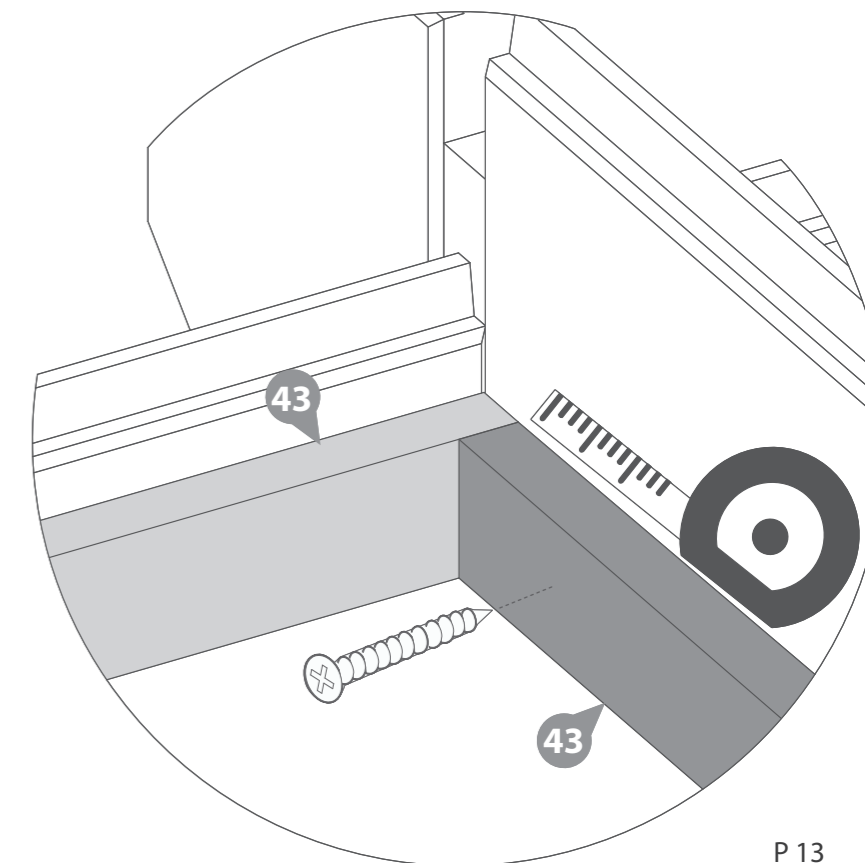

**Step 25**

**Parts needed - No. 45**

Cut the felt into four strips of: **4100mm (L) X 1000mm (W)** and lay onto the roof in the order shown in the illustration.

**\*Ensure there is approximately 50mm of overhanging felt each side.**

Once the felt is laid out fix to the roof using felt tacks at 100mm intervals.

**\*Felt size: 4100mm (L) X 1000mm (W)**

**210x Felt Tacks**

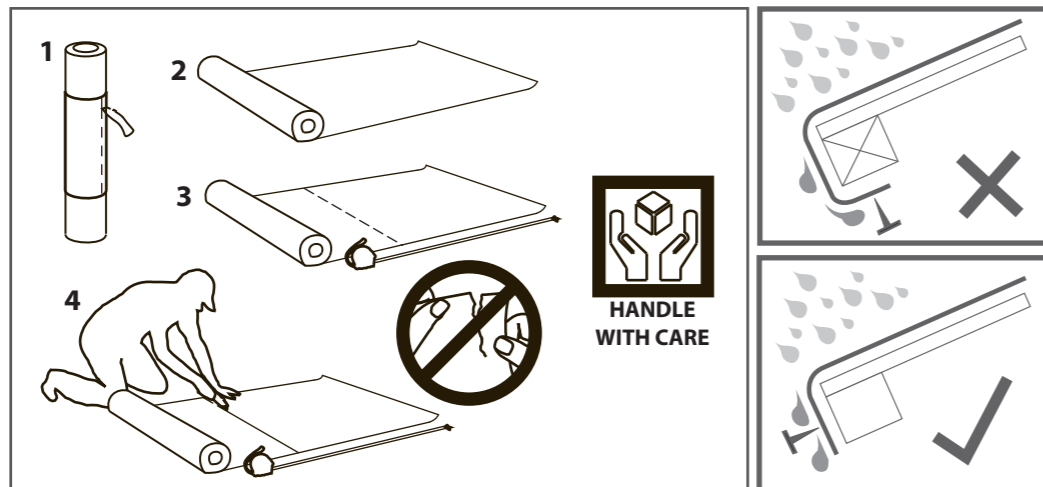
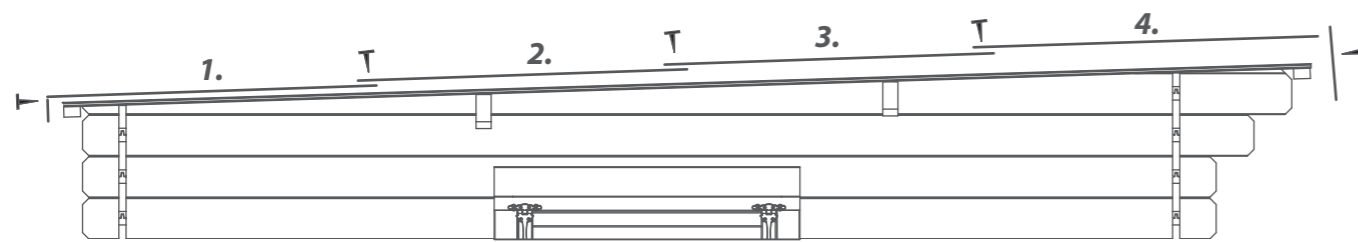
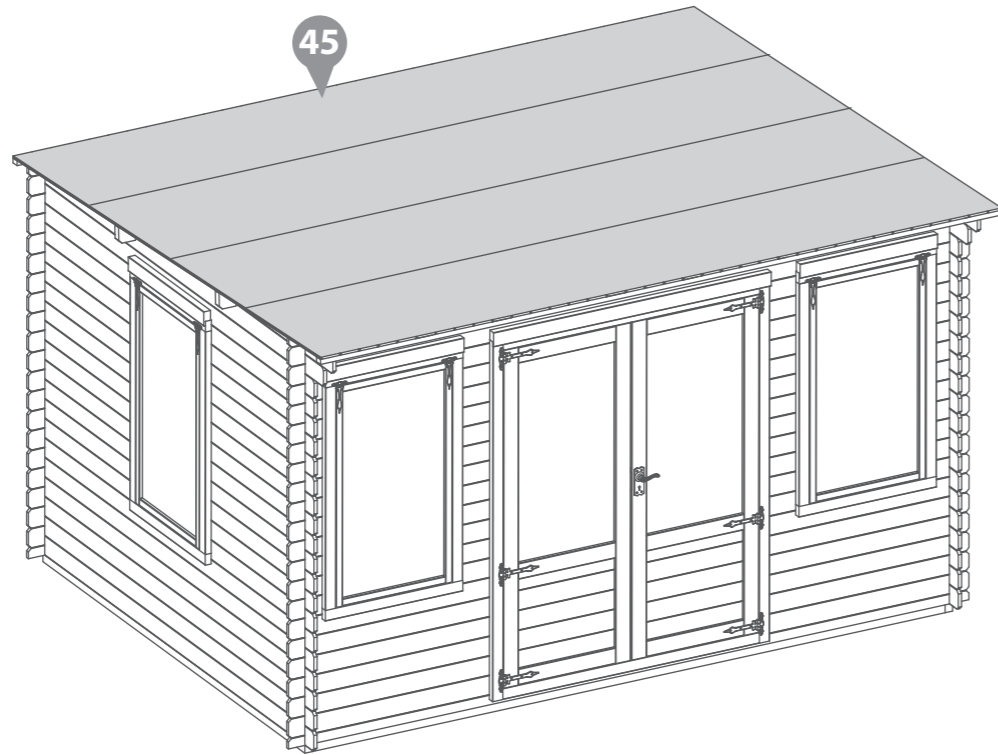

**Step 26**

**Parts Needed - No. 38 QTY 2**

**No. 39 QTY 2**

**IMPORTANT : Pre-drill before fixing screws.**

Attach the fascia's (**No. 38 & 39**) around the building (**ensuring to trap the felt in between the fascia's**) securing into place using 3x40mm screws per fascia.

**Ensure the fascia at the back of the log cabin sits level or lower than the felt to allow water to run off.**

**\*Once in place mark the excess fascia with a pencil and trim the fascias to follow the shape of building as shown in the illustration.**

**12x40mm Screws**

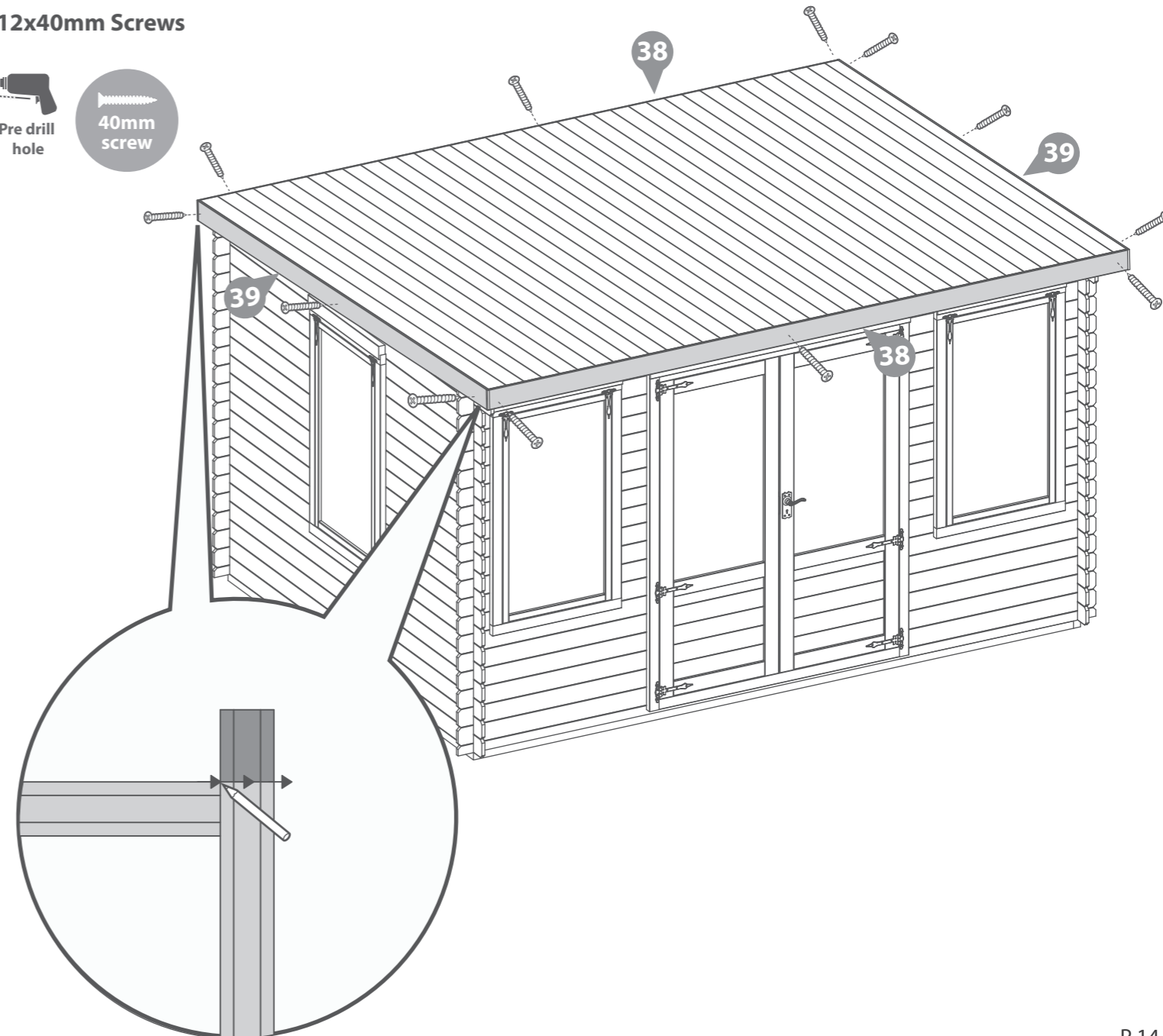
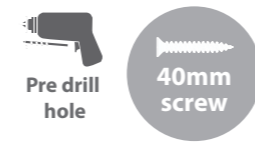

**Step 27**

**Parts needed - No. 44 QTY 8**

Arrange the storm braces (**No.44**) around the building (*internally*), Placing 2xStorm braces per side, fixing into place using 2x 60mm bolts per brace ,making sure the washer & nut are tightened from the outside of the building.

**\*Ensure the storm braces are secured at the highest point possible on each side.**

The storm braces will need to be altered during the buildings life as the moisture content within the log boards changes. The boards will expand during periods of high moisture (Winter) and shrink during periods of low moisture (Summer.)

**\*\*Storm braces will help your building expand and contract properly.**

**\*\*\*Important: Ensure each bolt is tightened using a washer so as not to damage the log boards.**

**16x60mm Bolt Sets**

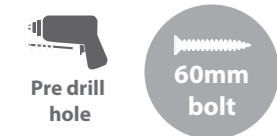

**IMPORTANT : Pre-drill before fixing screws.**

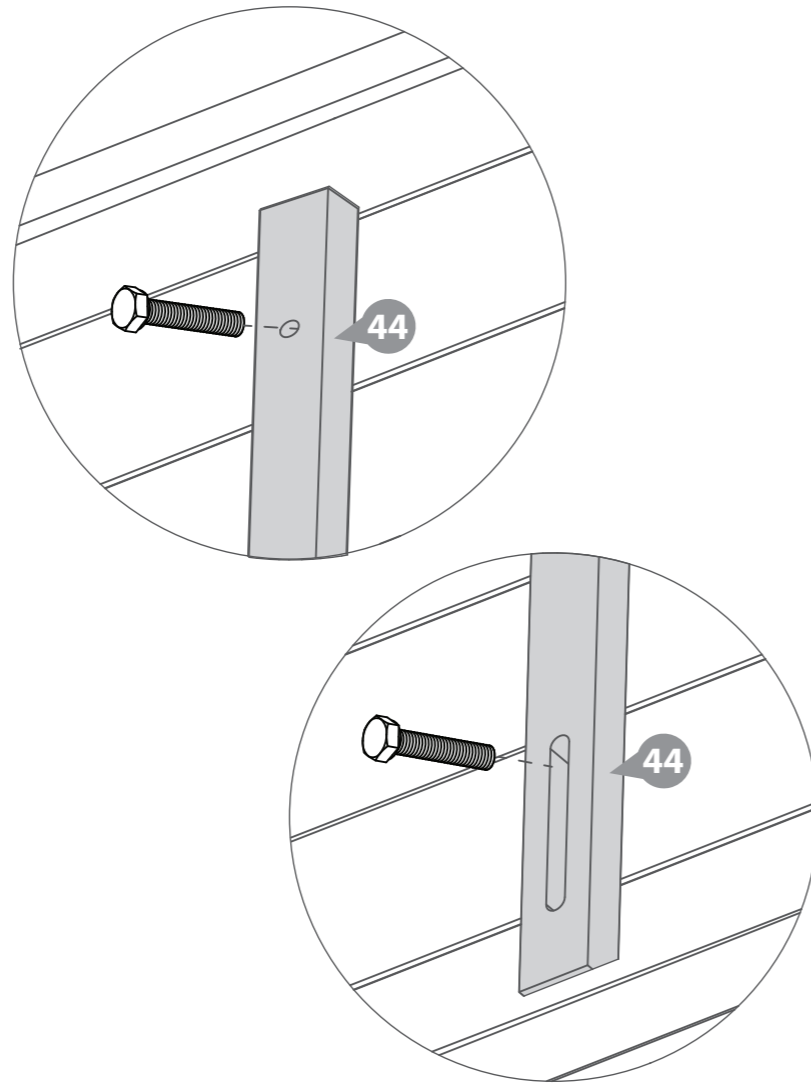

**Step 28**

**Parts Needed: No. 6 QTY 3  
No. 16 QTY 1**

Attach the Rain Guards (**No. 6**) to the Window frame, fixing in place onto the framing above the window using 3x70mm screws per guard.

Attach the Rain Guard (**No. 16**) to the Door frame, fixing in place onto the framing above the Door using 3x70mm screws.

**12x70mm Screws.**

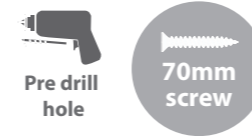

**IMPORTANT : Pre-drill before fixing screws.**

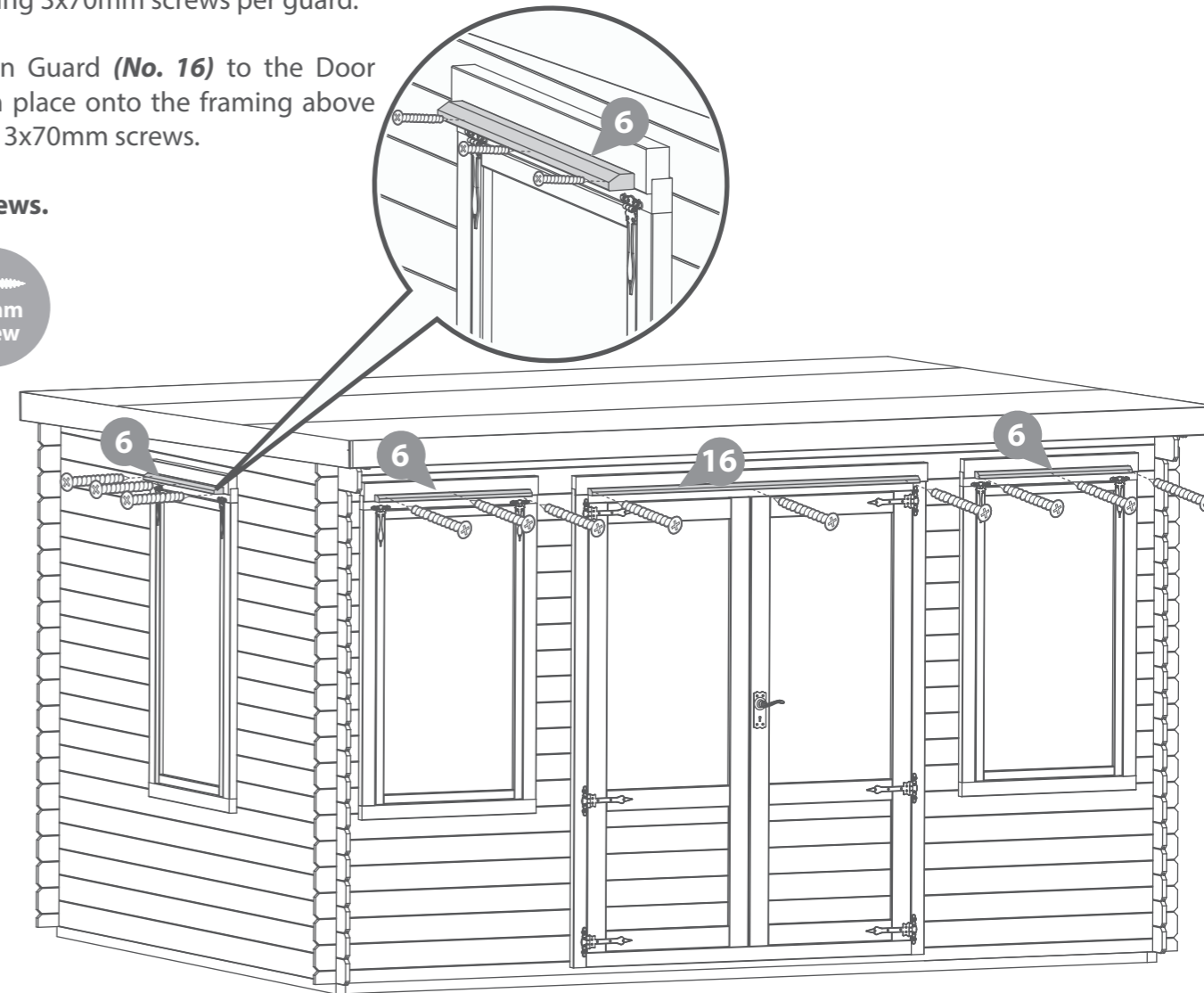

**It is ESSENTIAL that you apply wood treatment immediately after the building has been assembled.**



**AFTER TREATMENT:** score around protective cover on glazing and carefully peel covering back

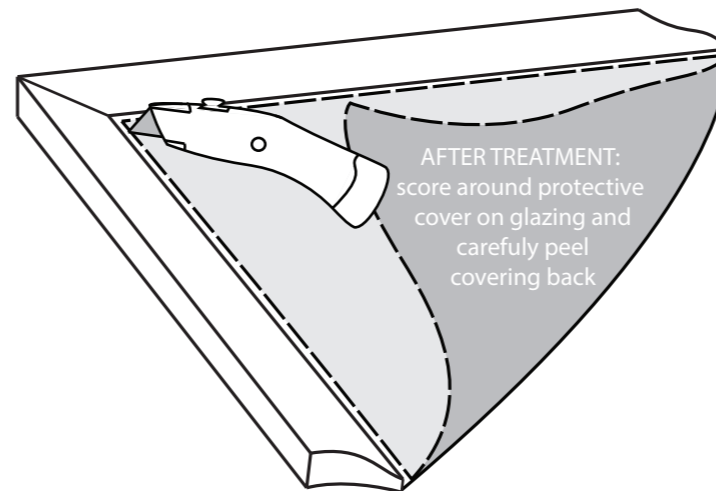

**It is ESSENTIAL to seal around all window framing with silicone sealant (not included) to minimise water ingress.**

