

Coffee Table

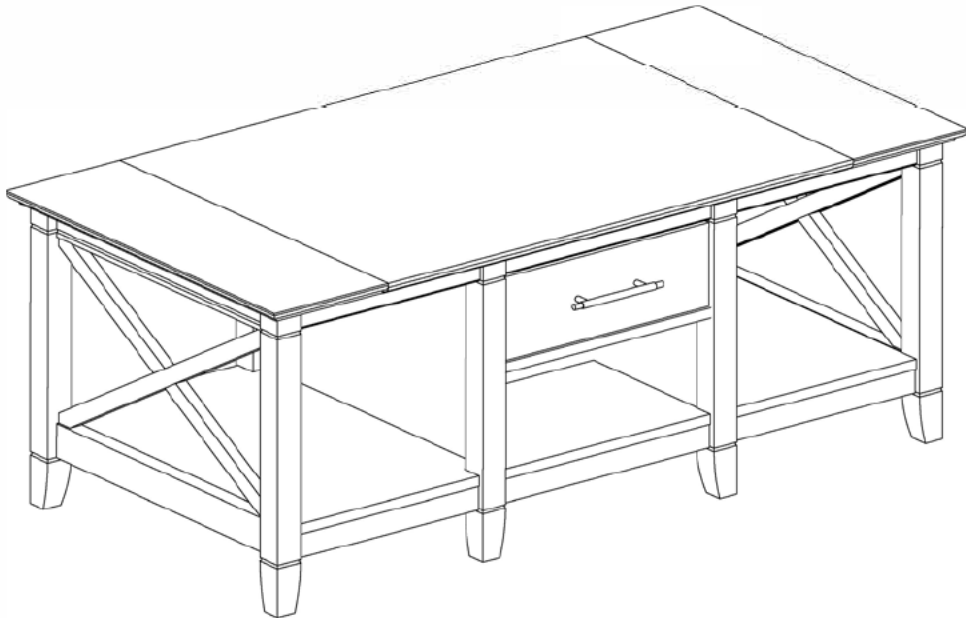

Get Ready to Assemble

For best results, keep these tips in mind:

- ① We know you want to finish this assembly as quickly as possible, but trust us: you'll have a better experience if you take it one step at a time.
- ② Give yourself some room to work near where you want the fully assembled product.
- ③ If your floor isn't carpeted, assemble this product on the empty carton to avoid scratching.
- ④ Do you have a friend who owes you a favor? Some steps may go a little easier with a second set of hands.

DOs

- ✔ Use a #2 Phillips head screwdriver (or other handheld tools as indicated)
- ✔ Wear safety glasses at all times during assembly
- ✔ Carefully follow the instructions in this guide and complete all steps in order
- ✔ Give us a call if you're having trouble with a particularly tricky step

DON'Ts

- ✘ We know power tools are quick and easy, but you shouldn't use them when assembling this product (unless otherwise specified)
- ✘ Never move your furniture with items inside or resting on the surface
- ✘ Do not attempt to use this product before all steps have been completed

IMPORTANT SAFETY INFORMATION



PLEASE READ WARNINGS

Improper use can cause safety hazards, or damage to your furniture and household items.

Warning	Do	Don't	Why it's important
Serious injury may occur.	<ul style="list-style-type: none">Assemble following all instructions using all indicated parts and hardware provided.	<ul style="list-style-type: none">Do not move unit when loaded.Do not load with a television or other heavy equipment.Do not exceed the maximum load limits stated in the instructions.	Improper assembly, use or loading can lead to product instability, tip-over or collapse.

Advertencia	Hacer	No	Por qué es importante
Se pueden producir lesiones graves.	<ul style="list-style-type: none">Ensamble siguiendo todas las instrucciones utilizando todas las piezas y ferretería indicados provistos.	<ul style="list-style-type: none">No mueva la unidad cuando esté cargada.No cargue con un televisor u otro equipo pesado.No exceda los límites máximos de carga establecidos en las instrucciones.	El ensamblaje, uso o carga inadecuados pueden provocar inestabilidad del producto, vuelco o colapso.





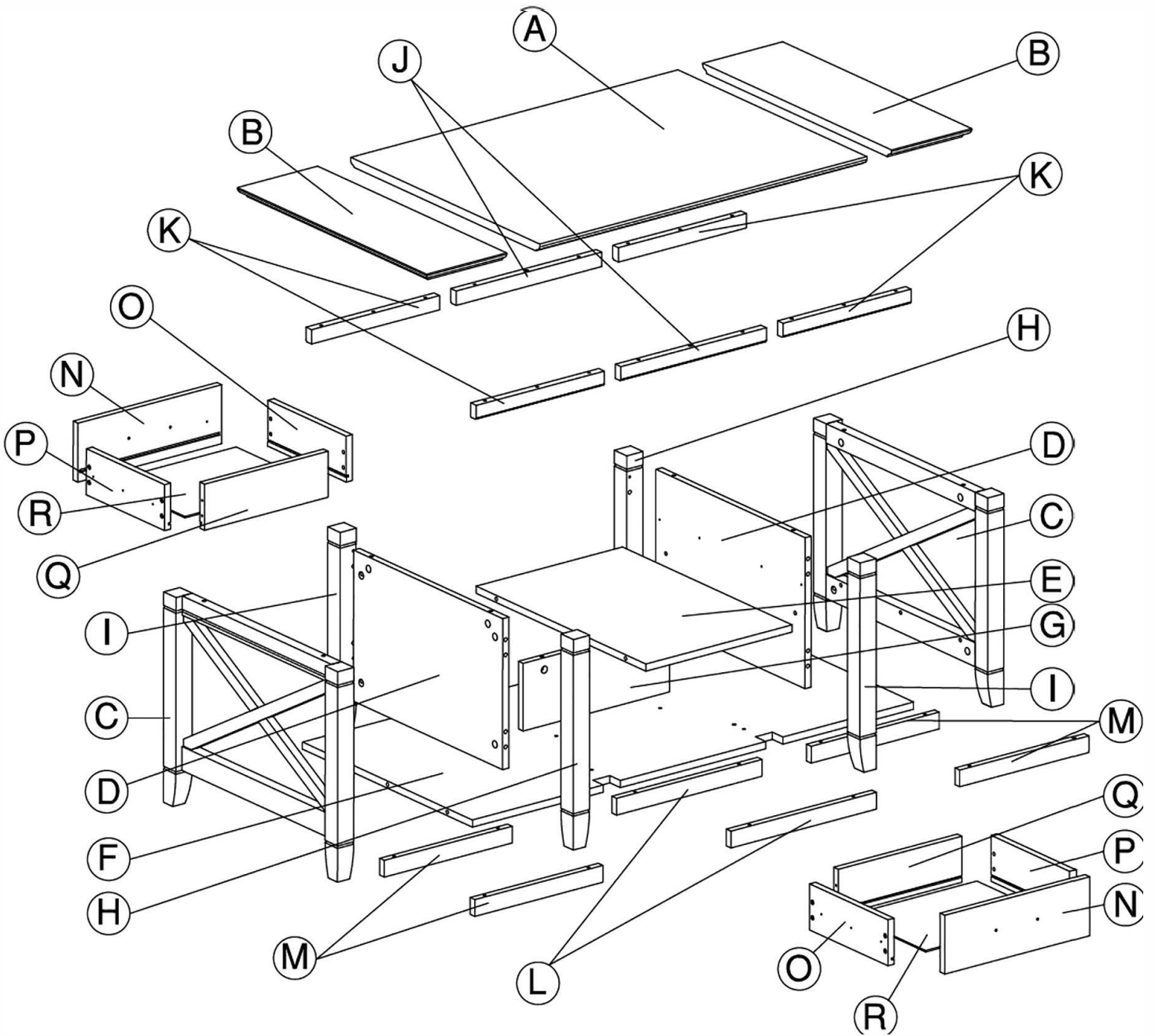
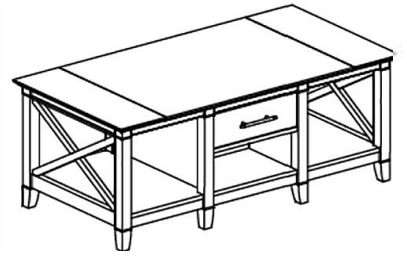

Avertissement	Faire	Ne le fais pas	Pourquoi c'est important
Des blessures graves peuvent survenir.	<ul style="list-style-type: none">Assemblez en suivant toutes les instructions en utilisant toutes les pièces et le matériel indiqués fournis.	<ul style="list-style-type: none">Ne déplacez pas l'unité lorsqu'elle est chargée.Ne chargez pas avec un téléviseur ou un autre équipement lourd.Ne dépassez pas les limites de charge maximale indiquées dans les instructions.	Un assemblage, une utilisation ou un chargement incorrects peuvent entraîner une instabilité du produit, un renversement ou un effondrement.

Get to know your Boards

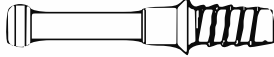

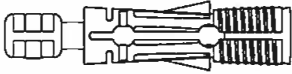
Get to know your Fasteners

Fasteners are shown actual size.

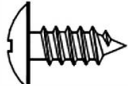
H181468	 KD Cam	[28]	H180604	 KD Bolt	[8]
H38169	 Wood Dowel 8 x 30mm	[14]	H171556	 Quick Connect	[20]
H158933	 #8 x 3/4"	[4]	H23198	 #10 x 1-1/2"	[14]
H23370	 #10 x 1-1/4"	[28]	H101725	 #6 x 1/2"	[32]
H35251	 #10 x 1/2"	[20]			

Get to know your Hardware

Hardware not to scale.

Q184100

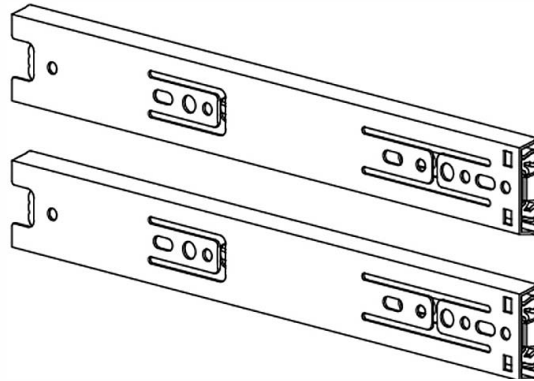

[2]

10" Slide

H100444



[4]

Drawer Bracket

H39922

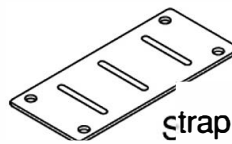

[4]

strap

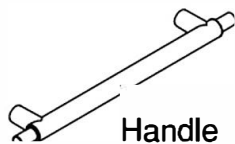

[2]

Handle



[14]

Cover Cap

STEP 1

Prepare Drawer Fronts

H100444



Drawer Bracket

[4]

H158933



#8 x 3/4"

[4]

H35251



#10 x 1/2"

[4]

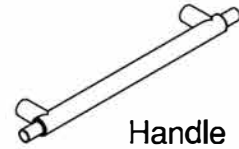

Handle

[2]

2 X

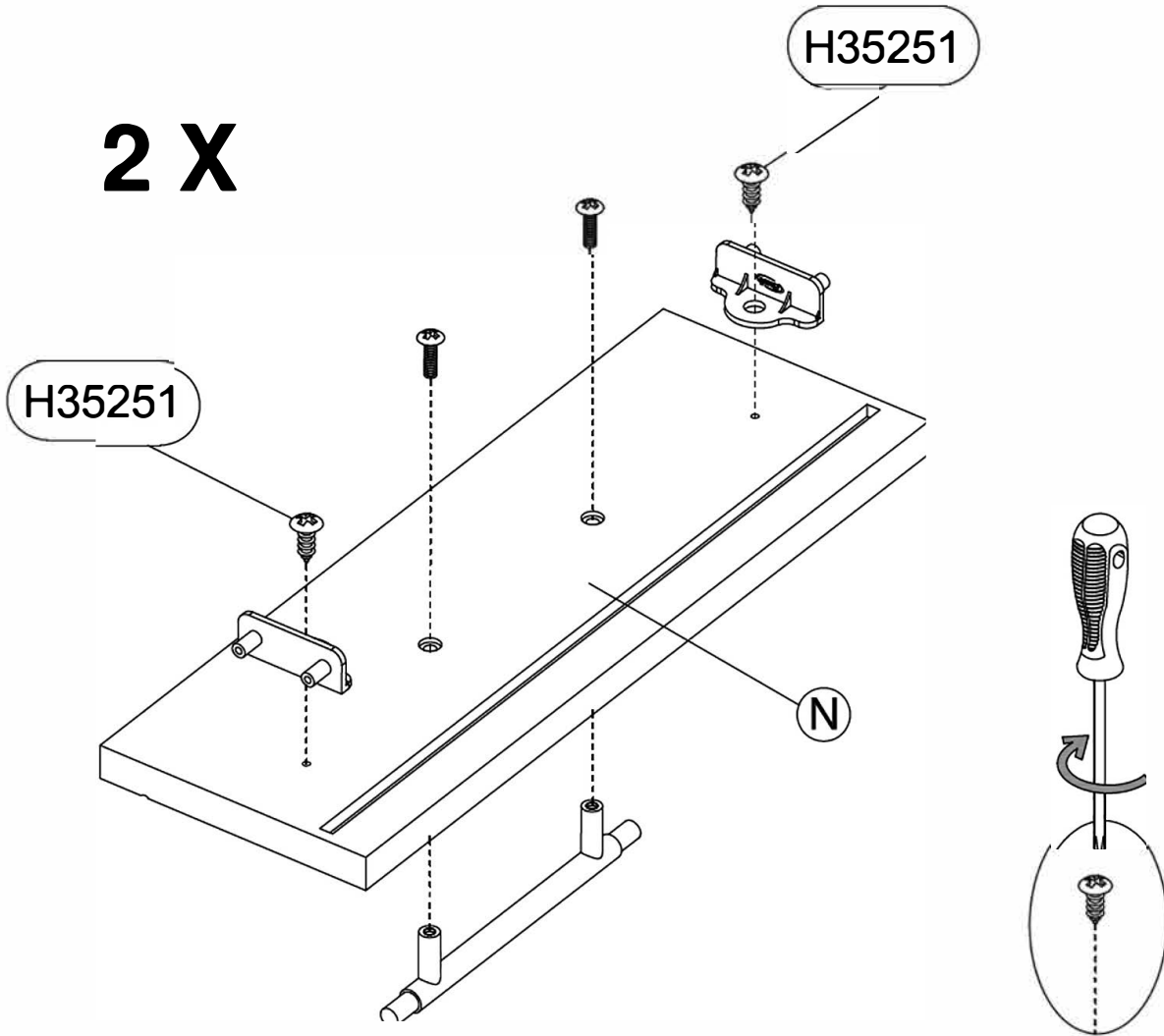

STEP 2

Build Drawers

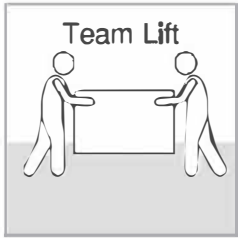

H101725  [8]
#6 x 1/2"

H23198  [8]
#10 x 1-1/2"

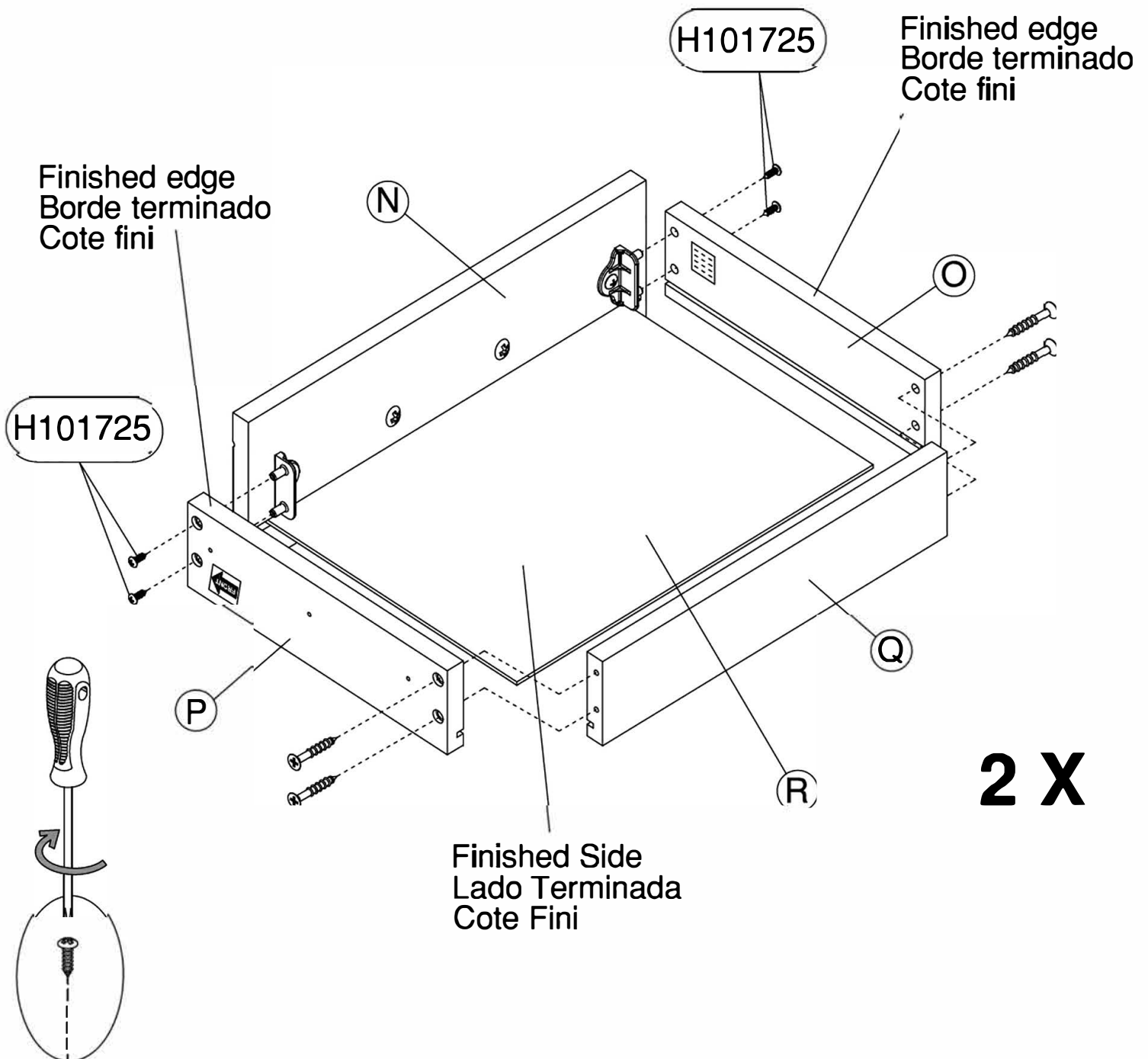

STEP 3

Separate Slides

**Slides Must Be Separated Before Assembly.
After Separated, Set Aside Until Needed for Assembly.**

Las diapositivas deben separarse antes del montaje.
Después de la separación, déjelo a un lado hasta que sea necesario.

Les glissières doivent être séparées avant l'assemblage.
Après la séparation, mettez de côté jusqu'au moment de l'assemblage.

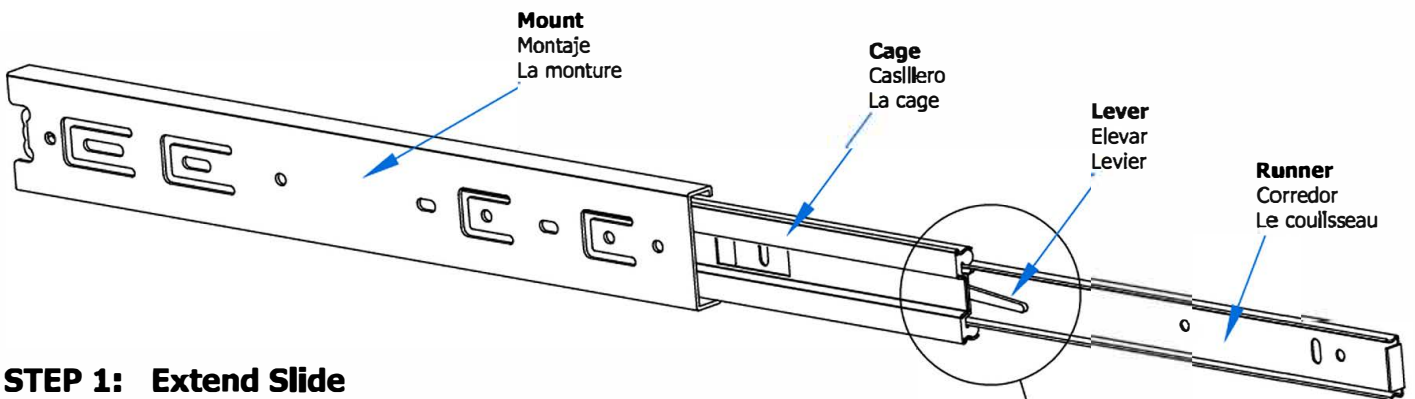

STEP 1: Extend Slide
Extender la diapositiva
Extendre la diapositive

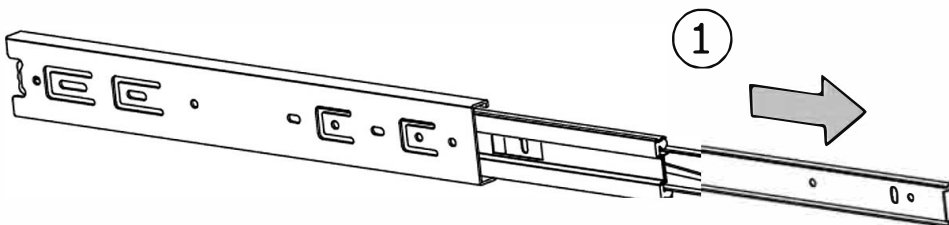

STEP 2: Push Lever UP
Empujar hacia arriba
Lever le levier

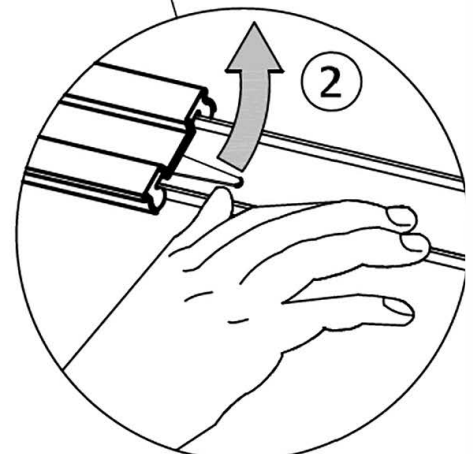

STEP 3: Remove Runner
Quitar el corredor
Enlever le coureur

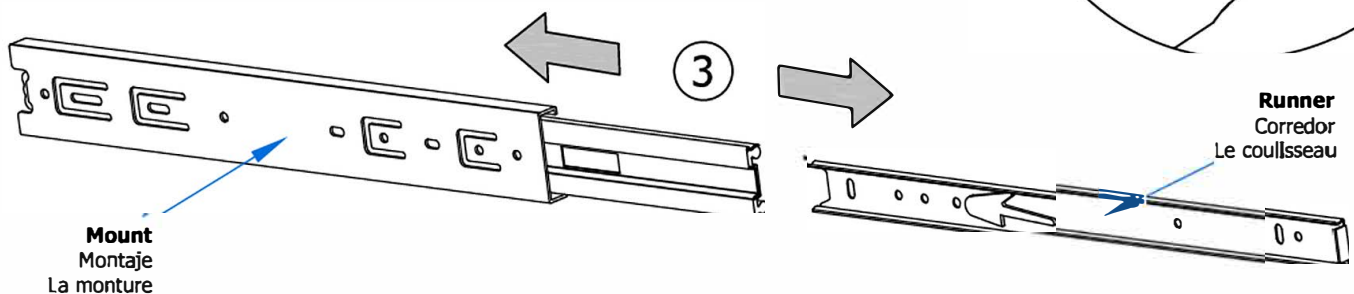

STEP 4

Install Slide Runners

Q184100

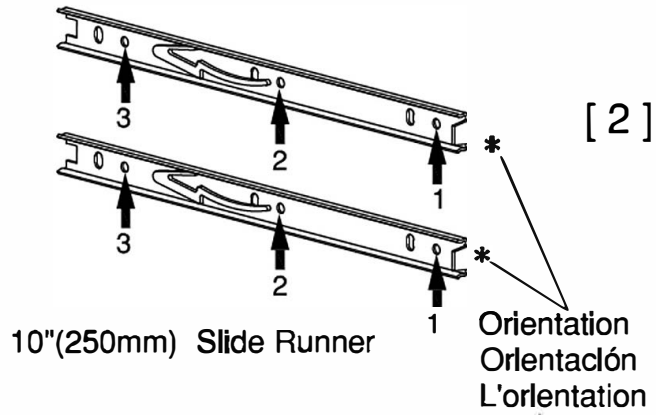

H101725 [12]
#6 x 1/2"

Orientation
Orientación
L'orientation

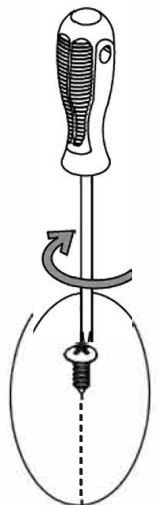
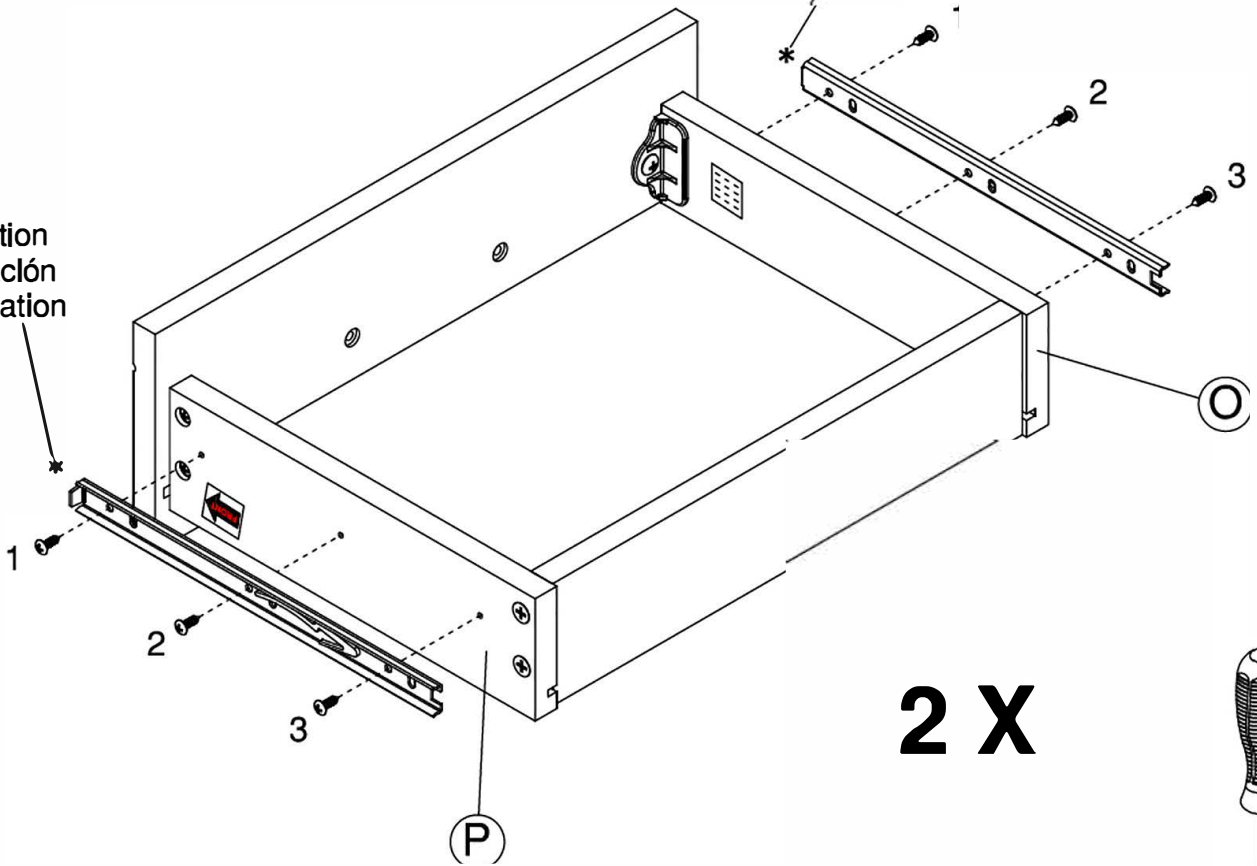

STEP 5

Prepare Panels

H180604



[8]

KD Bolt

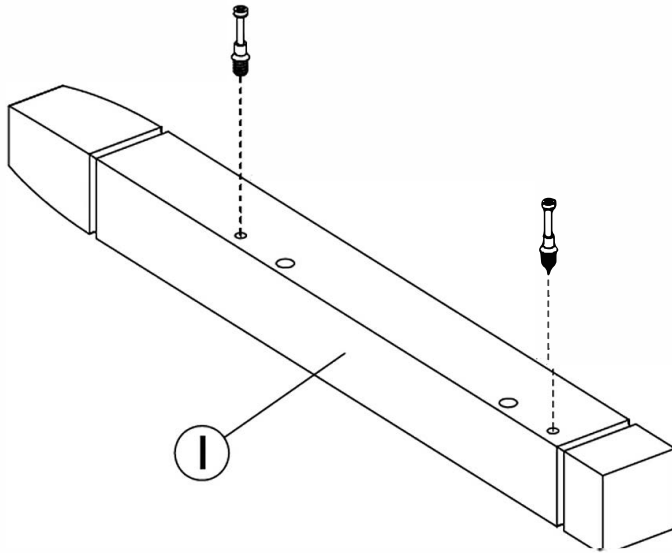

2 X

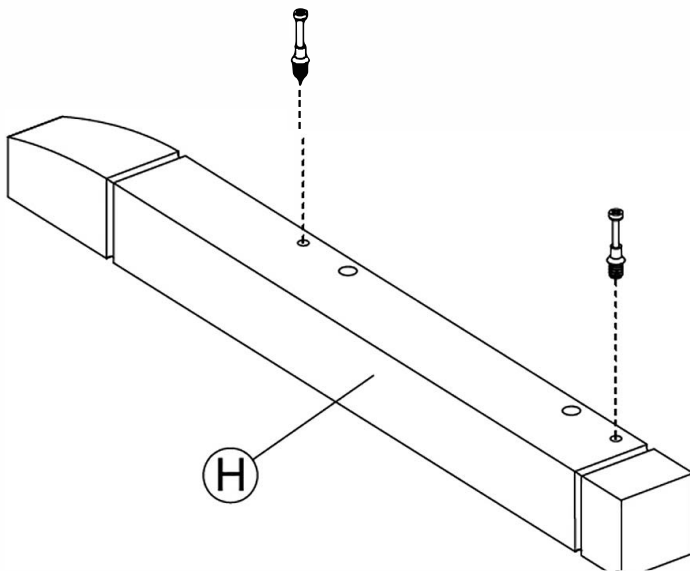

2 X

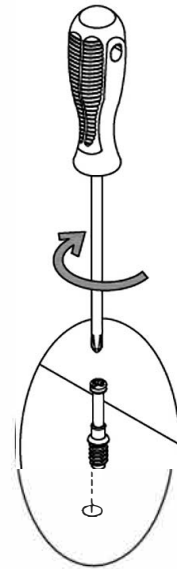

STEP 6

Prepare Panels

H38169



[12]

Wood Dowel
8 x 30mm

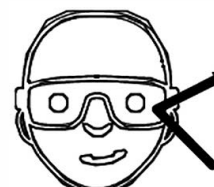
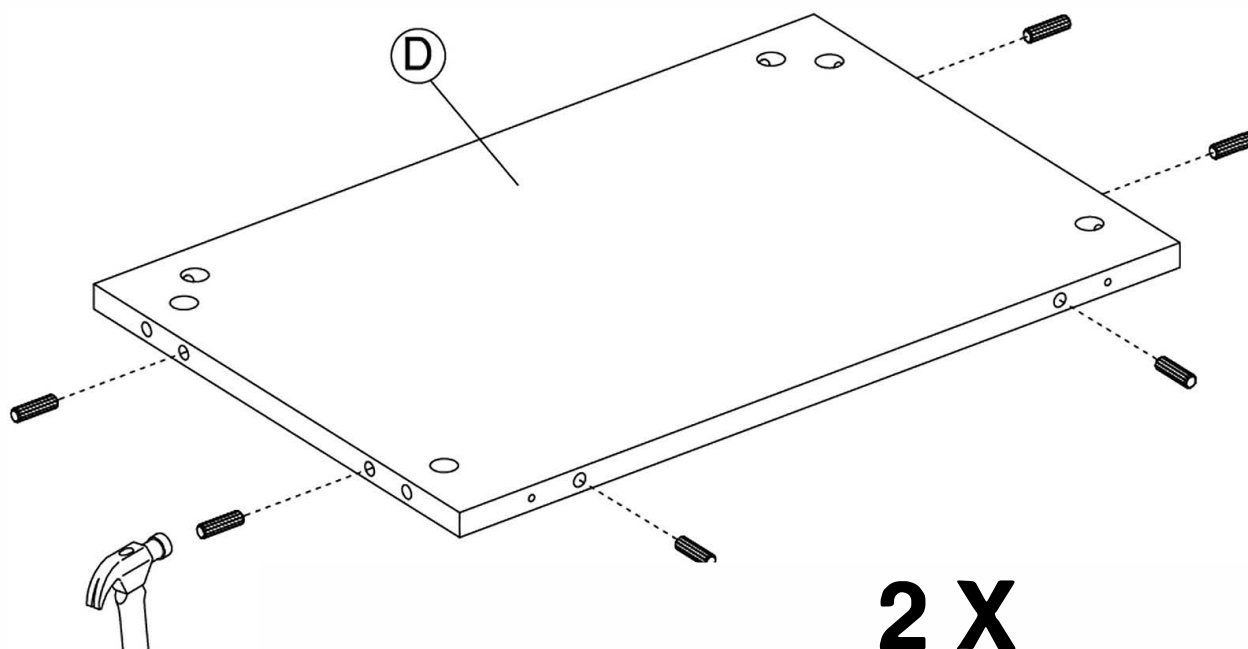

Safety glasses
Gafas de seguridad
Lunettes de protection

STEP 7

Assemble Panels

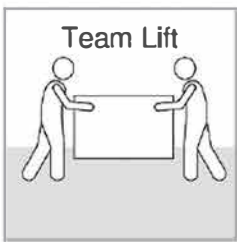
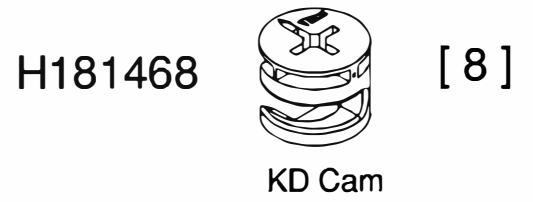
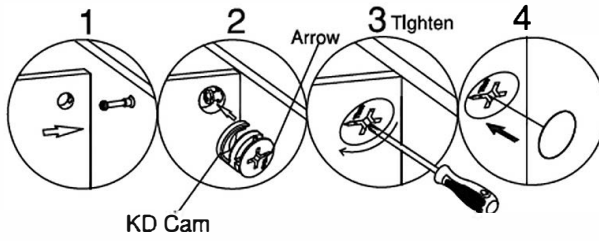

2 X

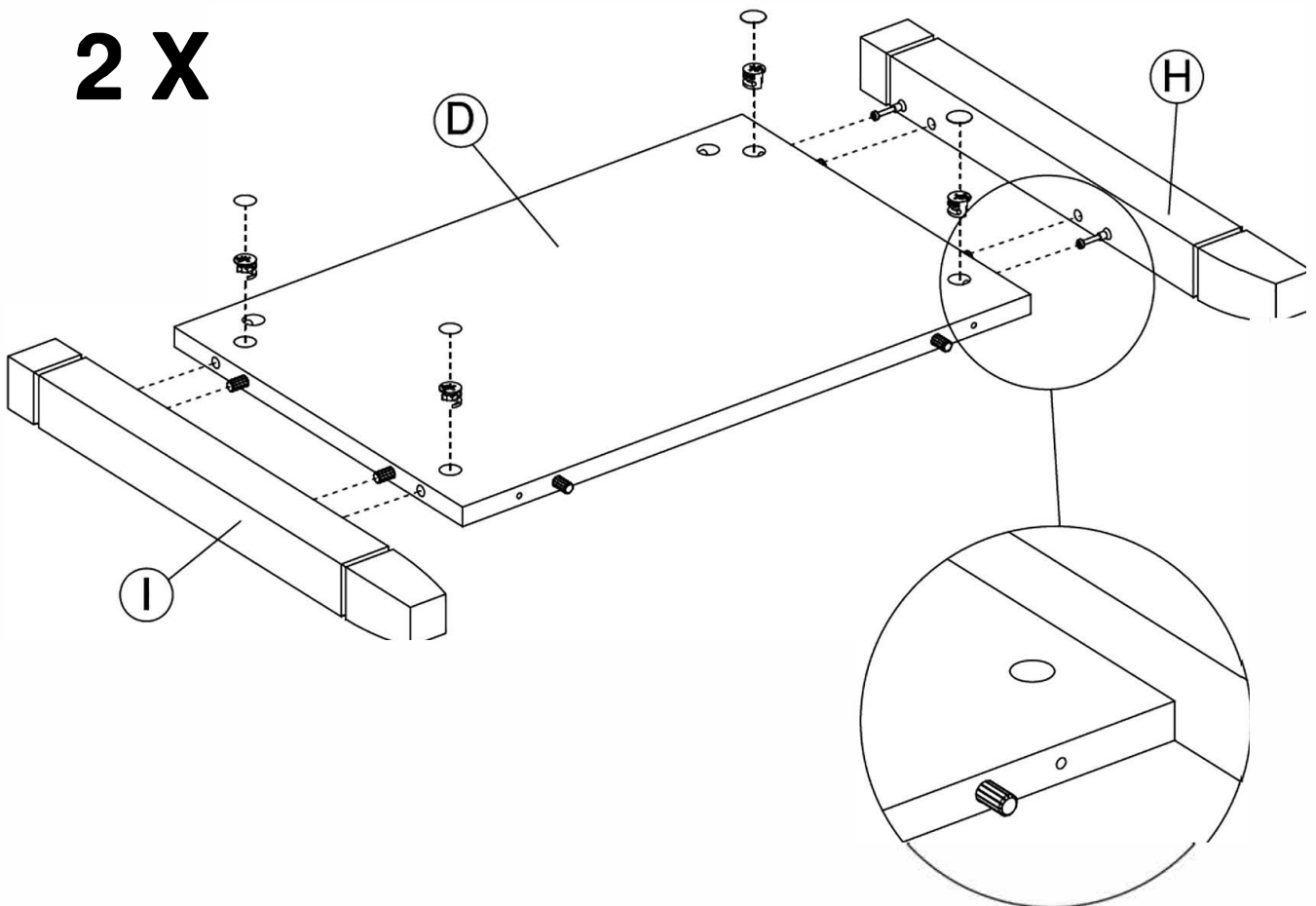

STEP 8

Install Mounts

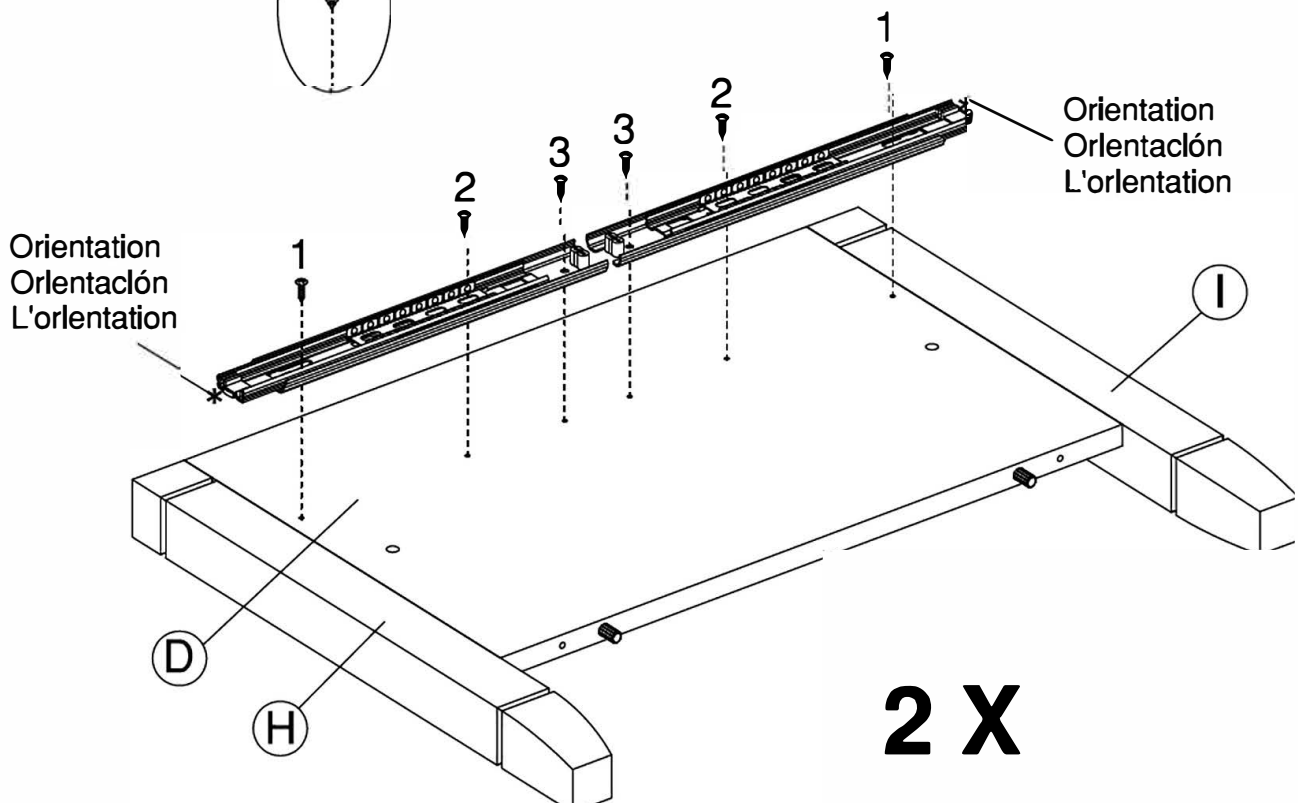
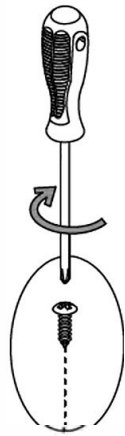
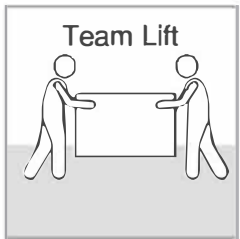
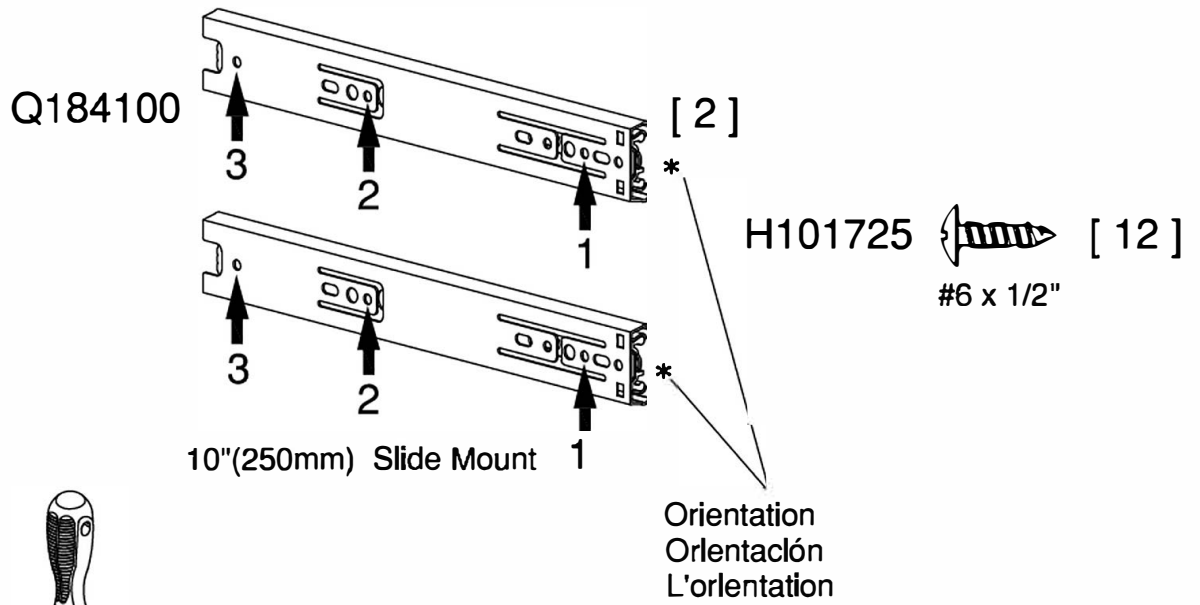

STEP 9

Insert Fasteners

H171556

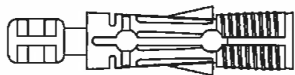

[4]

Quick Connect

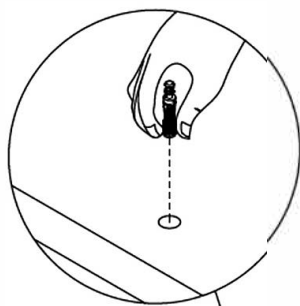
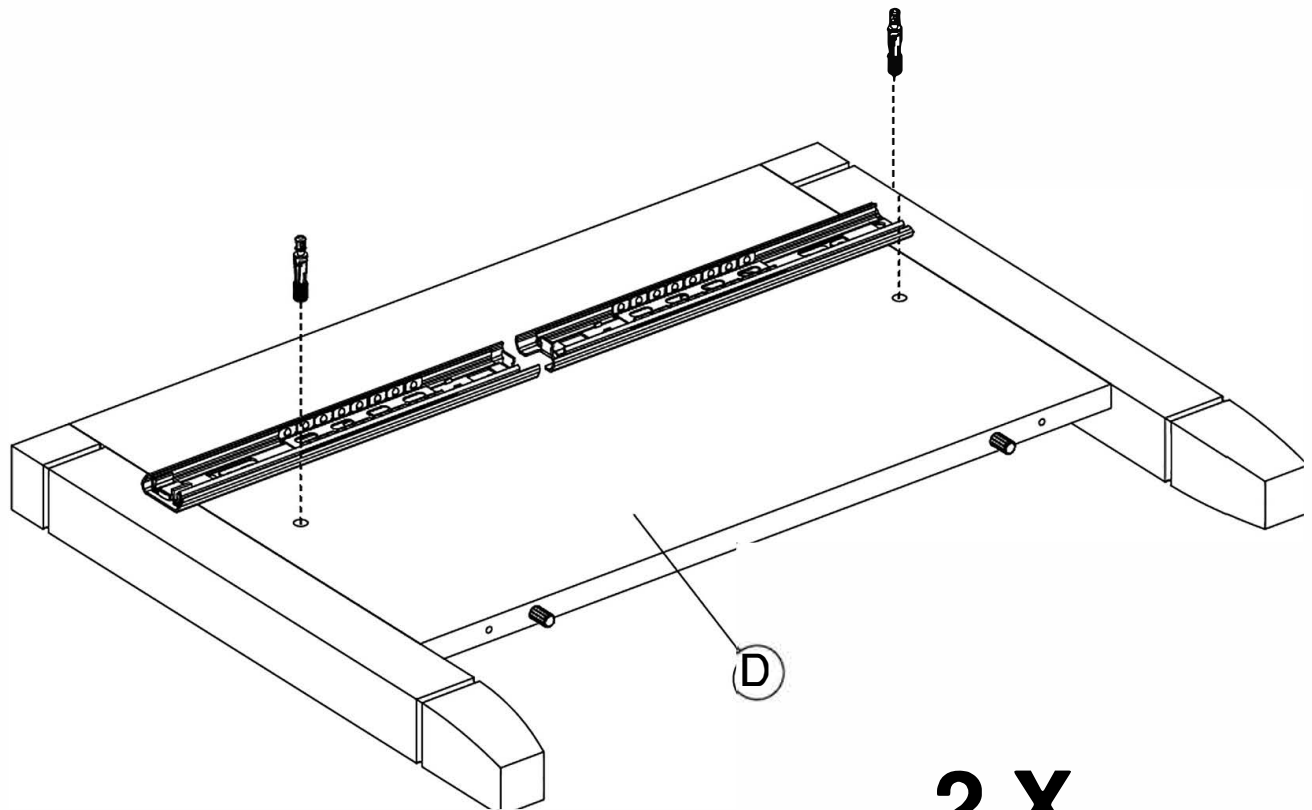

MAY HAVE TO SQUEEZE PLASTIC TO INSERT INTO HOLE.
PUEDE TENER QUE APRETAR PLÁSTICO PARA INSERTAR EN EL AGUJERO.
PEUT AVOIR À PRESSER EN PLASTIQUE À INSÉRER DANS LE TROU.

STEP 10

Prepare Panel

H171556

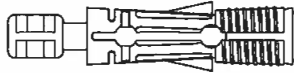

[2]

Quick Connect

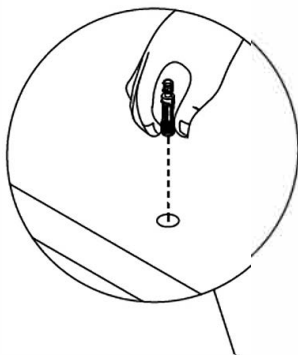
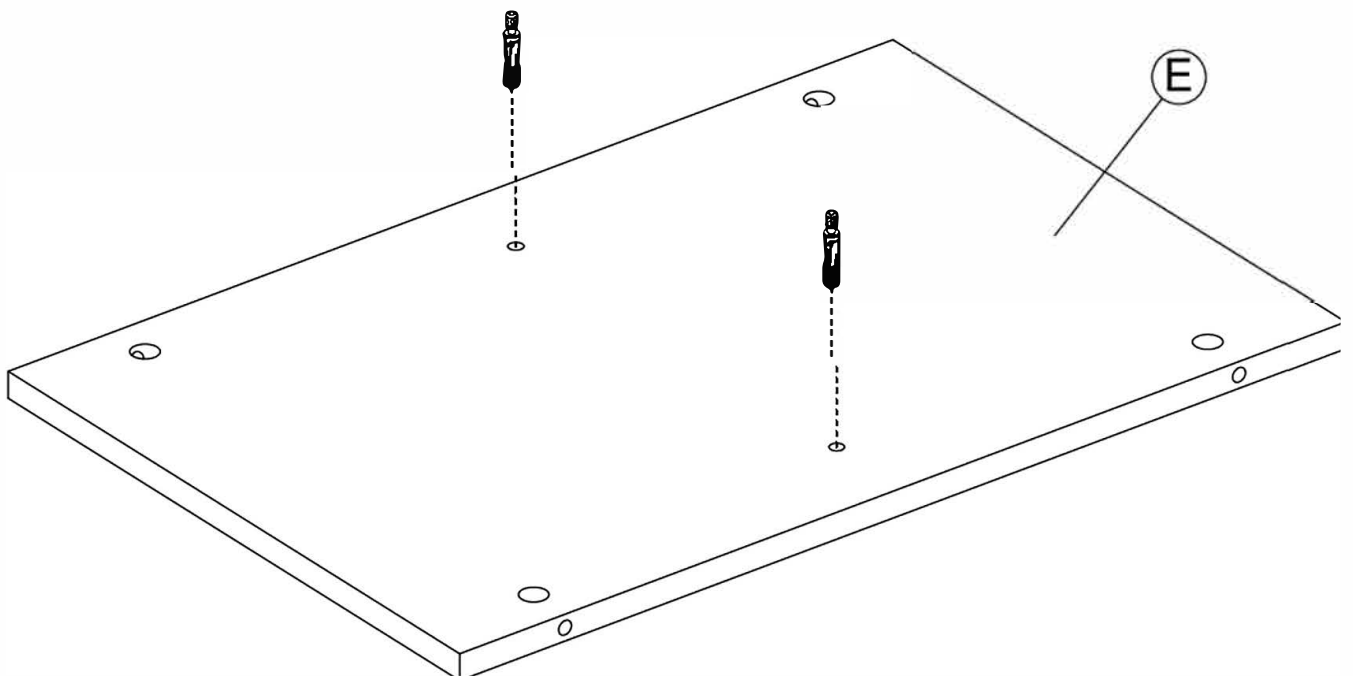

MAY HAVE TO SQUEEZE PLASTIC TO INSERT INTO HOLE.
PUEDE TENER QUE APRETAR PLÁSTICO PARA INSERTAR EN EL AGUJERO.
PEUT AVOIR À PRESSER EN PLASTIQUE À INSÉRER DANS LE TROU.

STEP 11

Assemble Panels

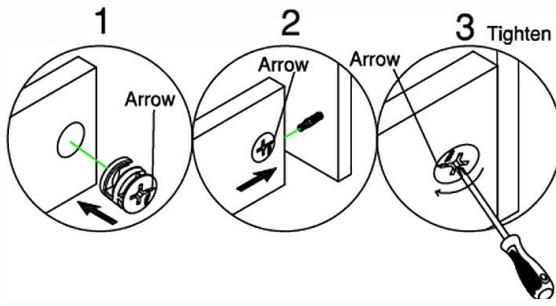

H181468



[2]

KD Cam

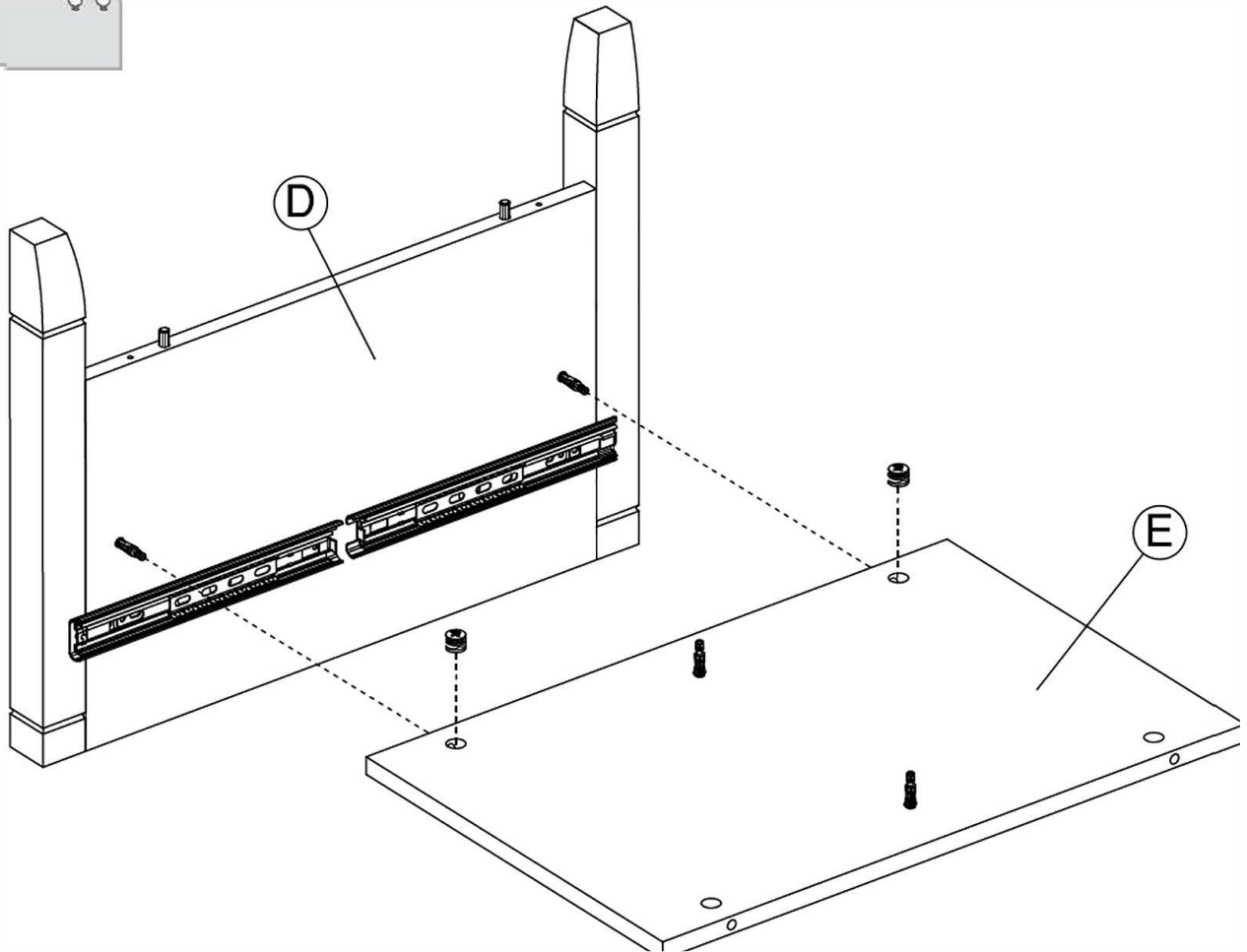
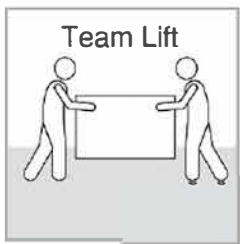

STEP 12

Assemble Panel

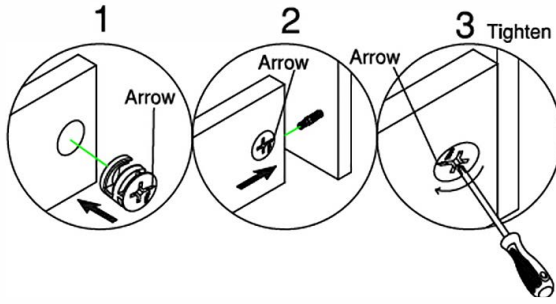

H181468



[2]

KD Cam

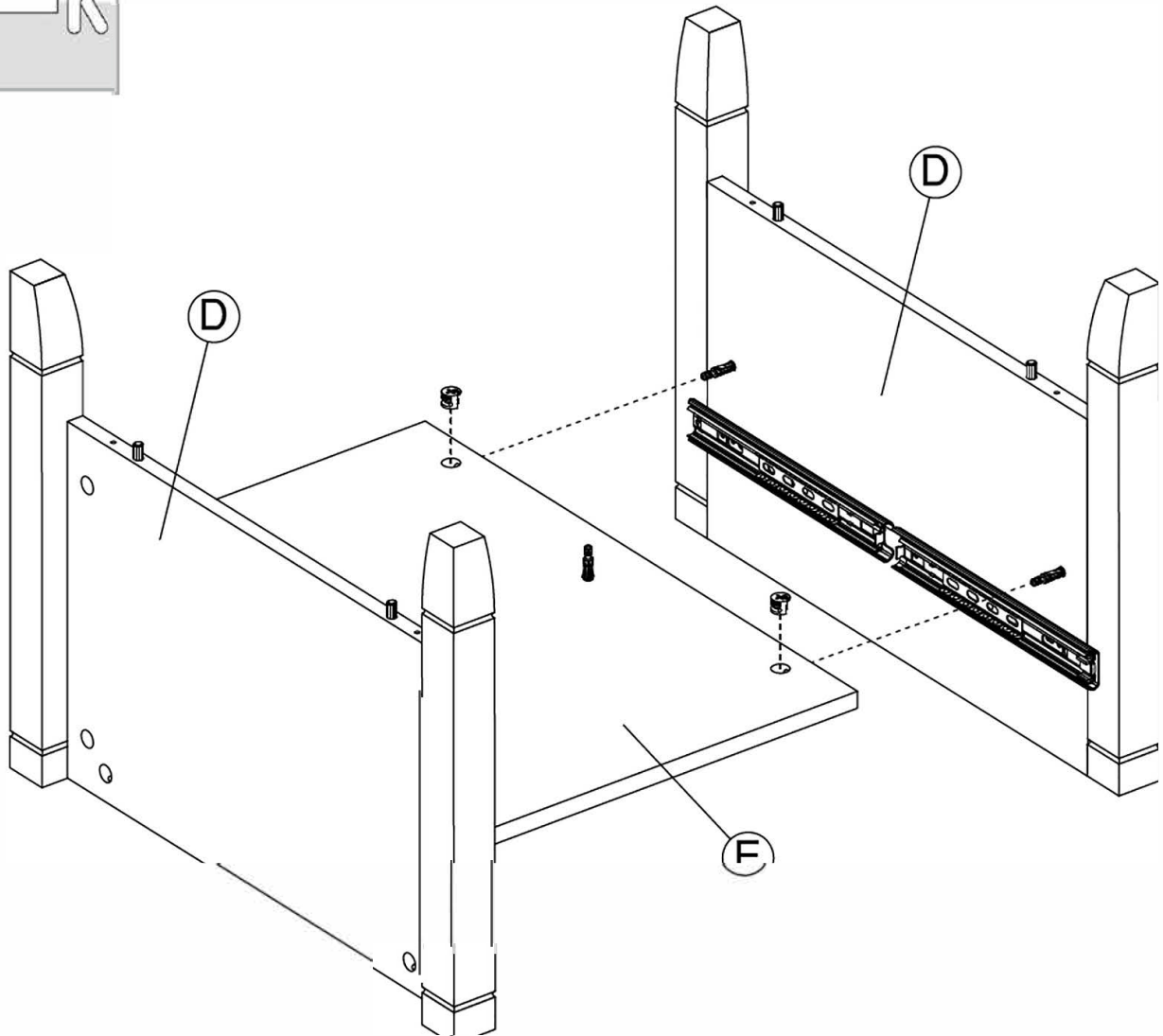
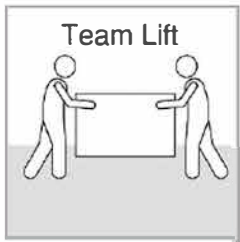

STEP 13

Assemble Panel

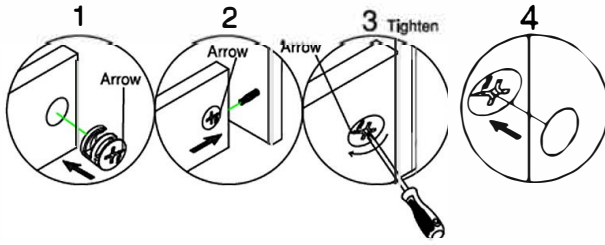

H181468

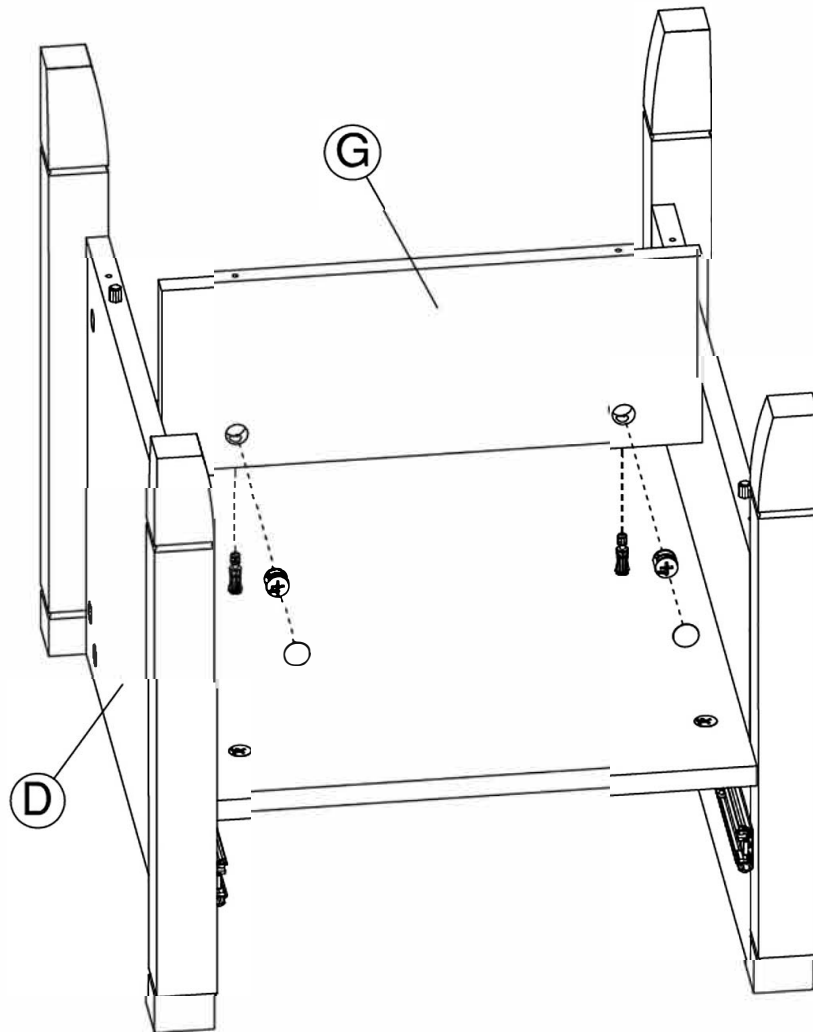
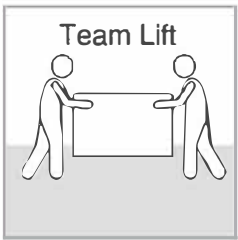
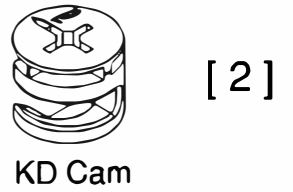

STEP 14

Assemble Panels

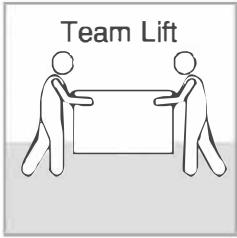

H23198



[6]

#10 x 1-1/2"

Raw Side
Lado Crudo
Cote Brut

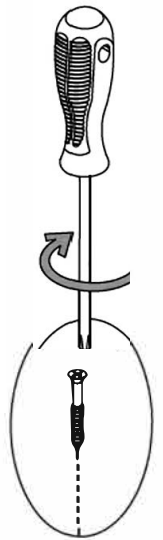
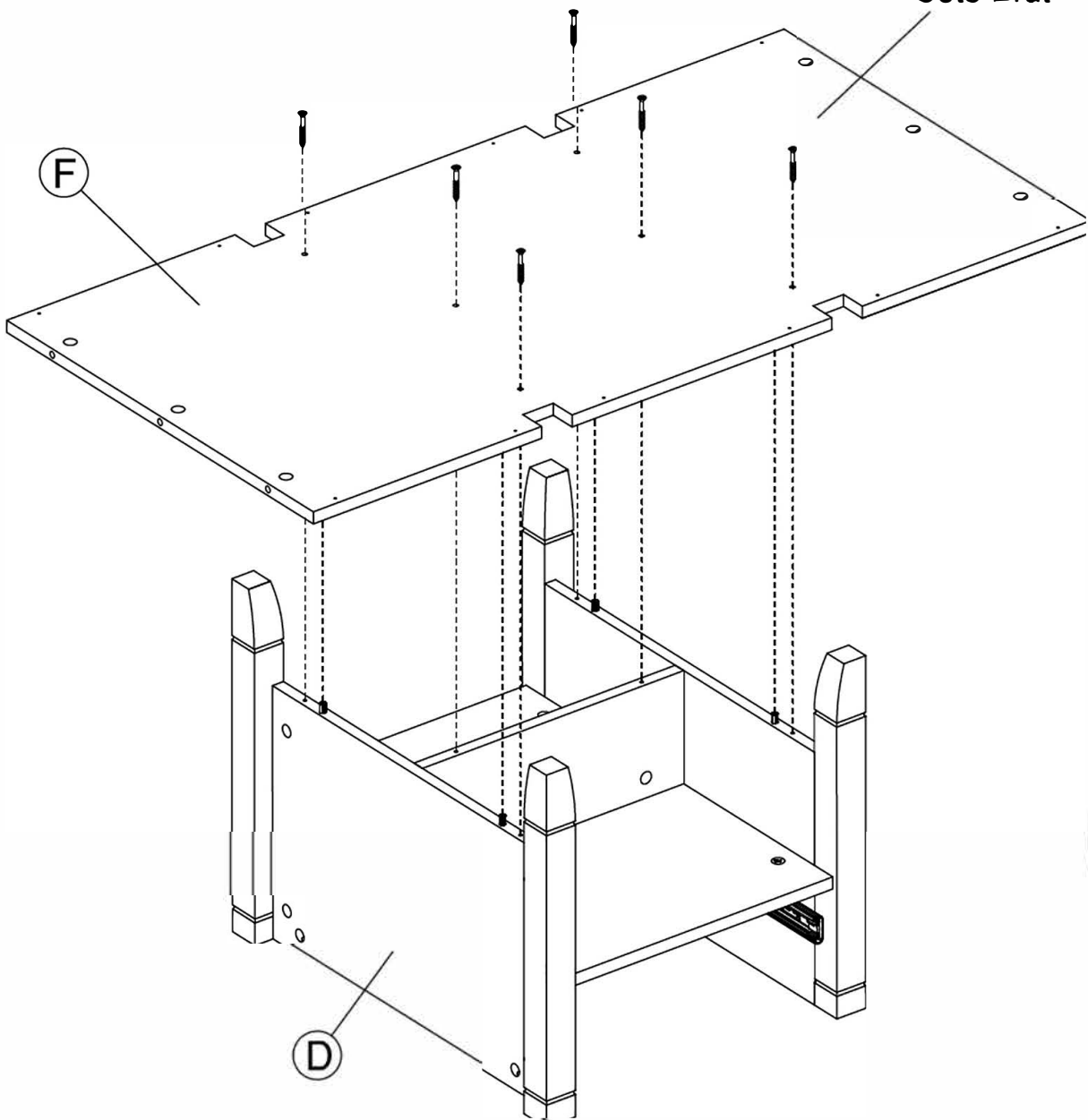

STEP 15

Insert Fasteners

H171556

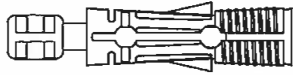

[6]

Quick Connect

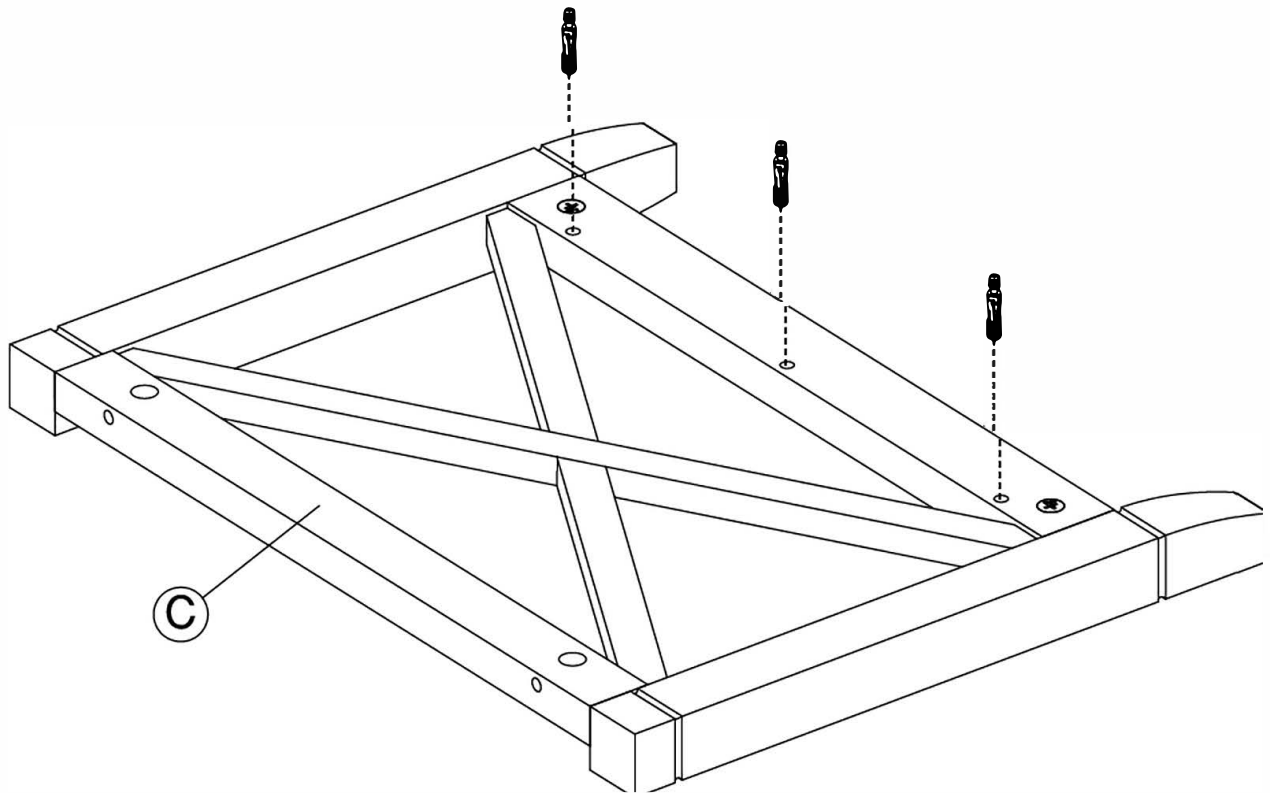

2 X

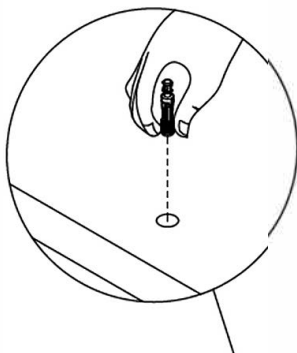

MAY HAVE TO SQUEEZE PLASTIC TO INSERT INTO HOLE.
PUEDE TENER QUE APRETAR PLÁSTICO PARA INSERTAR EN EL AGUJERO.
PEUT AVOIR À PRESSER EN PLASTIQUE À INSÉRER DANS LE TROU.

STEP 16

Assemble Panel

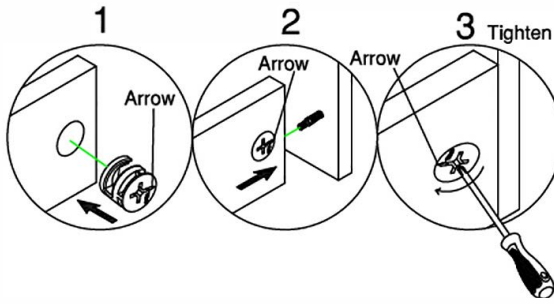

H181468



[3]

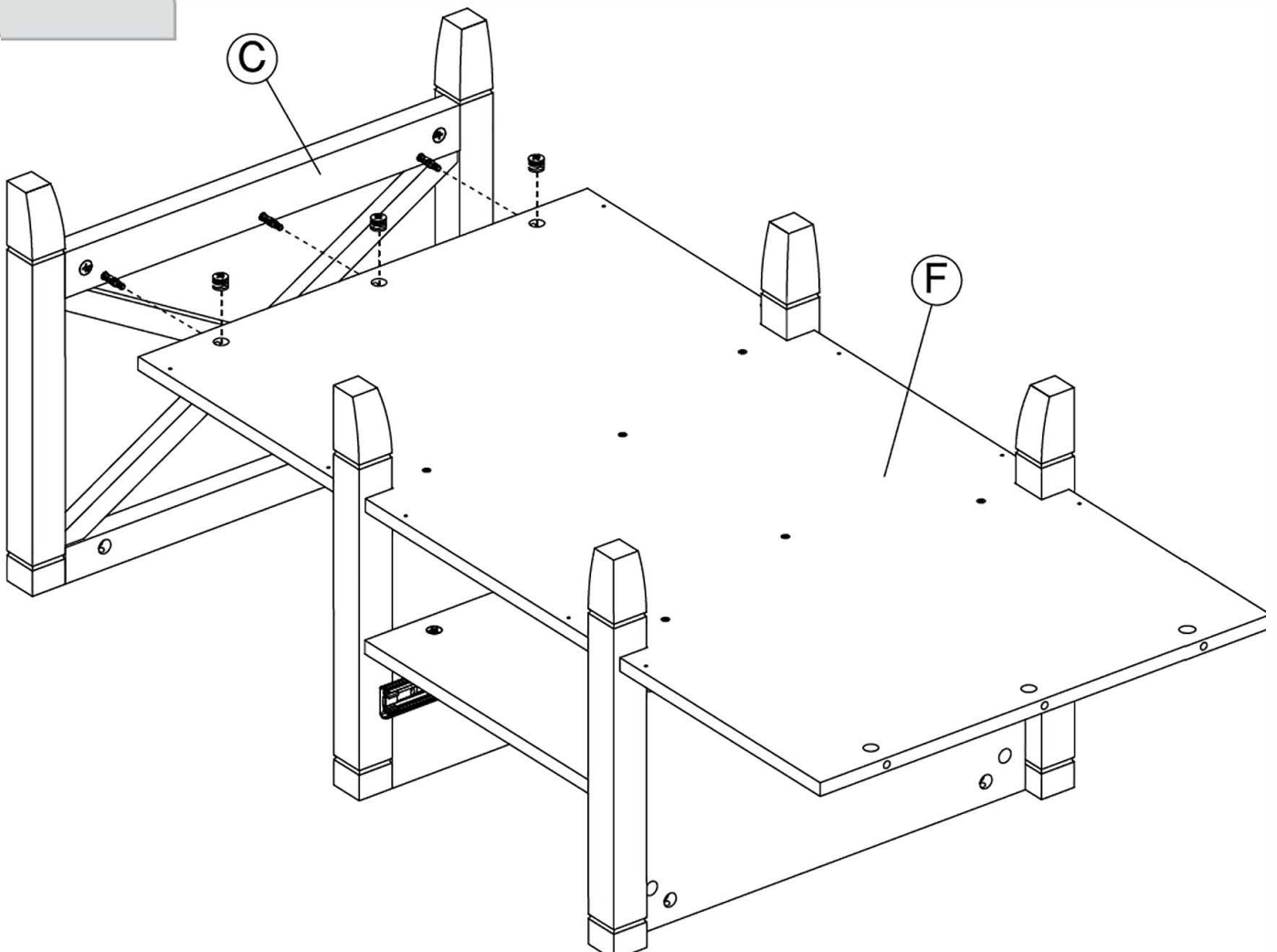

STEP 17

Assemble Panel

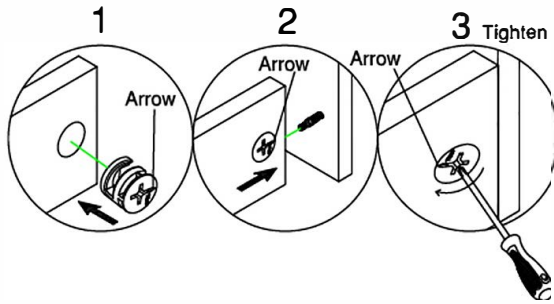

H181468

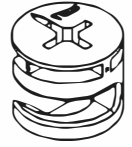

KD Cam

[3]

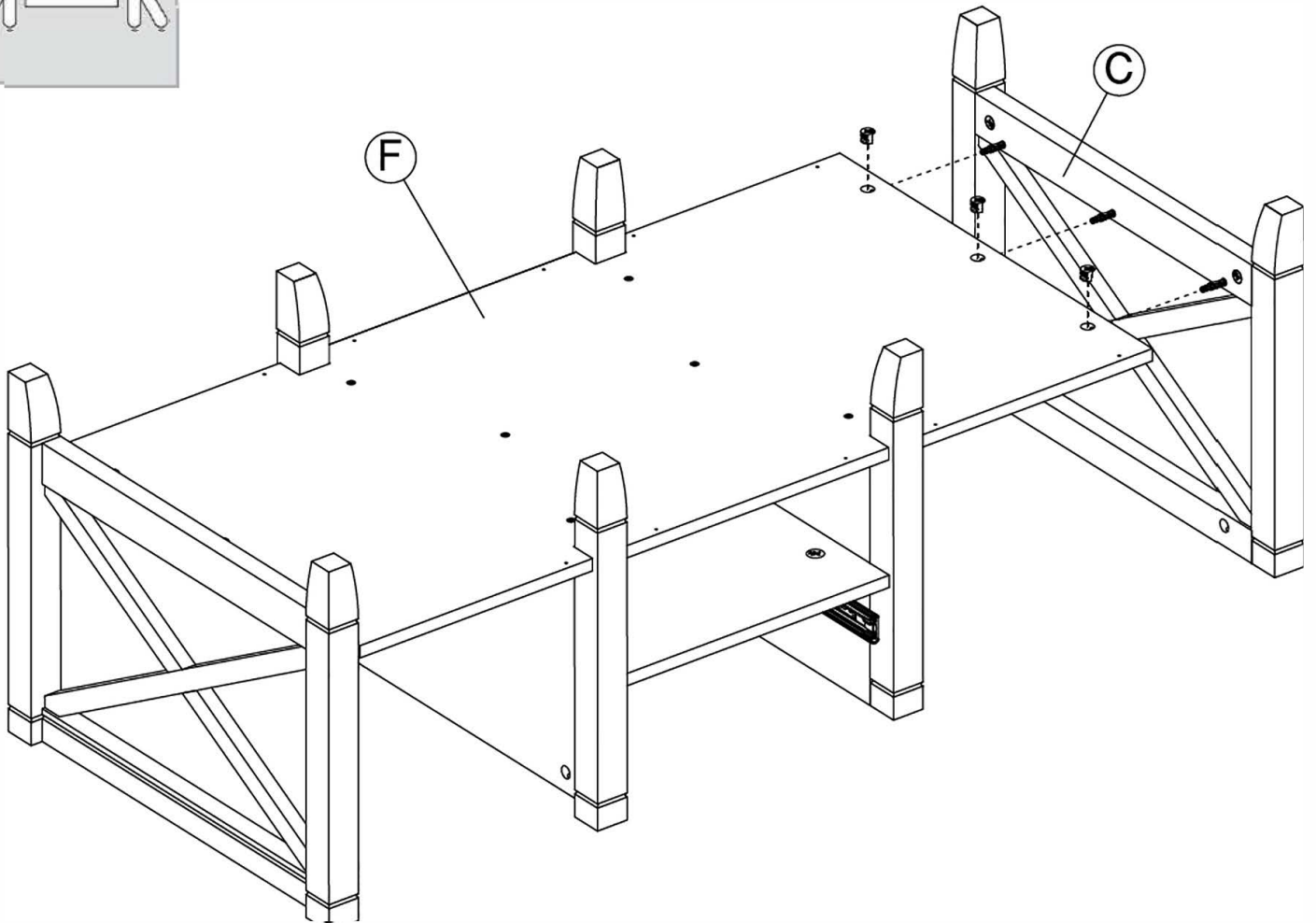

STEP 18

Assemble Rails

H23370



[12]

#10 x 1-1/4"

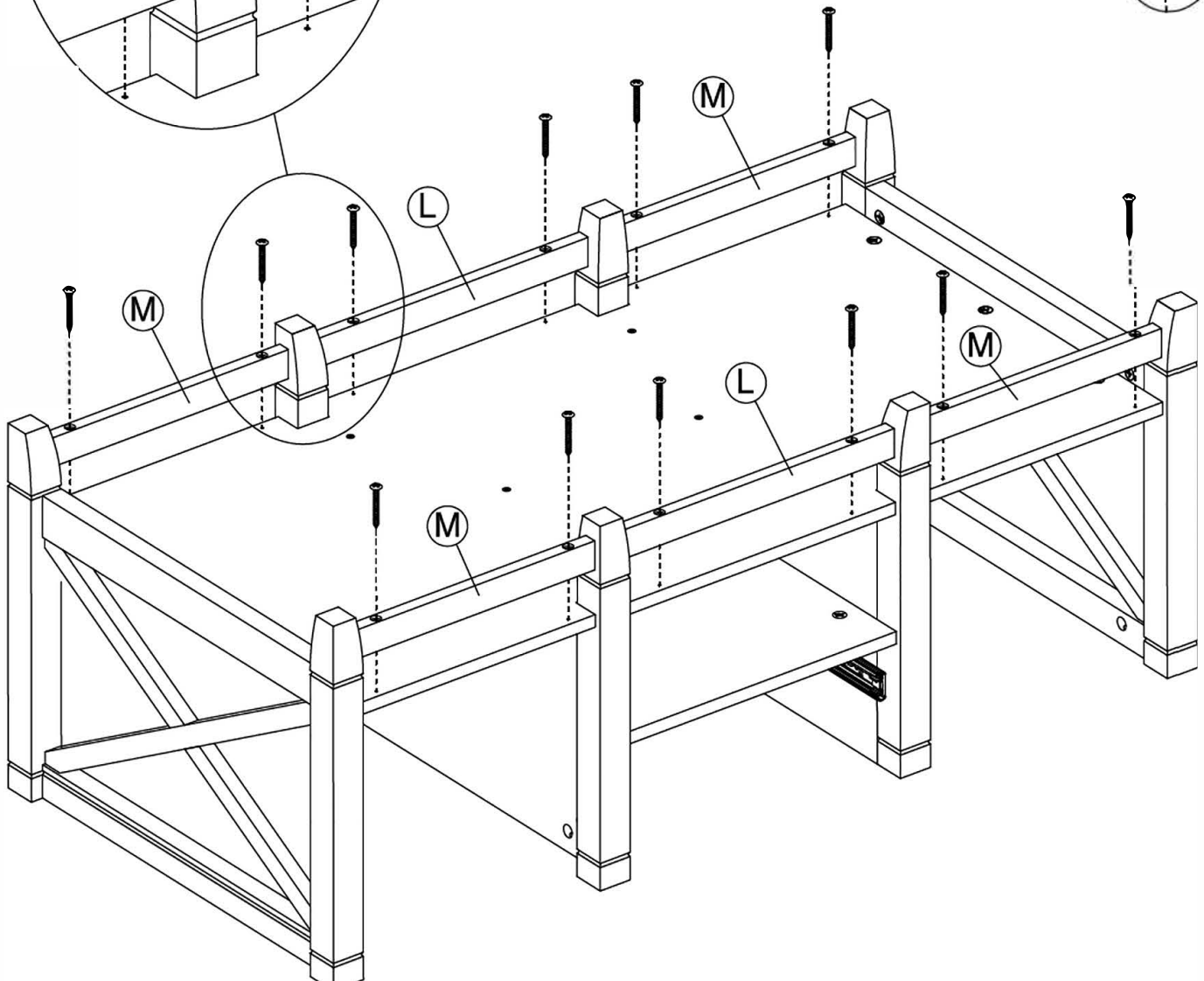
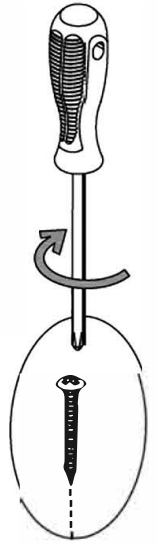
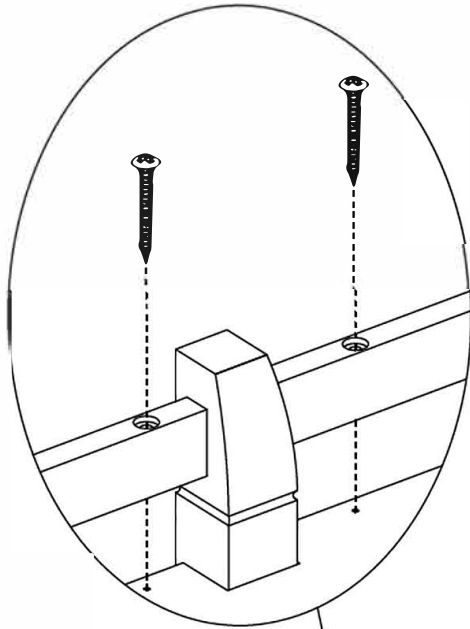

STEP 19

Assemble Panels

H39922



[4]

H35251

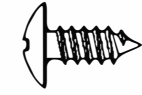

[16]

#10 x 1/2"

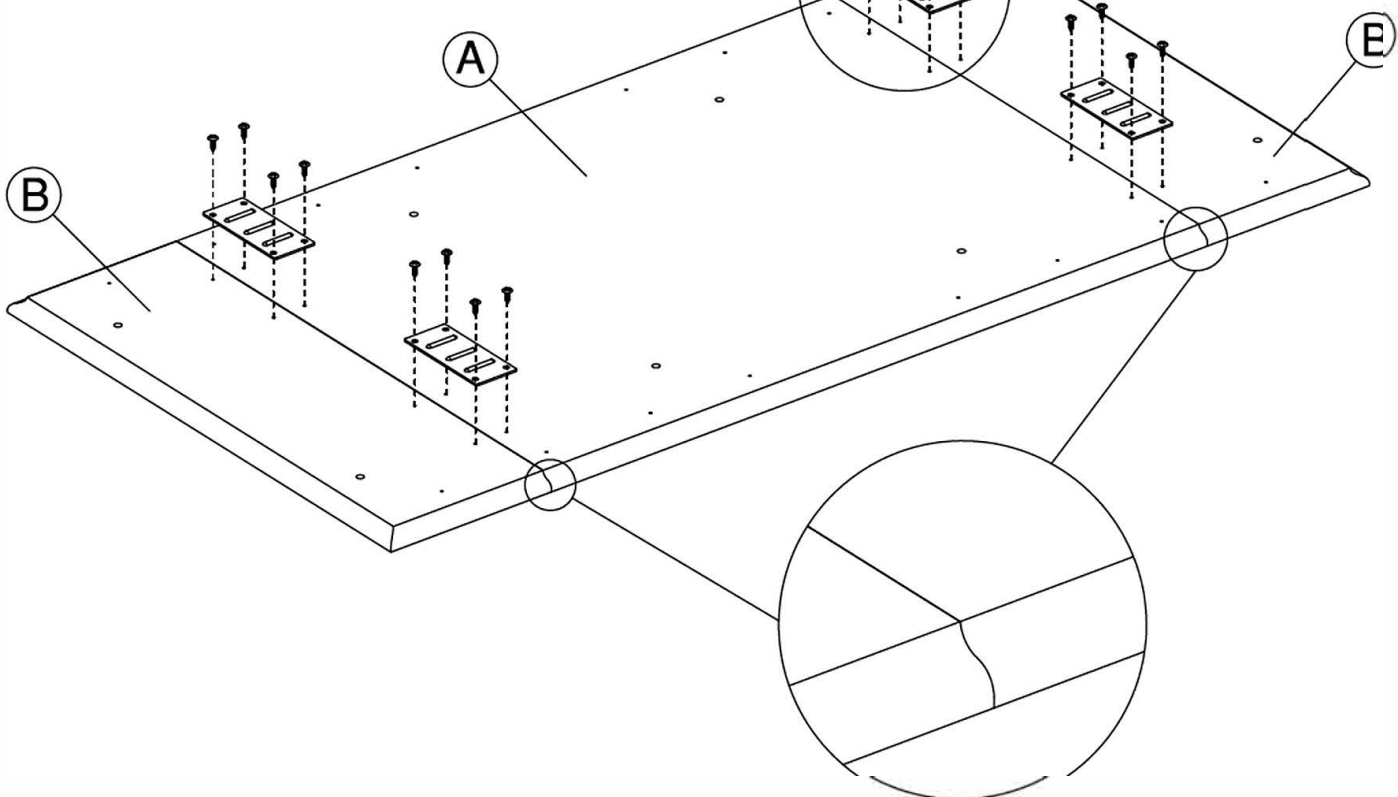
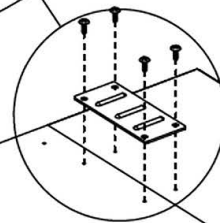
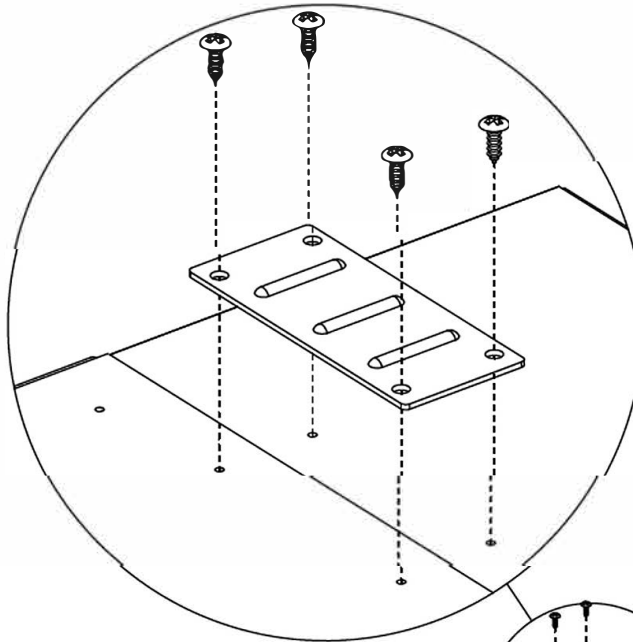
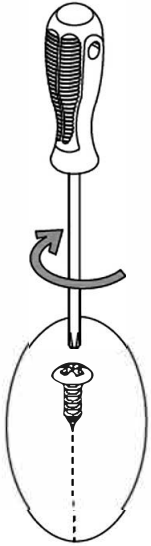

STEP 20

Prepare Rails

H38169



Wood Dowel
8 x 30mm

[2]



Safety glasses
Gafas de seguridad
Lunettes de protection

2 X

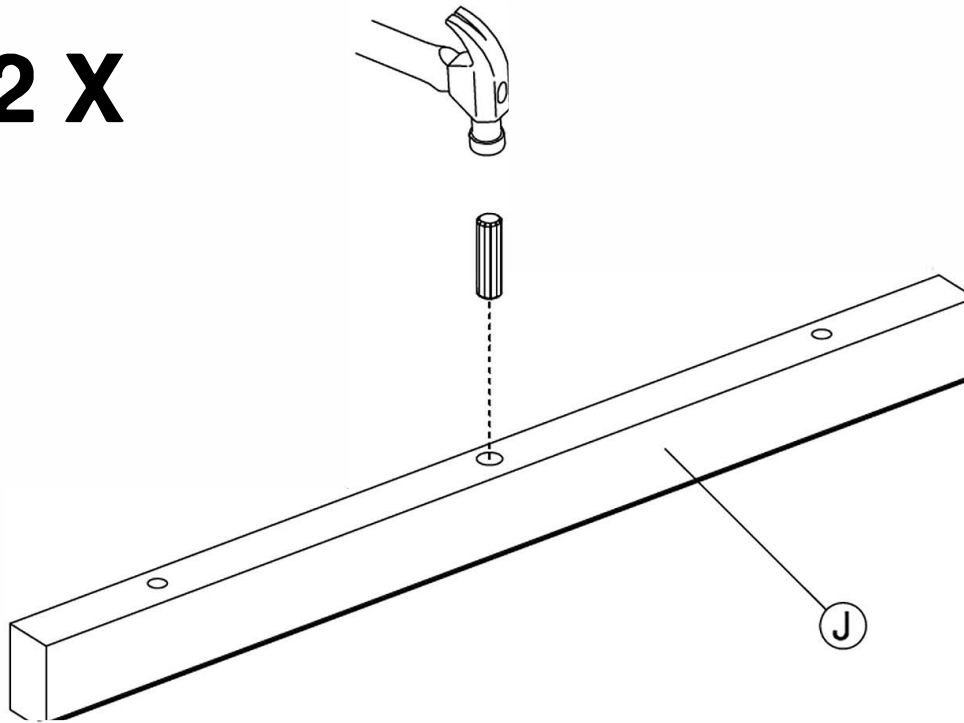

STEP 21

Assemble Rails

H23370



[4]

#10 x 1-1/4"

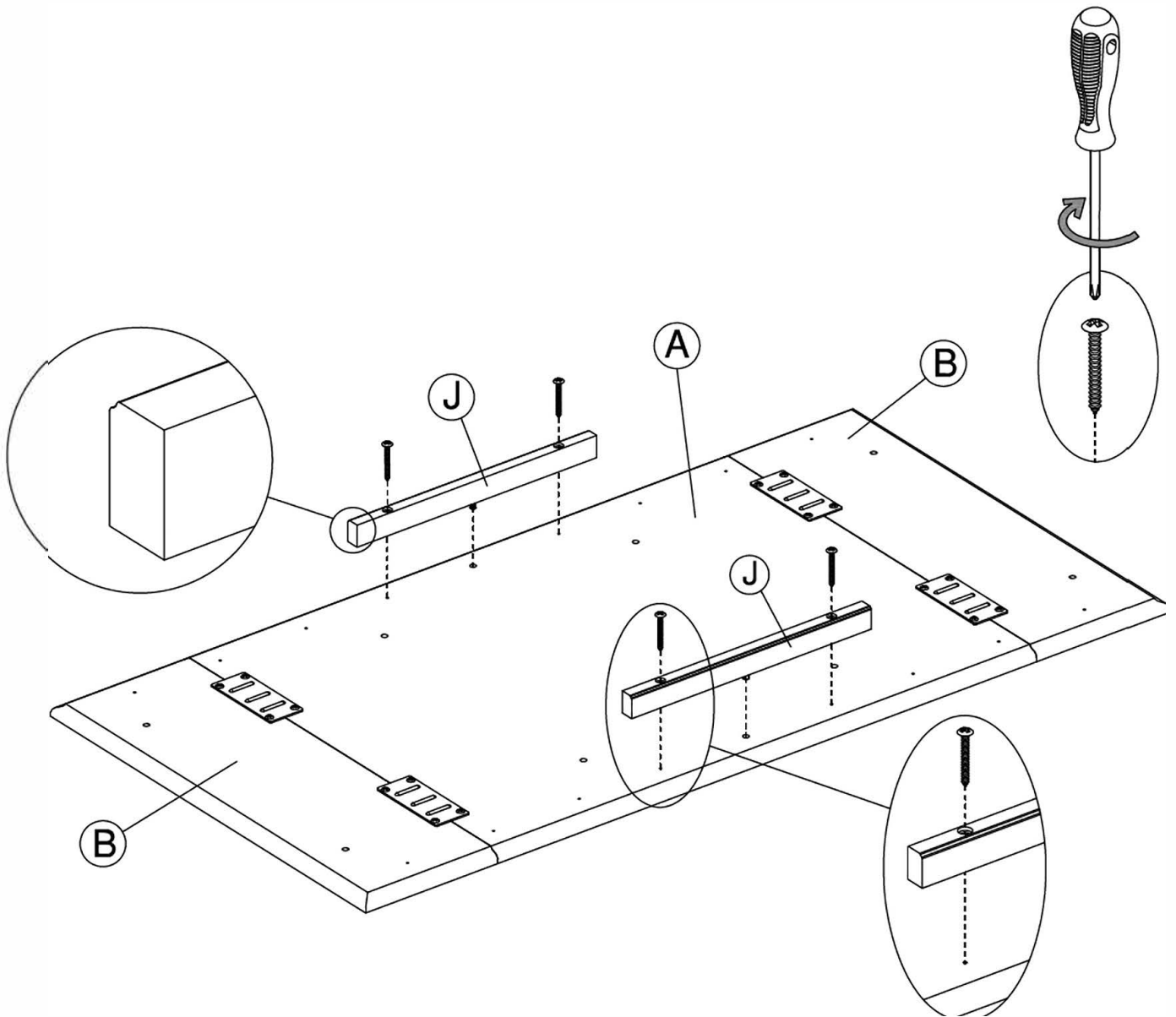

STEP 22

Insert Fasteners

H171556

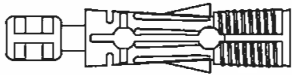

[8]

Quick Connect

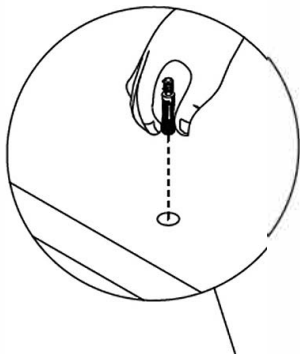
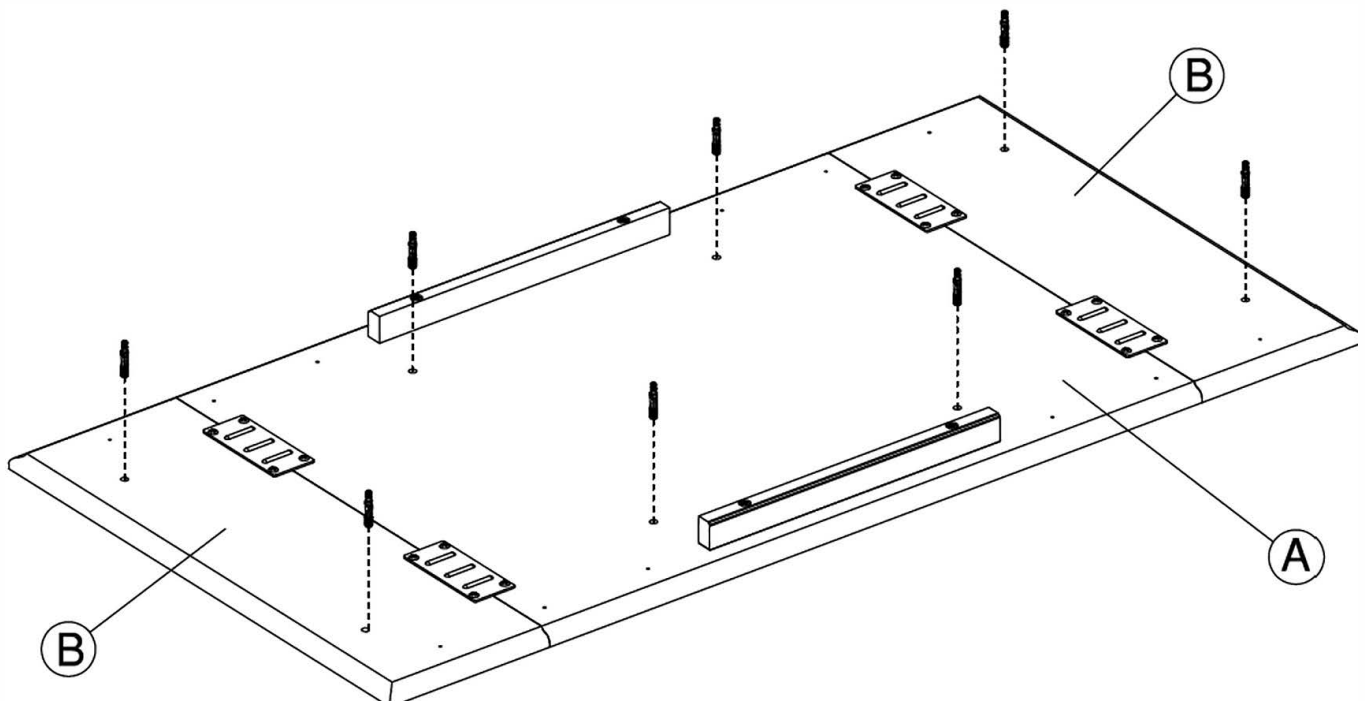

MAY HAVE TO SQUEEZE PLASTIC TO INSERT INTO HOLE.
PUEDE TENER QUE APRETAR PLÁSTICO PARA INSERTAR EN EL AGUJERO.
PEUT AVOIR À PRESSER EN PLASTIQUE À INSÉRER DANS LE TROU.

STEP 23

Assemble Panels

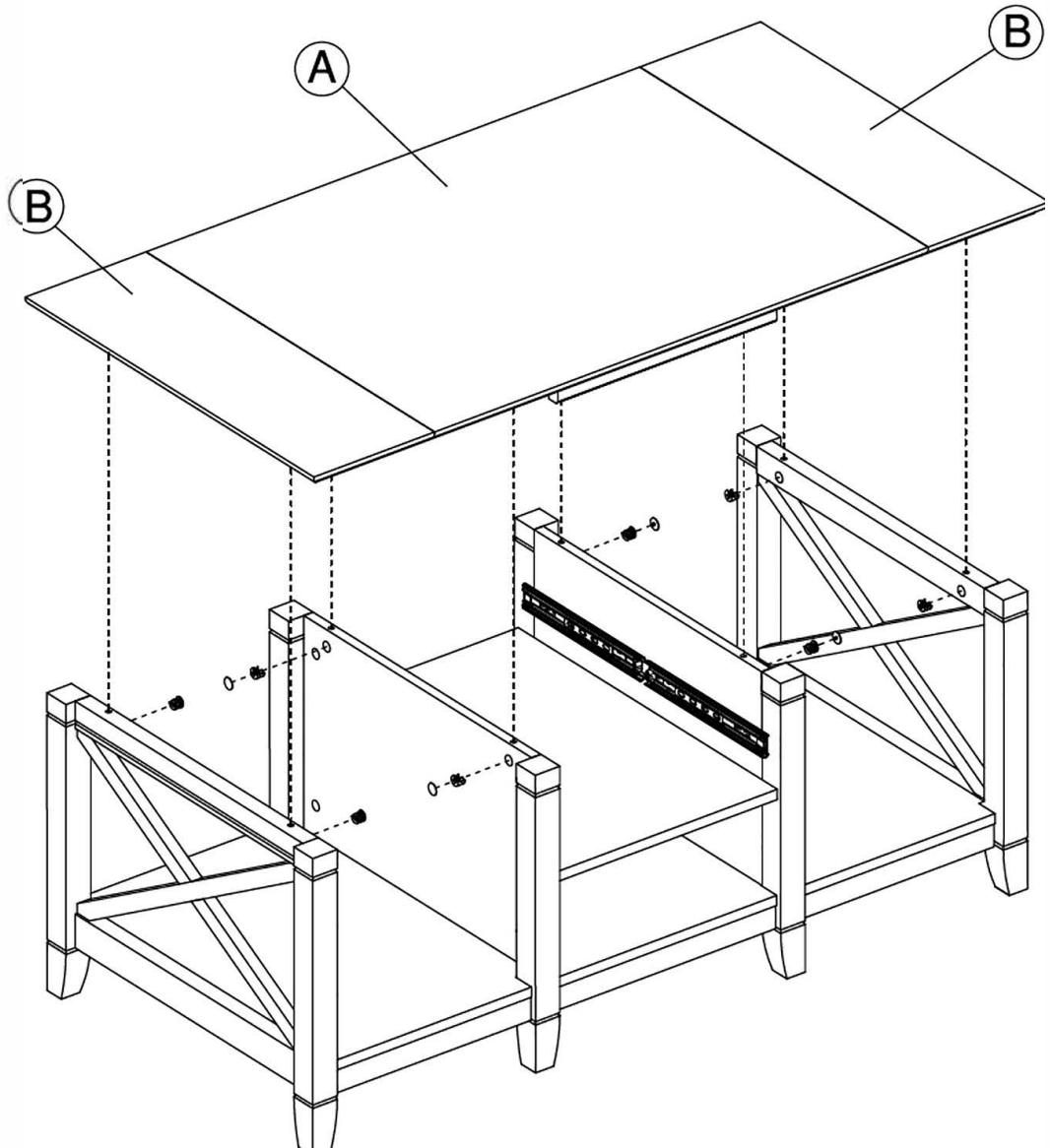
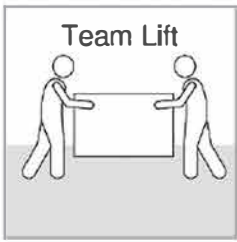
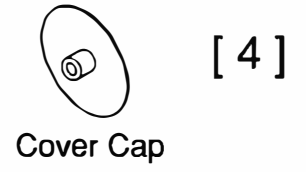
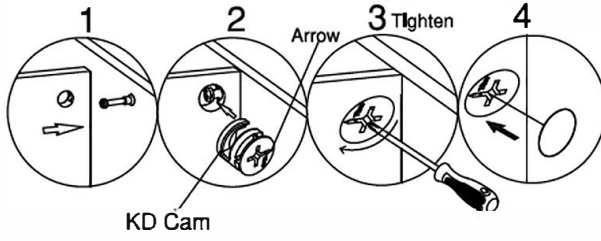

STEP 24

Assemble Panels



H23370



[12]

#10 x 1-1/4"

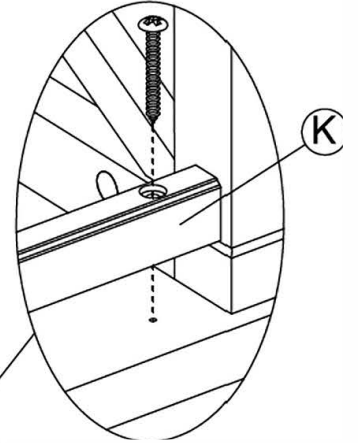
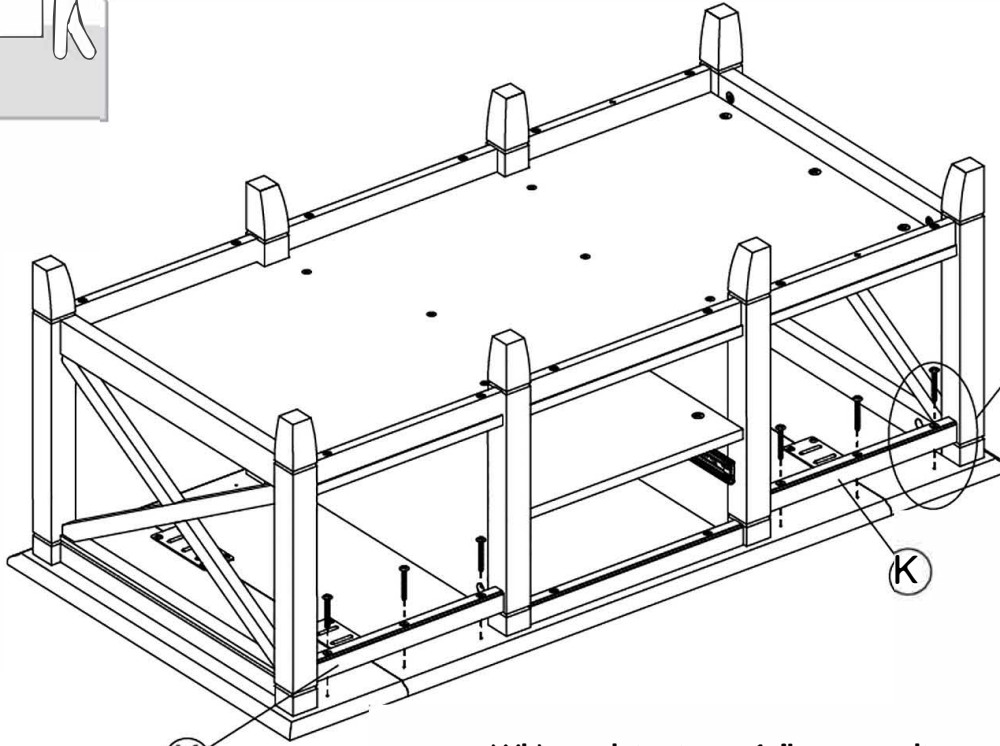

(K)

With assistant carefully turn unit around.

Con la ayuda de un asistente, gire con cuidado el dispositivo.

Avec l'aide de l'assistant, tournez prudemment le dispositif.

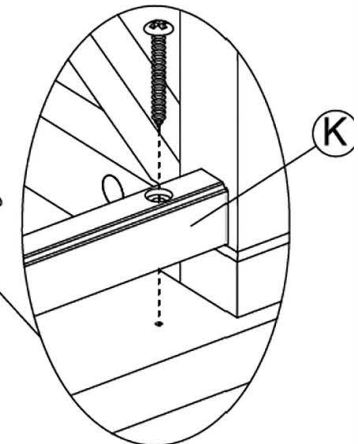
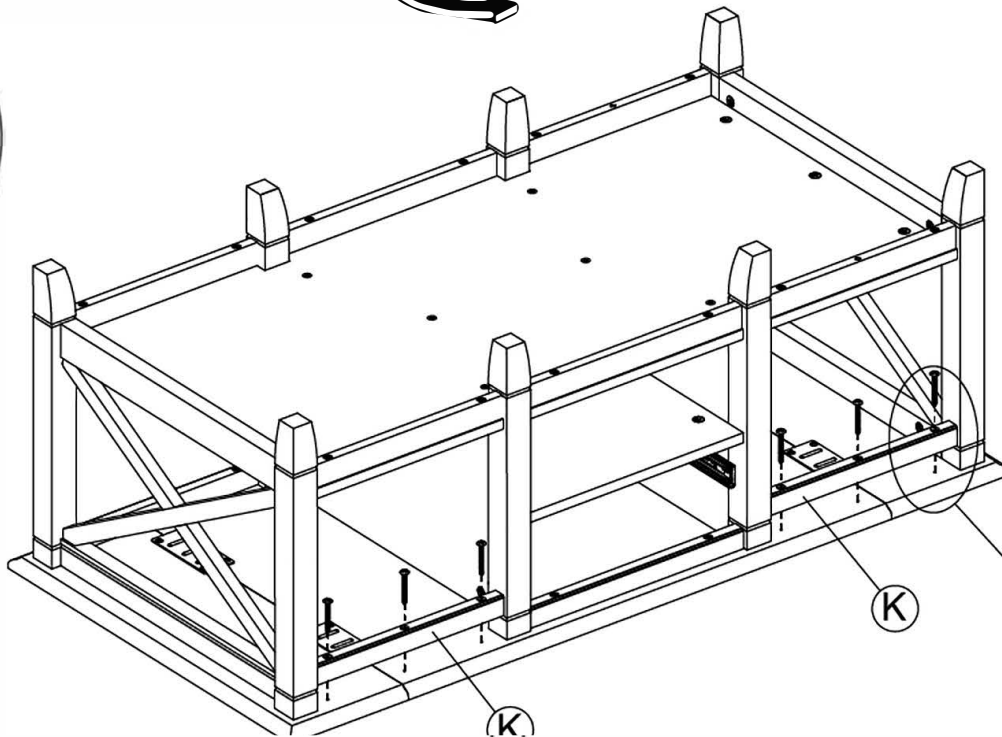
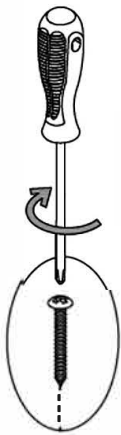

(K)

(K)

STEP 25

Insert Drawers

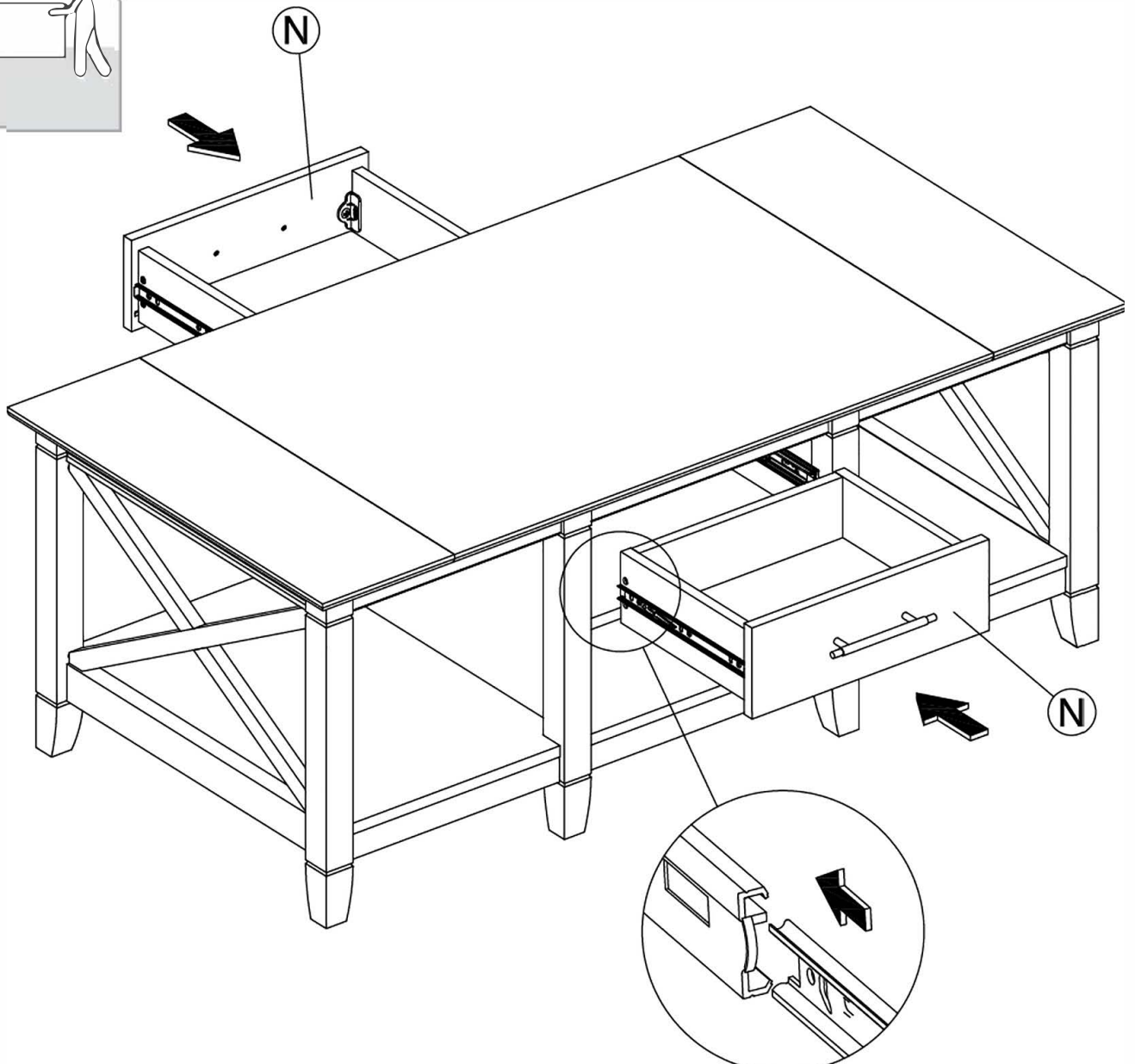

STEP 26

Drawer Adjustment

DRAWER FRONT VIEW

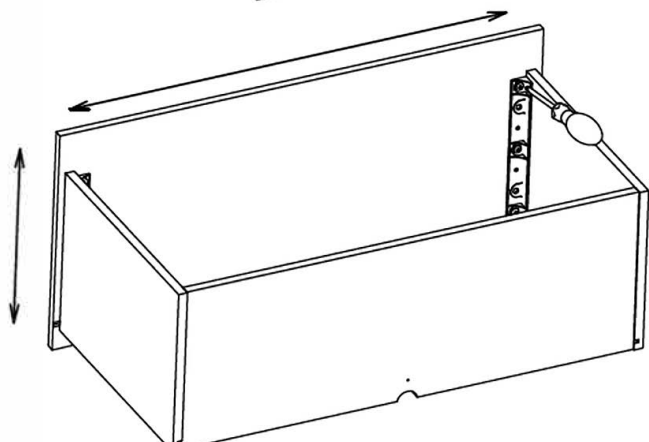
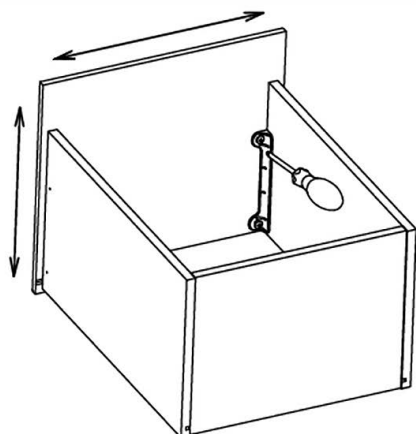
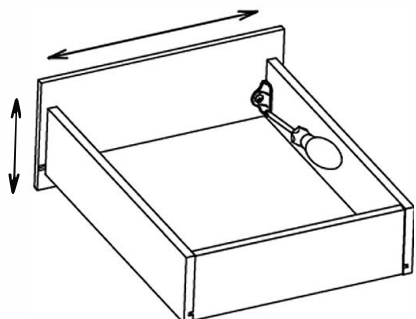
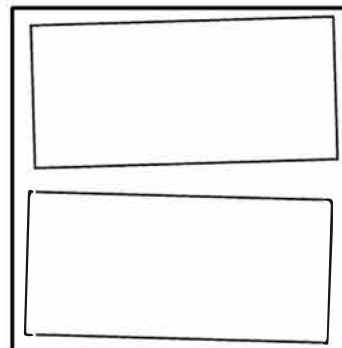
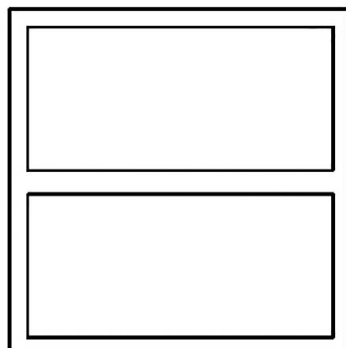

REQUIRED TOOL: PHILLIPS SCREWDRIVER

HERRAMIENTA REQUERIDA: DESTORNILLADOR PHILLIPS
OUTIL REQUIS: TOURNEVIS CRUCIFORME



1. LOOSEN SCREWS.
2. ADJUST DRAWER FRONTS.
3. TIGHTEN SCREWS.

1. Afloje los tornillos
2. Ajustar frentes de cajón
3. Apriete los tornillos

1. Desserrer les vis
2. Ajuster les façades des tiroirs
3. Serrer les vis

STEP 27

Maximum Loading and Cleaning

Gently clean surfaces with a damp sponge eraser.

MAXIMUM WEIGHT: 50 LBS (22.68 KG)
PESO MÁXIMO: 50 LIBRAS (22.68 KILOGRAMO)
POIDS MAXIMUM: 50 LIVRES (22.68 KILOGRAMME)

MAXIMUM WEIGHT: 15 LBS (6.8KG)
PESO MÁXIMO: 15 LIBRAS (6.8KILOGRAMO)
POIDS MAXIMUM: 15LIVRES (6.8 KILOGRAMME)

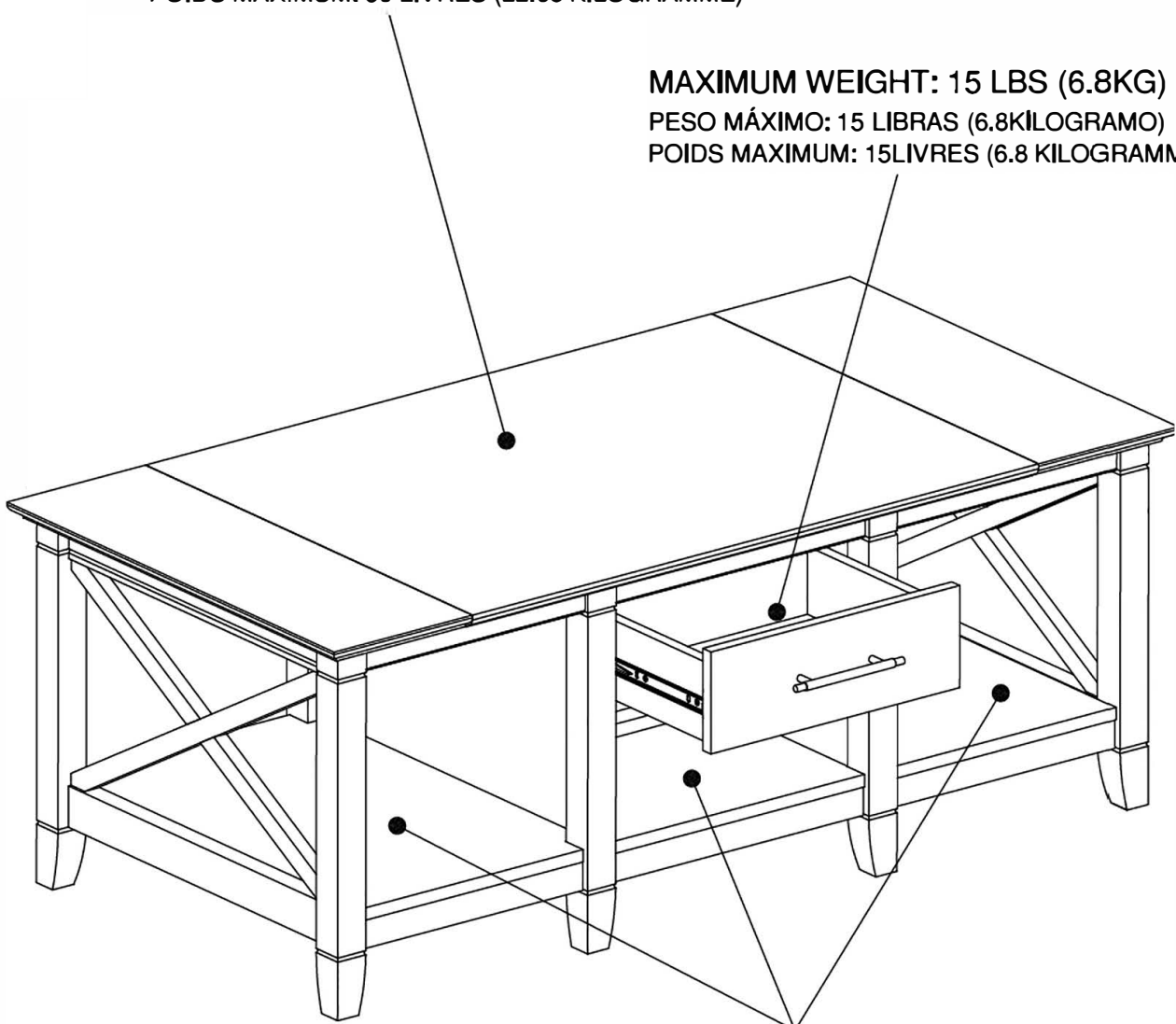

MAXIMUM WEIGHT: 25 LBS (11.34KG)
PESO MÁXIMO: 25 LIBRAS (11.34KILOGRAMO)
POIDS MAXIMUM: 25 LIVRES (11.34 KILOGRAMME)

PARTS LIST

A [1] W197167

B [2] W197168

C [2] S197169

D [2] W197170

E [1] W197171

F [1] W197172

G [1] W197173

H [2] W197174

I [2] W197175

J [2] W197176

K [4] W197177

L [2] W197178

M [4] W197179

N [2] W197180

O [2] W197181

P [2] W197182

Q [2] W197183

R [2] W197184

H200205



Cover Cap

[14]

H200219

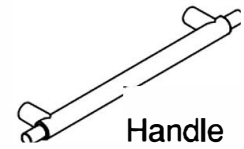

Handle

[2]

A [1] W197185

B [2] W197186

C [2] S197187

D [2] W197188

E [1] W197189

F [1] W197190

G [1] W197191

H [2] W197192

I [2] W197193

J [2] W197194

K [4] W197195

L [2] W197196

M [4] W197197

N [2] W197198

O [2] W197199

P [2] W197200

Q [2] W197201

R [2] W197202

H200199



Cover Cap

[14]

H180971

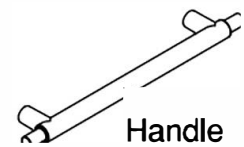

Handle

[2]

PARTS LIST

A [1] W197203	G [1] W197209	M [4] W197215
B [2] W197204	H [2] W197210	N [2] W197216
C [2] S197205	I [2] W197211	O [2] W197217
D [2] W197206	J [2] W197212	P [2] W197218
E [1] W197207	K [4] W197213	Q [2] W197219
F [1] W197208	L [2] W197214	R [2] W197220

H200203



Cover Cap

[14]

H180971

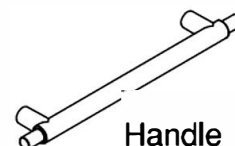

[2]

Handle

A [1] W197221	G [1] W197227	M [4] W197233
B [2] W197222	H [2] W197228	N [2] W197234
C [2] S197223	I [2] W197229	O [2] W197235
D [2] W197224	J [2] W197230	P [2] W197236
E [1] W197225	K [4] W197231	Q [2] W197237
F [1] W197226	L [2] W197232	R [2] W197238

H186180



Cover Cap

[14]

H200219

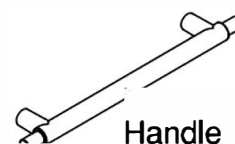

[2]

Handle

PARTS LIST

A [1] W197239

B [2] W197240

C [2] S197241

D [2] W197242

E [1] W197243

F [1] W197244

G [1] W197245

H [2] W197246

I [2] W197247

J [2] W197248

K [4] W197249

L [2] W197250

M [4] W197251

N [2] W197252

O [2] W197253

P [2] W197254

Q [2] W197255

R [2] W197256

H170595



Cover Cap

[14]

H180971

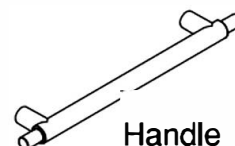

Handle

[2]

A [1] W190434

B [2] W190435

C [2] S190436

D [2] W190437

E [1] W190438

F [1] W190439

G [1] W190440

H [2] W190441

I [2] W190442

J [2] W190443

K [4] W190444

L [2] W190445

M [4] W190446

N [2] W190447

O [2] W190407

P [2] W190408

Q [2] W190448

R [2] W190449

H180730



Cover Cap

[14]

H180971

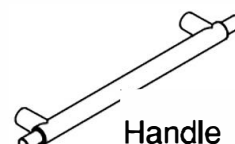

Handle

[2]

WARRANTY INFORMATION/INFORMATIONS POUR LA GARANTIE/INFORMACIÓN DE GARANTÍA

WRITTEN WARRANTY TO YOU

In order to provide you with timely assistance, please thoroughly inspect your furniture for missing or defective parts immediately after opening the carton. You will also need your sales receipt or other proof of purchase. Replacement part(s) will be shipped to you at no charge with assuming all ship-ping and handling charges.

This product is warranted to the original purchaser at the time of purchase and for a period of one year thereafter.

We warrant to you, the original purchaser, that our furniture and all its parts and components are free of defects in material or workmanship. "Defects," as used in this warranty, is defined as any imperfection which impairs the use of the furniture product.

Our warranty is expressly limited to the replacement of furniture parts and components. For one year after the date of purchase, we will replace any parts that are defective in material or workmanship.

This warranty applies under conditions of normal use. Our products are not intended for outdoor use. This warranty does not cover: 1) defects caused by improper assembly or disassembly; 2) defects occurring after purchase due to product modification, intentional damage, accident, misuse, abuse, negligence or exposure to the elements; and 3) labor or assembly costs.

IMPLIED WARRANTIES, INCLUDING THE WARRANTY OF MERCHANTABILITY, SHALL NOT EXTEND BEYOND THE DURATION OF THE WRITTEN WARRANTY STATED ABOVE, AND IN NO EVENT SHALL BE LIABLE FOR INCIDENTAL OR CONSEQUENTIAL DAMAGES RESULTING FROM USE OF THE PRODUCT. Some states do not allow a limitation on how long an implied warranty lasts or the exclusion or limitation of incidental or consequential damages, so the above limitation and exclusion may not apply to you.

This warranty gives you specific legal rights. You may also have other rights that may vary from state to state.

VOTRE GARANTIE

Afin de vous assister rapidement, veuillez inspecter votre mobilier en détail immédiatement après l'ouverture du carton en cas de pièces manquantes ou défectueuses. Vous aurez également besoin de votre reçu ou d'une autre preuve d'achat. La (les) pièce(s) de rechange vous sera (seront) envoyée(s) sans frais, Industries se chargeant de tous les frais d'expédition.

Tout le produit est garanti à l'acheteur original à partir de la date d'achat pour une période d'un an.

Nous vous garantissons, à vous l'acheteur original, que notre mobilier et toutes ses pièces et composants sont sans défaut de matériau ou de fabrication. Le terme "défauts" utilisé dans cette garantie, est défini comme étant toutes les imperfections qui compromettent l'utilisation du meuble.

Notre garantie est expressément limitée au remplacement des pièces et des composants du mobilier. Pendant un an après la date d'achat, remplacera toute pièce défectueuse dans le matériau ou sa fabrication.

Cette garantie d'applique sous des conditions d'utilisation normale. Nos produits ne sont pas destinés à être utilisés en plein air. Cette garantie ne couvre pas: 1) les défauts causés par un mauvais assemblage ou démontage, 2) les défauts ayant lieu après l'achat et dus à la modification du produit, des dommages intentionnels, des accidents, une mauvaise utilisation, un mauvais traitement, la négligence ou l'exposition aux éléments, et 3) les frais de main d'œuvre ou d'assemblage.

LES GARANTIES TACITES, Y COMPRIS LA GARANTIE DE QUALITE MARCHANDE, NE S'ETENDRONT PAS AU-DELA DE LA DUREE ECRITE CITEE CI-DESSUS, ET NE SERA EN AUCUN CAS RESPONSABLE DES DOMMAGES ACCESSOIRES OU INDIRECTS RESULTANT DE L'UTILISATION DU PRODUIT. Certains états ne permettent pas d'appliquer une limite à la durée de la garantie tacite, ni une exclusion ou limitation des dommages accessoires ou indirects; dans ce cas les limitations ou exclusion ci-dessus peuvent ne pas s'appliquer à vous.

Cette garantie vous donne des droits légaux spécifiques. Il se peut que vous ayez également d'autres droits qui peuvent varier d'un état à l'autre.

GARANTIA ESCRITA DE PARA USTED

Para brindarle asistencia oportuna, por favor, verifique detalladamente que a su mueble no le falte o tenga piezas defectuosas inmediatamente después de abrir la caja. La(s) pieza(s) de reemplazo le será(n) enviada(s) sin recargo por Industrias asumiendo los gas-tos de envío y manipuleo.

Todo mueble es garantizado al comprador original al momento de la compra y por un periodo de uno año en adelante.

Le garantizamos a usted, el comprador original, que nuestros muebles sus partes y componentes están libres de defectos en materiales o trabajo. "Defectos", según se usa en esta garantía, se define como una imperfección que perjudica el uso del producto mobiliario.

Nuestra garantía se limita expresamente al reemplazo de partes y componentes mobiliarios. Durante uno año después de la fecha de compra, reemplazará cualquier parte defectuosa en material o trabajo.

Esta garantía se aplica bajo condiciones de uso normal. Nuestros productos de no son para uso en exteriores. Esta garantía no cubre: 1) defectos causados por un ensamblaje

o desensamblaje inadecuado; 2) defectos que ocurran después de la compra debido a modificación del producto, daño intencional, accidente, mal uso, abuso, negligencia o exposición a los elementos; y 3) costos de trabajo o ensamblaje.

LAS GARANTÍAS IMPLICADAS, INCLUYENDO LA GARANTÍA DE COMERCIABILIDAD, NO SE EXTENDERÁN MÁS ALLÁ DE LA DURACIÓN DE LA GARANTÍA ESCRITA MENCIONADA, Y EN NINGÚN CASO SERÁ RESPONSABLE POR DAÑOS INCIDENTALES O CONSIGUIENTES COMO RESULTADO DEL USO DEL PRODUCTO. Algunos estados no permiten una limitación sobre el tiempo de duración de la garantía implicada o la exclusión o limitación de daños incidentales o consiguientes, de manera que la limitación y exclusión mencionadas pueden no aplicarse para usted.

Esta garantía le otorga derechos legales específicos. Puede también tener otros derechos que pueden variar según los estados.