

ASSEMBLY INSTRUCTIONS

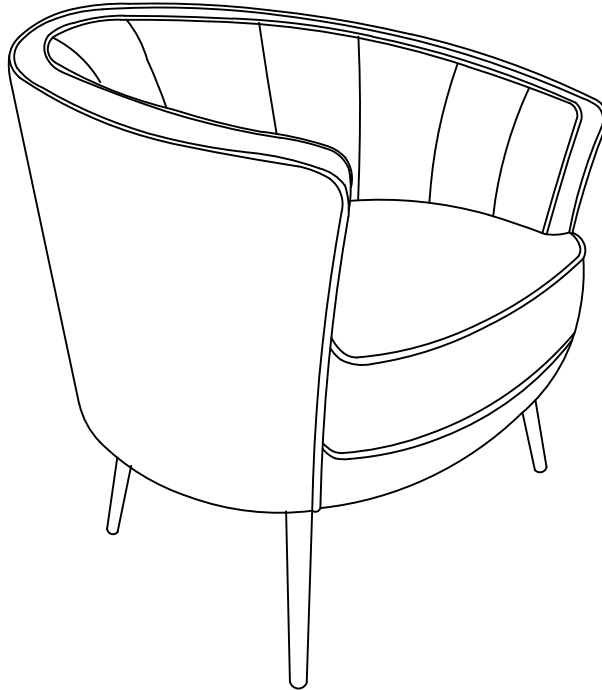

IMPORTANT NOTE

****PLACE ALL PARTS ON A CLEAN AND SMOOTH SURFACE SUCH AS A RUG OR CARPET TO AVOID THE PARTS FROM BEING SCRATCHED**

**** BEFORE YOU BEGIN , KINDY FOLLOW THE ASSEMBLY INSTRUCTIONS STEP BY STEP**

****DO NOT TIGHTEN ALL BOLTS UNTIL THE CHAIR IS FULLY SET-UP**

ASSEMBLY INSTRUCTIONS

PARTS IDENTIFICATION

B1(BOX1)

1 Chair Cusion

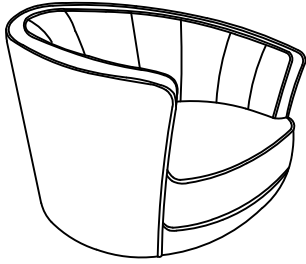

1pc

2 Leg

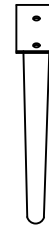

4pcs

HARDWARE IDENTIFICATION

A

Bolt
(Ø 5/16 "X25mm)



8pcs

B

Spring Washer
(Ø 5/16 "-RBW)



8pcs

C

Flat Washer
(Ø 5/16 "-RBW)



8pcs

D

Allen Wrench
(M4x75mm x32mm)





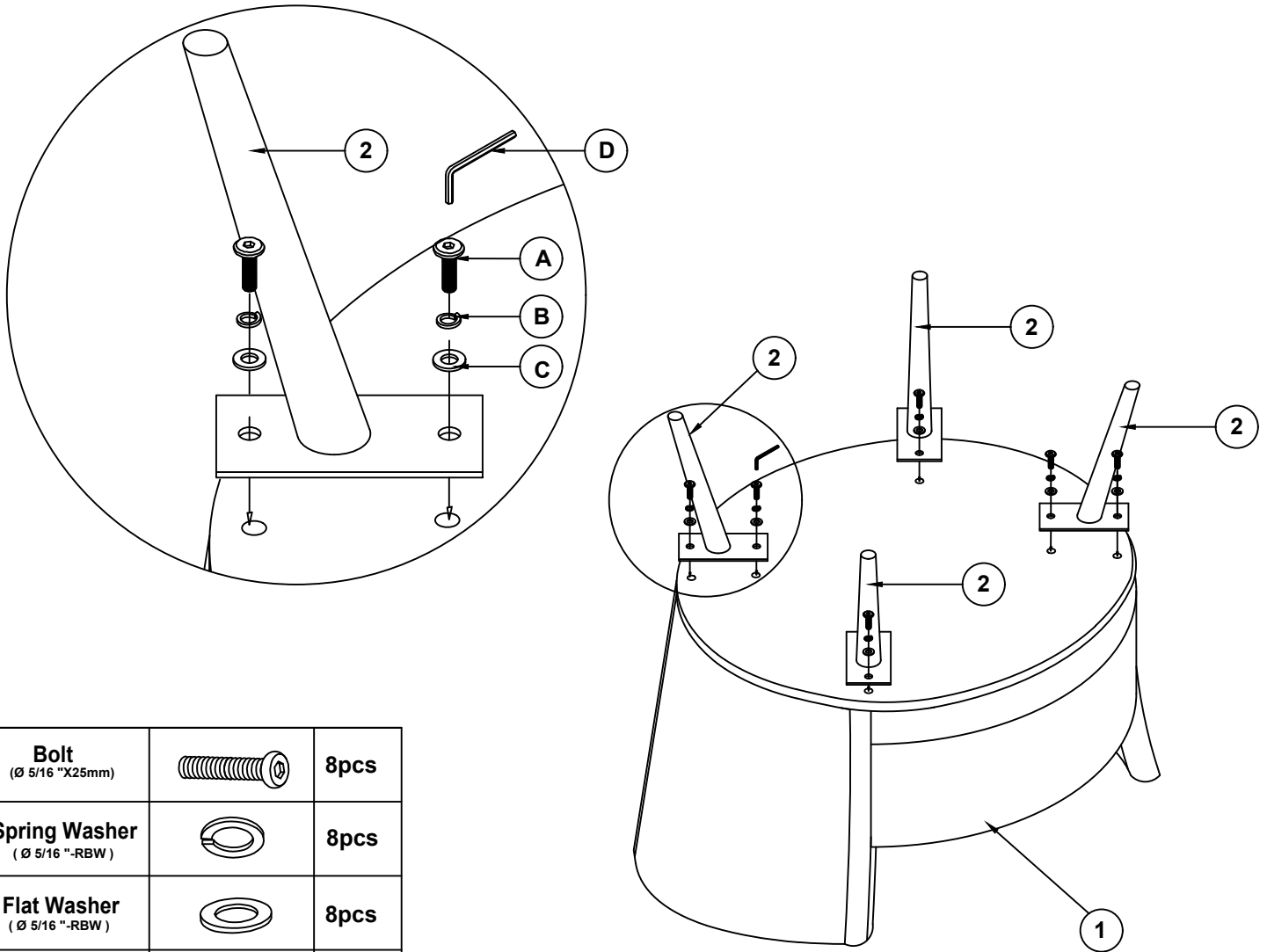

1pc

ASSEMBLY INSTRUCTIONS

STEP 1



| | | | |
|----------|--|---|-------------|
| A | Bolt (Ø 5/16 "X25mm) |  | 8pcs |
| B | Spring Washer (Ø 5/16 "-RBW) |  | 8pcs |
| C | Flat Washer (Ø 5/16 "-RBW) |  | 8pcs |
| D | Allen Wrench (M4x75mm x32mm) |  | 1pc |

Step 2 : Completed Assembly .

