

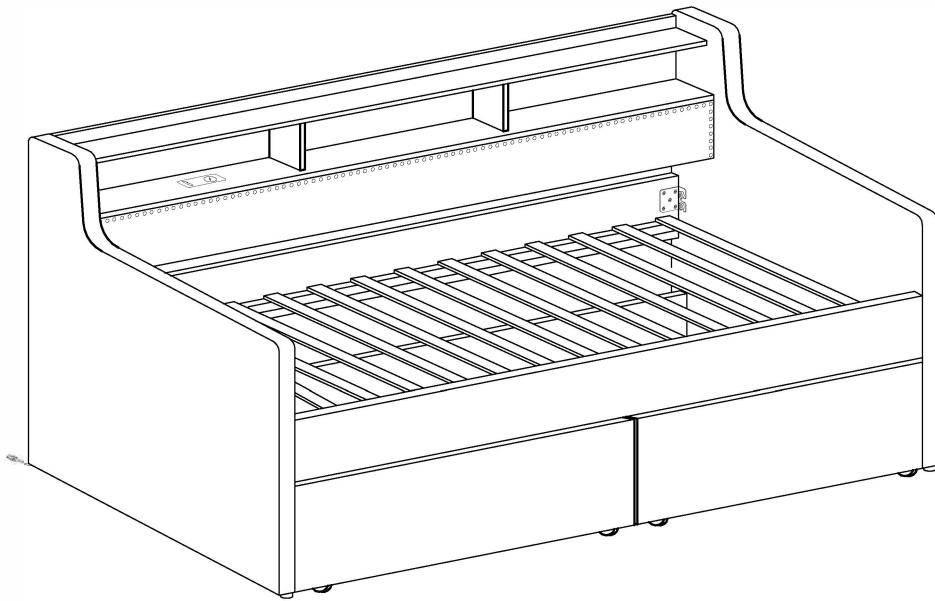









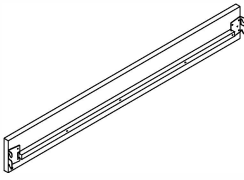
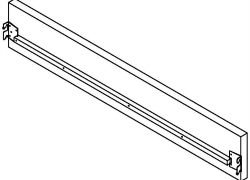

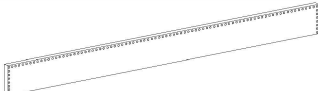
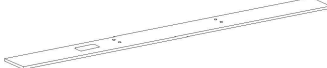
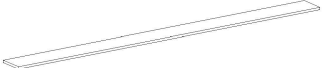
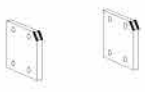

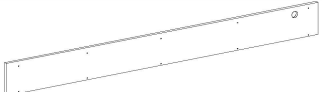
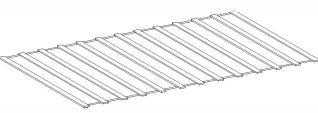

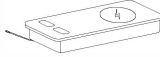







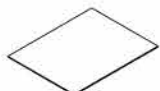



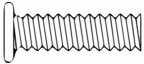

ASSEMBLY INSTRUCTION

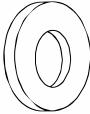

PARTS LIST

 A: 1pc	 B: 1pc	 C: 1pc	 D: 1pc
 E: 1pc	 F: 1pc	 G: 1pc	 H: 1pc
 I: 2pcs	 J: 4pcs	 K: 2pcs	 L: 1pc
 M: 13pcs	 N: 4pcs		
 O: 1pc	 P: LED light belt 1set		
 Q: 2pcs	 R: 2pcs	 S: 2pcs	 T: 2pcs
 U: 2pcs	 V: 8pcs	 W: 2pcs	 X: 1pc

HARDWARE LIST

 M8*30mm 1: 12pcs	 M8*50mm 2: 2pcs	 M6*15mm 3: 22pcs	 M6*32mm 4: 6pcs
 M8 5: 12pcs	 M8*16mm 6: 12pcs	 M6*16mm 7: 28pcs	 M8 8: 1pc
 M6 9: 1pc	 10: 20pcs	 11: 20pcs	 8*30mm 12: 34pcs
 8*15mm 13: 32pcs	 14: 1pc		

STEP 1:

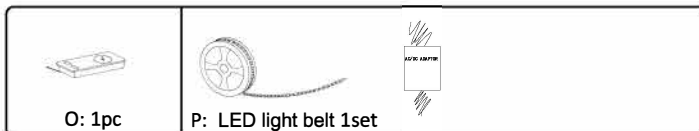

(o)&(p) Please refer to the appendix for details of installation and usage.

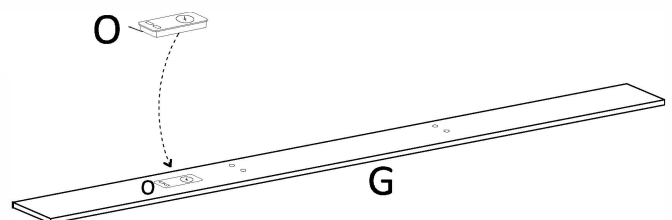
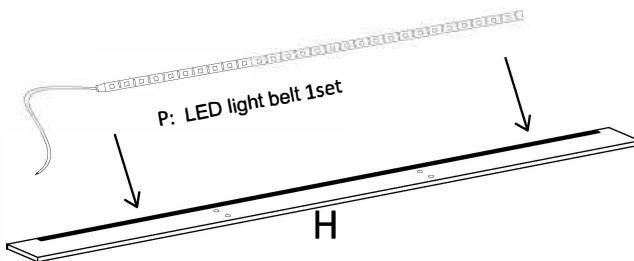

Assembly Steps

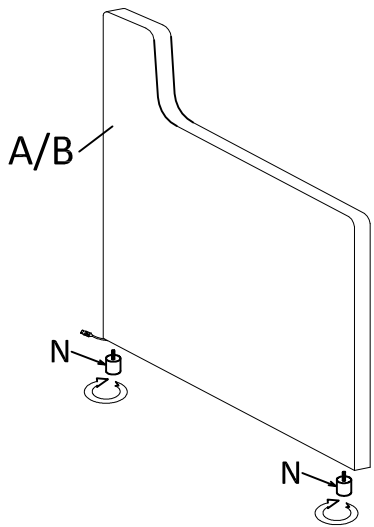

STEP 2:



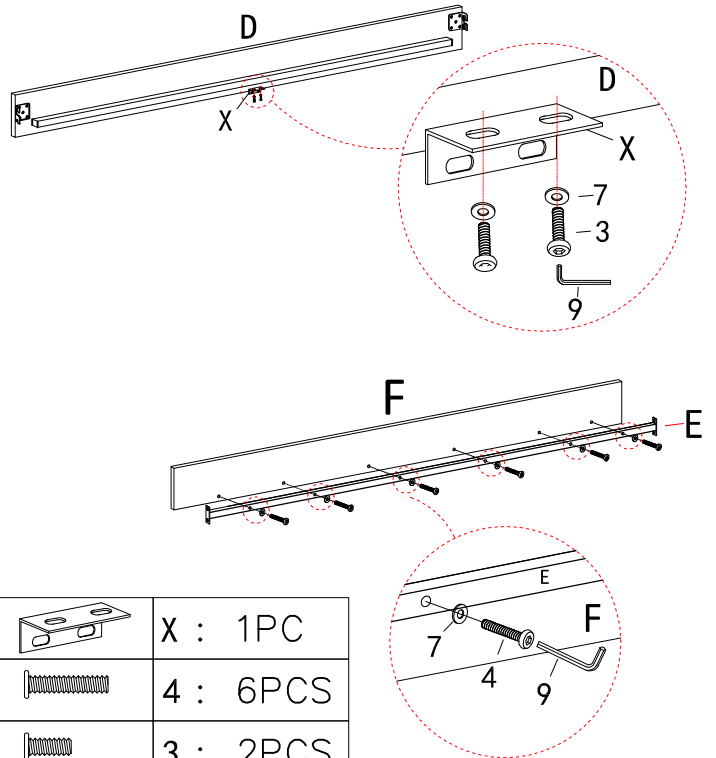

N: 4pcs

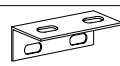
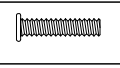
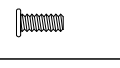
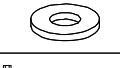



STEP 3:

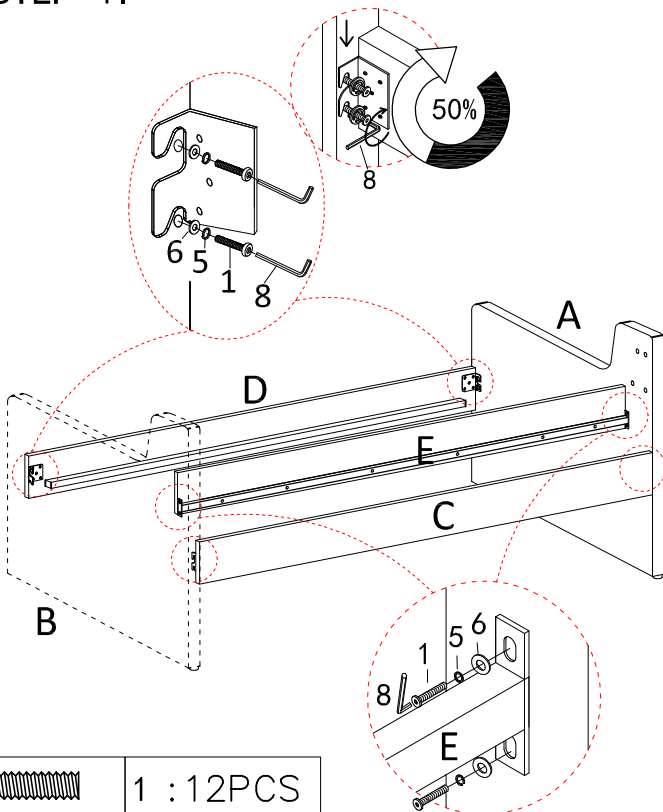

	X : 1PC
	4 : 6PCS
	3 : 2PCS
	7 : 8PCS
	9 : 1PC

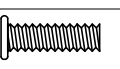

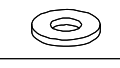
STEP 4:

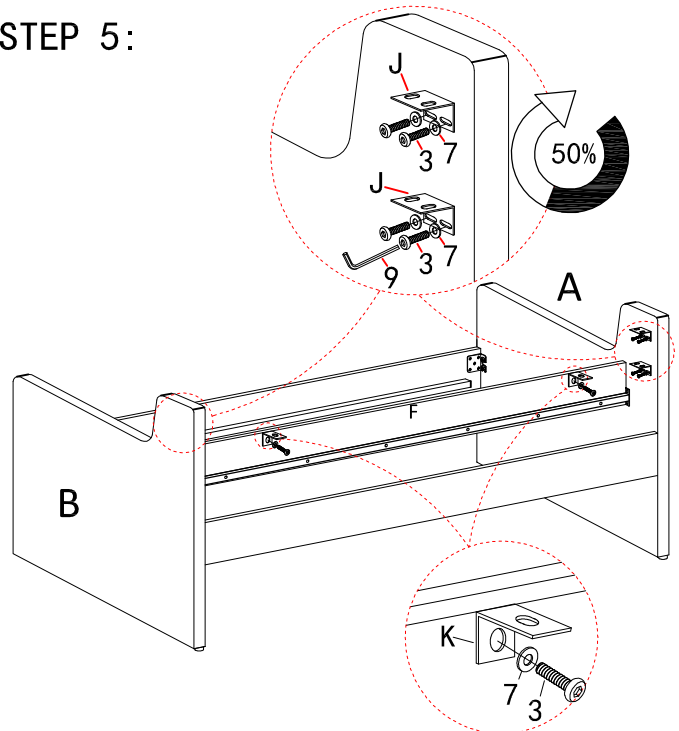

	1 : 12PCS
	8 : 1PC
	6 : 12PCS
	5 : 12PCS

STEP 5:

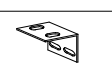
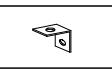
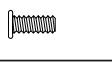
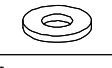

	J : 4PCS
	K : 2PCS
	3 : 10PCS
	7 : 10PCS
	9 : 1PC

Assembly Steps

STEP 6:

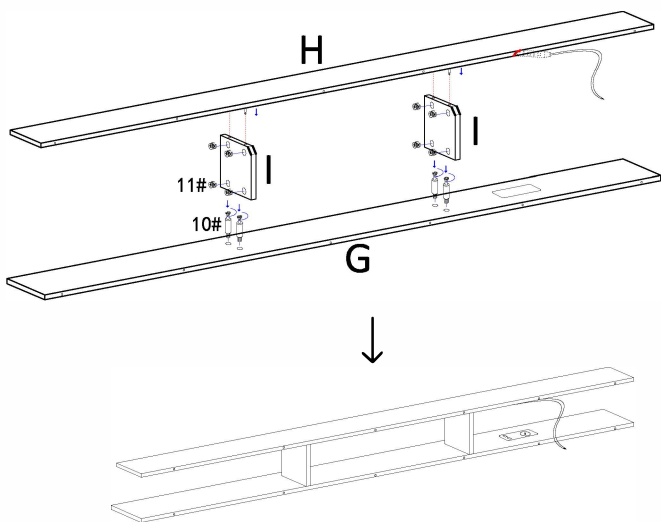
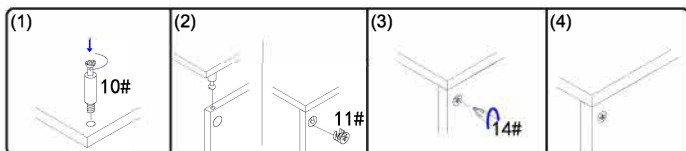

	10: 8PCS
	11: 8PCS
	14: 1PC

STEP 7:

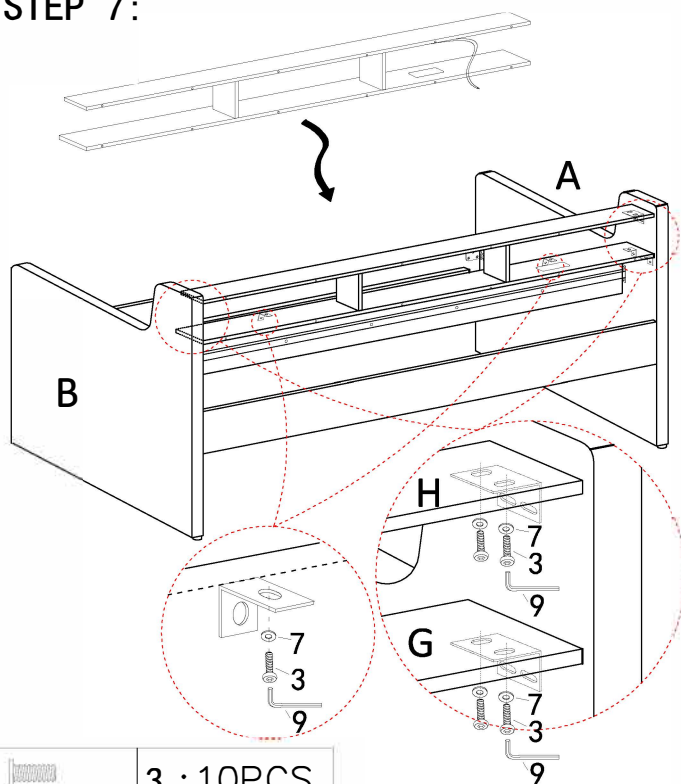

	7 : 10PCS
	3 : 10PCS
	9 : 1PC

STEP 8:

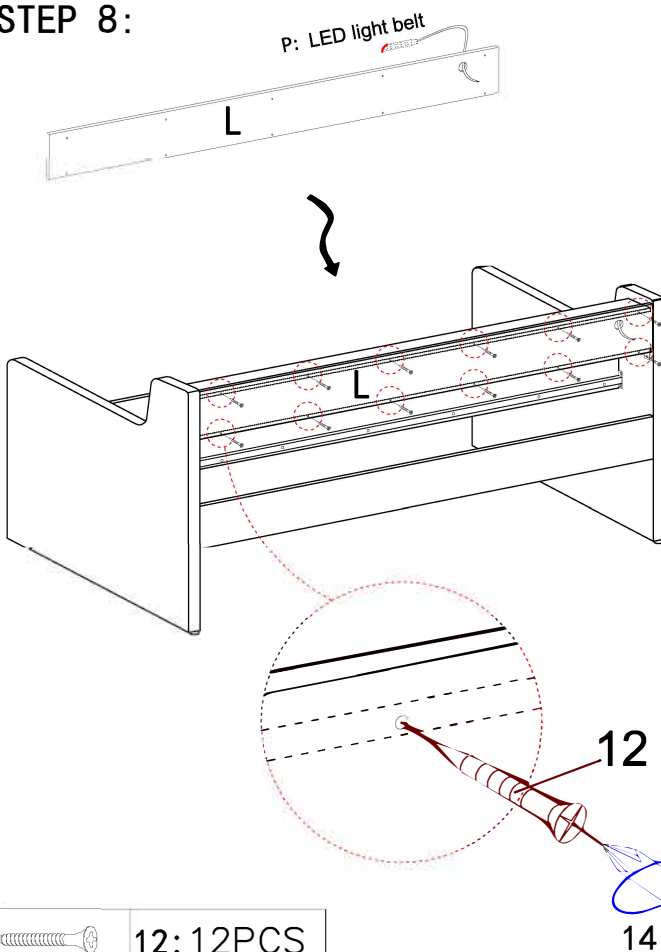

	12: 12PCS
	14: 1PC

STEP 9:

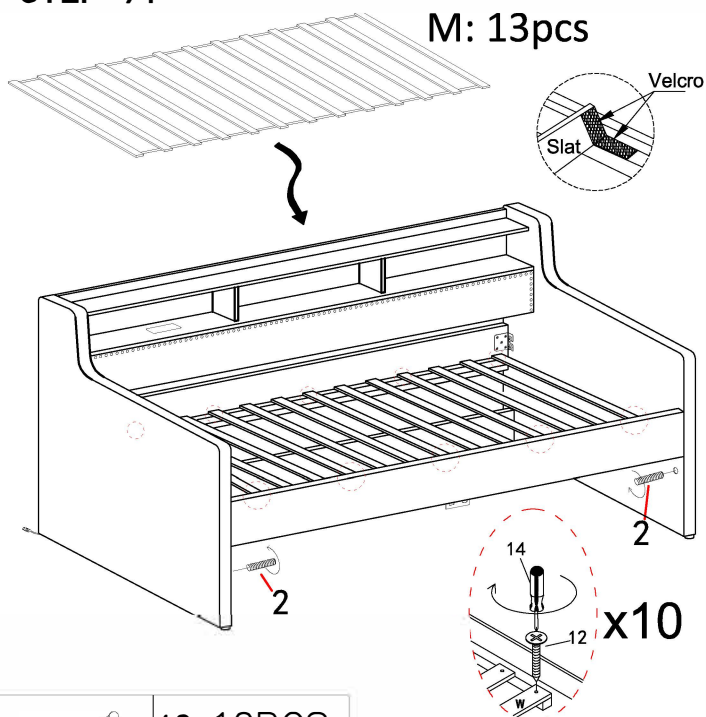

	12: 10PCS
	14: 1PC
	2 : 2PCS
	8 : 1PC
	9 : 1PC

When you assemble this bed, step 9 please make sure all screws are fastened tightly.

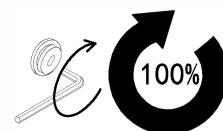

Assembly Steps

STEP 10:

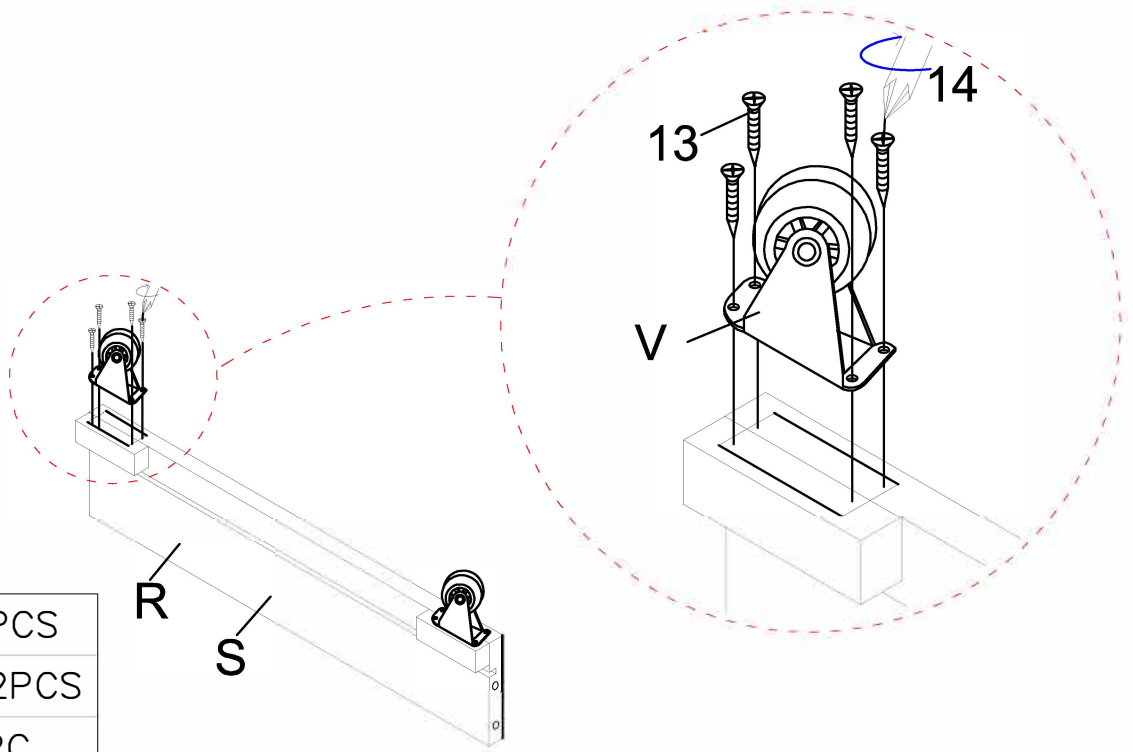

	V: 8PCS
	13: 32PCS
	14: 1PC

STEP 11:

ASSEMBLY TOOLS REQUIRED (NOT INCLUDED)

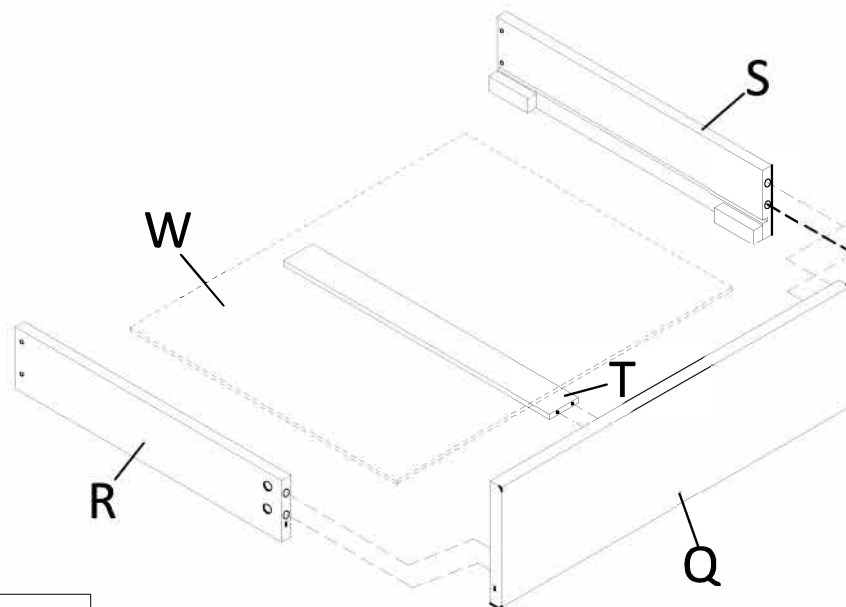
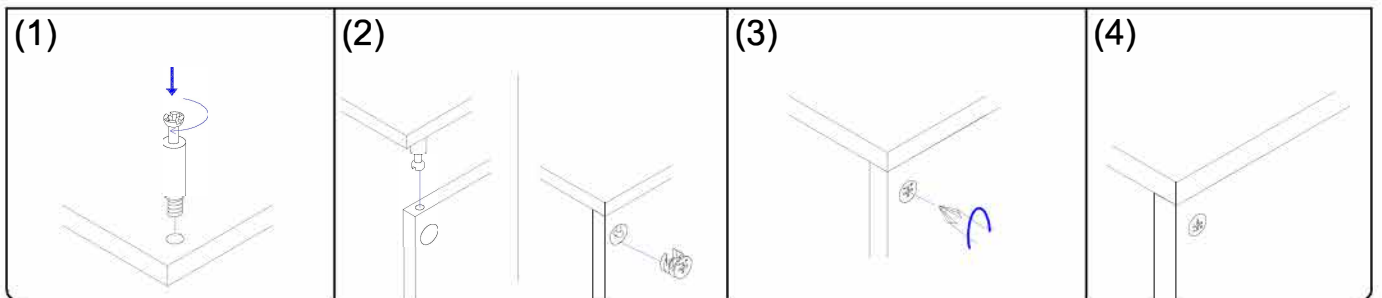
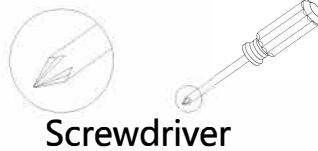

	10: 12PCS
	11: 12PCS

Assembly Steps

STEP 12:

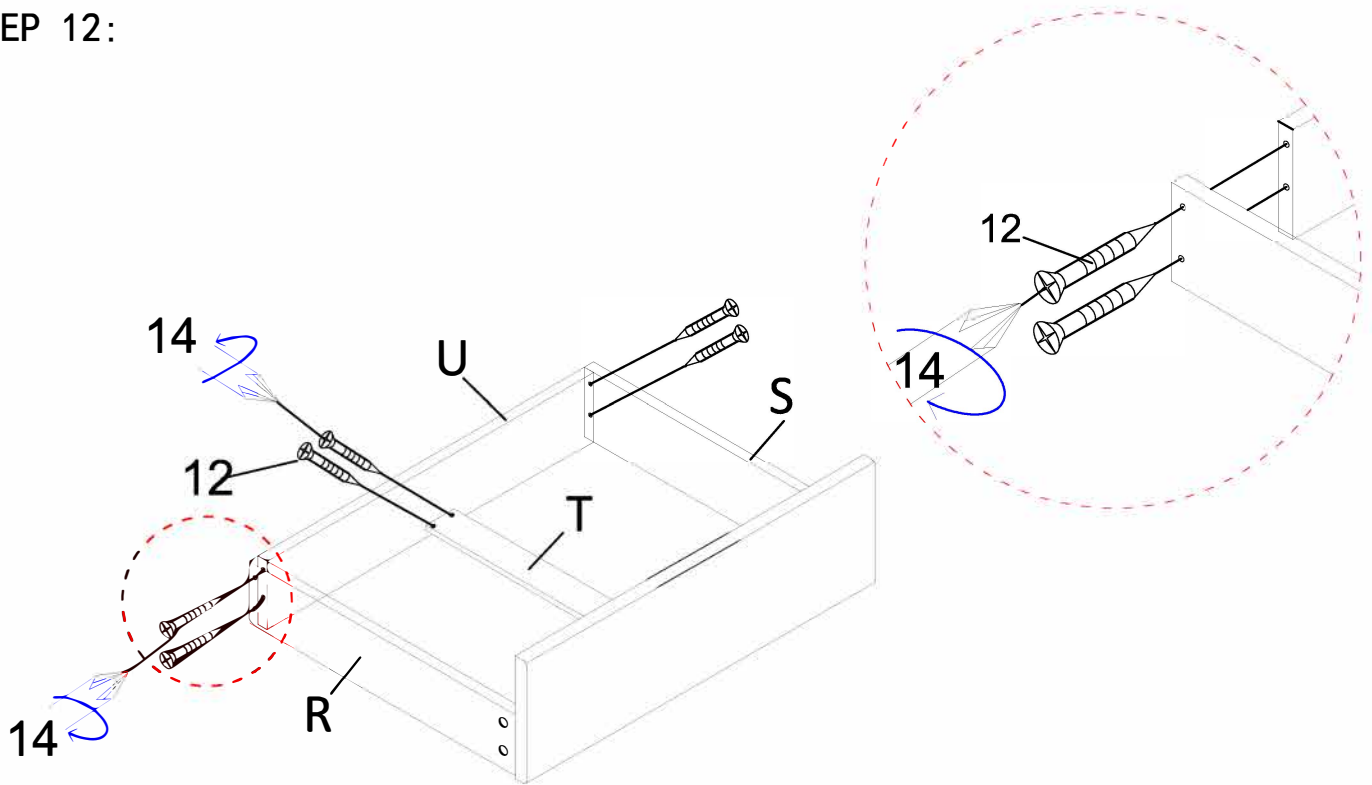

	12: 12PCS
	14: 1PC

STEP 13:

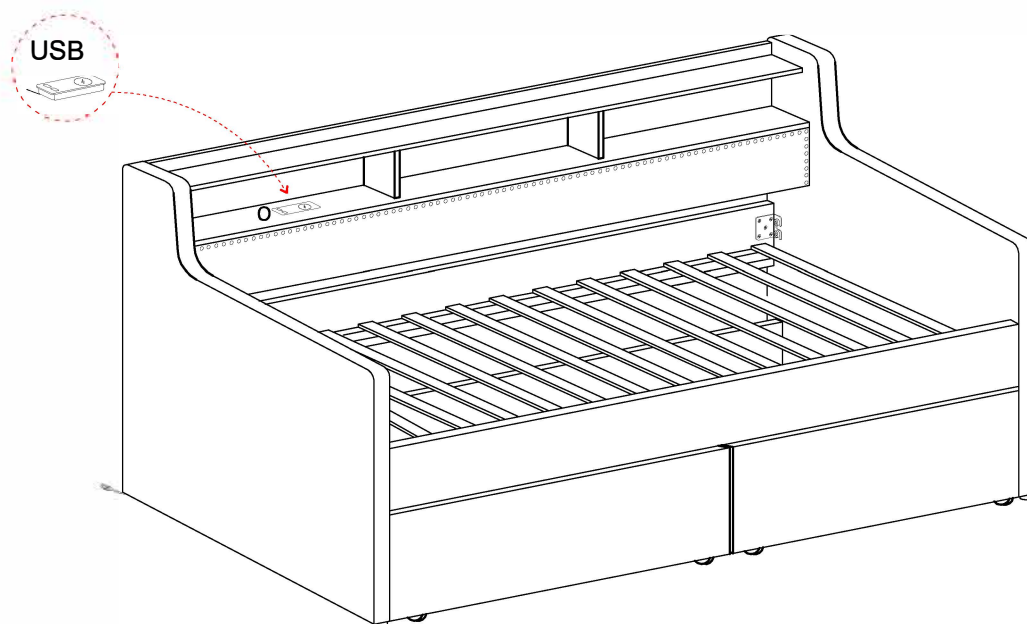

(o)&(p) Please refer to the appendix for details of installation and usage.