

Assembly Instructions

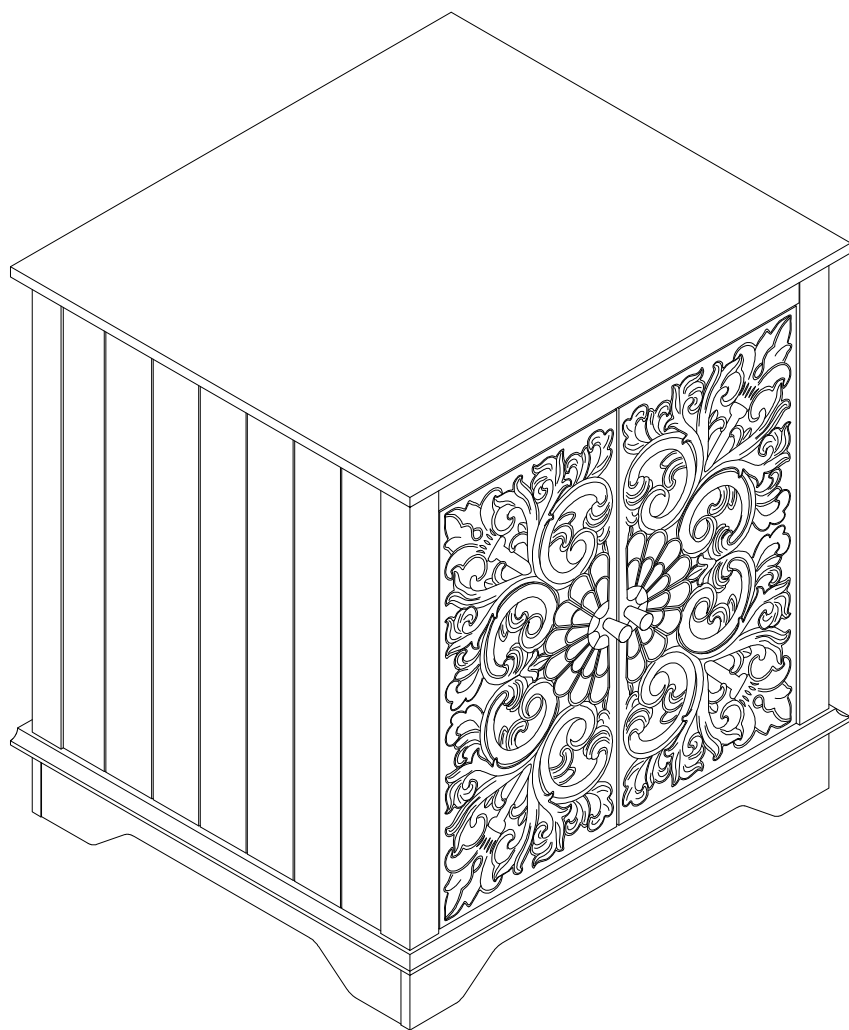

Before Assembly

Tips Before Your Start:

- Remove all wrapping material, including staples & packing straps before you start to assemble.
- DO NOT tighten all screws and bolts until the assembly is completely assembled.
- Keep all hardware parts out of reach of children.

QUICKFIT

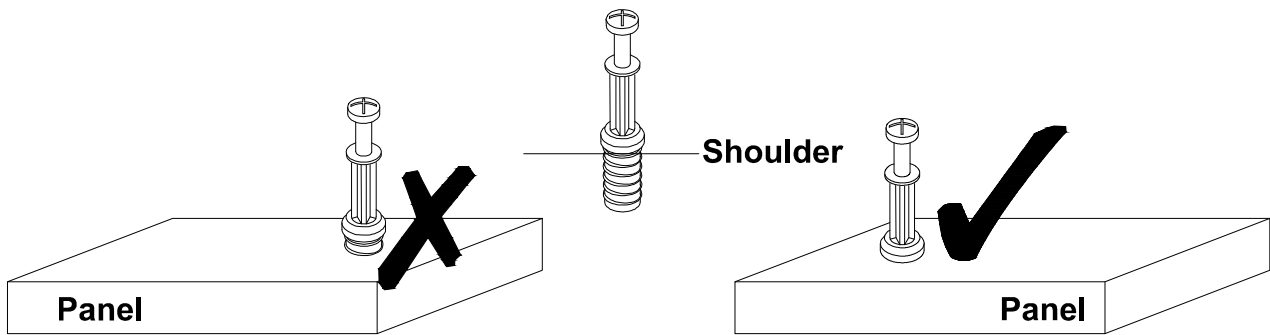

Tighten quickfit until shoulder is flush with panel. Do not overtighten or undertighten.

CAM LOCK

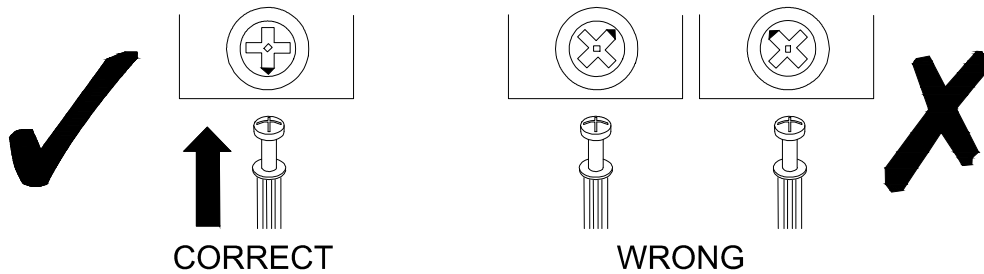

When fitting a cam lock, ensure the starting position is correct before inserting the connecting QUI CKFIT





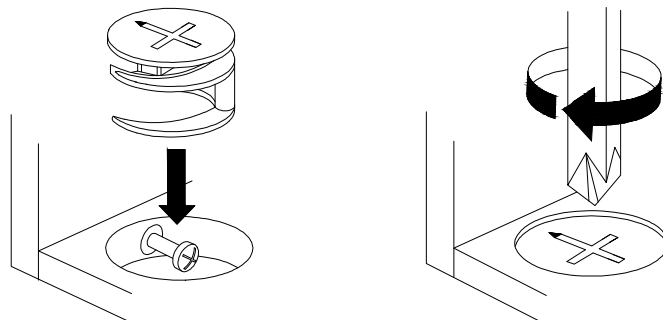

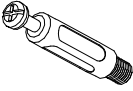

Quickfit head should be in the centre of the cam lock when the two panels are joined.

Cam lock should be inserted before quickfit.

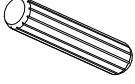
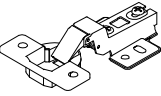

Turn cam lock clockwise to tighten.

Part List

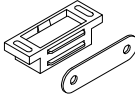
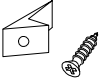
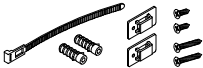
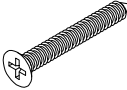
<p>No. A Quantity:36 Pcs Cam Lock Dowel 8*28mm</p> 	<p>No. B Quantity:36 Pcs Cam φ15</p> 	<p>No. C Quantity:36 Pcs Sticker Ø20</p> 	<p>No. D Quantity:29 Pcs Dowel 8*30mm</p> 
<p>No. E Quantity:4 Pcs Hinge</p> 	<p>No. F Quantity:4 Pcs Shelf Support M5*15mm</p> 	<p>No. G Quantity:32 Pcs Screw M3.5*14mm</p> 	<p>No. H Quantity:2 Pcs Handle Ø20*23mm</p> 
<p>No. I Quantity:4 Pcs Foot Pad Ø15</p> 	<p>No. J Quantity:2 Pcs Screw M4*25mm</p> 	<p>No. K Quantity:2 Sets Magnetic Door Catcher</p> 	<p>No. L Quantity:4 Sets Plastic Wedge</p> 
<p>No. M Quantity:1 Sets Anti-falling Parts</p> 	<p>No. N Quantity:8 Pcs Screw M4*35mm</p> 		

Product structure

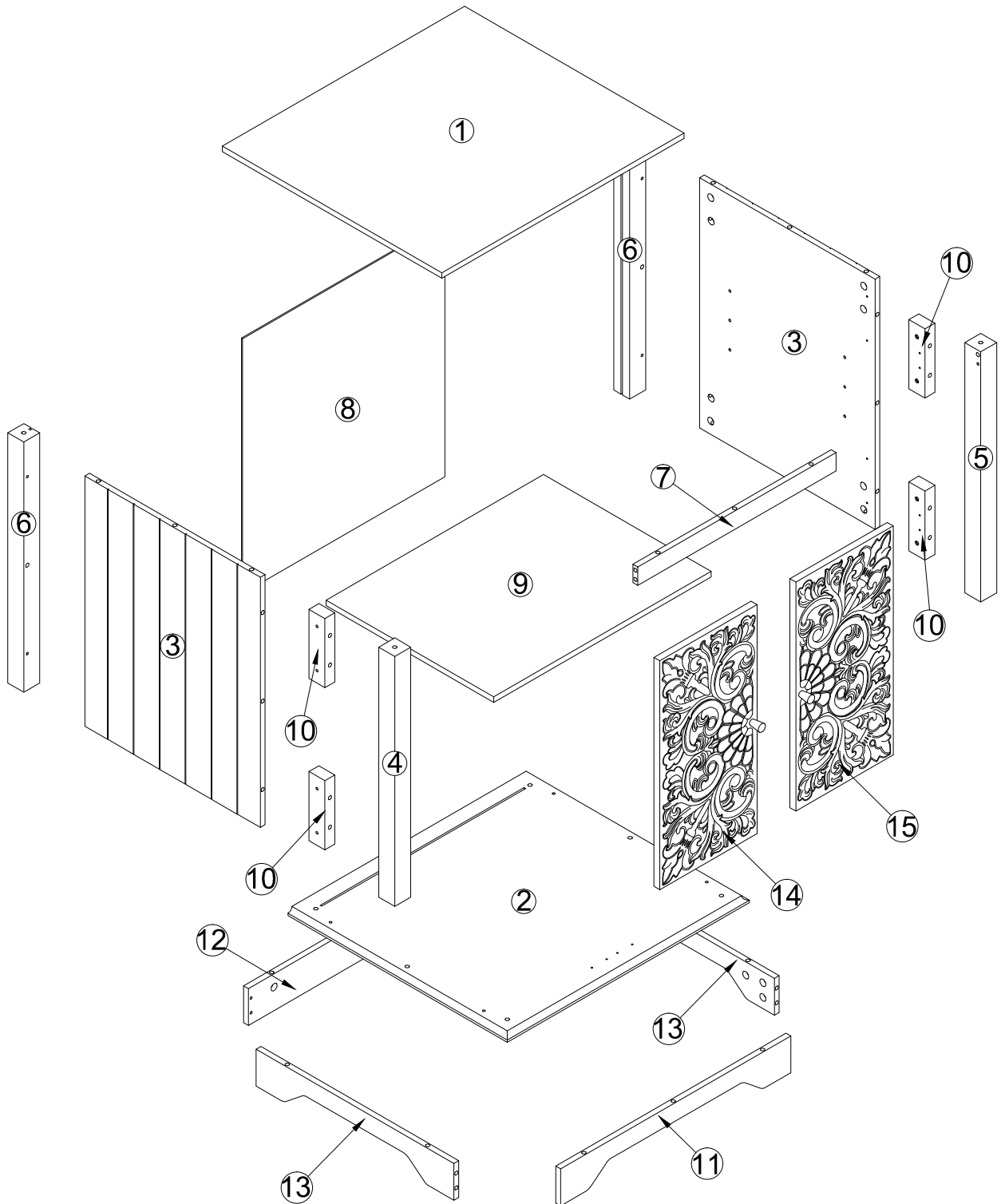

STEP 1

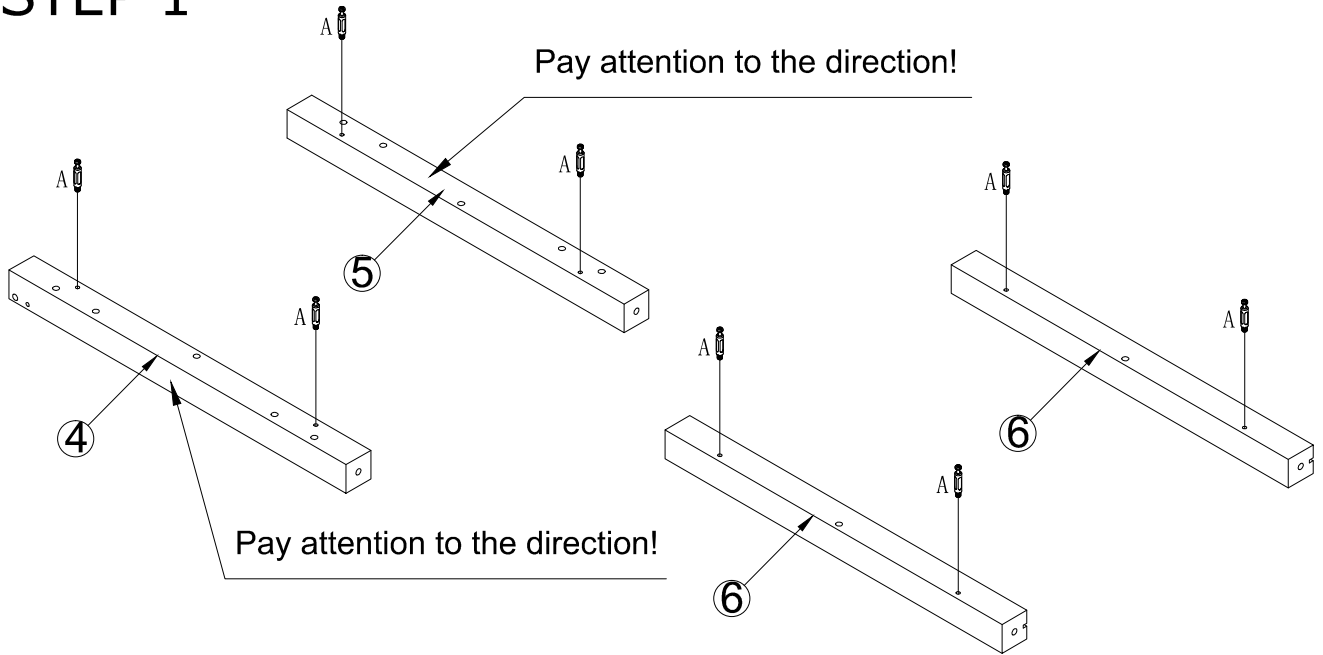

No. A
Quantity: 8 Pcs
8*28 mm



STEP 2

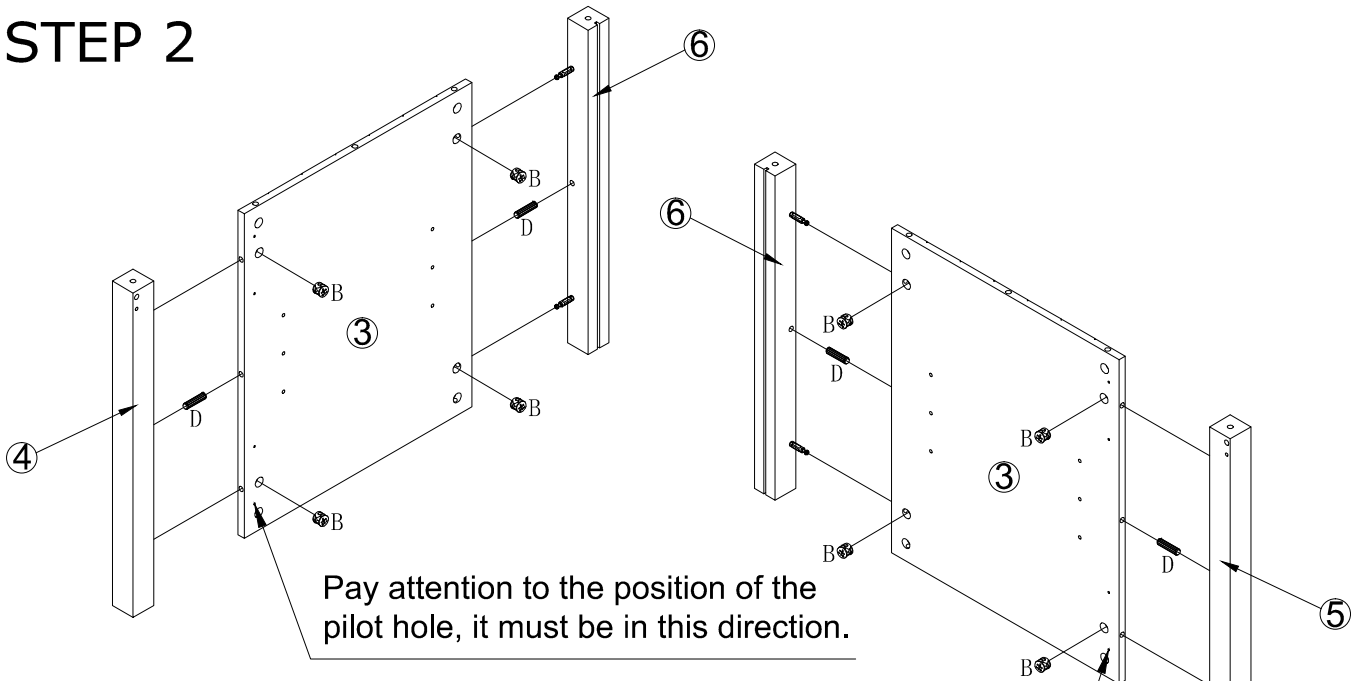

No. B
Quantity: 8 Pcs
Ø15



No. D
Quantity: 4 Pcs
8*30mm

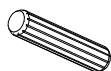

STEP 3

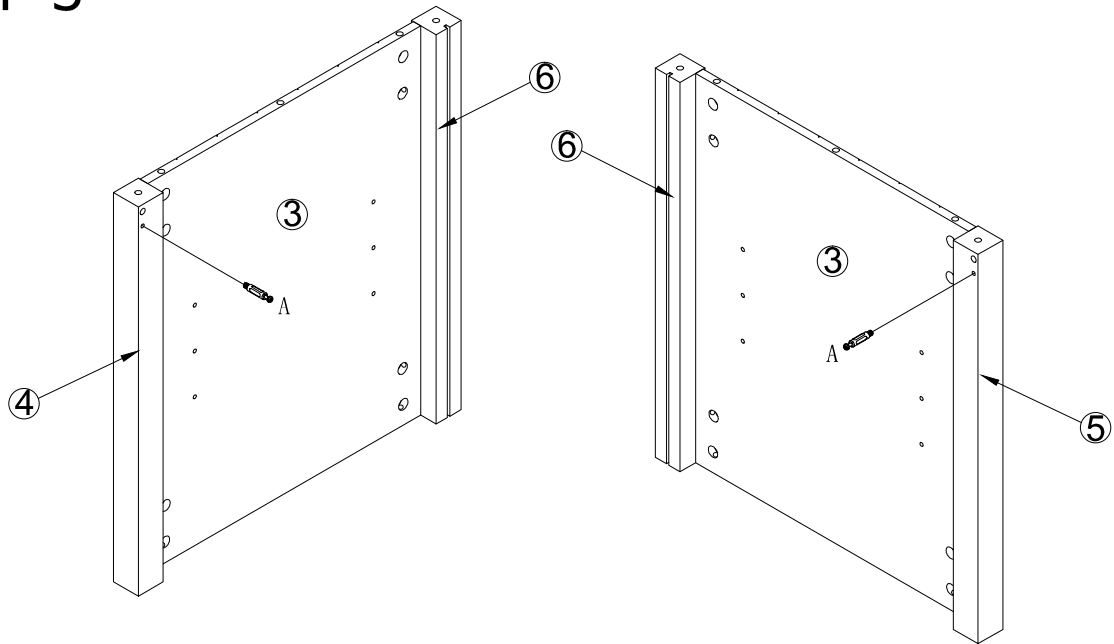

No. A
Quantity: 2 Pcs
8*28 mm



STEP 4

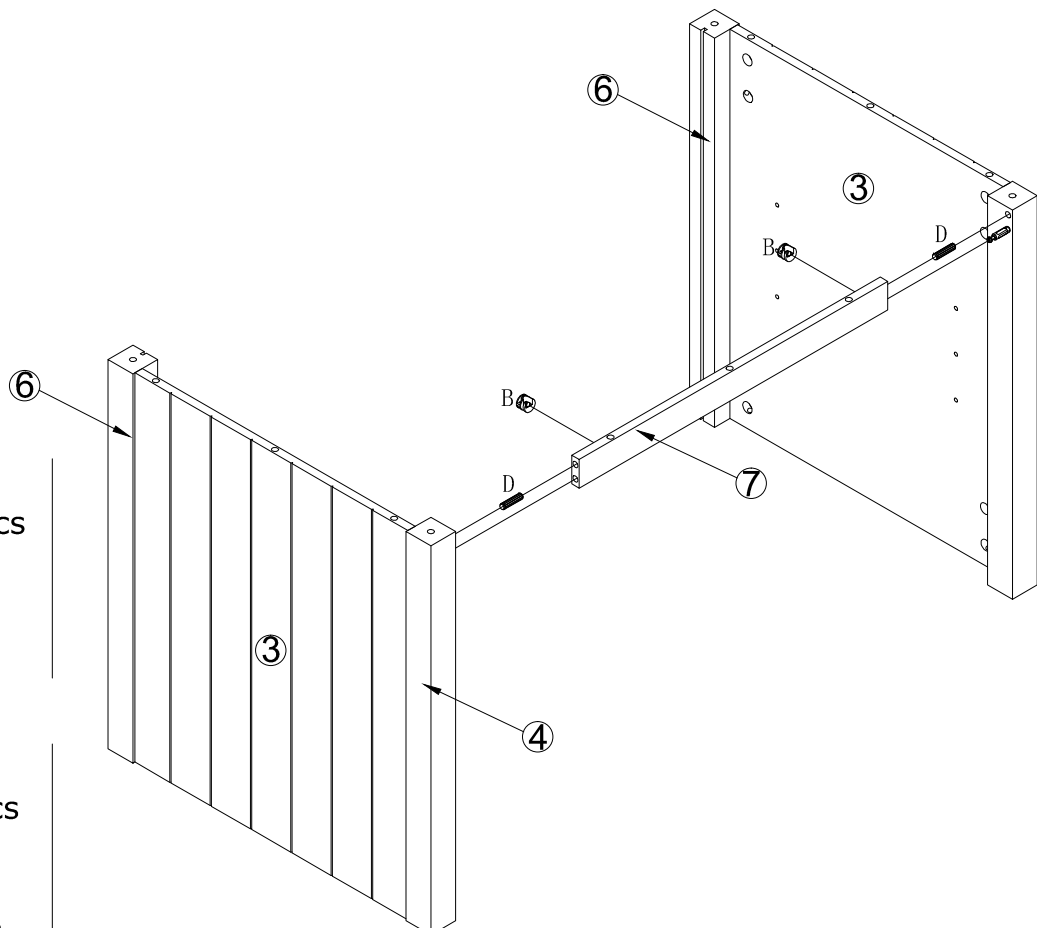

No. B
Quantity: 2 Pcs
Ø15



No. D
Quantity: 2 Pcs
8*30mm

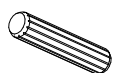

STEP 5

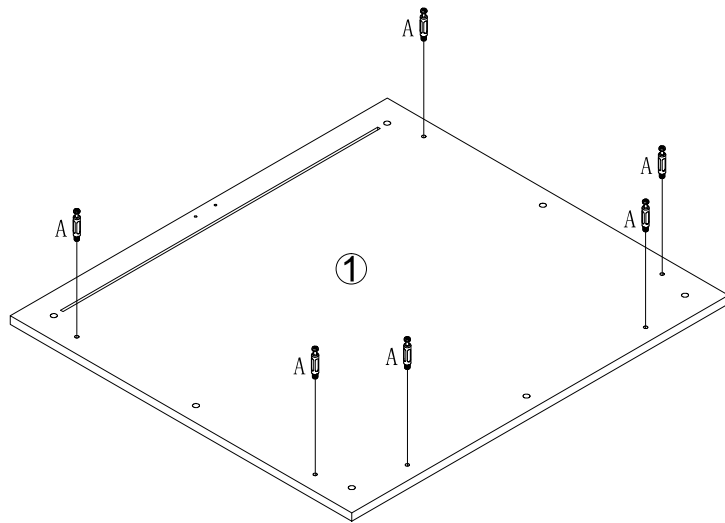

No. A
Quantity: 6 Pcs
8*28 mm



STEP 6

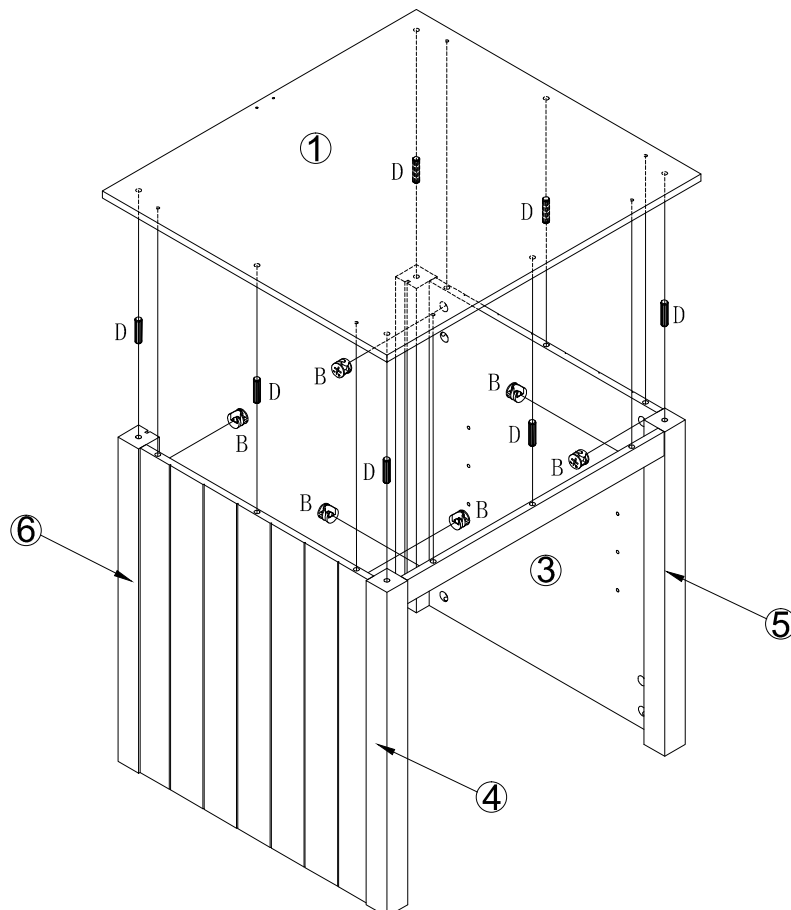

No. B
Quantity: 6 Pcs
Ø15



No. D
Quantity: 7 Pcs
8*30mm

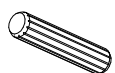

STEP 7

Note: This block has holes on both sides, please pay attention to the difference.

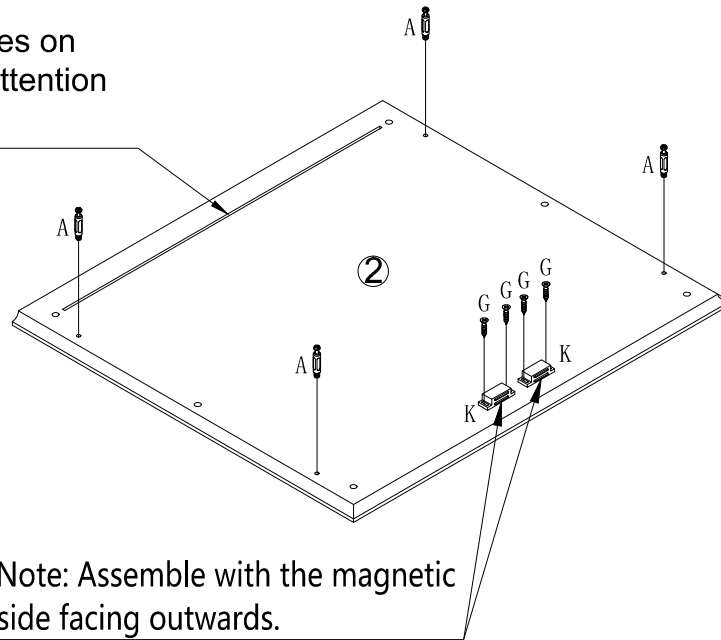

No. A
Quantity: 4 Pcs
8*28 mm



No. G
Quantity: 4 Pcs
M3.5*14mm



No. K
Quantity: 2 Pcs

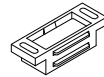

STEP 8

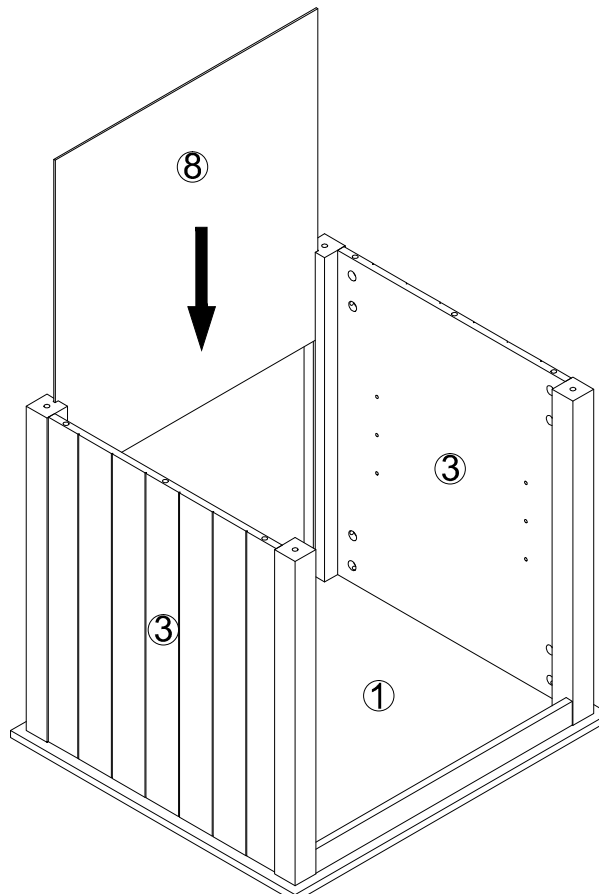

STEP 9

No. B
Quantity: 4 Pcs
Ø15



No. D
Quantity: 6 Pcs
8*30mm

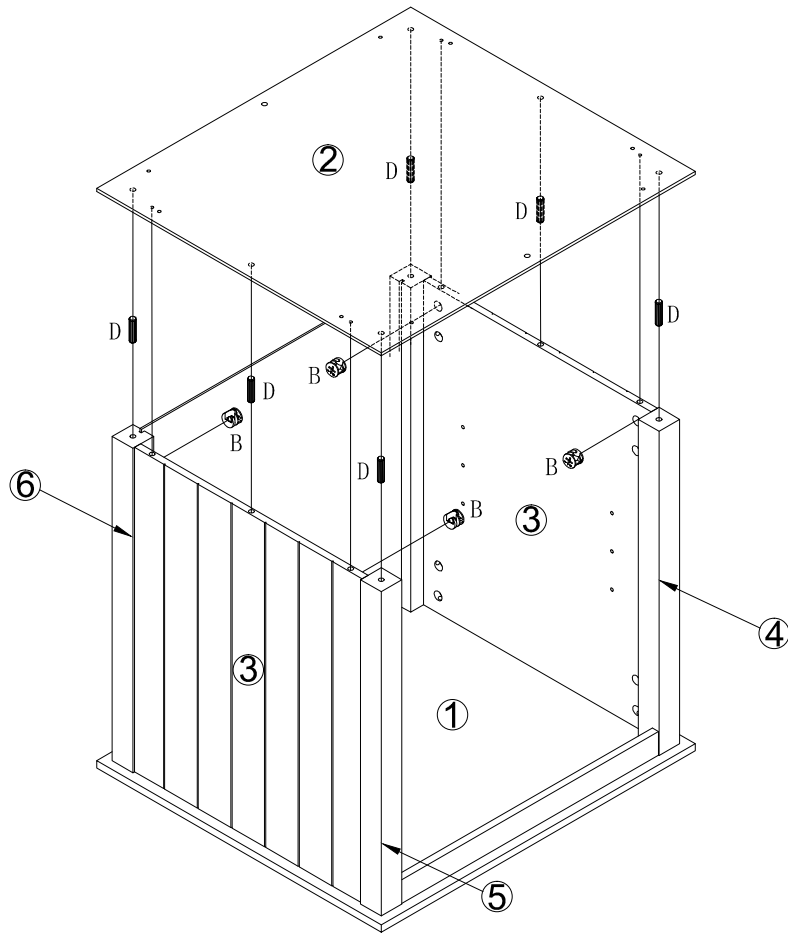
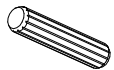

STEP 10

No. A
Quantity: 8 Pcs
8*28 mm

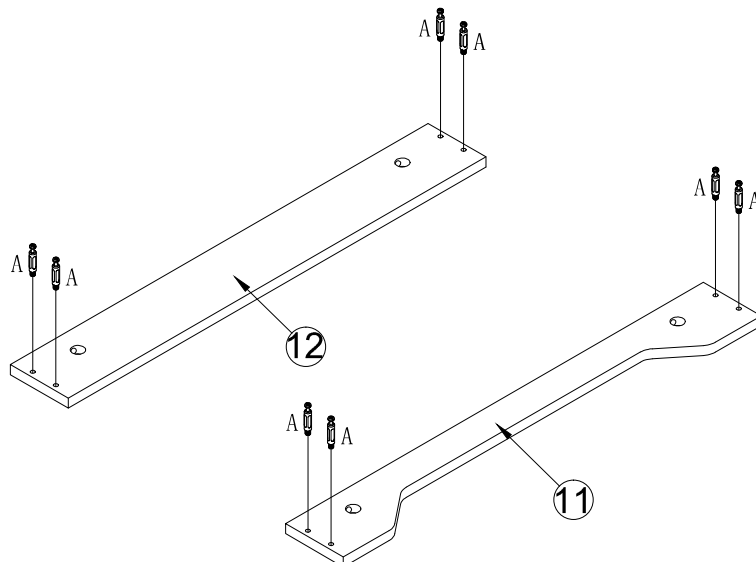

STEP 11

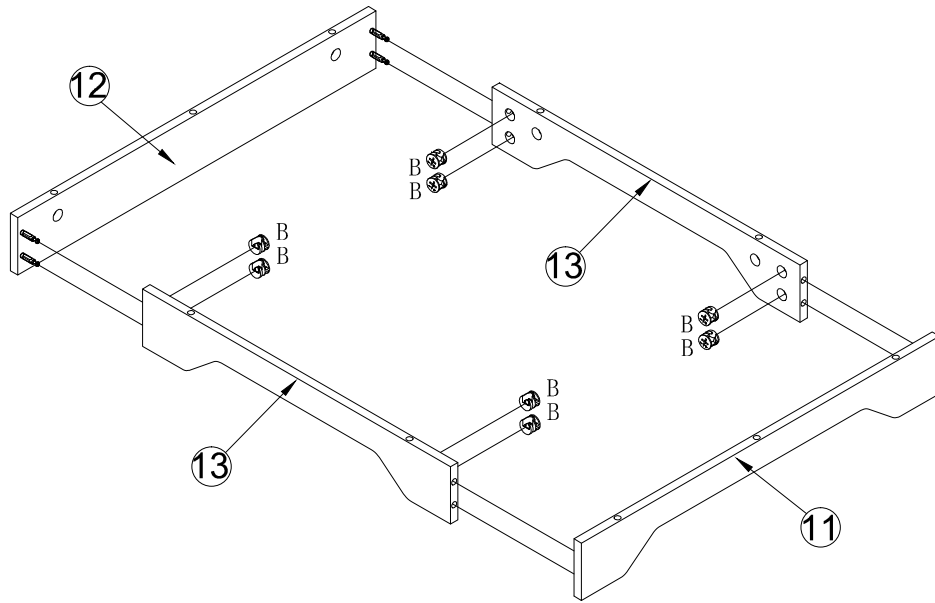

No. B
Quantity: 8 Pcs
Ø15



STEP 12

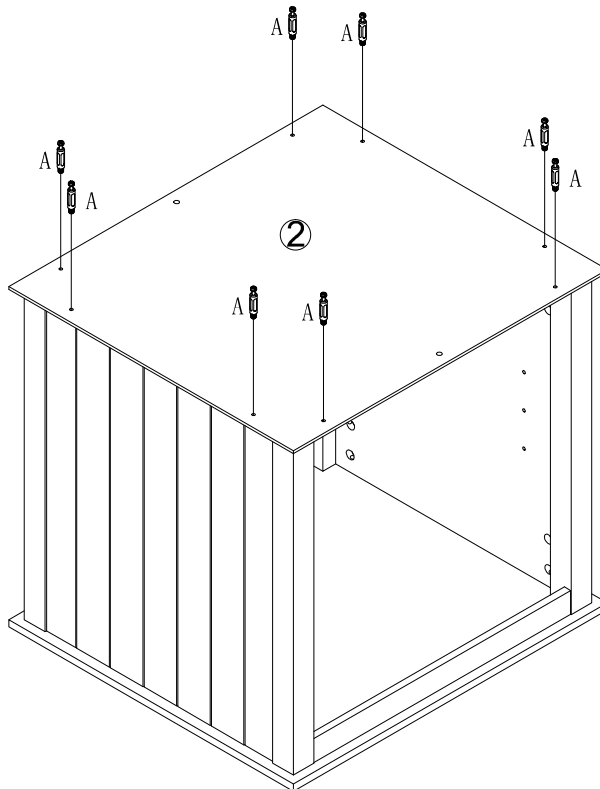

No. A
Quantity: 8 Pcs
8*28 mm



STEP 13

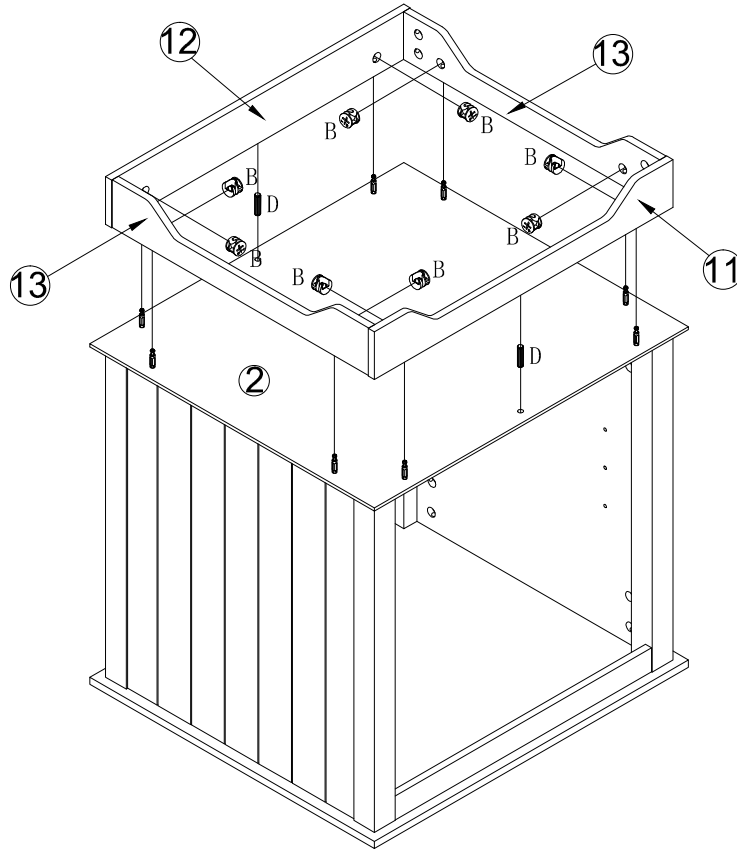

No. B
Quantity: 8 Pcs
Ø15



No. D
Quantity: 2 Pcs
8*30mm

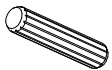

STEP 14

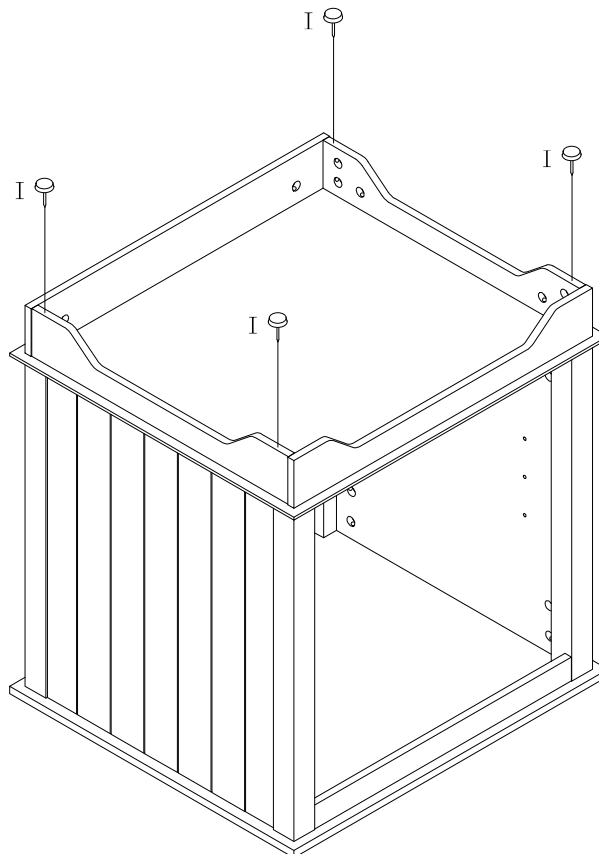

No. I
Quantity: 4 Pcs
Ø15



STEP 15

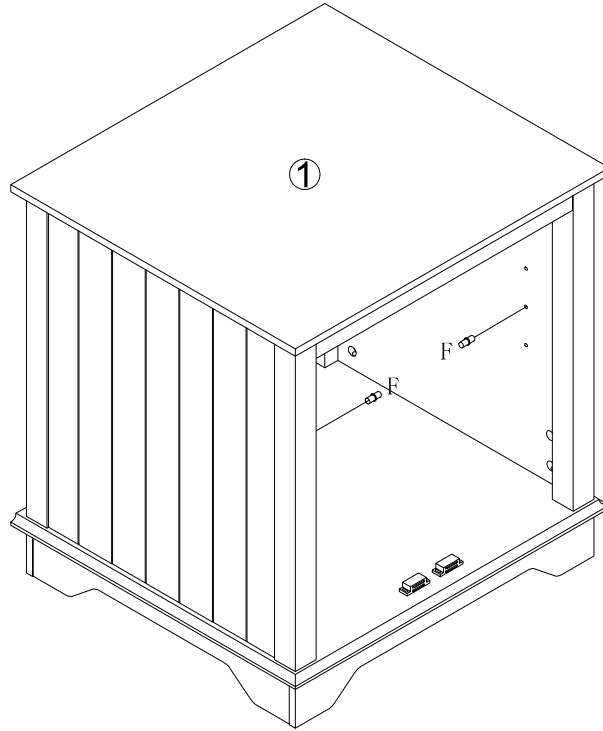

No. F
Quantity: 4 Pcs
M5*15mm



STEP 16

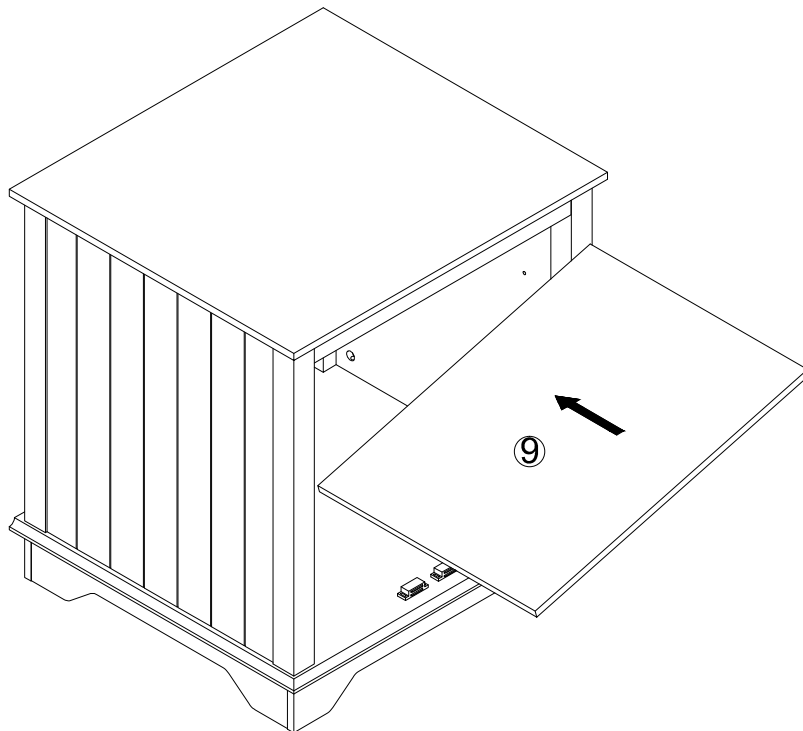

STEP 17

Please note the guide hole above number 10, the direction must be outward!

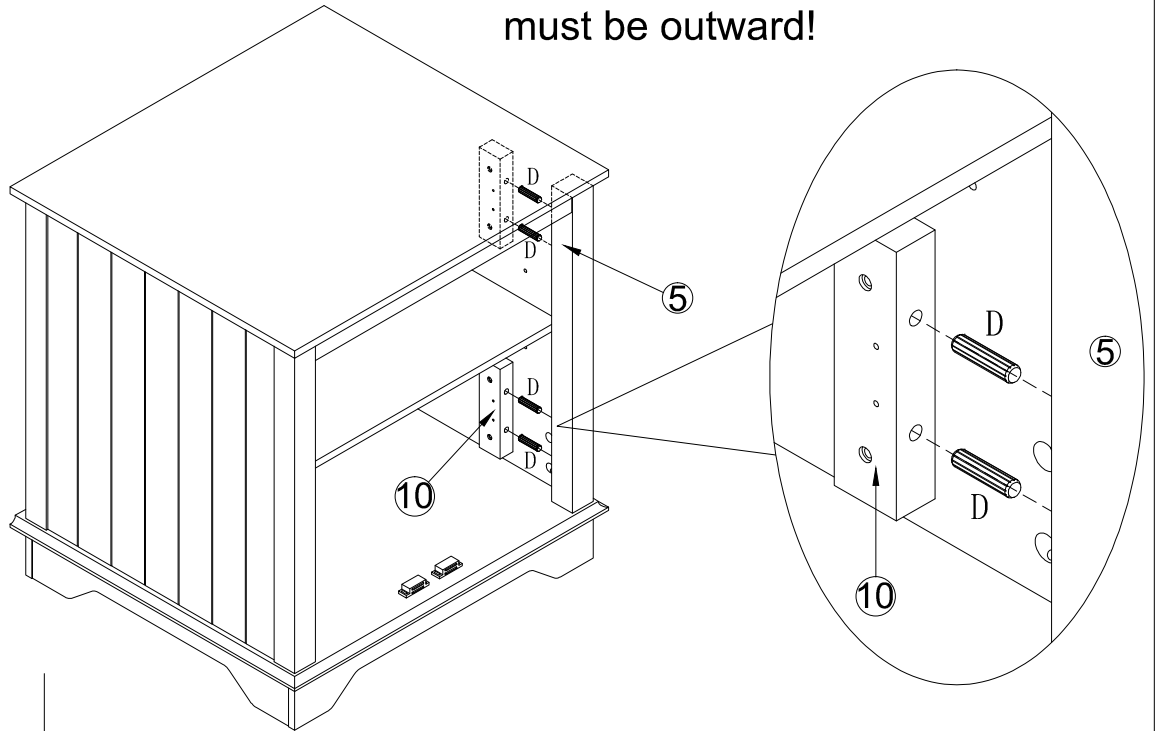

No. D
Quantity: 4 Pcs
8*30mm

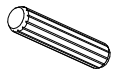

STEP 18

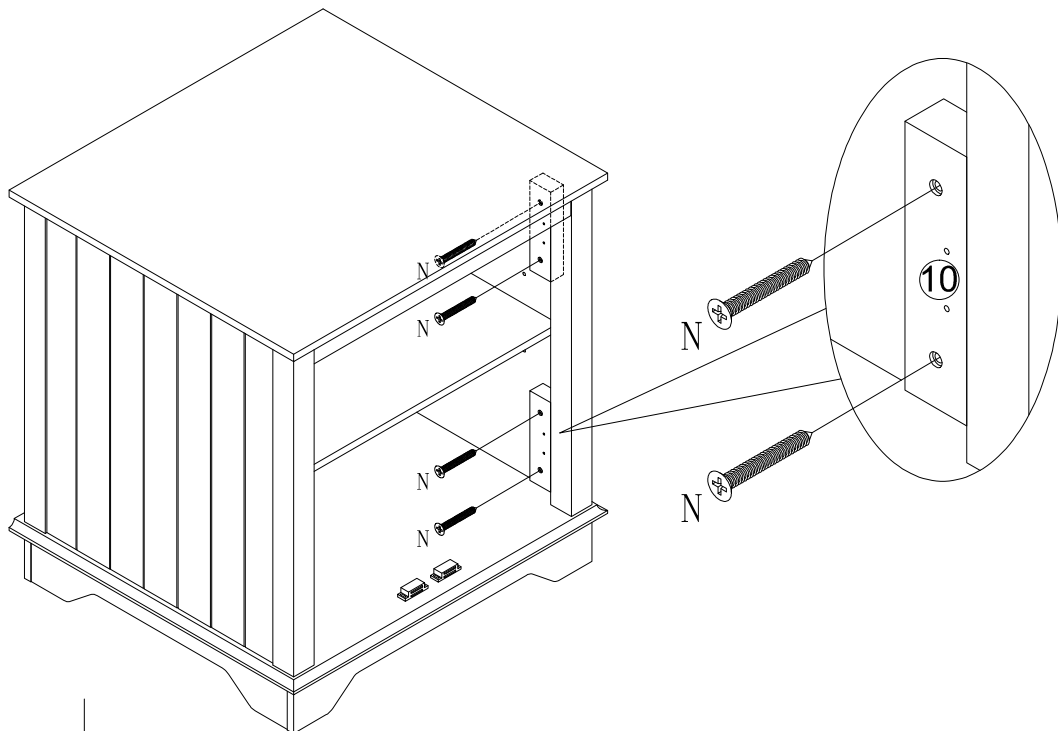

No. N
Quantity: 4 Pcs
M4*35mm

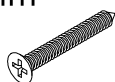

STEP 19

Please note the guide hole above number 10, the direction must be outward!

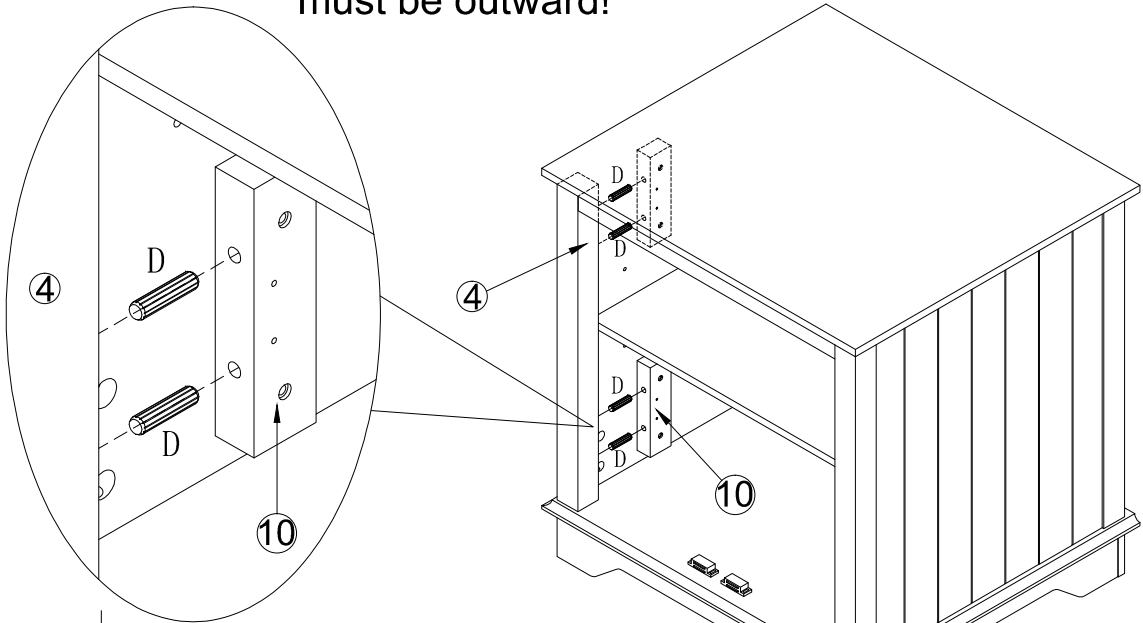

No. D
Quantity: 4 Pcs
8*30mm

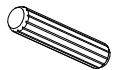

STEP 20

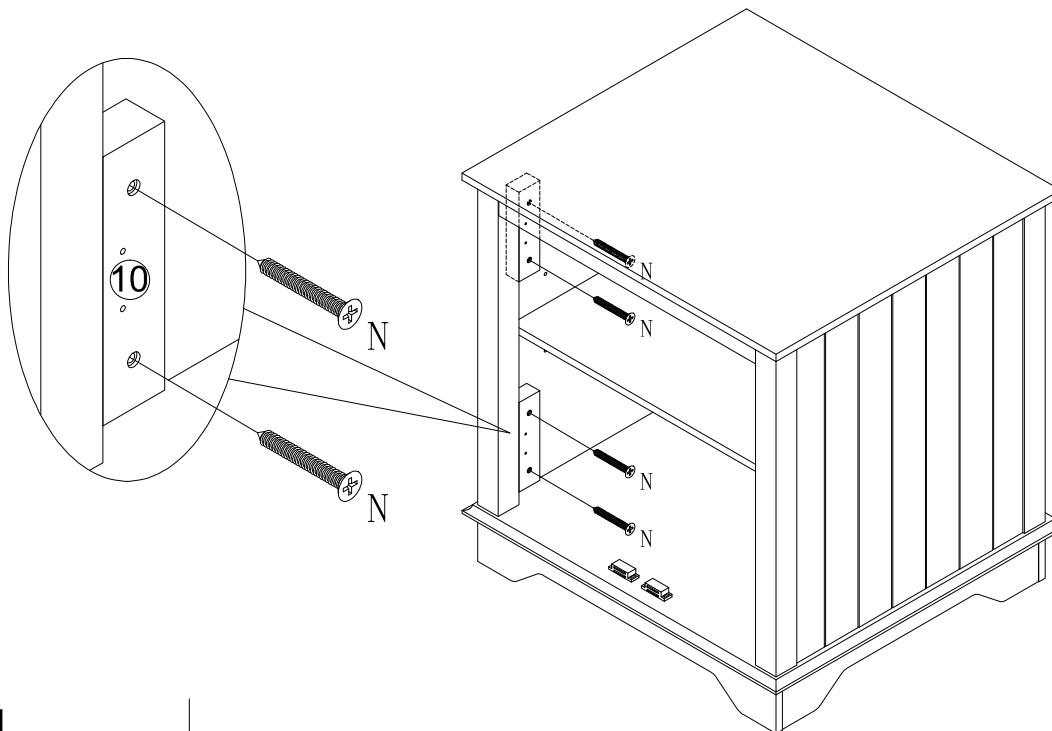

No. N
Quantity: 4 Pcs
M4*35mm

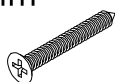

STEP 21

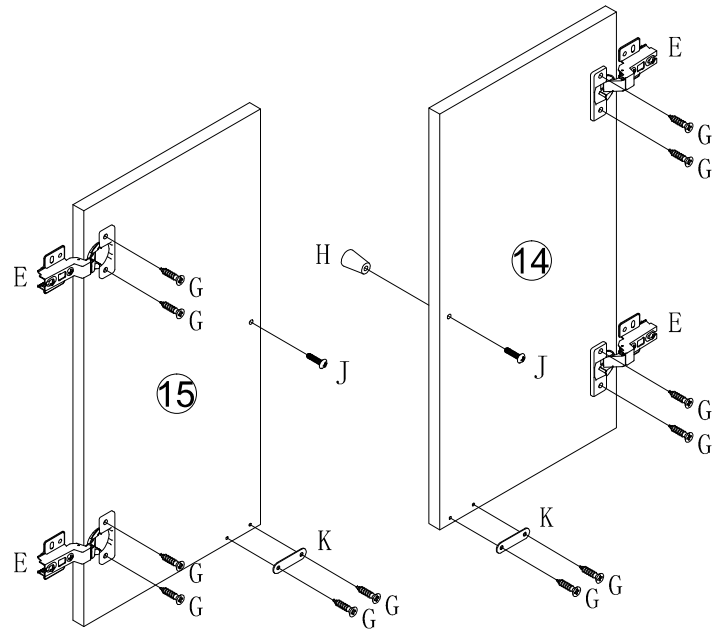

No. E
Quantity: 4 Pcs

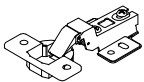

No. G
Quantity: 12 Pcs
M3.5*14mm



No. H
Quantity: 2 Pcs
Ø20*23mm



No. J
Quantity: 2 Pcs
M4*25mm



No. K
Quantity: 2 Pcs



STEP 22

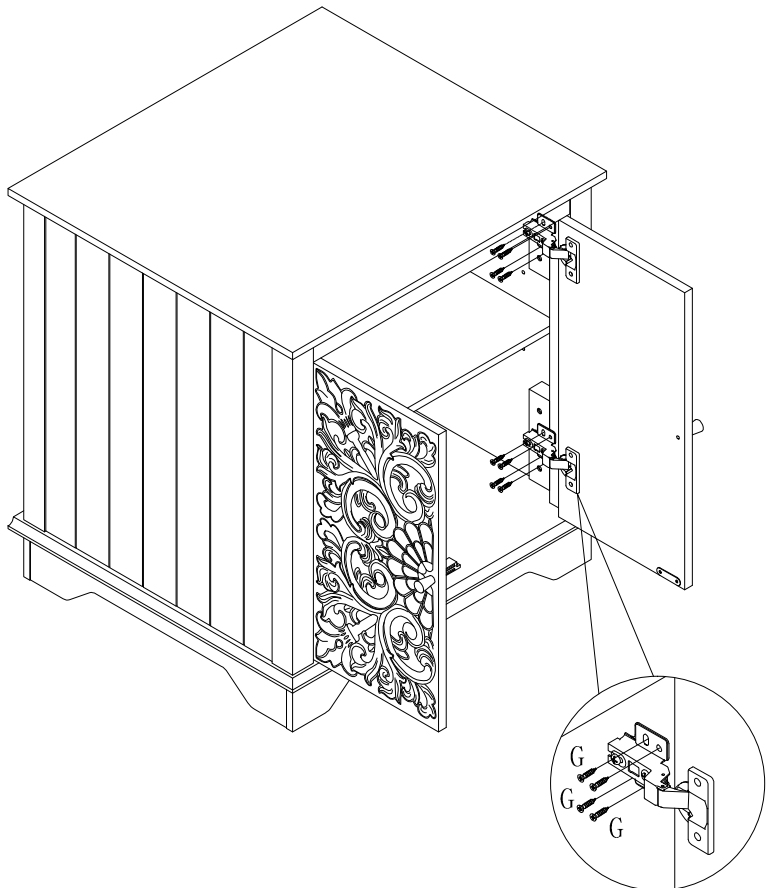
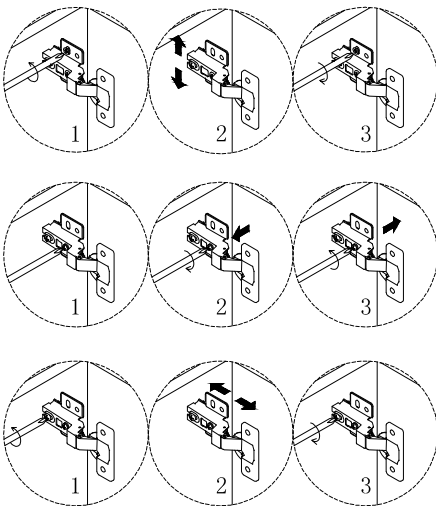

No. G
Quantity: 16 Pcs
M3.5*14mm



STEP 23

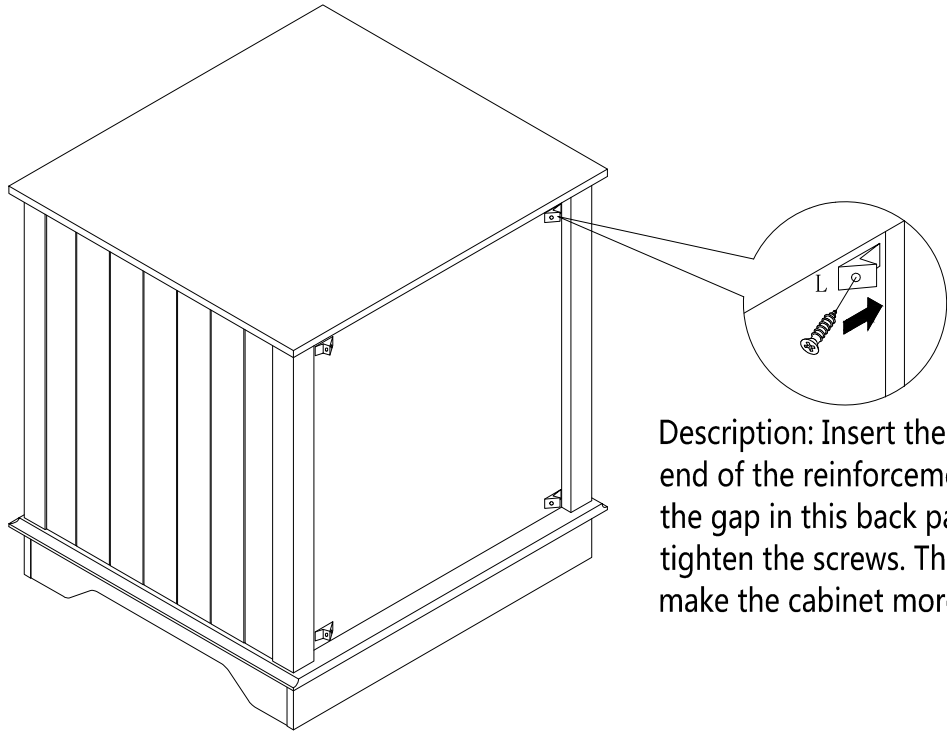

No. L
Quantity: 4 Sets

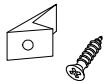

STEP 24

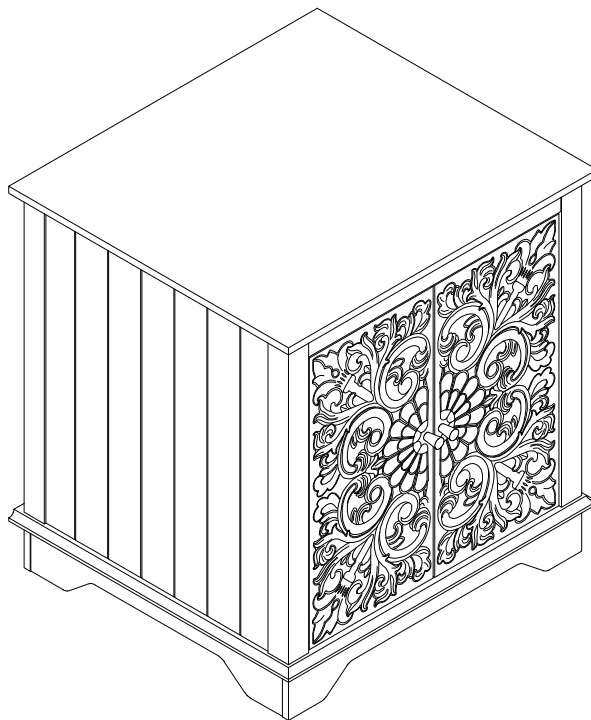

STEP 25

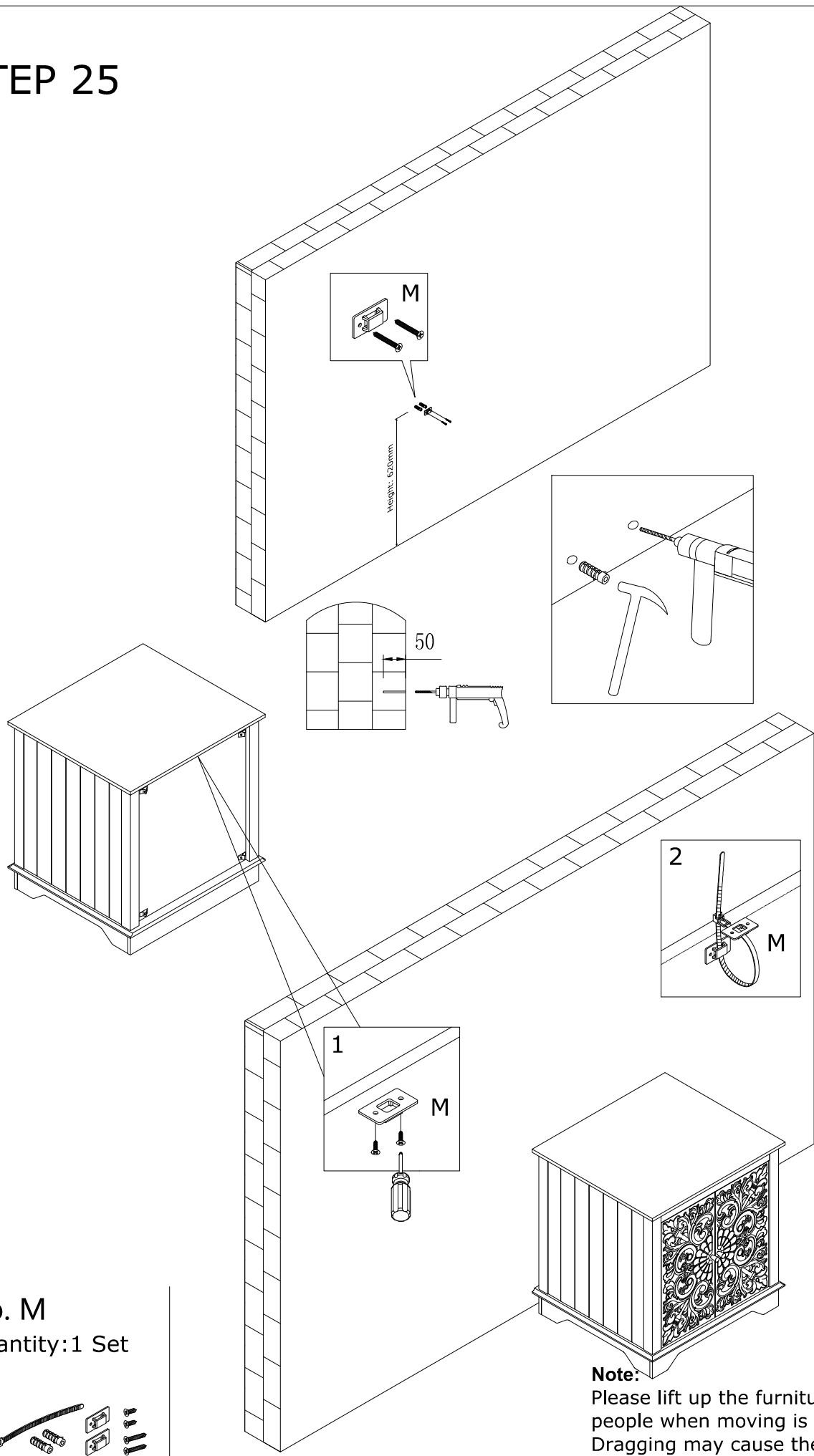

No. M
Quantity: 1 Set

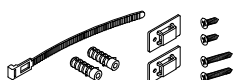

Note:
Please lift up the furniture by two people when moving is needed.
Dragging may cause the legs failure.