

Para Limpeza de seu Móvel: Use uma Flanela seca ou umedecida / Não use produto Químico que pode danificar seu móvel.

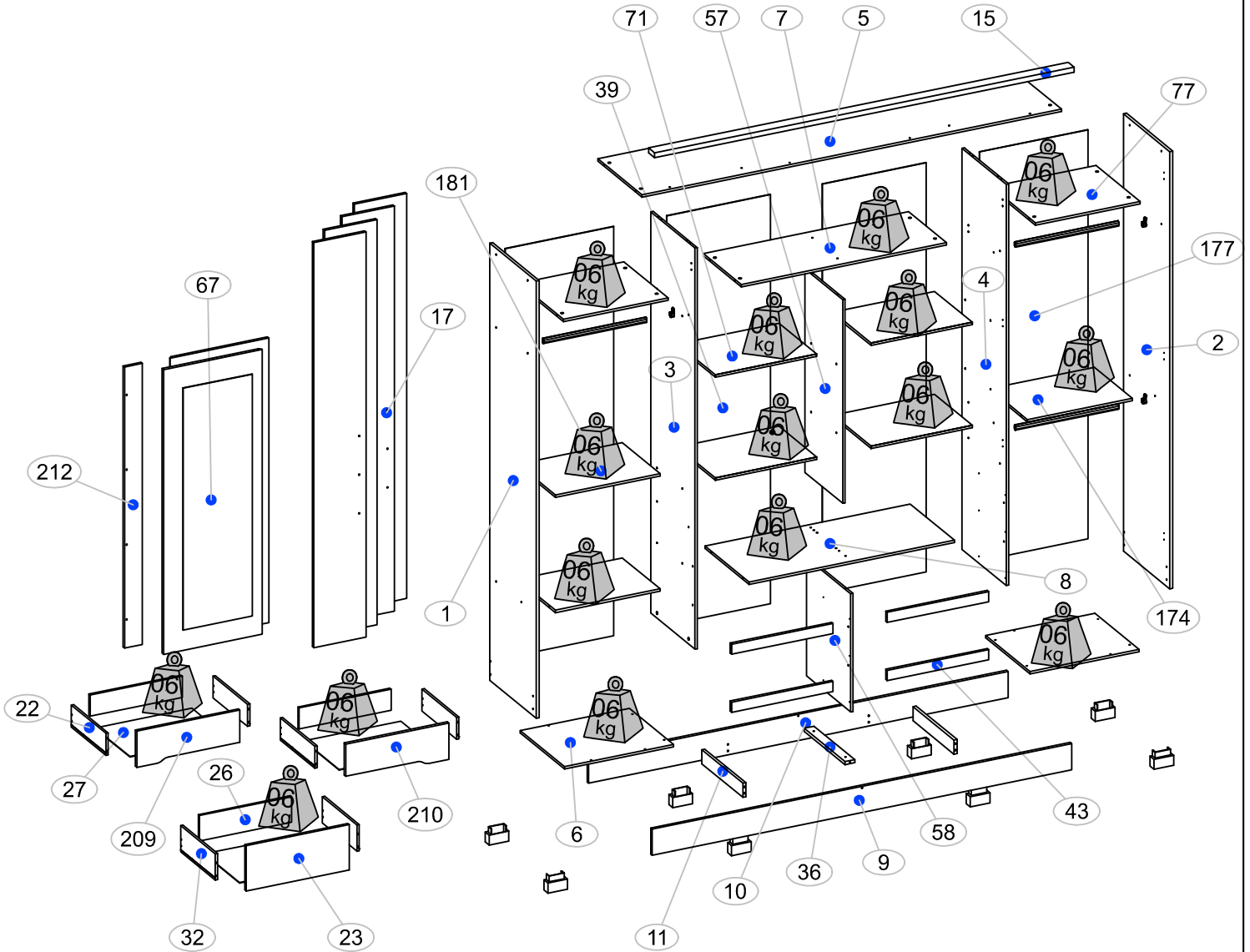







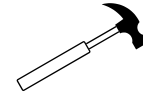
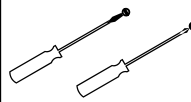
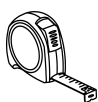

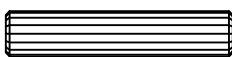
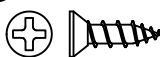
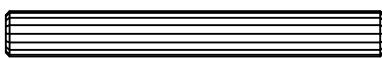
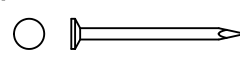
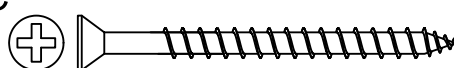
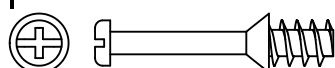
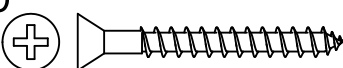
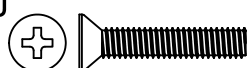
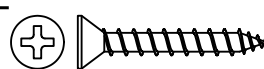
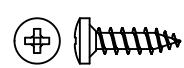









For Cleanness of its Furniture: It uses a dry or umedecida Flannel / It does not use Chemical product that can damage its furniture.  
Limpieza del mobiliario: Utilice una flanela seca o húmeda / No use productos químicos que pueden dañar el mobiliario



\*Ferramentas necessárias para montagem, Não acompanha o produto.

  
Para montar esse produto são necessários dois montadores



<b>A</b>  CAVILHA 6X30 38		<b>G</b>  PARAFUSO 3,5X12 CHATO 108					
<b>B</b>  CAVILHA 6X50 2		<b>H</b>  PREGO 10X10 171					
<b>C</b>  PARAFUSO 4,0X50 CHATO 38		<b>I</b>  PINO DE GIROFIX 2					
<b>D</b>  PARAFUSO 4,0X35 CHATO 54		<b>J</b>  PARAFUSO M 4-70X22 CHATO 4					
<b>E</b>  PARAFUSO 3,5X25 CHATO 16							
<b>F</b>  PARAFUSO 4,0X12 PANELA 124							
<b>K</b>  PORCA 4MM 4	<b>L</b>  FIXADOR RETO 41	<b>M</b>  CASTANHA DE GIROFIX 2	<b>N</b>  CALÇO 12mm 6	<b>O</b>  CALÇO 7mm 12	<b>P</b>  DOBRADIÇA 18	<b>Q</b>  CORREDIÇA TELESCÓPICA 6	<b>R</b>  SUPORTE PRAT. 24
<b>S</b>  BASTÃO 522mm 3	<b>T</b>  SUPORTE CABIDEIRO 6	<b>U</b>  SUPORTE PRAT. 20	<b>V</b>  SAPATA U 8	<b>W</b>  KIT PÉ MOVAL 8	<b>X</b>  GIZ DE CORREÇÃO 2	<b>Y</b>  BUCHÇA CILÍNDRICA 38	<b>Z</b>  PUX. MDF 480mm 4
<b>AA</b>  COLA 12G 3	<b>AB</b>  PERFIL I 394mm 1	 ETIQUETA LIT					

## 01

Atenção montador, antes de iniciar a montagem desse produto, favor verificar com o cliente se ele prefere que o produto seja montado com pés ou com sapatas.

Produto montado com pé  
altura 2220mm

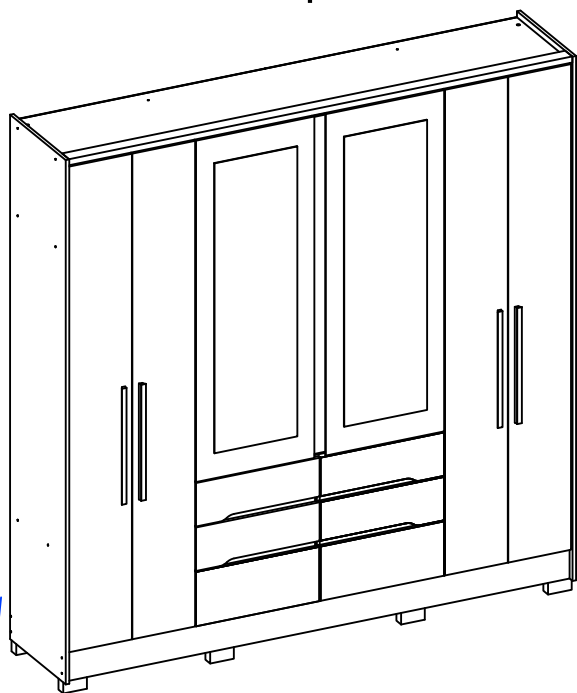

Produto montado com sapata.  
altura 2175mm

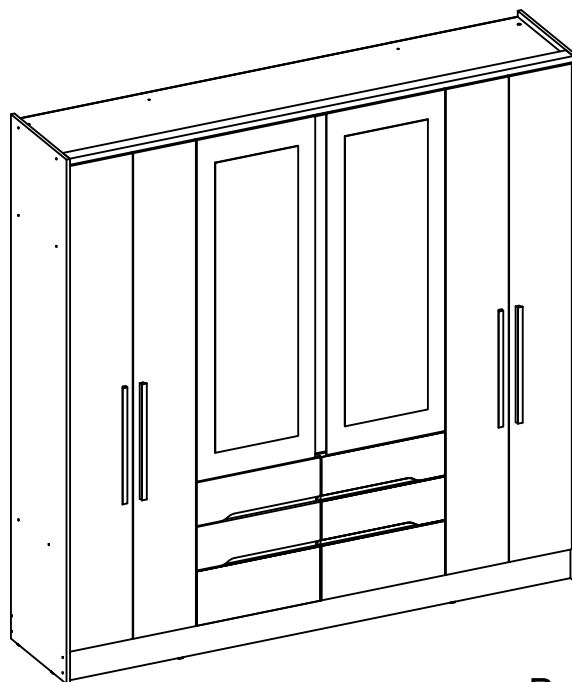

02

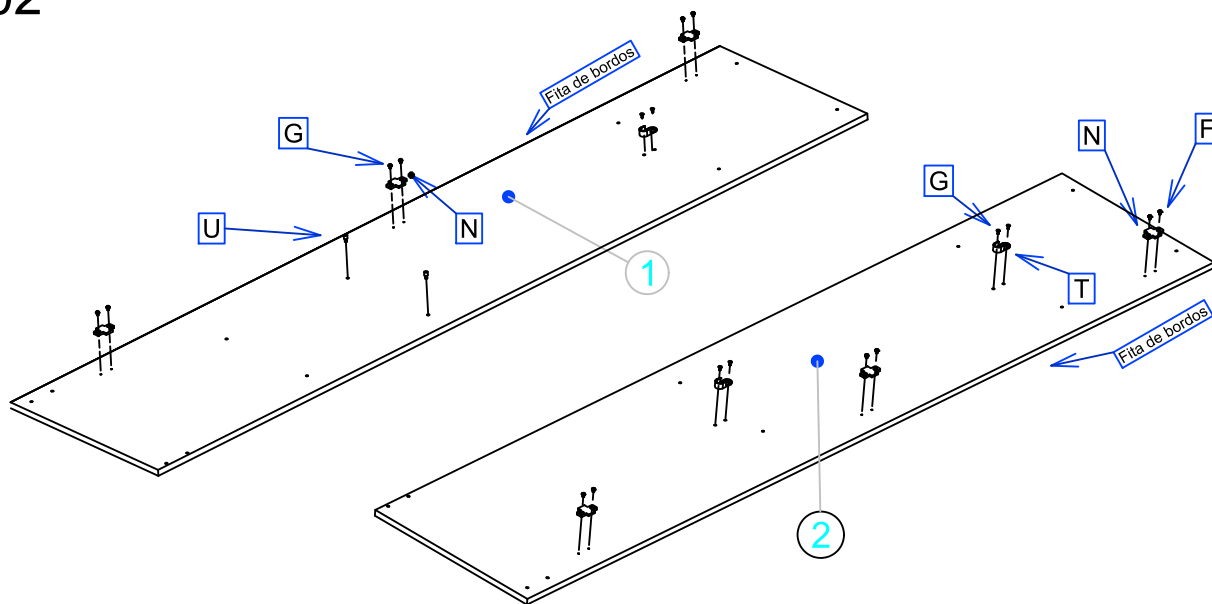

N		6
F		12
G		6
U		2
T		3

03

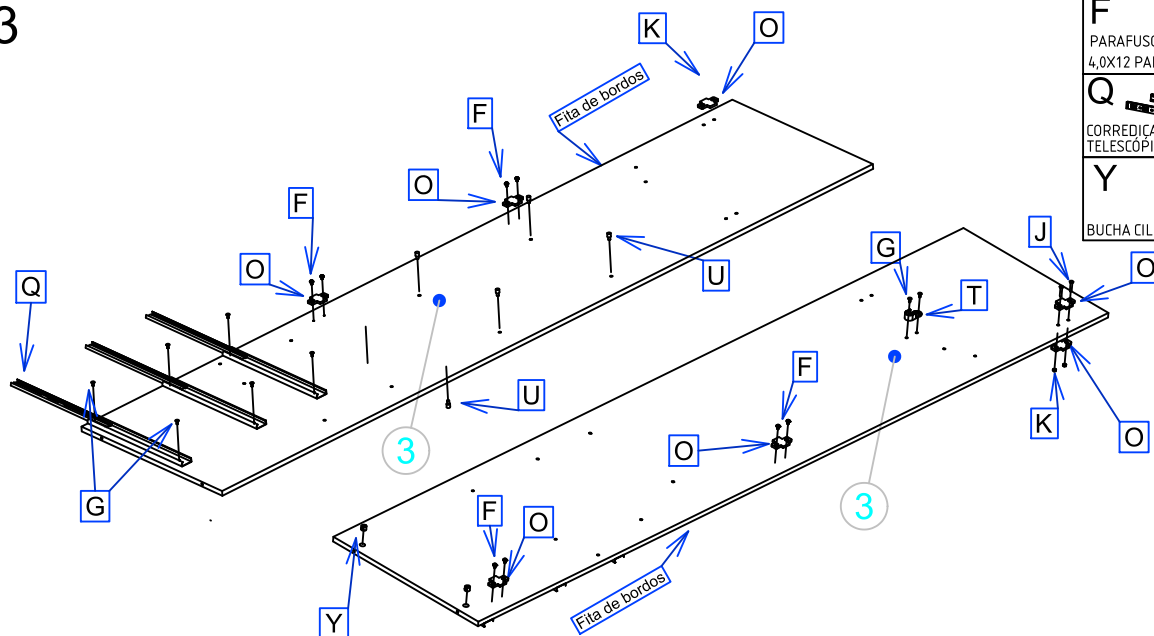

F		8
Q		3
Y		2
T		1
U		6
G		8
O		6
J		2
K		2

04

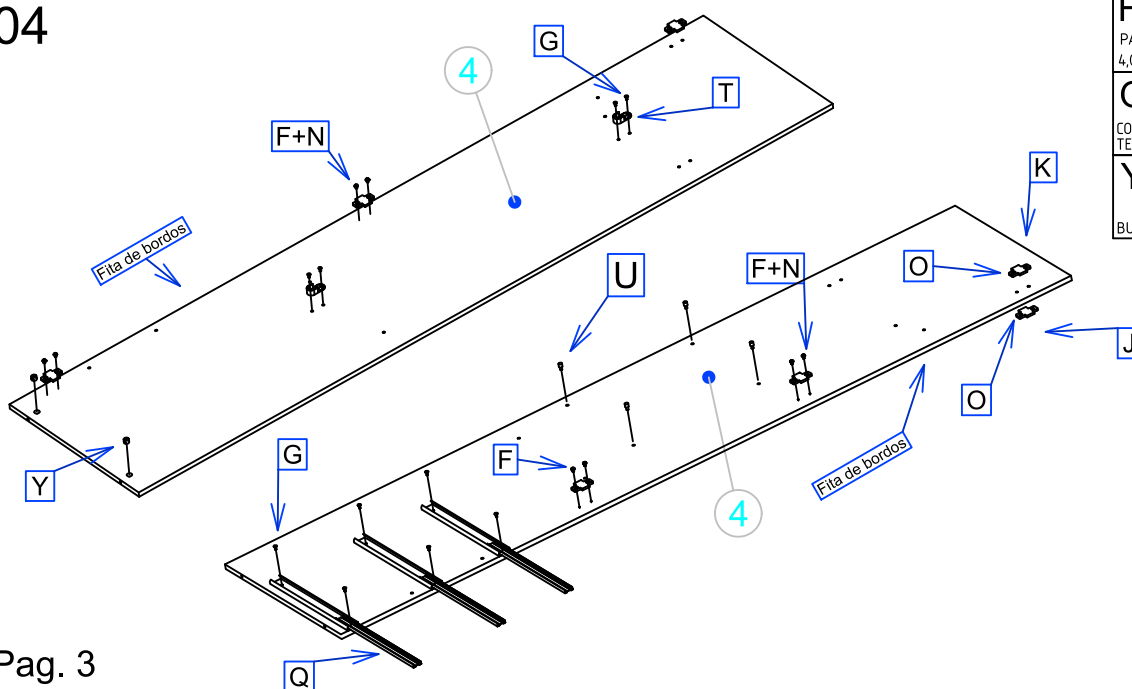

F		8
Q		3
Y		2
T		2
U		4
G		10
O		6
J		2
K		2

05

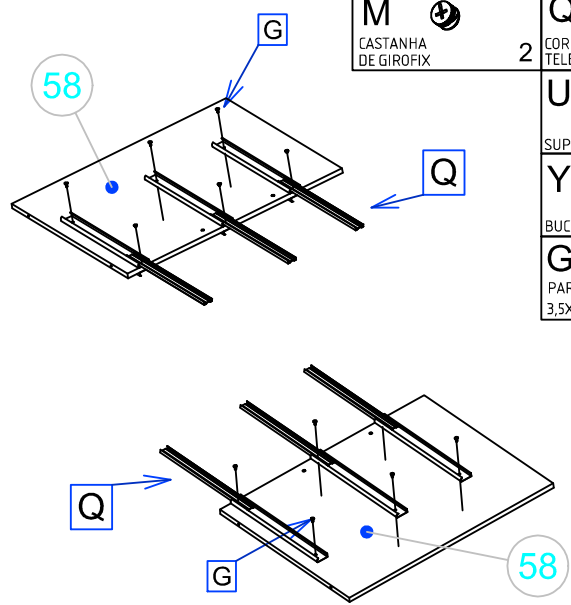
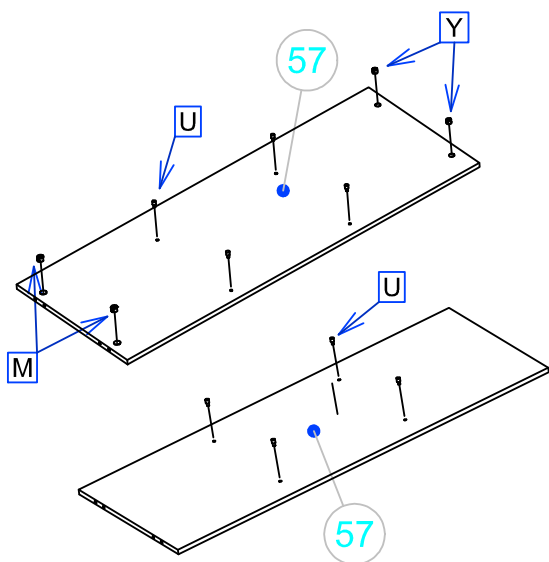

M  
CASTANHA DE GIROFIX

Q  
CORREDIÇA TELESCÓPICA 6

U  
SUPORTE PRAT. 8

Y  
BUCHA CILINDRICA 2

G  
PARAFUSO 3,5X12 CHATO 12

06

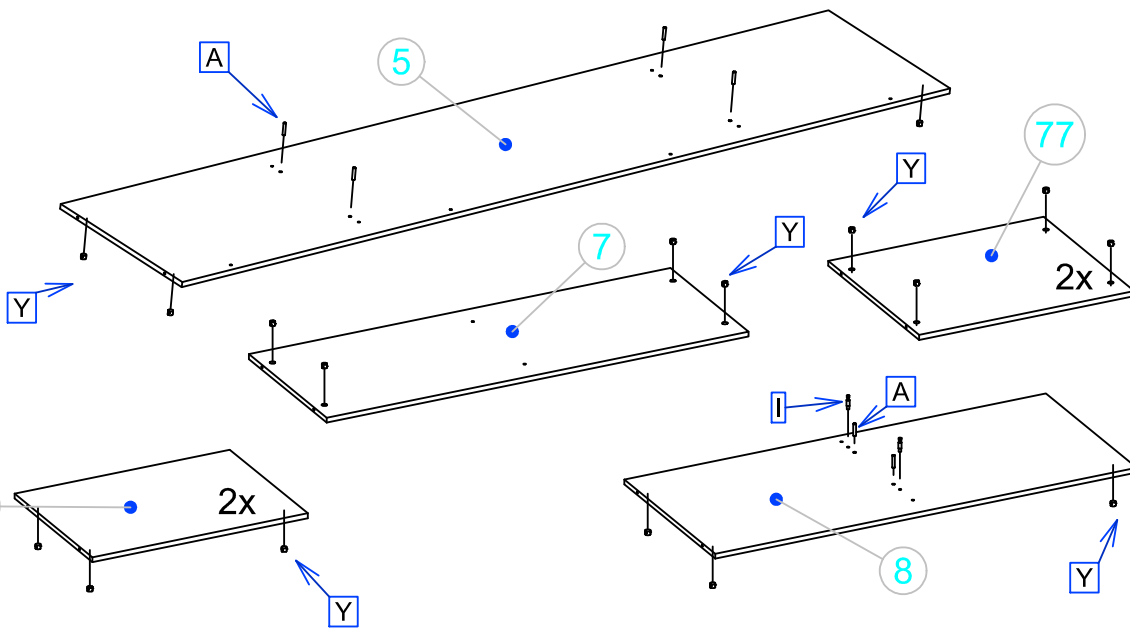

Y  
BUCHA CILINDRICA 32

A  
CAVILHA 6X30 6

I  
PINO DE GIROFIX 2

07

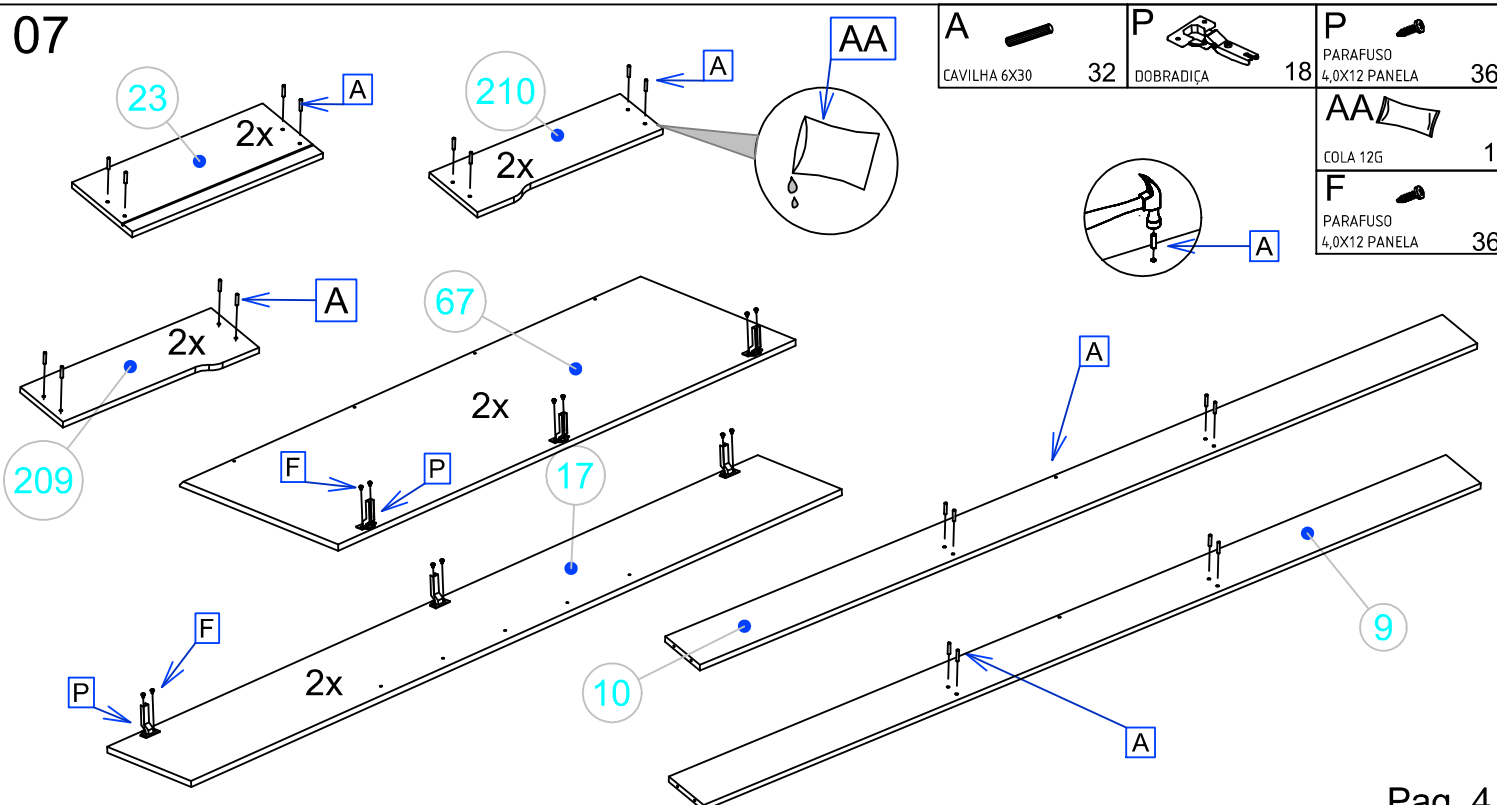

A  
CAVILHA 6X30 32

P  
DOBRADIÇA 18

P  
PARAFUSO 4,0X12 PANELA 36

AA  
COLA 12G 1

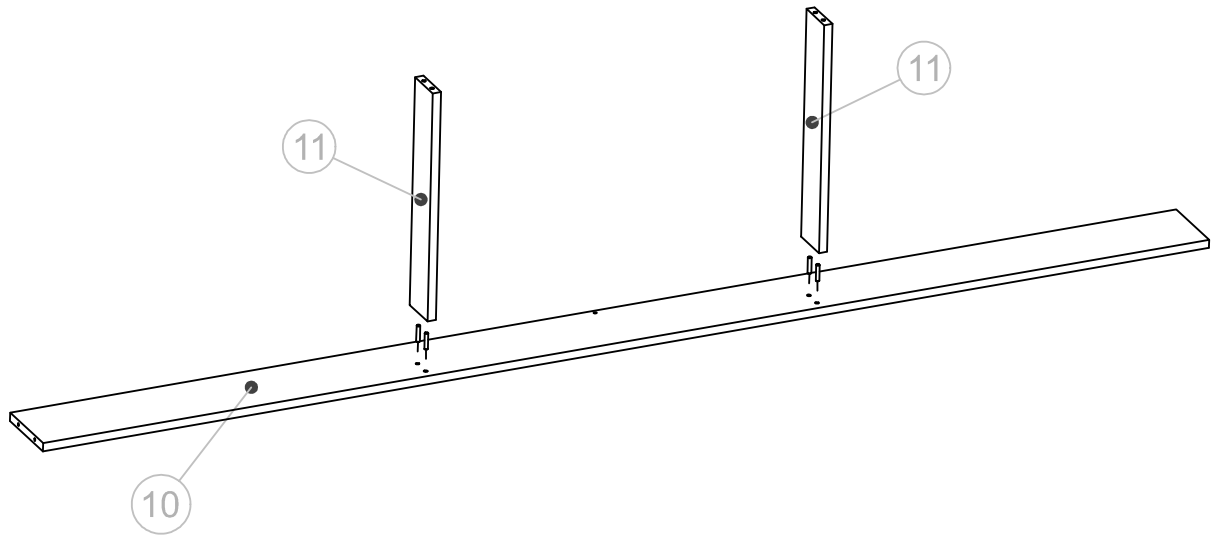

F  
PARAFUSO 4,0X12 PANELA 36

04



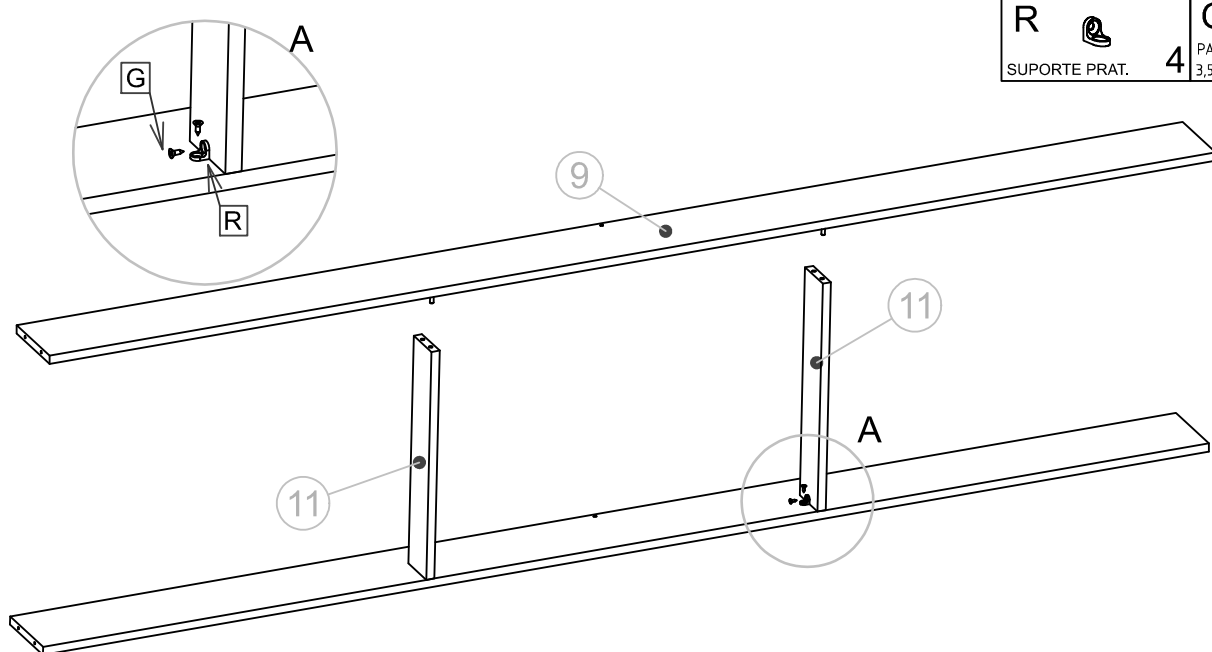

05

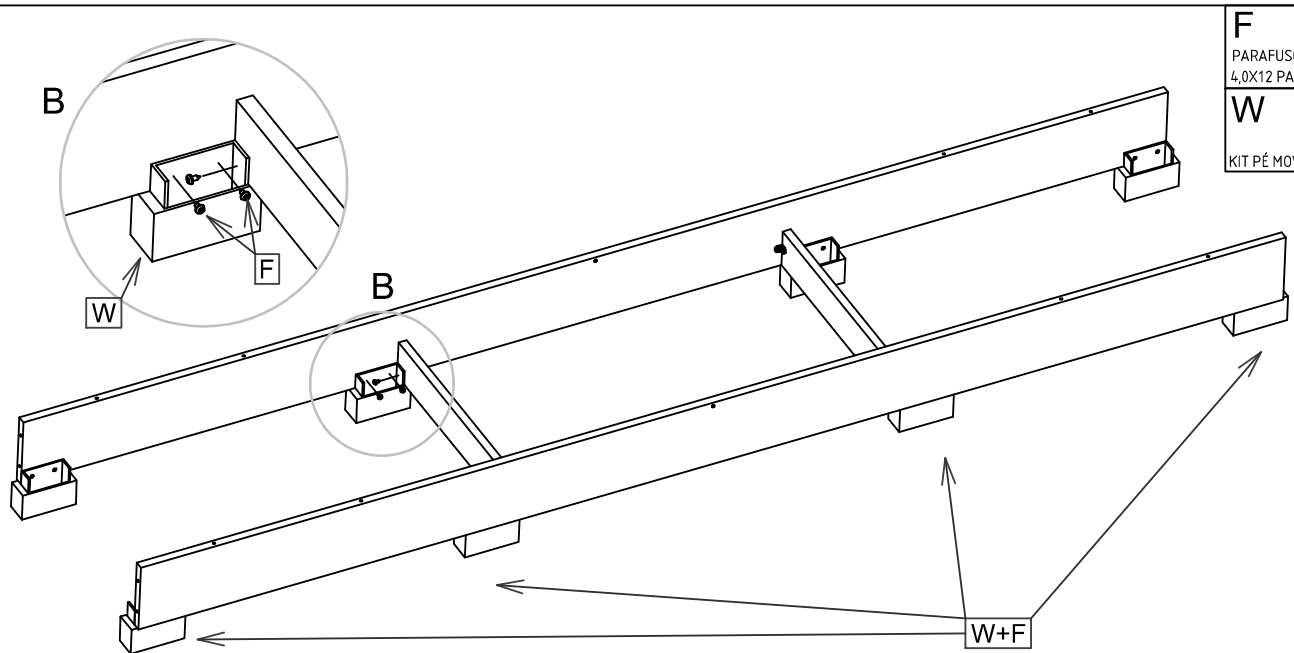

R		4	G		8
SUPORTE PRAT.			PARAFUSO 3,5X12 CHATO		

06



F		20
PARAFUSO 4,0X12 PANELA		
W		8
KIT PÉ MOVAL		

07

D  
Parafuso  
4,0x35 CHATO 2

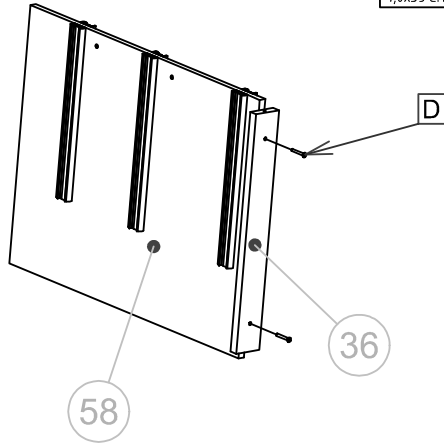

09

F  
PARAFUSO  
4,0X12 PANELA 4  
D  
Parafuso  
4,0x35 CHATO 8

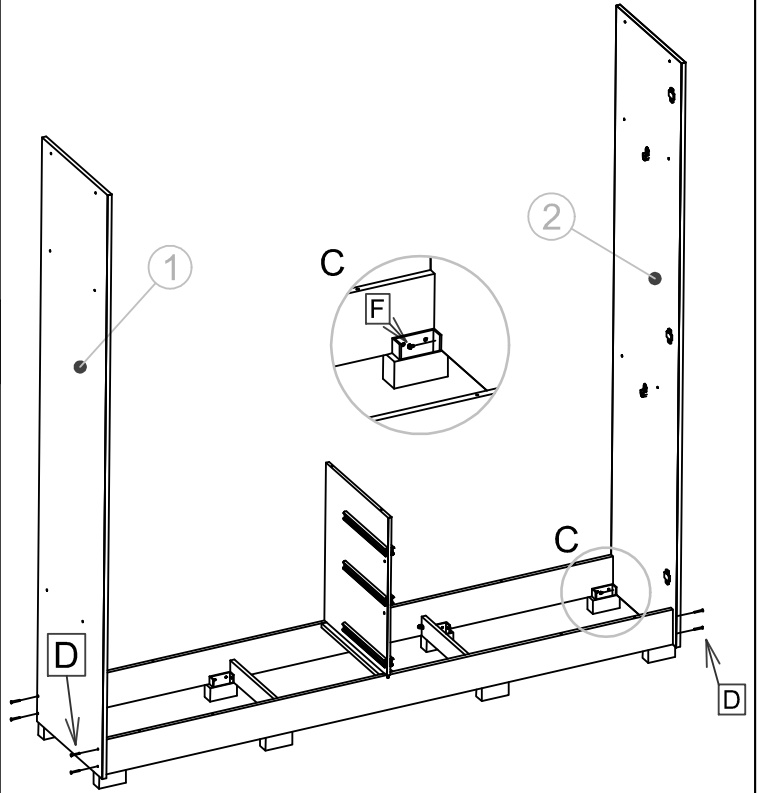

08

D  
Parafuso  
4,0x35 CHATO 2

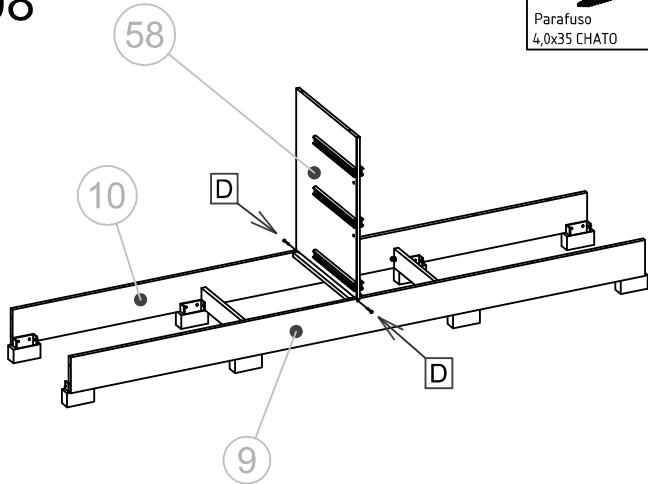

10

C  
PAR 4,0X50 CHATO 2

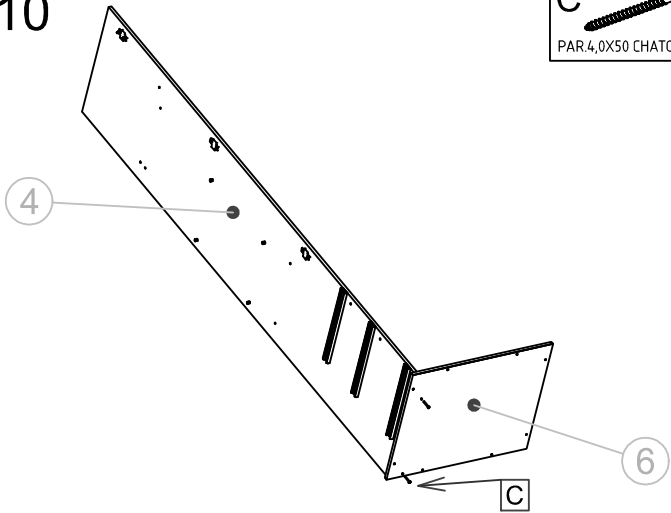

12

D  
Parafuso  
4,0x35 CHATO 4

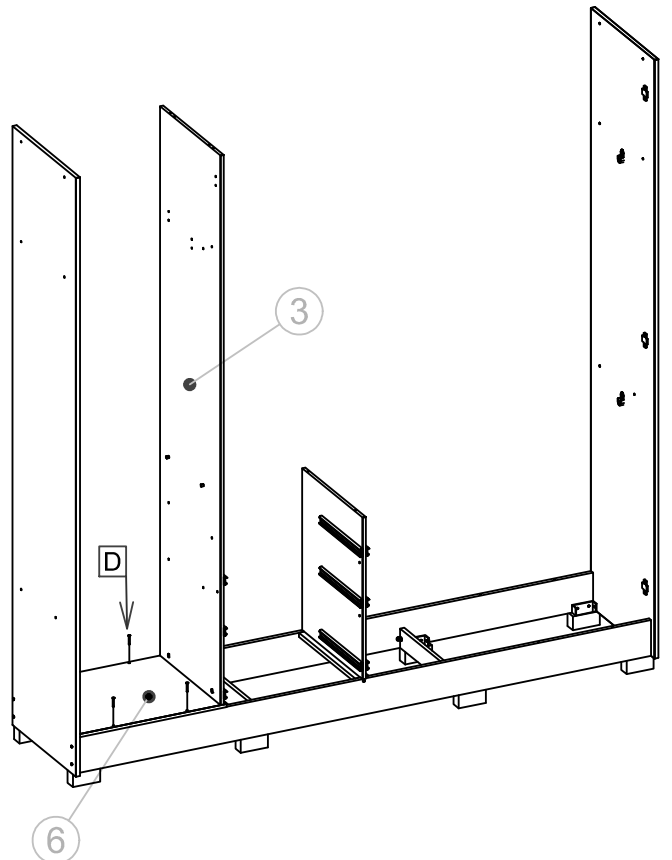

11

C  
PAR 4,0X50 CHATO 2

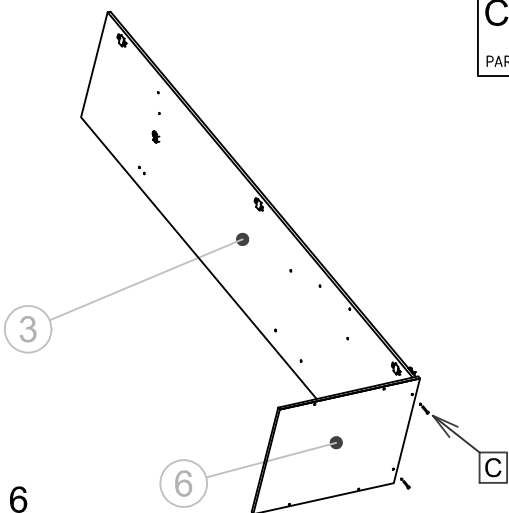

13

C  
PAR 4,0X50 CHATO 4

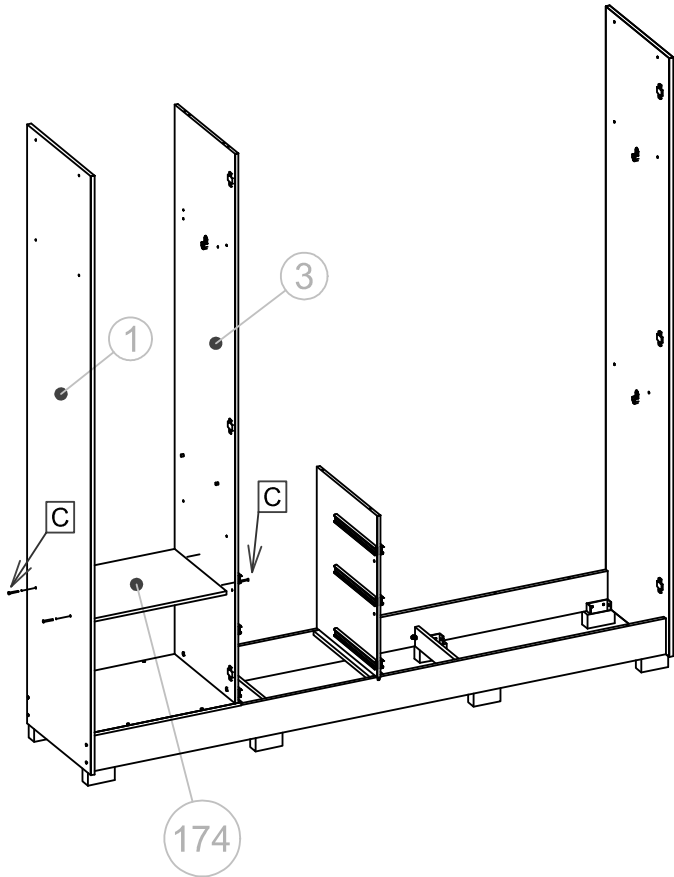

14

C PAR 4,0X50 CHATO 2  
B CAVILHA 6X50 2

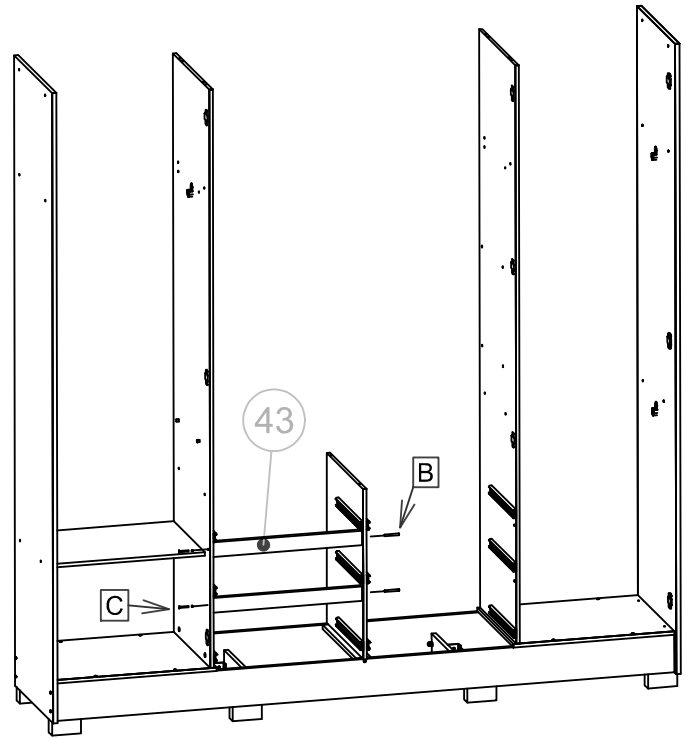

15

D  
Parafuso  
4,0x35 CHATO 4

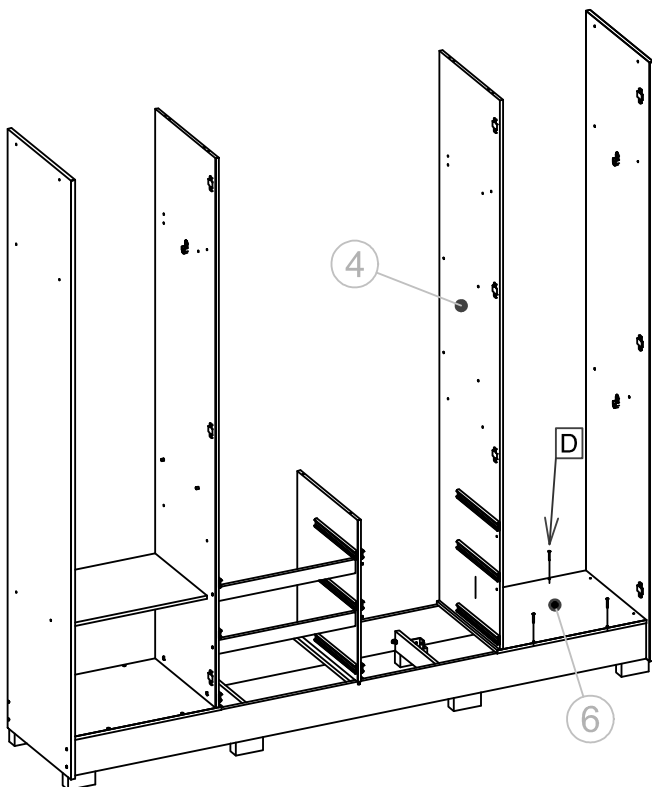

16

C  
PAR 4,0X50 CHATO 2

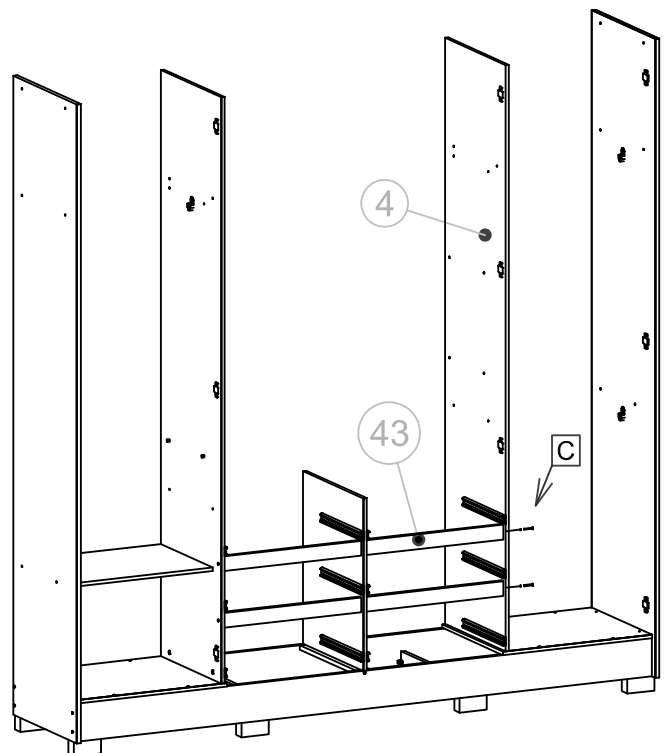

17

G  
PARAFUSO  
3,5X12 CHATO

16

R  
SOPORTE PRAT.

8

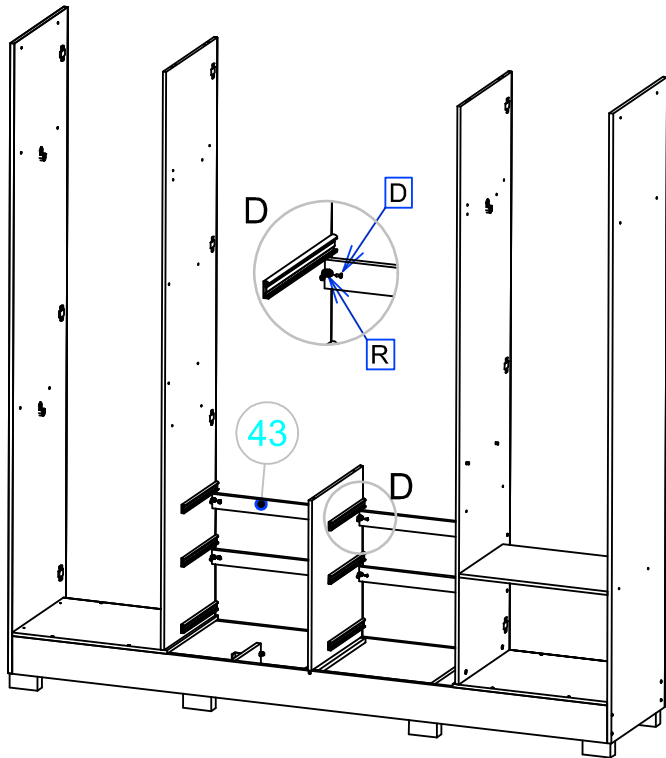

18

C  
PAR 4,0X50 CHATO

4

D  
Parafuso  
4,0x35 CHATO

2

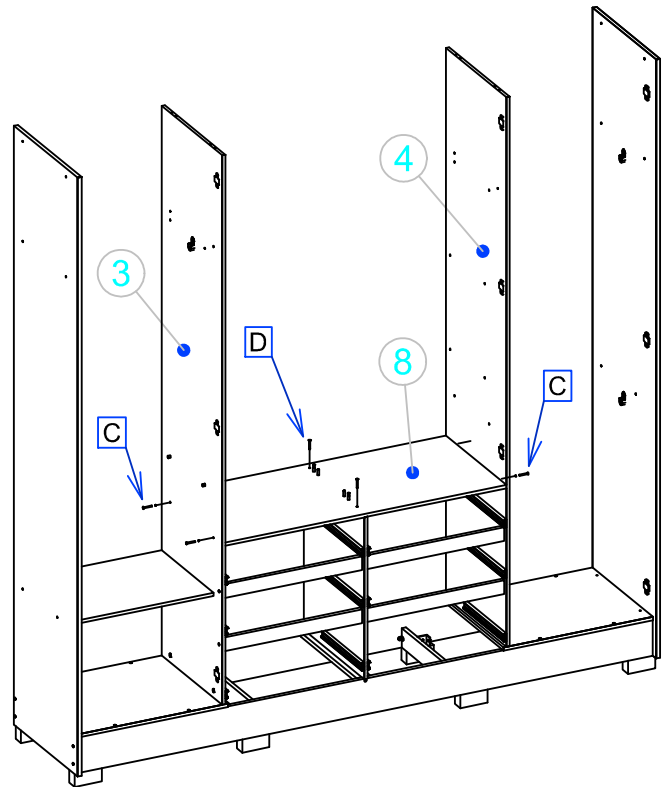

19

C  
PAR 4,0X50 CHATO

4

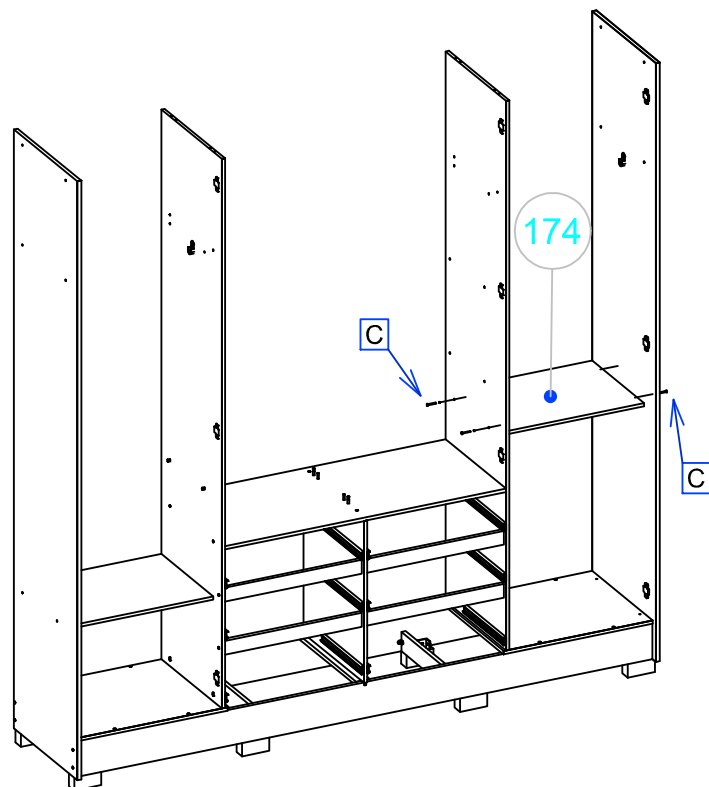

20

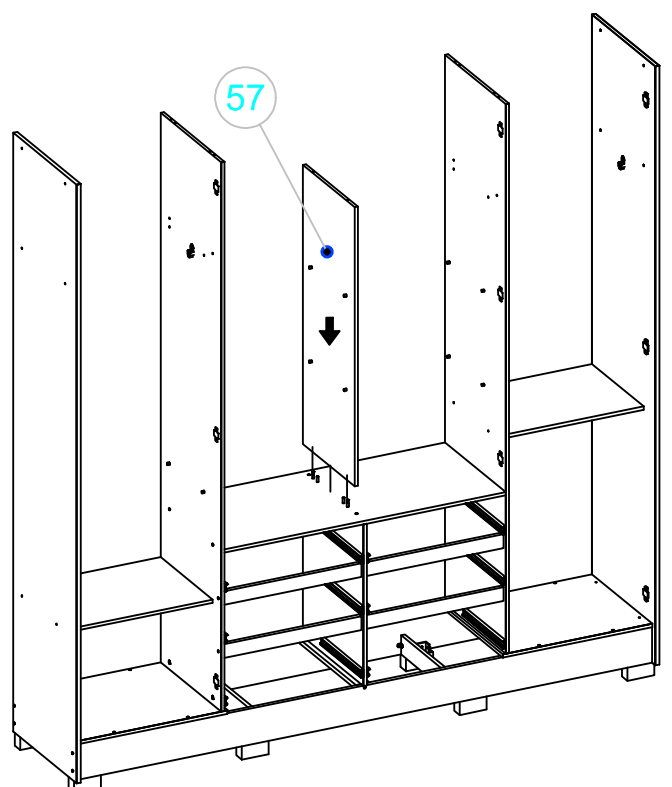
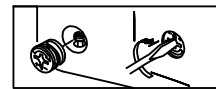

21



6

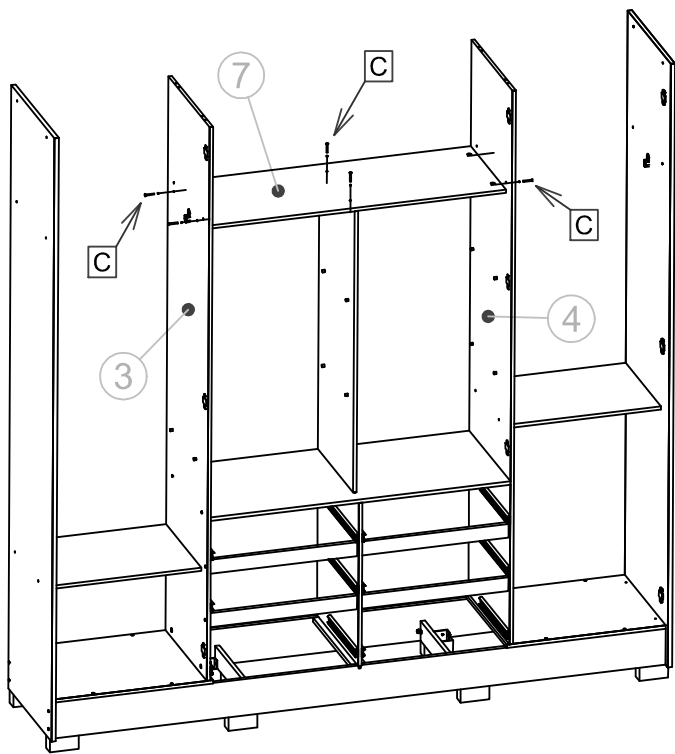

22



8

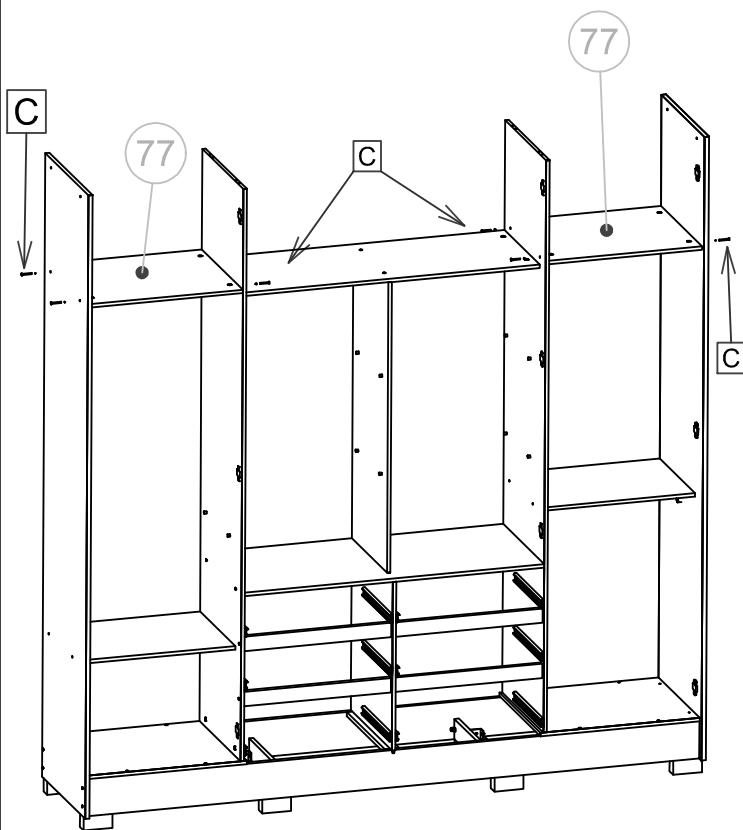

23



4



4

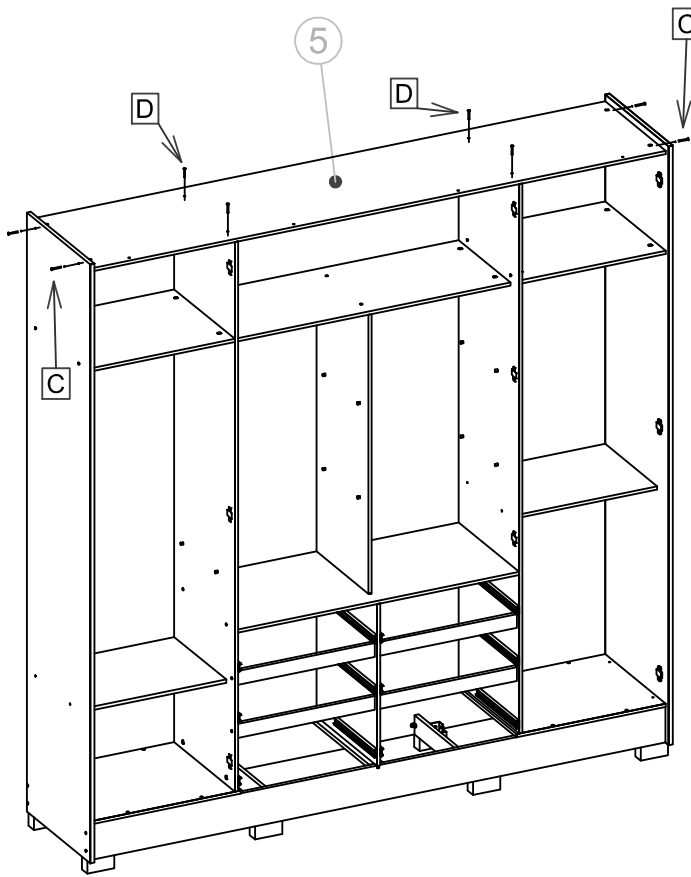

24

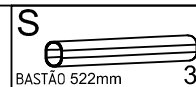

3



4

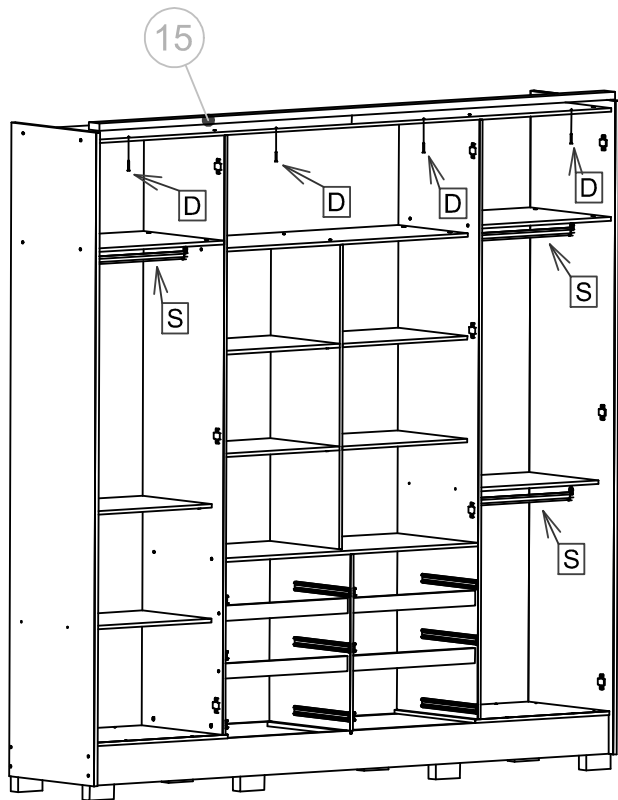

25

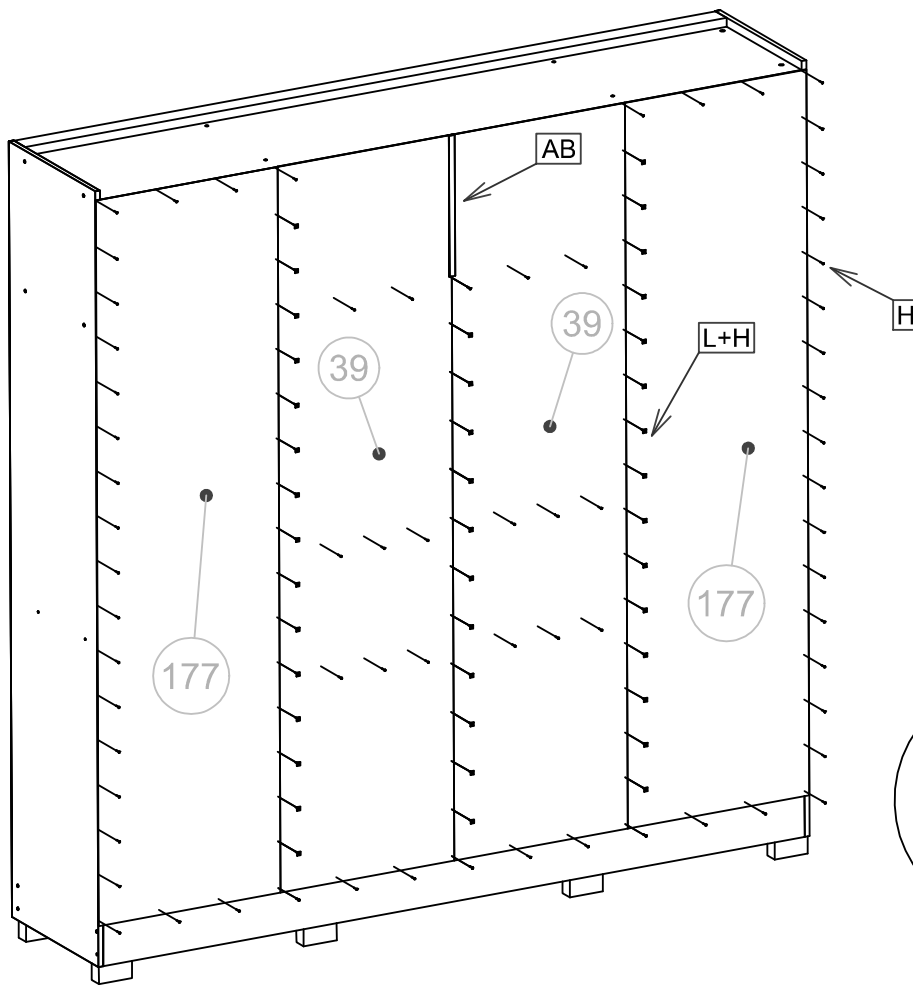

H		
PREGO 10X10		141
L		
FIXADOR RETO		41
AB		
PERFIL I 394mm		1

26

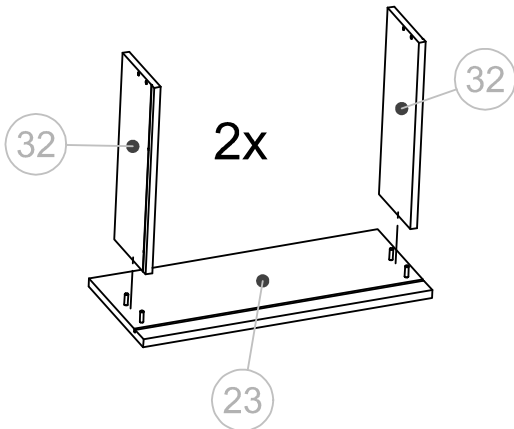

27

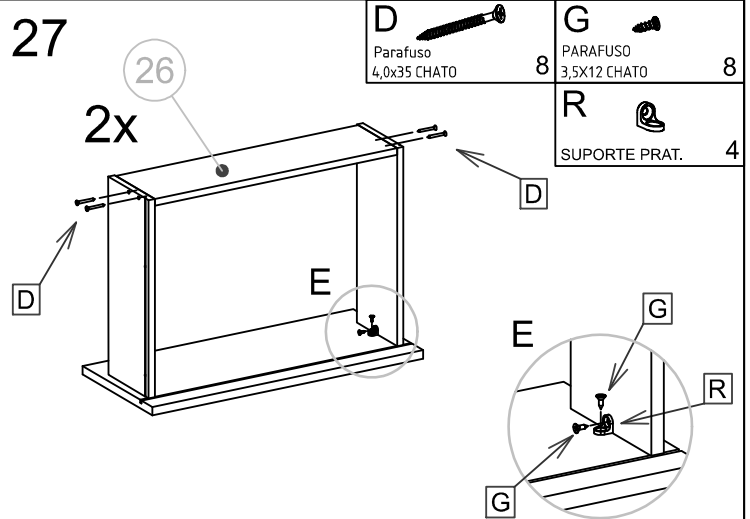

D		
Parafuso 4,0x35 CHATO		8
G		
PARAFUSO 3,5X12 CHATO		8
R		
SUPORTE PRAT.		4

28

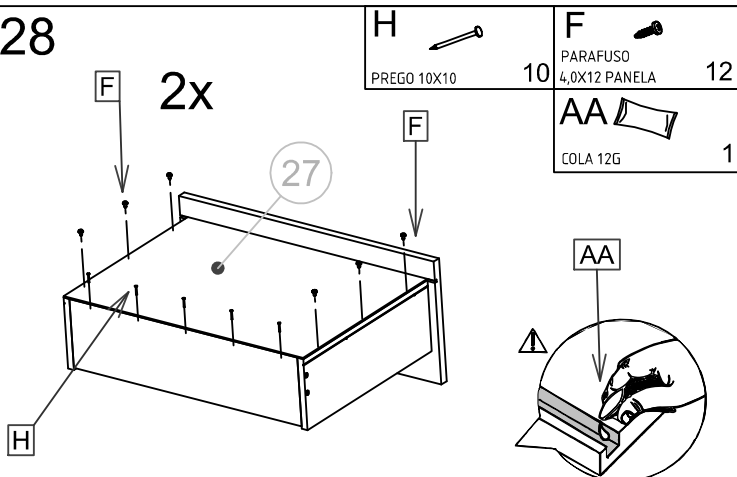

H		
PREGO 10X10		10
F		
PARAFUSO 4,0X12 PANELA		12
AA		
COLA 12G		1

29

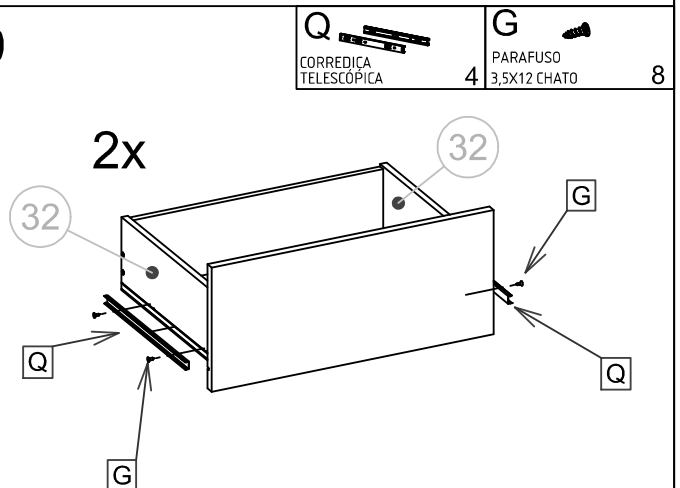

Q		
CORREIJA TELESCÓPICA		4
G		
PARAFUSO 3,5X12 CHATO		8

30

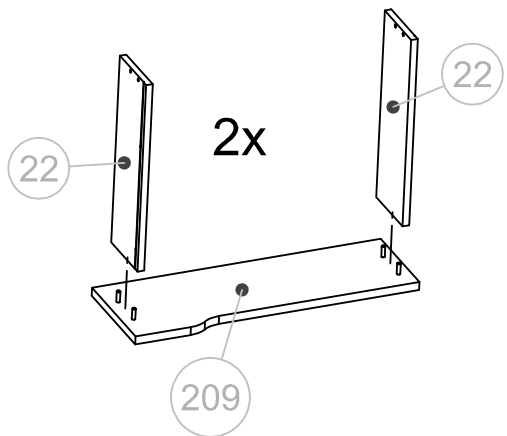

31

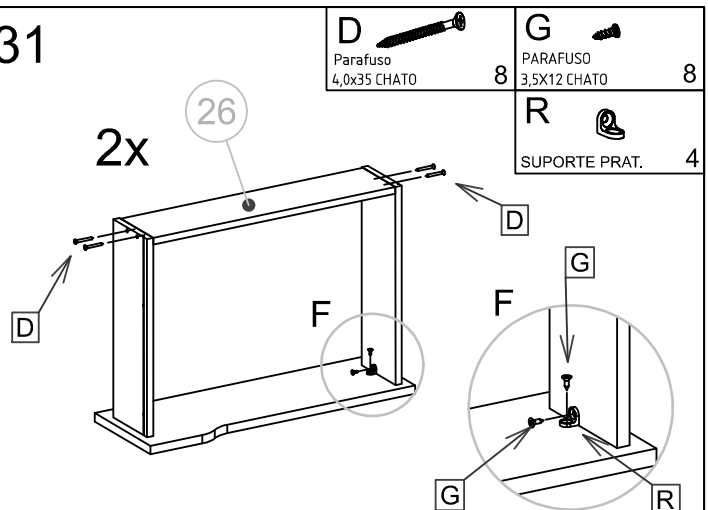

32

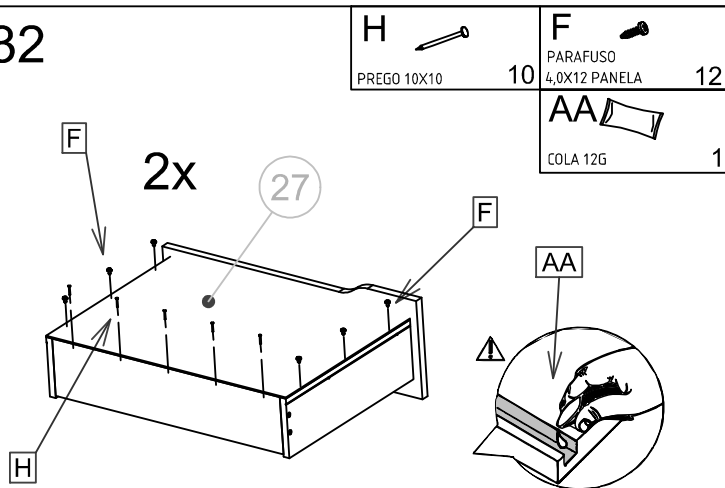

33

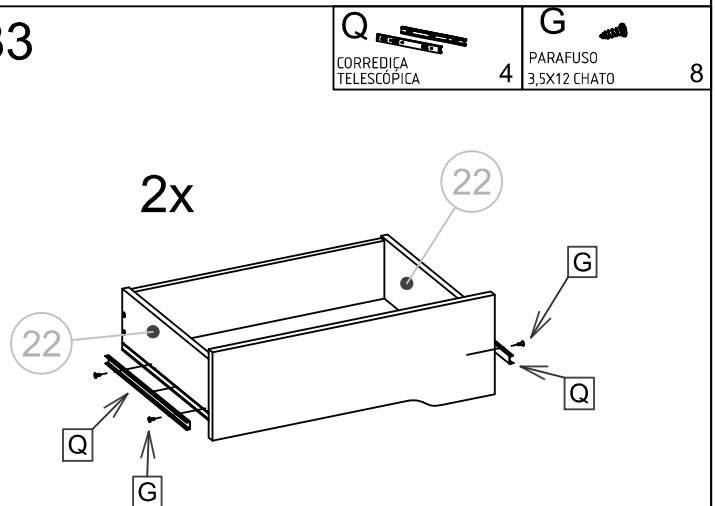

34

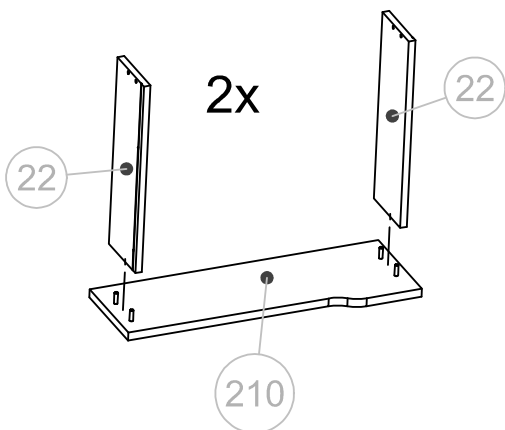

35

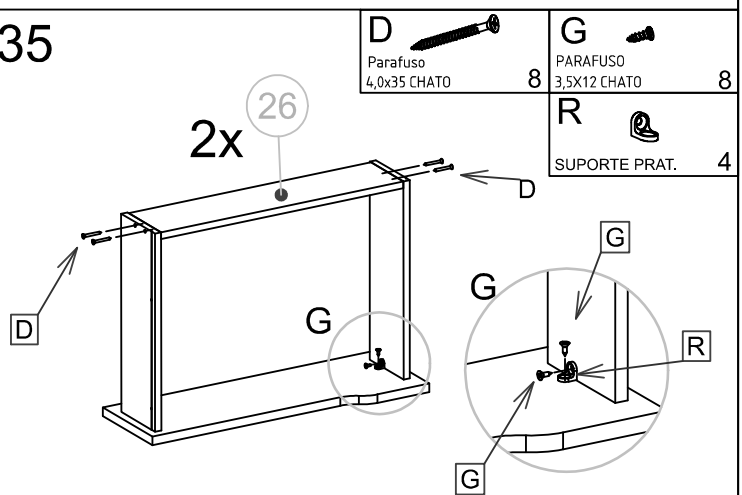

36

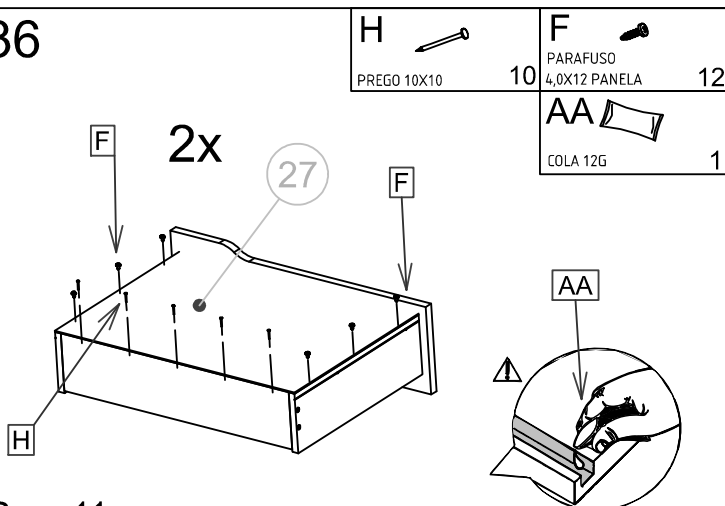

37

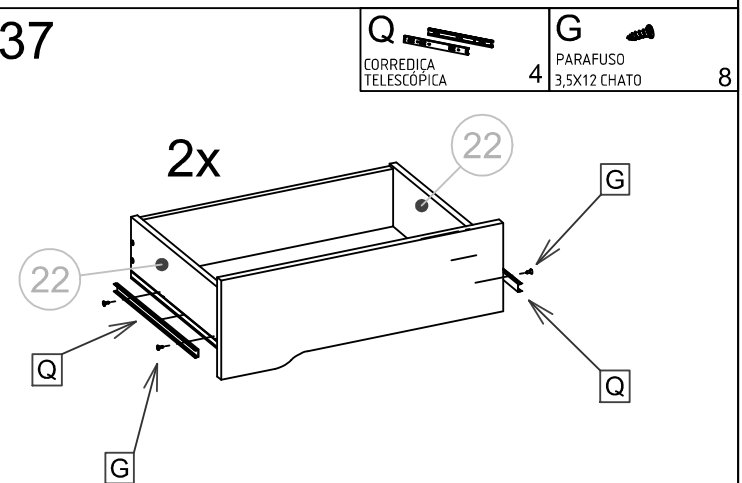

38

E   
PARAFUSO 3,5X25

4

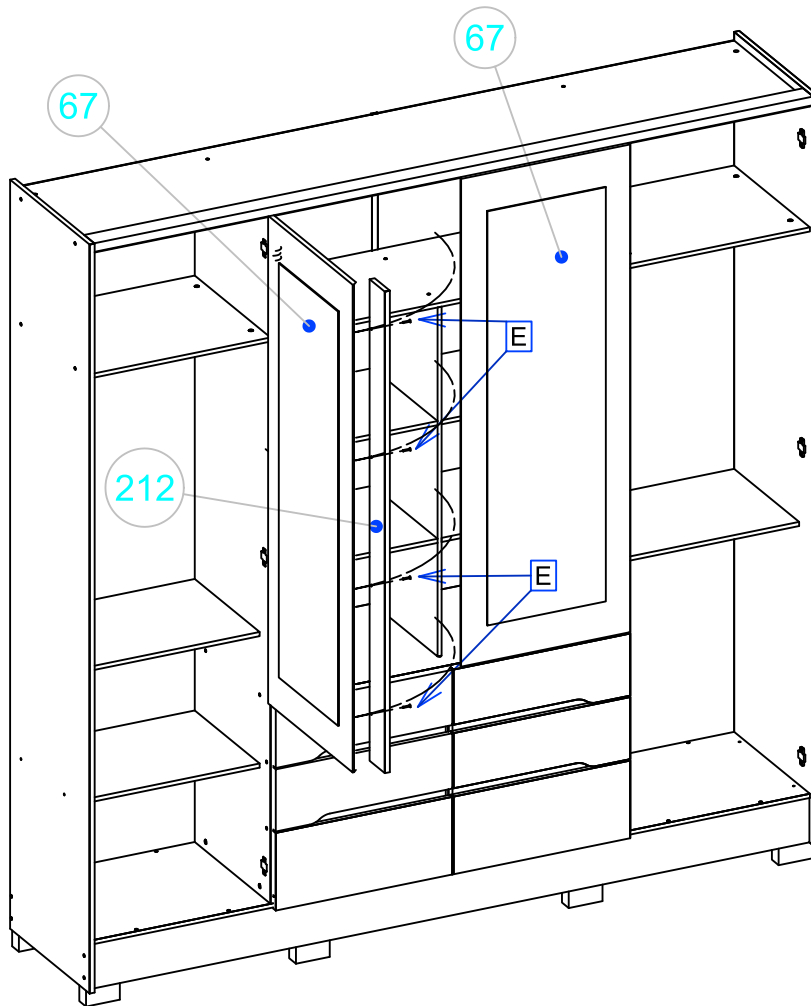

39

AC   
ETIQUETA LIT 1  
E   
PARAFUSO 3,5X25 12  
Z   
PUX. MDF 480mm 4

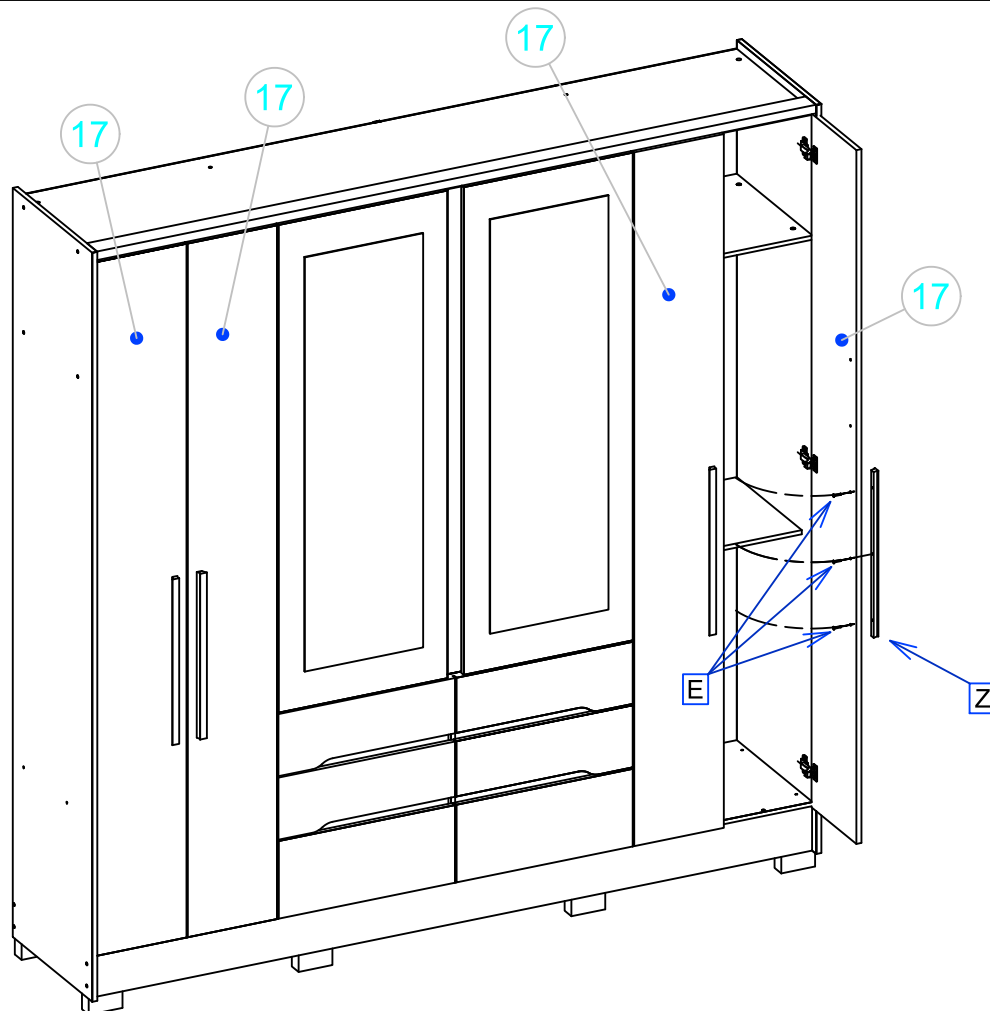

DESCRIÇÃO	QT.	OL._CX.	COMP.	LARG.	ESP.	MAT._PRIMA
DIVISÓRIA CENTRAL/DIVISIÓN CENTRAL/CENTRAL DIVISION	1	4	1011	384	12.0	MDP
DIVISÓRIA DA GAVETA/DIVISIÓN DE LA CAJONERA/DRAWER DIVISION	1	4	586	448	12.0	MDP
DIVISÓRIA DIREITA/DIVISIÓN DERECHA/RIGHT DIVISION	1	4	1991	448	12.0	MDP
DIVISÓRIA ESQUERDA/DIVISIÓN IZQUIERDA/LEFT DIVISION	1	4	1991	448	12.0	MDP
ENCABEÇAMENTO/TECHO/HEADER	1	2	2126	60	25.0	MDP
FRENTE DA GAVETA DIREITA / FRENTE DEL CAJON LARGA / FRONT DRAWER GREATER	2	1	522	180	15.0	MDP
FRENTE DA GAVETA ESQUERDA /FRENTE DEL CAJON IZQUIERDA/FRONT DRAWER GREATER	2	1	522	180	15.0	MDP
FRENTE DE GAVETA/FRENTE DE LA CAJONERA/FRONT DRAWER	2	1	522	225	15.0	MDP
FUNDO DA GAVETA/FONDO DEL CAJON/BOTTOM DRAWER	6	1 / 4	491	355	2.5	HDF
LATERAL DA GAVETA MAIOR/LATERAL DE CAJON LARGA/SIDE DRAWER GREATER	4	4	350	130	12.0	MDP
LATERAL DA GAVETA/LATERAL DE LA CAJONERA/SIDE DRAWER	8	4	350	109	12.0	MDP
LATERAL DIREITA/LATERAL DERECHA/RIGHT SIDE	1	4	2170	470	15.0	MDP
LATERAL ESQUERDA/LATERAL IZQUIERDA/LEFT SIDE	1	4	2170	470	15.0	MDP
PORTA CENTRAL/PUERTA CENTRAL/CENTRAL DOOR	2	5	1413	500	15.0	MDP
PORTA INTEIRA/PUERTA LARGA/BIGGEST DOOR	4	1	2010	265	15.0	MDP
PRATELEIRA / ESTANTE / SHELF	1	1	531	384	12.0	MDP
PRATELEIRA CENTRAL/ESTANTE CENTRAL/CENTRAL SHELF	4	2	514	384	12.0	MDP
QUADRO /CUADRO / SQUARE	2	3	531	384	12.0	MDP
QUADRO BASE/CUADRO BASE/BASE SQUARE	2	3	553	448	12.0	MDP
QUADRO CENTRAL LATERAL/CUADRO CENTRAL LATERAL/SIDE CENTRAL SQUARE	2	4	531	448	12.0	MDP
QUADRO CENTRAL/CUADRO CENTRAL/SQUARE CENTRAL	1	4	1040	384	12.0	MDP
QUADRO CHAPÉU/CUADRO TECHO/HAT SQUARE	1	2	2126	448	12.0	MDP
QUADRO INTERNO/CUADRO INTERNO/SQUARE INTERNAL	1	4	1040	448	12.0	MDP
RODAPÉ FRONTAL/ZOCALO FRONTAL /FRONT BASEBOARD	1	2	2126	130	15.0	MDP
RODAPÉ TRASEIRO/ZOCALO TRASERO/BACK BASEBOARD	1	2	2126	130	15.0	MDP
SANEFLA DA PORTA / PUERTA SANFELA / DOOR SANEFLA	1	2	1395	90	15.0	MDP
SANEFLA/SANEFLA/SIGHT	4	1	514	50	15.0	MDP
TRASEIRO CENTRAL/TRASERO CENTRAL DEL ROPERO/BACK CENTRAL CLOSET	2	1	2030	526	2.5	HDF
TRASEIRO DA GAVETA/TRASERO DEL CAJON/BACK DRAWER	6	3	467	105	12.0	MDP
TRASEIRO LATERAL / TRASERO LATERAL / SIDE BACK	2	1	2030	550	2.5	HDF
TRAVA DA DIVISÓRIA/TRABA DE LA DIVISIÓN/CONSTRAINT DIVISION	1	2	415	50	15.0	MDP
TRAVA DO RODAPÉ/TRABA DEL ZOCALO/CONSTRAINT BASEBOARD	2	2	415	70	15.0	MDP