

OFFICE CHAIR

Assembly Instructions

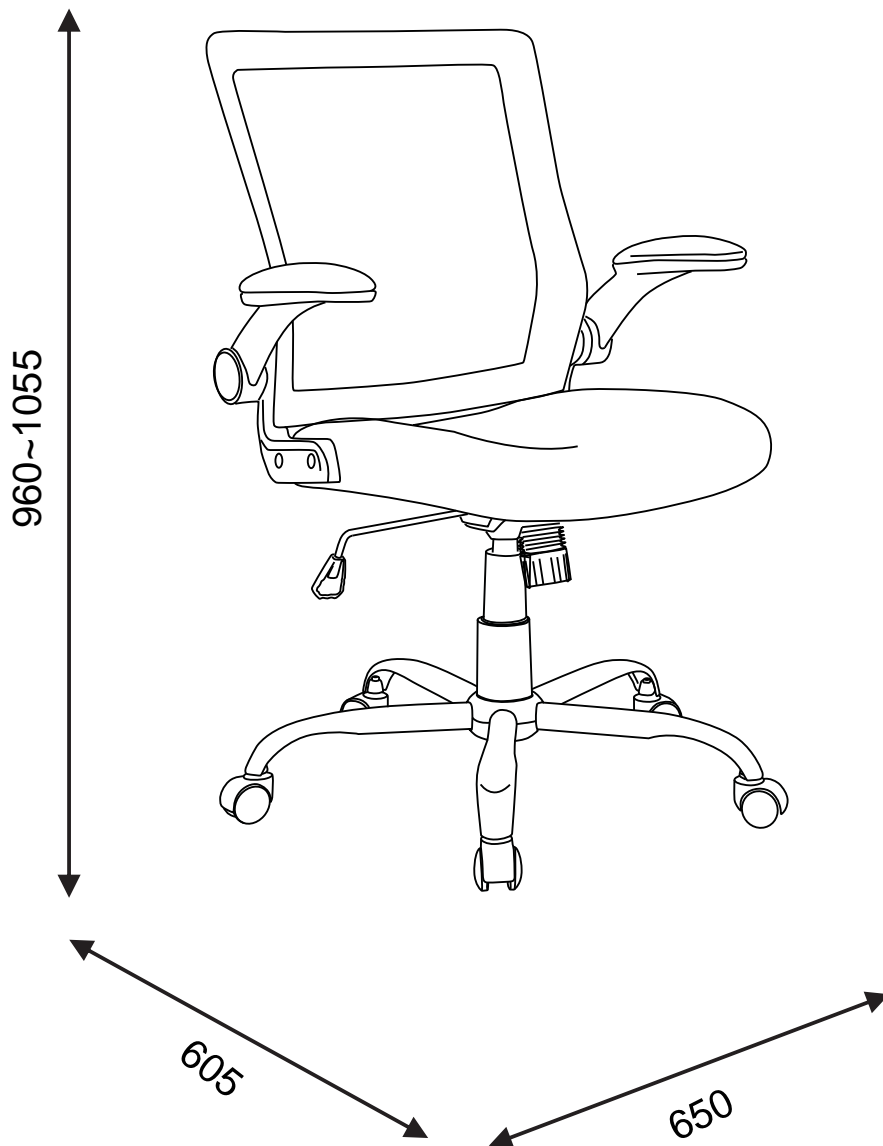



NO TOOLS
REQUIRED.

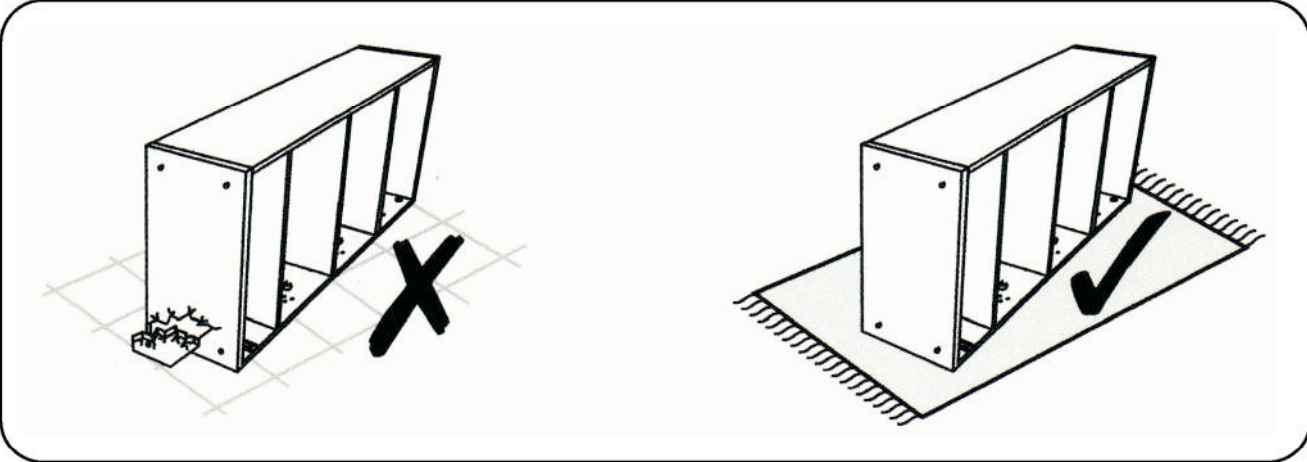
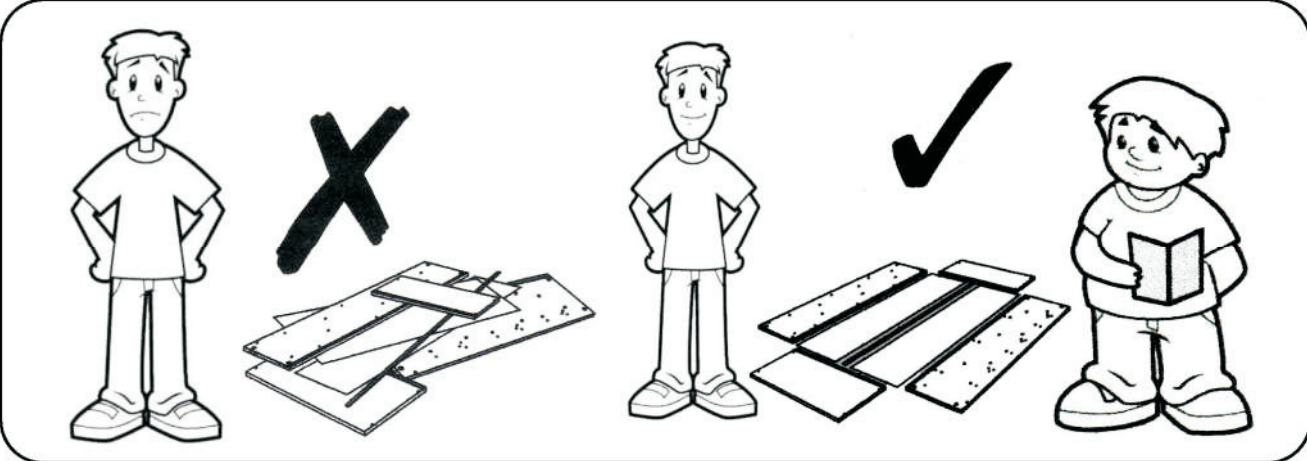
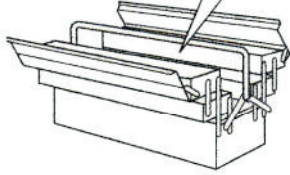

Hardware

A



4X

M6*20

B



4X

M6*22

C



4X

D



1X

M6

PARTS

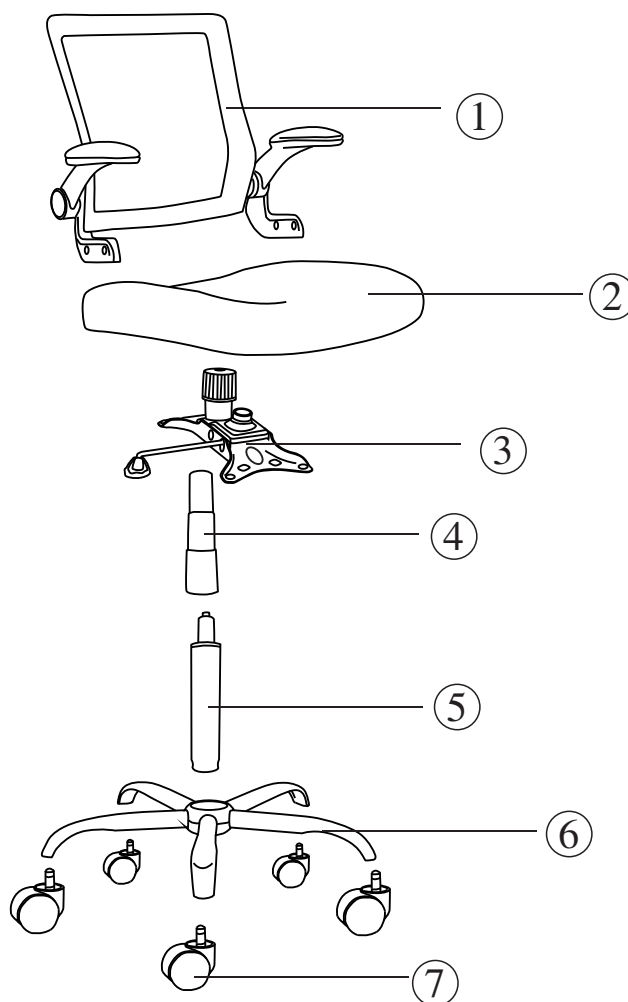

Safety Advice

Please take the time to carefully read through the whole of these instructions before you commence.

Keep these instructions for future reference.

Unpack, inspect and check off all of the contents.

Please dispose of all packaging safely.

Small component parts could choke a child if swallowed.

We strongly recommend that you keep children well away from the work area.

It would be sensible to lay a sheet or blanket on the floor where you intend to work to avoid scratching this product and to protect your floor.

This product is heavy. Take extreme care when lifting to avoid personal injury or damage to the product.

Assemble the product as close to its intended final position in the room as possible.

HANDY HINT: If you keep the hardware in a bowl during assembly you will be less likely to lose them.

Please do not tighten the bolts until the chair is fully assembled

1

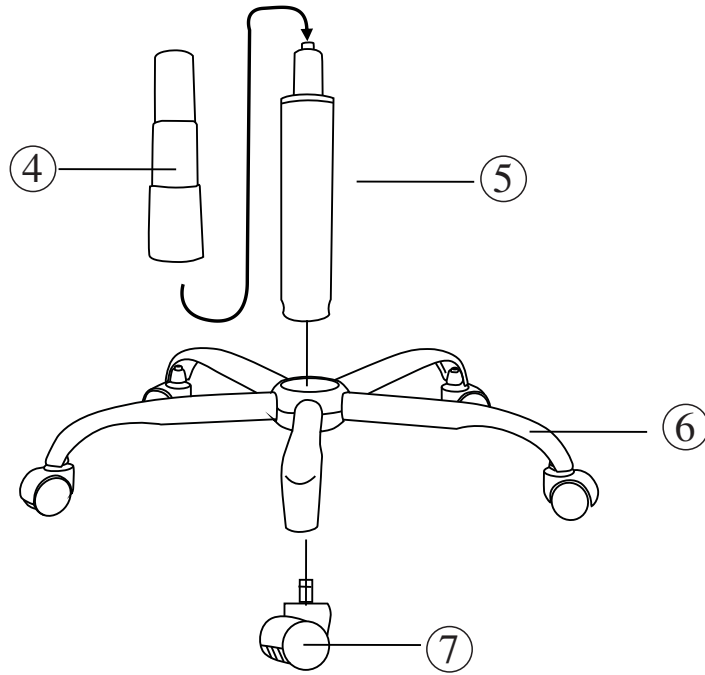

2

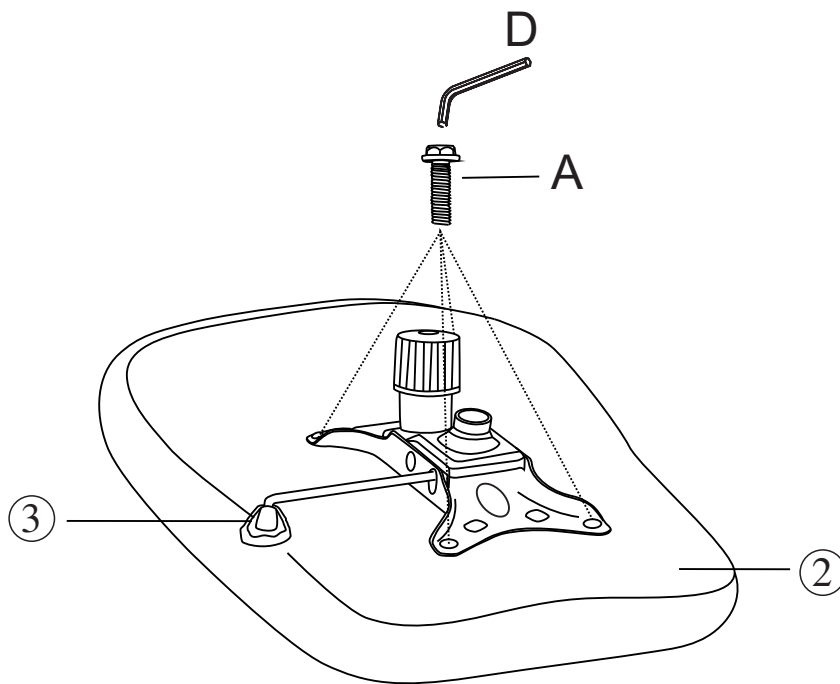

Do Not Use Power Tools

3

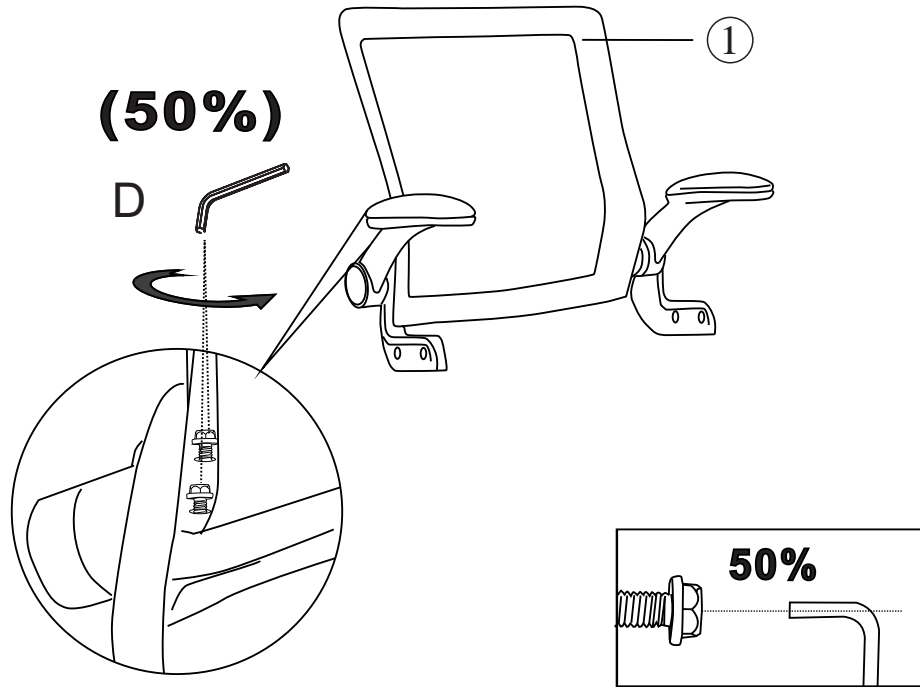

4

4



Do Not Use Power Tools

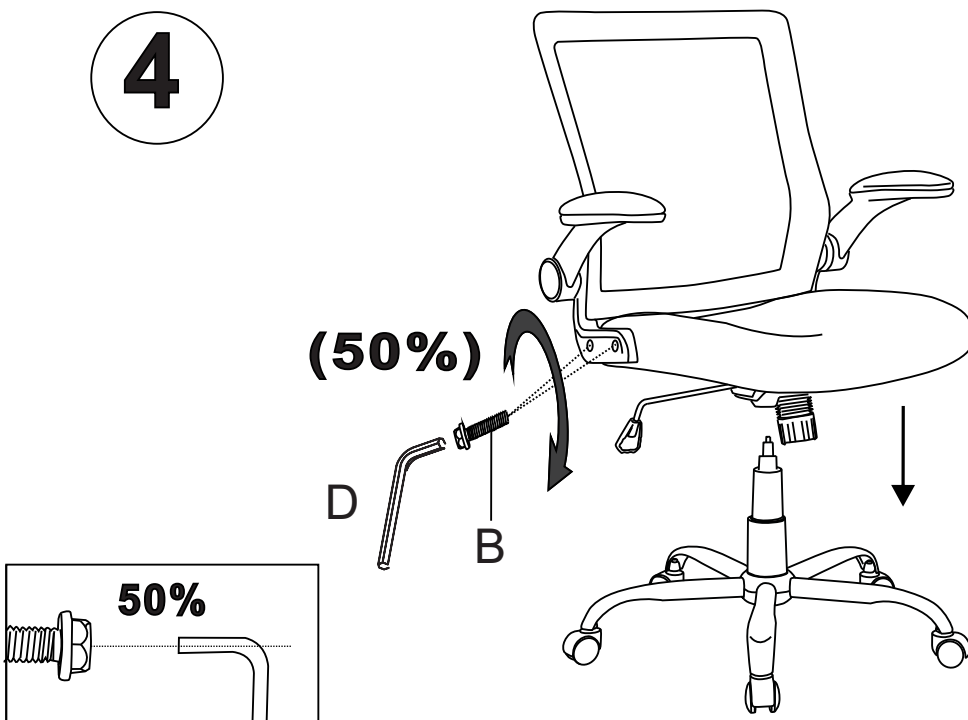

5

(100%)

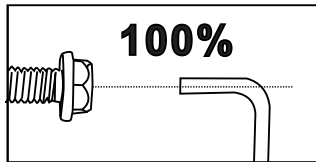
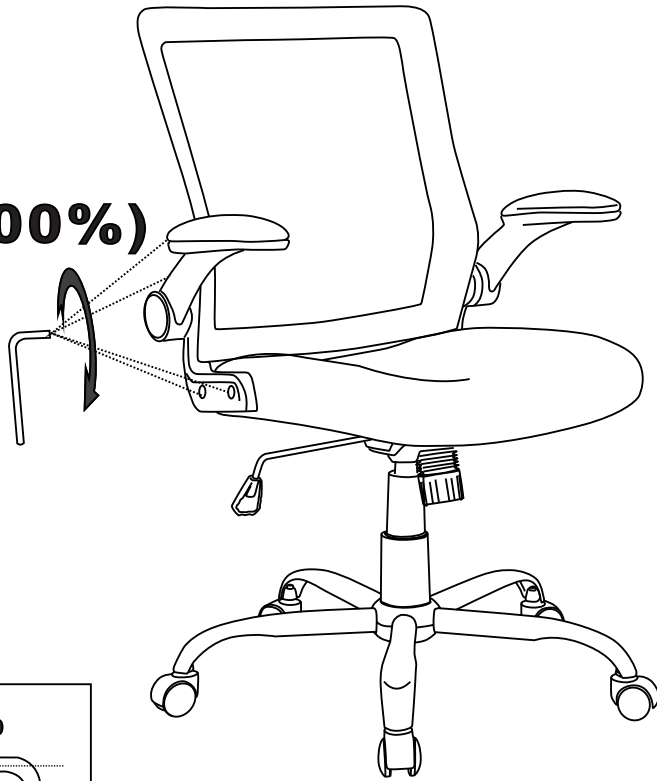

Do Not Use Power Tools

6

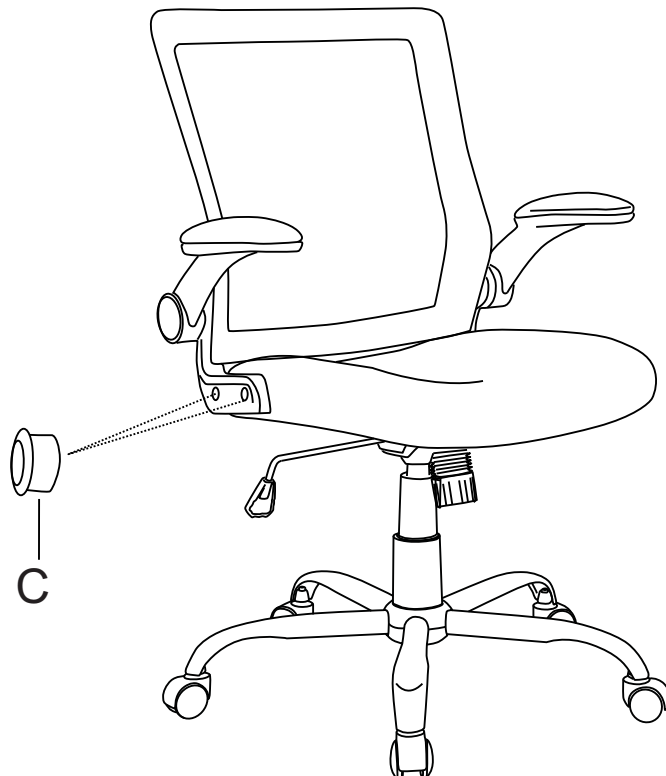

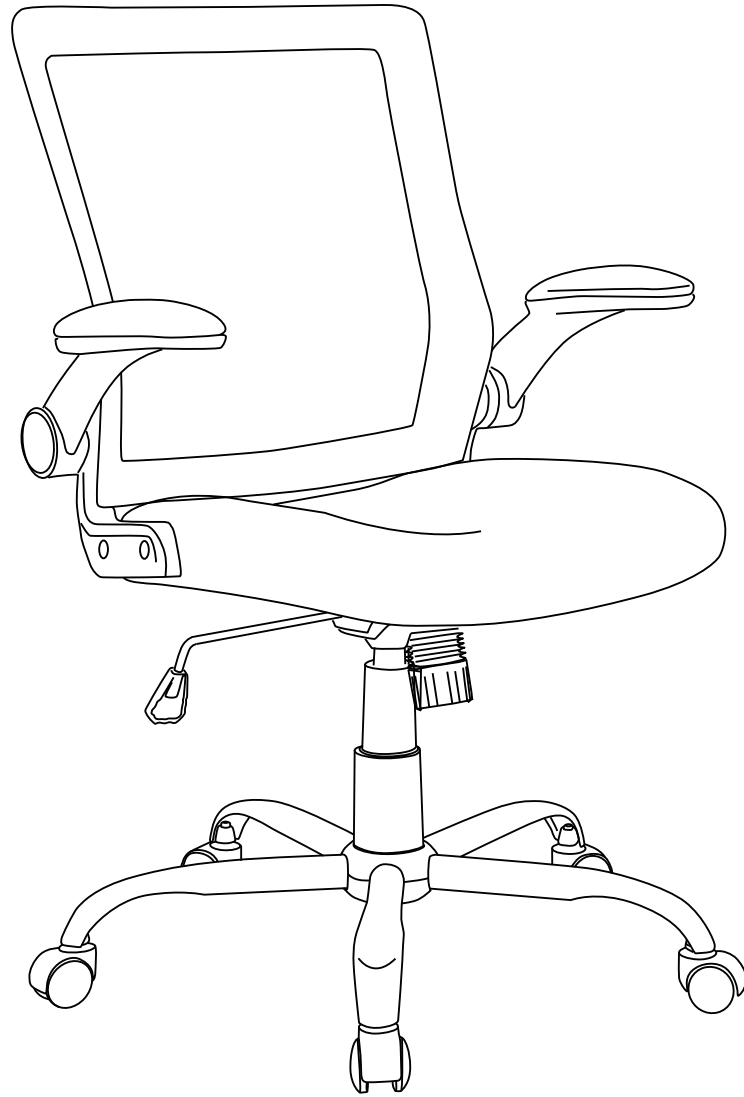

Your Office Chair is now ready for use

General Care

Wipe clean with a slightly damp soft cloth.

Avoid the use of all household cleaners and abrasives.

When moving your furniture, carefully lift into place.

Never drag or push the pieces across the floor as this will cause damage to the joints and could result in failure to the product that will invalidate the warranty.

Recommendations

Periodical re-tightening of fixings.

Warning

This unit is heavy. Please use an assistant when lifting.