

THIS INSTRUCTION BOOKLET CONTAINS **IMPORTANT** SAFETY INFORMATION. PLEASE READ AND KEEP FOR FUTURE REFERENCE.

ESTE FOLLETO DE INSTRUCCION CONTIENE INFORMACION **IMPORTANTE** DE SEGURIDAD. POR FAVOR LEA Y GUARDE PARA REFERENCIA FUTURA.

CE LIVRET D'INSTRUCTIONS CONTIENT DES INFORMATIONS **IMPORTANTES** SUR LA SÉCURITÉ. S.V.P. LIRE ET CONSERVER POUR RÉFÉRENCE FUTURE.



**DO NOT RETURN PRODUCT TO THE STORE**  
Individual stores do not stock parts.

**NO DEVUELVA ESTE PRODUCTO A LA TIENDA**  
Las tiendas no almacenan partes.

**NE PAS RETOURNER LE PRODUIT AU MAGASIN.**  
Les magasins individuels ne tiennent pas les pièces en inventaire.

Lot Number / Número de Lote / Numéro de lot: \_\_\_\_\_

Date Of Purchase / Fecha de Compra / Date d'achat: \_\_\_\_ / \_\_\_\_ / \_\_\_\_

**If a part is missing or damaged, call our toll-free customer service line. We will gladly ship your replacement parts FREE of charge.**

**Si faltan partes o piezas, o éstas están dañadas, llame gratis al teléfono de servicio al cliente. Con gusto le enviaremos las partes sin cargo alguno.**

**Si une pièce est manquante ou endommagée, appelez sans frais notre ligne du service à la clientèle. Il nous fera plaisir de vous expédier les pièces de remplacement GRATUITEMENT.**

Need Parts or Assistance?  
Necesitas partes o asistencia?  
Besoin de pièces ou d'assistance?

access our website  
o visite nuestra página de internet  
ou visitez notre site Web

For prompt, reliable service please have your assembly manual ready.  
Para obtener servicio rápido y confiable, por favor tenga esta manual a la mano.  
Pour obtenir un service rapide et fiable, s.v.p. ayez en main votre manuel d'assemblage.

**Recommended # of people needed for assembly: 2**

**El número recomendado de personas necesarias para el montaje: 2**

**# de personnes recommandées pour l'assemblage: 2**

Before starting - Antes de empezar - Avant de débiter .

- Read each step carefully before starting. It is very important that each step of instruction is performed in the correct order. If these steps are not followed in sequence, assembly difficulties will occur.  
Leer con cuidado cada paso antes de empezar. Es muy importante de ejecutar cada paso en el orden correcto. Si los pasos no estan ejecutados en secuencia, ocurrirá dificultades en el montaje.  
Lisez attentivement chaque étape avant de commencer. Il est très important que chaque étape d'instruction soit effectuée dans l'ordre indiqué. Si ces étapes ne sont pas suivies dans l'ordre, des difficultés d'assemblage se produiront.
- Make sure all parts are included. Most board parts are labeled or stamped on the raw edge.  
Asegurar que todas las piezas son incluidas. La mayoría de las tablas tienen las etiquetas o los sellos en el lado sin acabado.  
Assurez-vous que toutes les pièces sont incluses. La plupart des panneaux sont étiquetés ou estampés sur le bord non fini.
- Work in spacious area, preferably on a carpet, near the place the unit will be used.  
Trabajar en una área espaciosa, preferible sobre alfombra, cercas del lugar donde se va a usar el mueble.  
Travaillez dans un endroit spacieux, préféablement sur un tapis, à proximité de l'endroit où le meuble sera utilisé.
- Have the following tools close at hand.  
Tener las herramientas siguientes cerca de la mano.  
Ayez à portée de la main, les outils suivants.
- Do not use power tools to assemble your furniture. Power tools may strip or damage the parts.  
No use herramienta eléctrica para montar su unidad. Las herramientas eléctricas pueden dañar las piezas.  
Ne pas utiliser d'outils électriques pour assembler votre mobilier. Les outils électriques peuvent briser ou endommager les pièces.

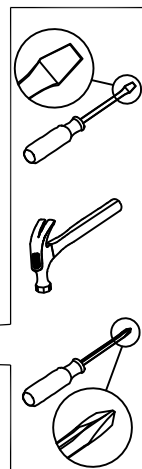
HELPFUL HINTS

- Visit our website for assembly video clips.
- Identify, sort and count the parts before attempting assembly.
- Call our toll free number if you need assistance identifying parts.
- Compression dowels are tapped in with a hammer.
- Slides have lips only on the right side.
- Cam locks that are properly fastened on a horizontal board will face toward the center of the unit, on a vertical board the point on the lock will face the bottom.
- Back panels provide stability and support. Use all the nails provided.
- When tapping nails into a board, be sure there are equal margins on all sides to square the unit.
- Units without the back panel installed may collapse.
- Clean the product with your favorite furniture polish and a soft cloth. DO NOT USE harsh chemicals or abrasive cleaners.
- Move your new furniture carefully, with two people lift and carry the unit to its new location.
- Never push, drag or scoot your furniture (especially on carpet).
- Your furniture can be disassembled and reassembled to move.
- Additional parts are available for a nominal fee.

NOTES UTILES

- Visitar nuestro website para mirar los videos cortos del montaje.
- Identificar, clasificar y contar las piezas antes de intentar el montaje.
- Llamar gratis a nuestro número de servicio si necesita ayuda con identificar las piezas.
- Las clavijas de compresión se taladrarán con un martillo.
- Las correderas sólo tienen las protrusiones en el lado derecho.
- Las cerraduras de leva que se atan propiamente en una tabla horizontal se puntan al centro de la unidad, y las en una tabla vertical se puntan al fondo.
- Los paneles traseros se mantienen la estabilidad. Usar todos los tornillos proporcionados.
- Al taladrar los tornillos en una tabla, asegurarse que hay márgenes iguales en todos los lados para cuadrar la unidad.
- Las unidades sin panel trasero pueden derrumbarse.
- Limpiar la unidad con su pulimento favorito de mueble y una tela suave. NO UTILIZAR productos con químicos duros o abrasivos.
- Mover su mueble nuevo cuidadosamente, con dos personas levantar la unidad a su nuevo lugar.
- Nunca empujar o arrastrar su mueble (especialmente en alfombra).
- Poderse desmontar y volver a montar su mueble de para mover.
- Piezas adicionales están disponibles para una cuota nominal.

CONSEILS UTILES

- Visitez notre site Web pour visionner des vidéos d'assemblage.
- Identifiez, triez et comptez les pièces avant d'entreprendre l'assemblage.
- Appelez notre numéro sans frais si vous avez besoin d'aide pour identifier les pièces.
- Les goujons de compression sont enfoncés en frappant avec un marteau.
- Les glissières ont un rebord sur le côté droit seulement.
- Les serrures de came qui sont fixées correctement sur un panneau horizontal seront orientées vers le centre du meuble, sur un panneau vertical, la pointe de la serrure sera orientée vers le bas.
- Les panneaux arrière assurent la stabilité et le soutien. Utilisez tous les clous fournis.
- Lorsque vous frappez les clous dans le panneau, assurez-vous qu'ils sont à distance égale sur tous les côtés pour bien cadrer le meuble.
- Les meubles sans panneau arrière installé peuvent s'effondrer.
- Nettoyez le meuble avant votre poli à meubles préféré et un chiffon doux. NE PAS UTILISER de produits chimiques forts ou de nettoyeurs abrasifs.
- Déplacez délicatement votre nouveau meuble, avec deux personnes pour soulever et transporter le meuble à son nouvel emplacement.
- Ne jamais pousser, traîner ou tirer votre meuble (surtout sur un tapis).
- Votre meuble peut être démonté et réassemblé pour le déplacer.
- Des pièces supplémentaires sont disponibles pour un prix modique.

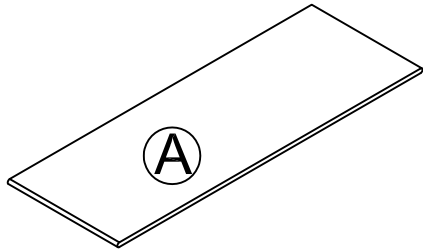

Top shelf  
Estante superior  
Étagère supérieure

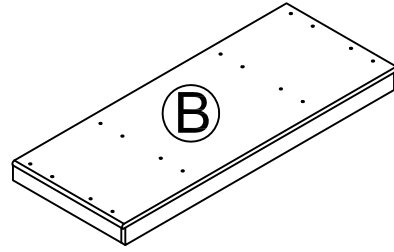

Bottom frame  
Marco inferior  
Cadre inférieur

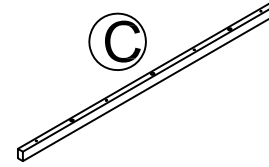

Top shelf apron  
Embellecedor para estante superior  
Ceinture étagère supérieure

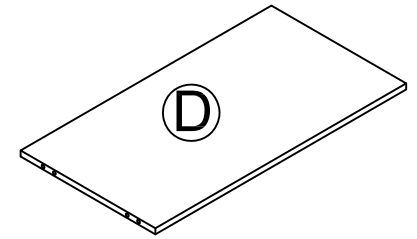

Center fixed shelf  
Estante fijo central  
Tablette centrale fixe

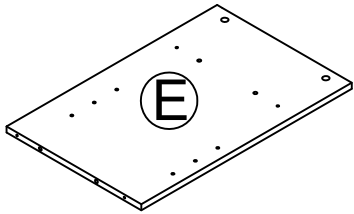

Left side panel  
Panel izquierdo  
Panneau gauche

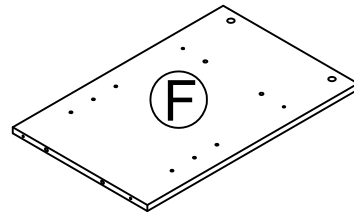

Right side panel  
Panel derecho  
Panneau droit

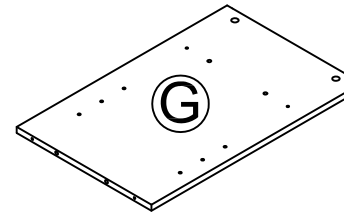

Left partition  
Partición izquierda  
Cloison gauche

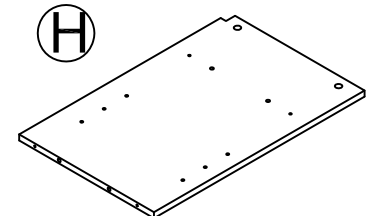

Right partition  
Partición derecha  
Cloison droite

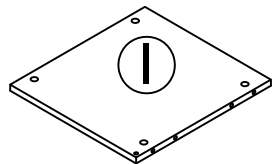

Left fixed shelf  
Estante fijo izquierdo  
Tablette gauche fixe

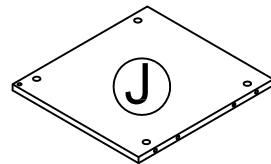

Right fixed shelf  
Estante fijo derecho  
Tablette droite fixe

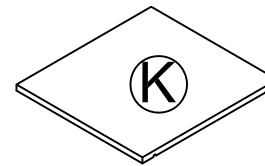

Adjustable shelf (2)  
Tablero ajustable (2)  
Tablette réglable (2)

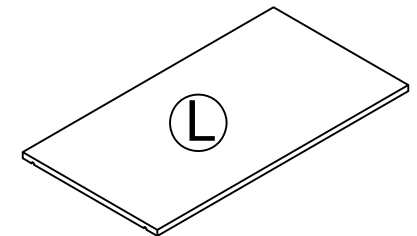

Center adjustable shelf  
Estante central ajustable  
Tablette centrale réglable

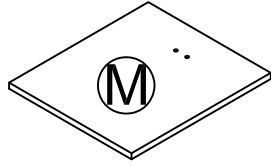

Left door  
Puerta izquierda  
Porte gauche

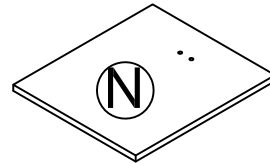

Left center door  
Puerta central izquierda  
Porte centrale gauche

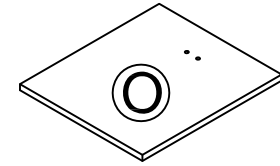

Right center door  
Puerta central derecha  
Porte centrale droite

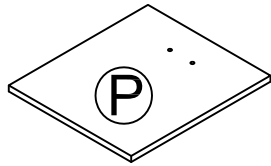

Right door  
Puerta derecha  
Porte droite

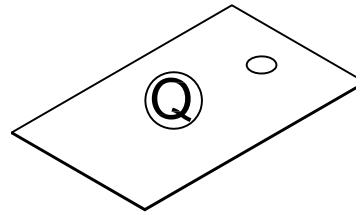

Back panel (2)  
Panel trasero (2)  
Panneau arrière (2)

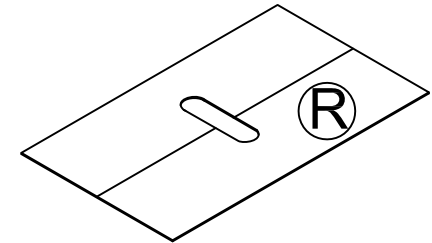

Back panel  
Panel trasero  
Panneau arrière

PARTS -PIEZAS - PIÈCES



Ø6 x 35 mm

1

x 20

Cam bolt  
Perno de la leva  
Boulon de came  
TWQ0001



Ø15 x 11 mm

2

x 20

Cam lock  
Cerradura de la leva  
Serrure de came  
TWQ0002



Ø8 x 30 mm

3

x 31

Wooden dowel  
Clavija de madera  
Goujon en bois  
TWQ0003



Ø3 x 15 mm

4

x 30

Screw  
Tornillo  
Vis  
TWQ0004



Ø4 x 44mm

5

x 8

Screw  
Tornillo  
Vis  
TWQ0082

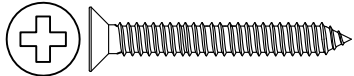

Ø4 x 32 mm

6

x 4

Screw  
Tornillo  
Vis  
TWQ0005

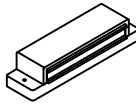

7

x 2

Magic catch  
Pestillo mágico  
Loquet magique  
TWQ0065



8

x 1

Glue  
Pegamento  
Colle  
TWQ0008

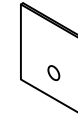

30 x 22 x1

9

x 4

Magic catch plate  
Placa de pestillo mágico  
Plaque de loquet magique  
TWQ0064

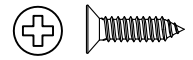

Ø3 x 15 mm

10

x 10

Screw  
Tornillo  
Vis  
TWQ0101

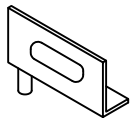

40\*16.5\*15

11

x 4

Hinge  
Bisagra  
Charnière  
TWQ0056

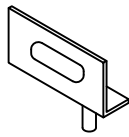

40\*16.5\*15

12

x 4

Hinge  
Bisagra  
Charnière  
TWQ0057



Ø8x12D9

13

x 8

Door shaft support  
Soporte para eje de puerta  
Support de tige de porte  
TWQ0040



Ø9x4x12mm

14

x 2

Screw bolt  
Tornillo con tuerca  
Vis à boulon  
TWQ0061

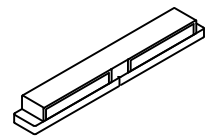

15

x 1

Magic catch  
Pestillo mágico  
Loquet magique  
TWQ0084

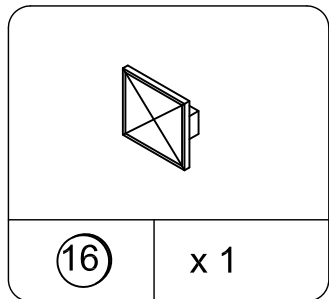

16 x 1

Knob  
Puno  
Bouton  
TWQ0085

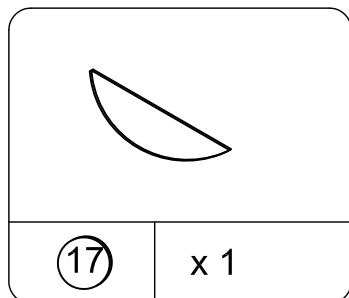

17 x 1

Pull  
Jalón  
Poignée  
TWQ0031

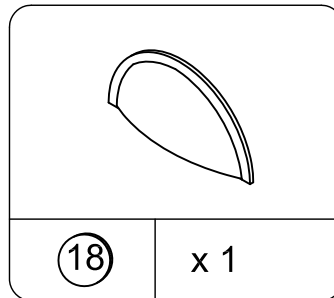

18 x 1

Pull  
Jalón  
Poignée  
TWQ0090

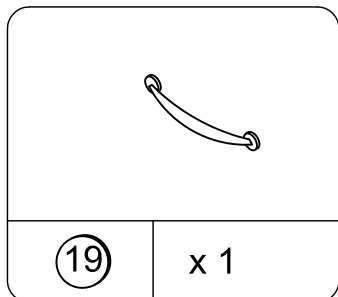

19 x 1

Handle  
Manija  
Poignée  
TWQ0042

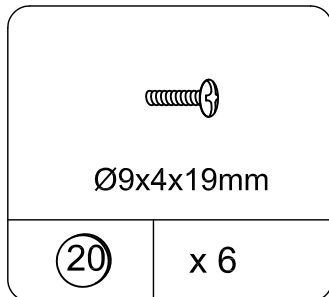

20 x 6

Screw bolt  
Tornillo con tuerca  
Vis à boulo  
TWQ0060

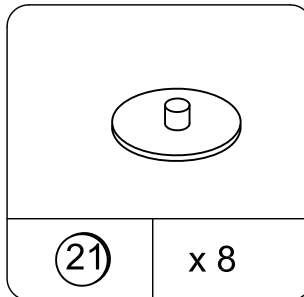

21 x 8

Cam cover  
Leva de cubierta  
Cache-Came  
TWQ0062

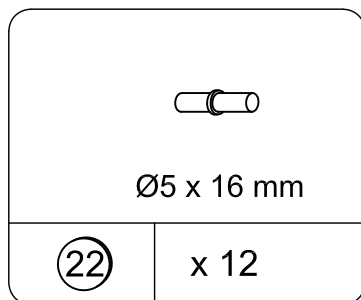

Ø5 x 16 mm

22 x 12

Shelf pin  
Pasador para el Tablero  
Taquet  
TWQ0018

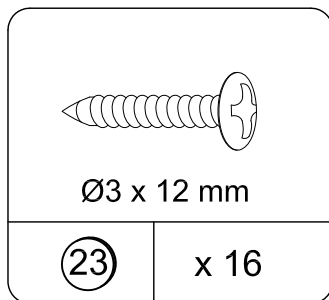

Ø3 x 12 mm

23 x 16

Screw  
Tornillo  
Vis  
TWQ0103

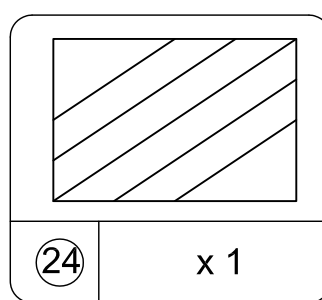

24 x 1

Warning label  
Etiqueta de Advertencia  
Étiquette d'avertissement  
TWQ0114

This illustration shows how the CAM fastening system works.  
Esta ilustración muestra como funciona el sistema de fijación de leva.

Cette illustration montre comment le système de fixation de la CAME fonctionne

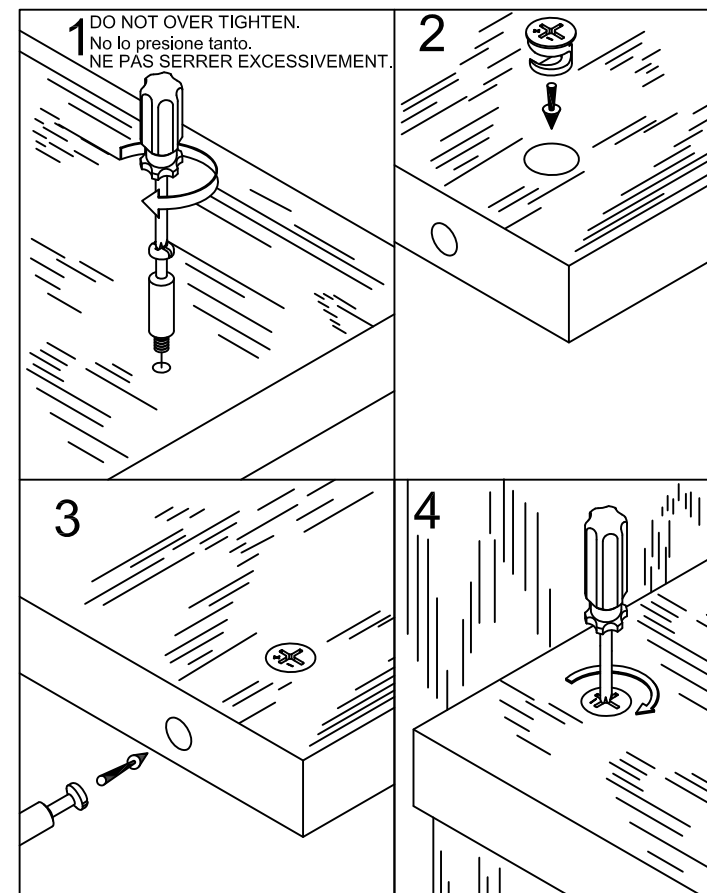

# 1

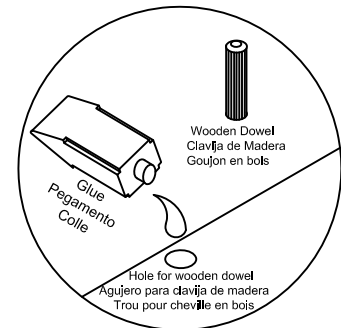
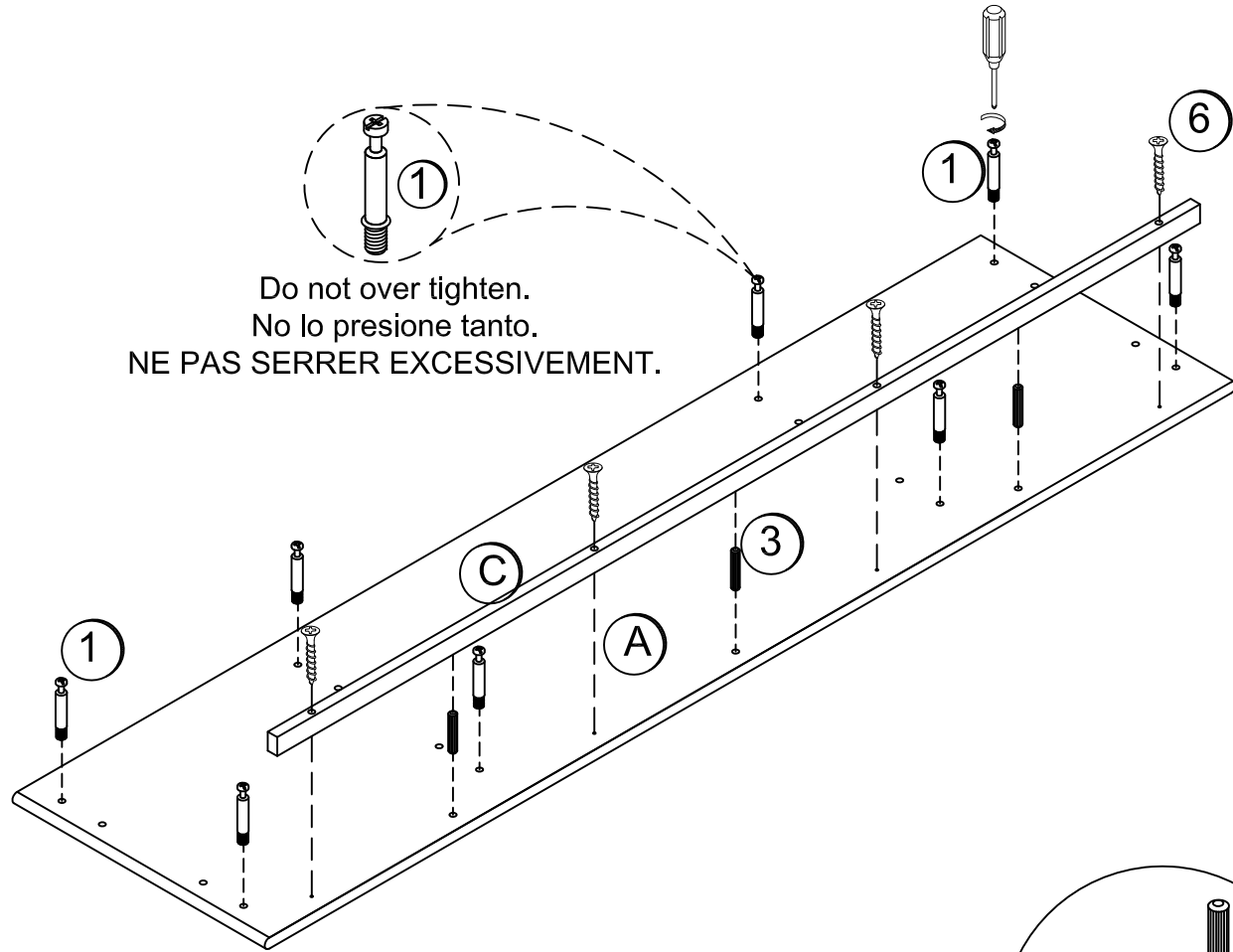
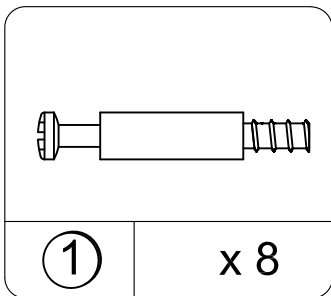
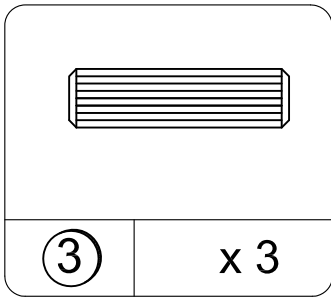
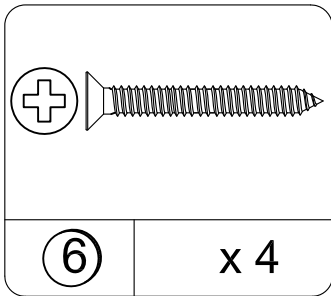

Use one drop of glue in dowel hole.  
Use una gota de pegamento en el agujero de clavija.  
Utilisez une goutte de colle dans le trou de la cheville

# 2

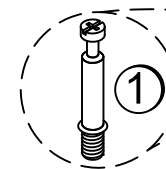
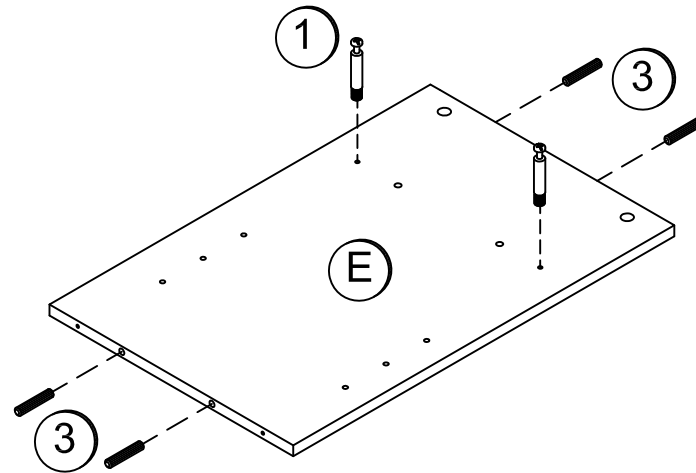

Do not over tighten.  
No lo presione tanto.  
NE PAS SERRER EXCESSIVEMENT.

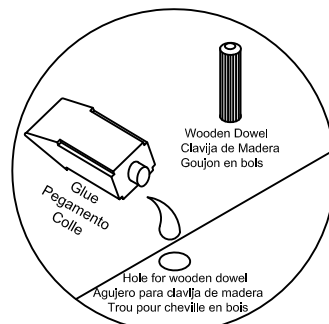
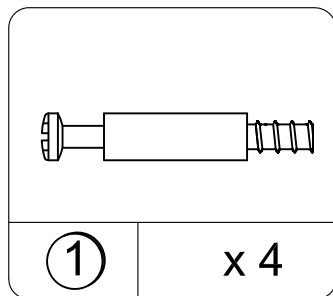
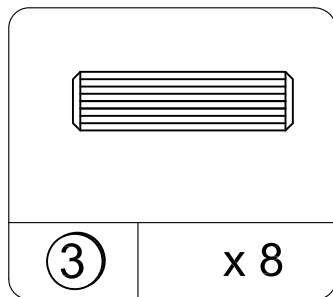
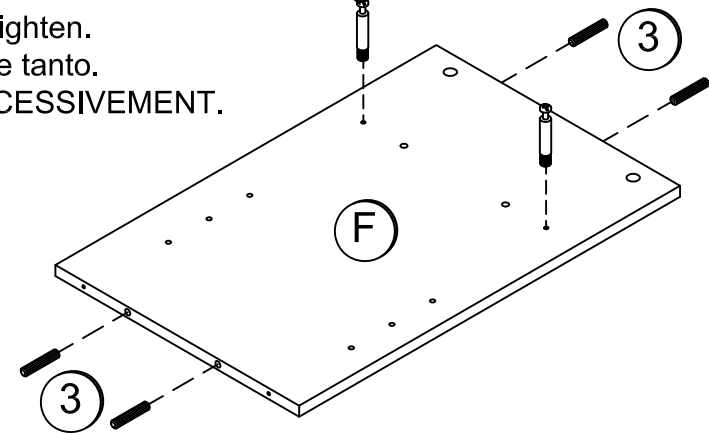

Use one drop of glue in dowel hole.  
Use una gota de pegamento en el agujero de clavija.  
Utilisez une goutte de colle dans le trou de la cheville

# 3

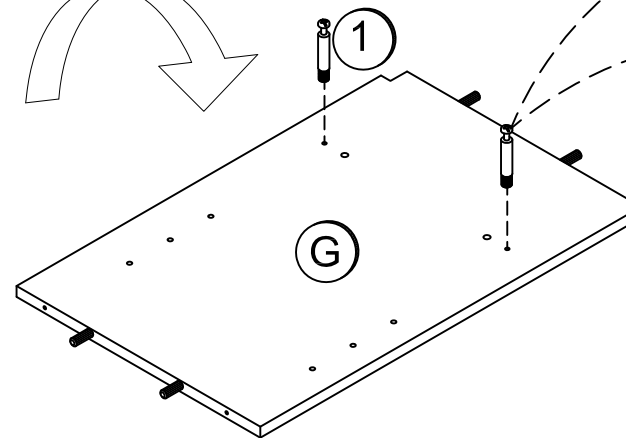
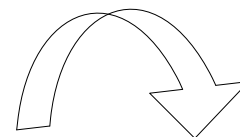
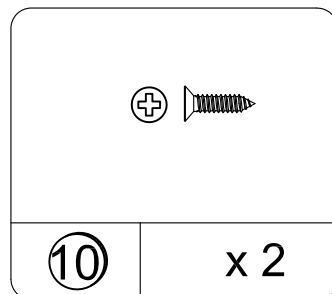
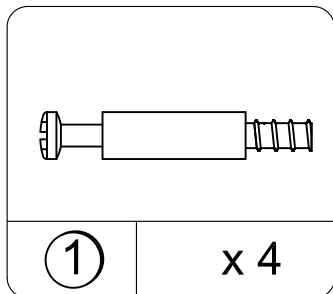
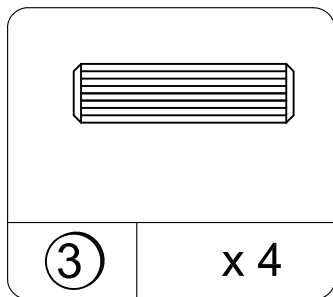
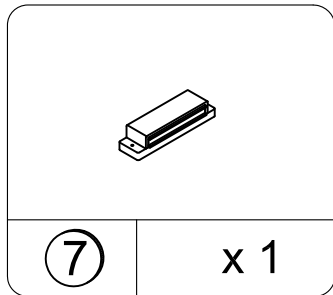
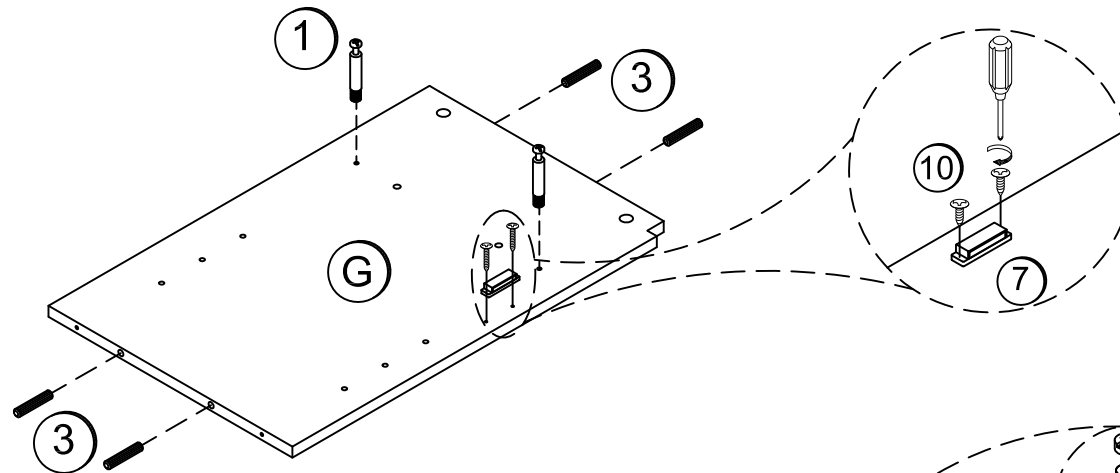

Do not over tighten.  
No lo presione tanto.  
**NE PAS SERRER EXCESSIVEMENT.**

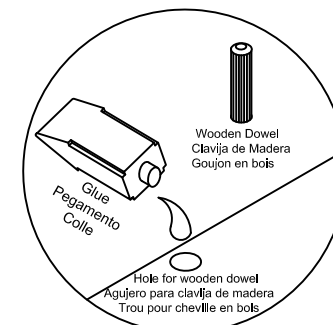

Use one drop of glue in dowel hole.  
Use una gota de pegamento en el agujero de clavija.  
Utilisez une goutte de colle dans le trou de la cheville

# 4

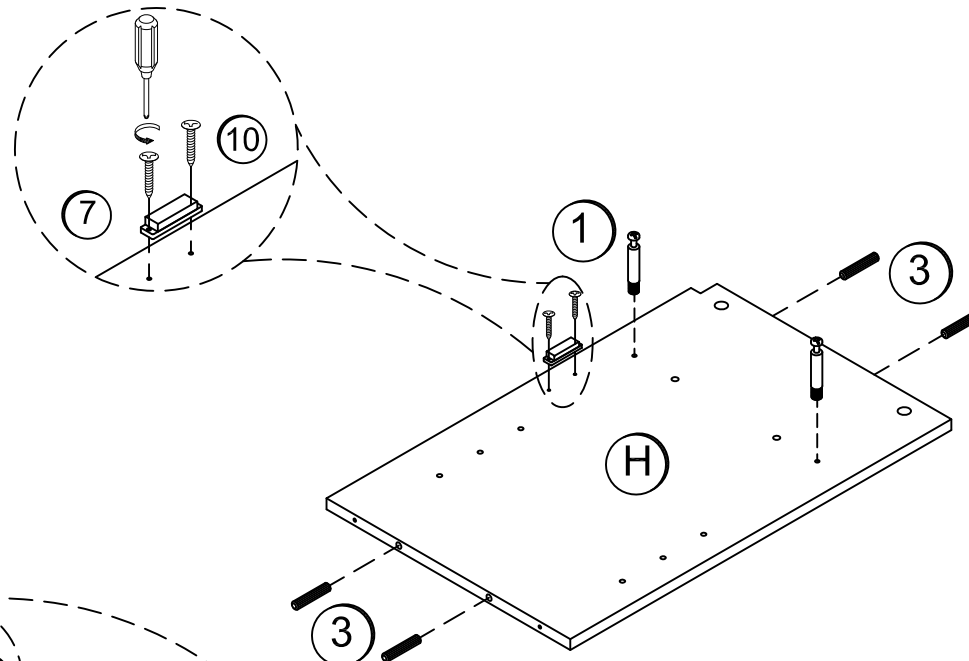
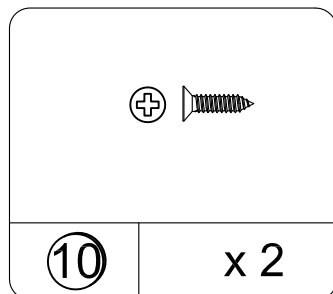
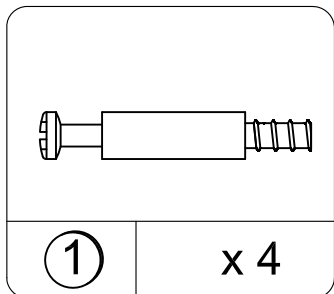
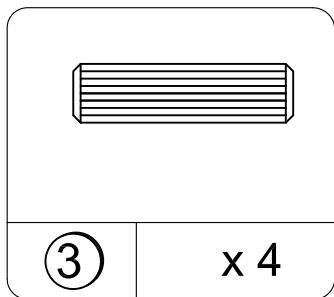
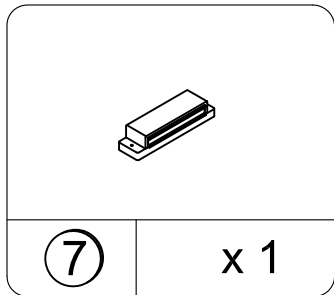

Do not over tighten.  
No lo presione tanto.  
NE PAS SERRER EXCESSIVEMENT.

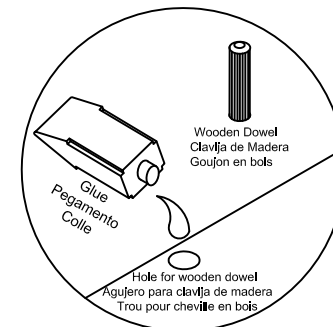
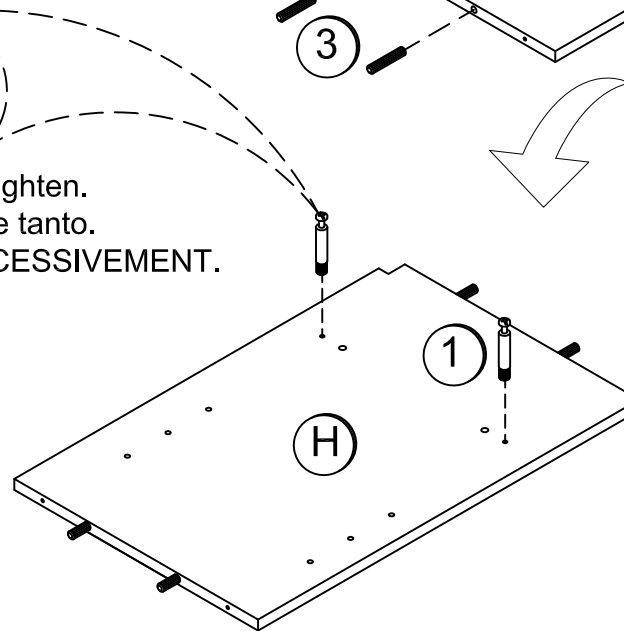

Use one drop of glue in dowel hole.  
Use una gota de pegamento en el agujero de clavija.  
Utilisez une goutte de colle dans le trou de la cheville

# 5

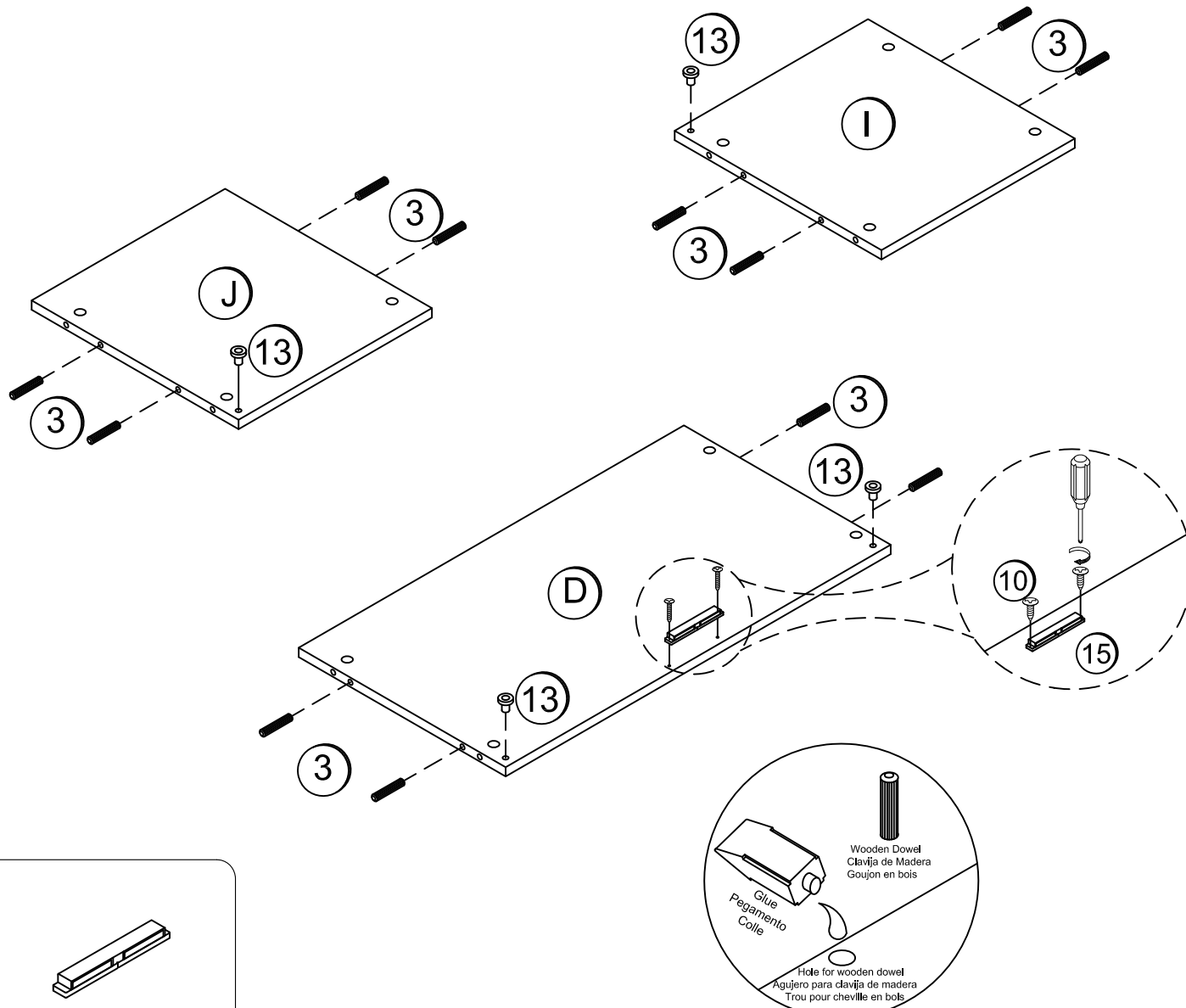
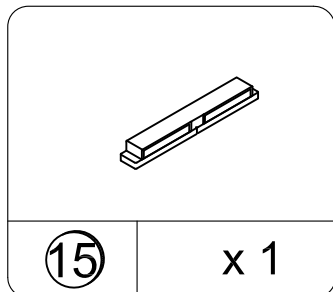
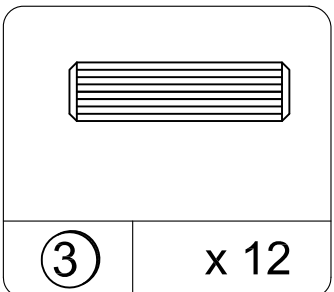
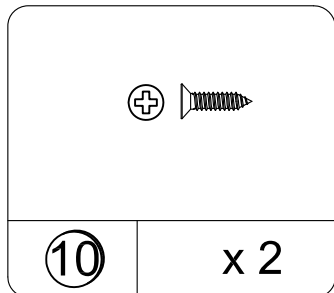
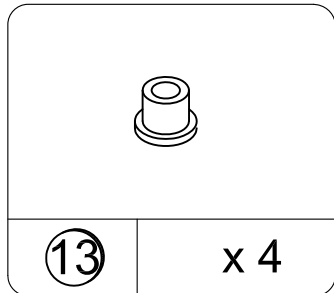

Use one drop of glue in dowel hole.  
 Use una gota de pegamento en el agujero de clavija.  
 Utilisez une goutte de colle dans le trou de la cheville



# 7

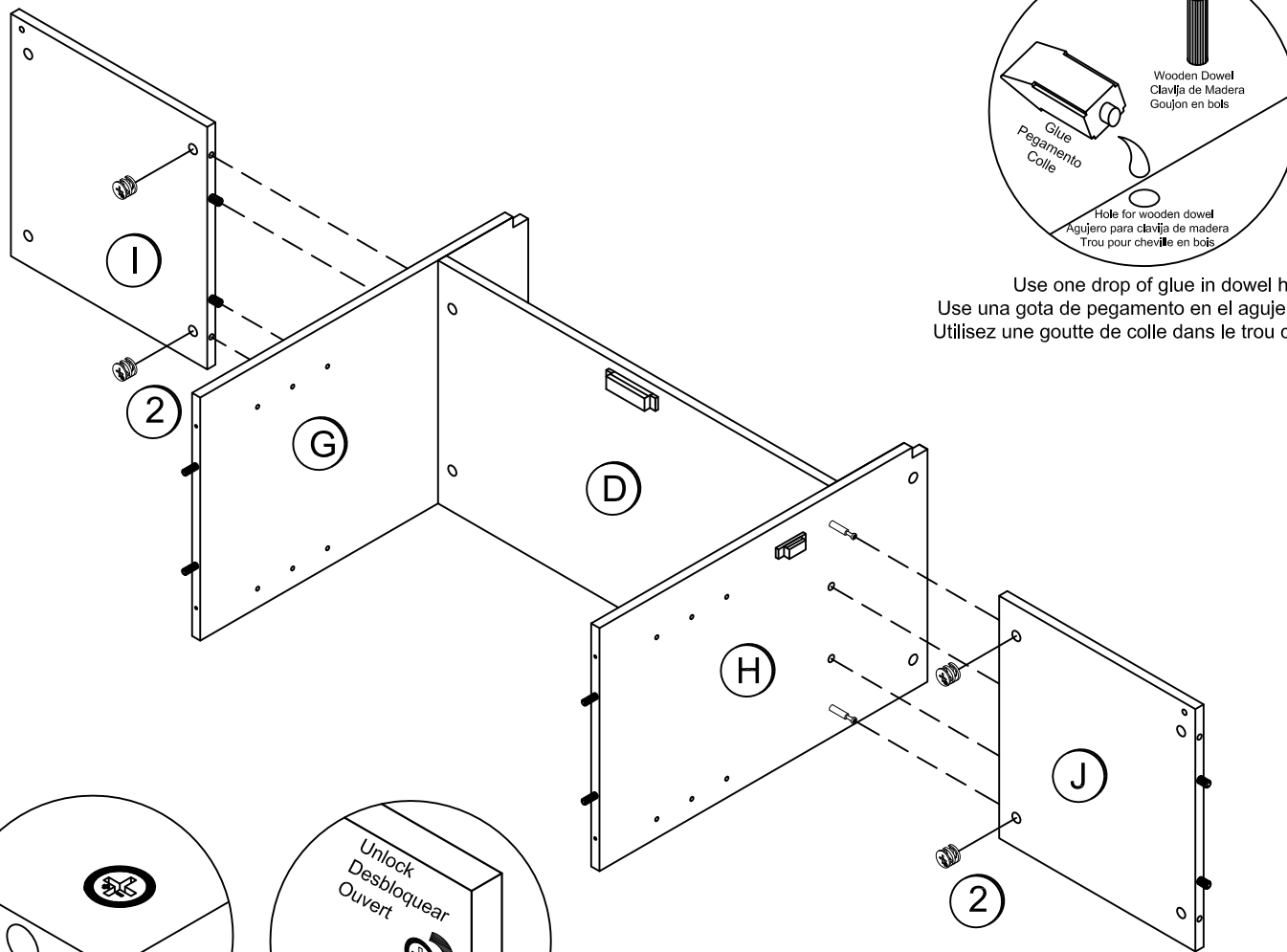

Use one drop of glue in dowel hole.  
 Use una gota de pegamento en el agujero de clavija.  
 Utilisez une goutte de colle dans le trou de la cheville

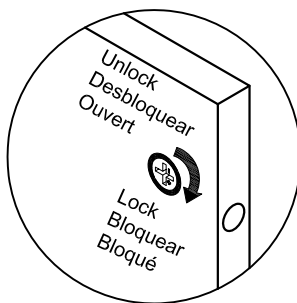
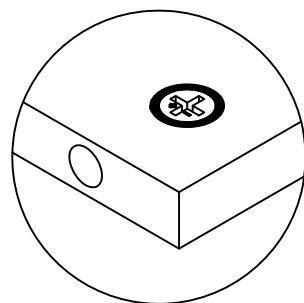
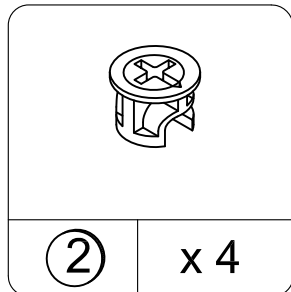

Proper orientation of cam lock  
 La orientación apropiada para el seguro de bloqueo  
 Bonne orientation du dispositif de blocage à came

# 8

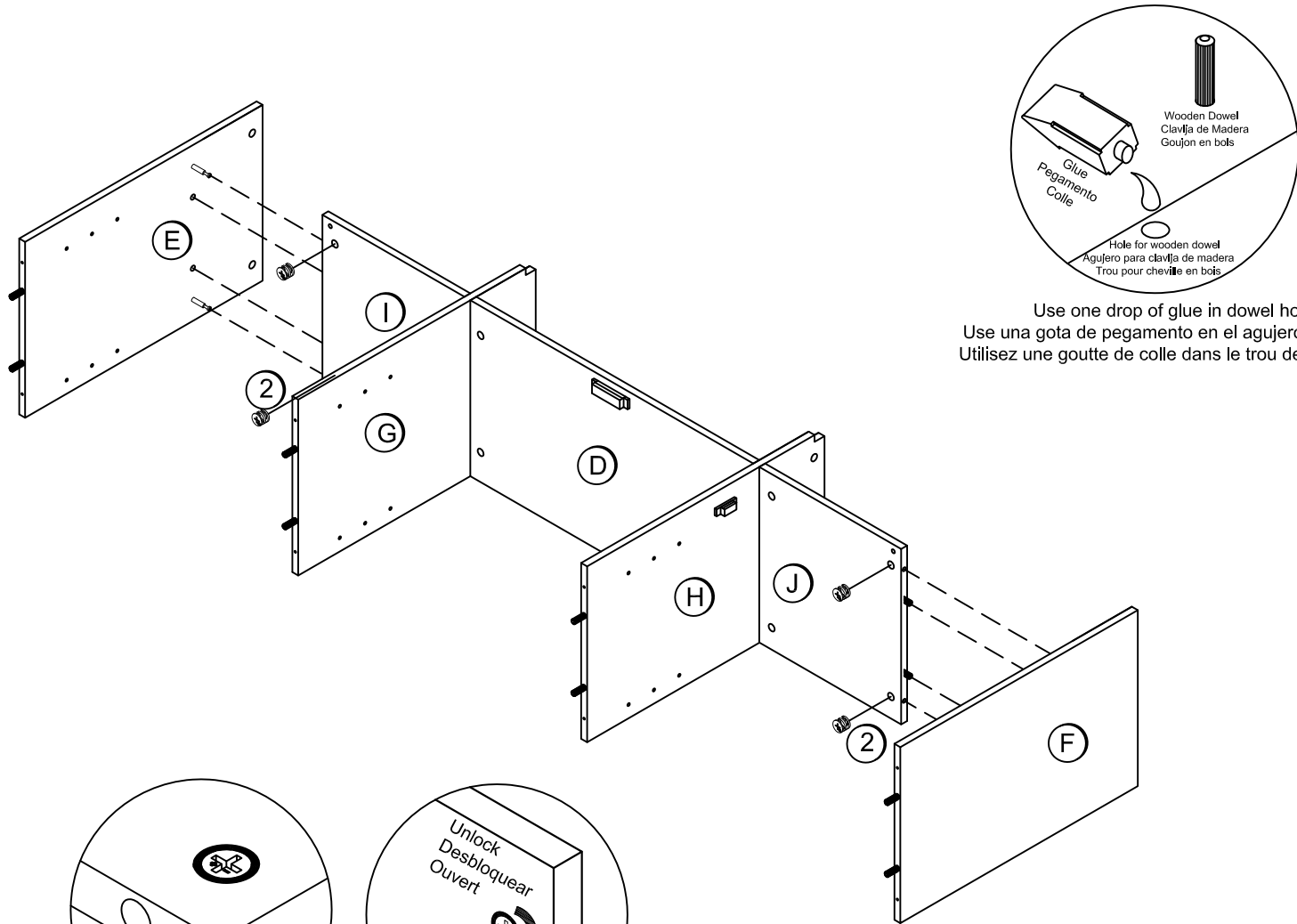

Use one drop of glue in dowel hole.  
 Use una gota de pegamento en el agujero de clavija.  
 Utilisez une goutte de colle dans le trou de la cheville

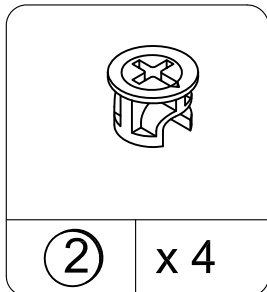

Proper orientation of cam lock  
 La orientacion apropiada para el seguro de bloqueo  
 Bonne orientation du dispositif de blocage à came

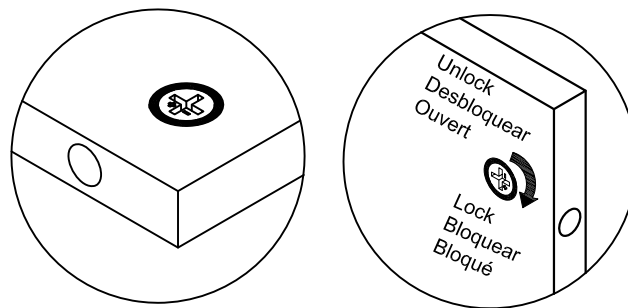

# 9

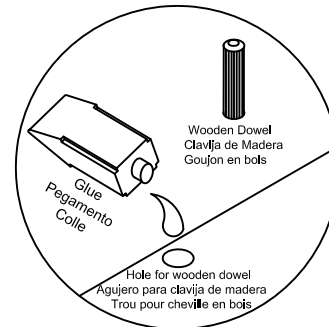
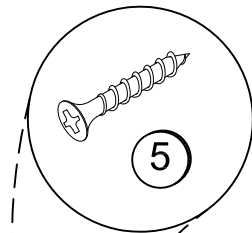

Use one drop of glue in dowel hole.  
Use una gota de pegamento en el agujero de clavija.  
Utilisez une goutte de colle dans le trou de la cheville

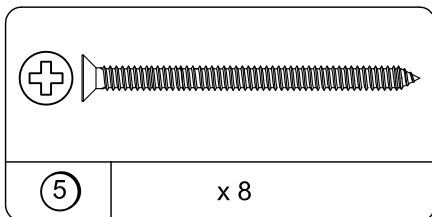
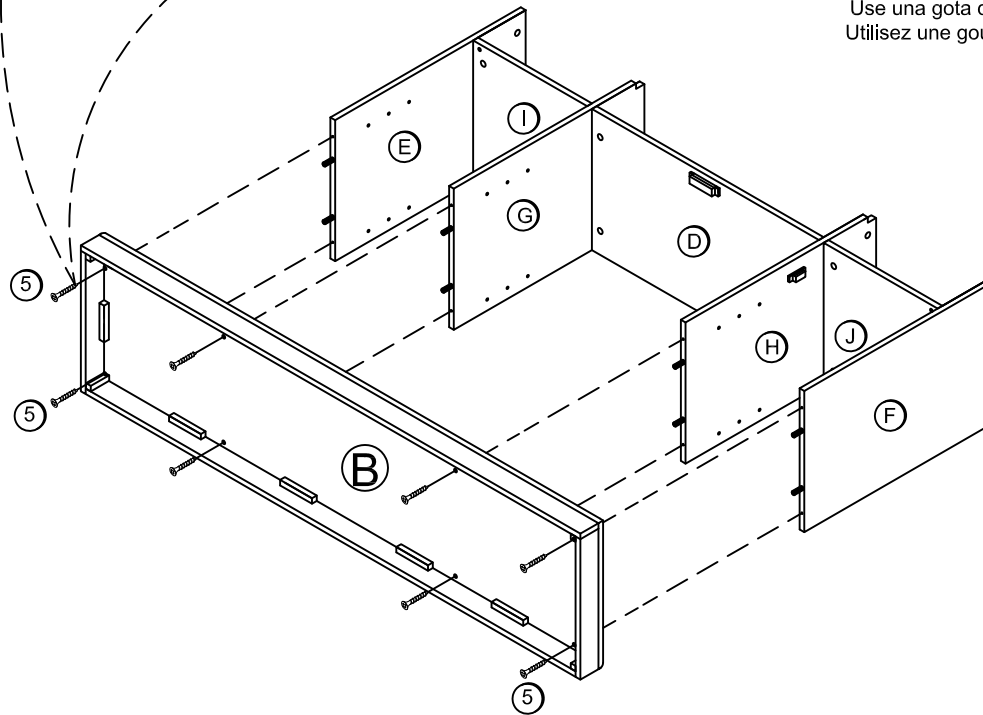

# 10

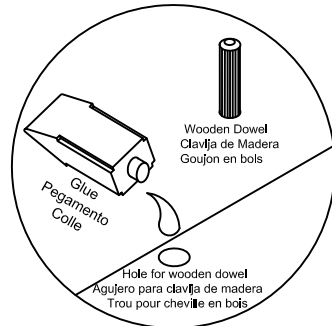

Use one drop of glue in dowel hole.  
 Use una gota de pegamento en el agujero de clavija.  
 Utilisez une goutte de colle dans le trou de la cheville

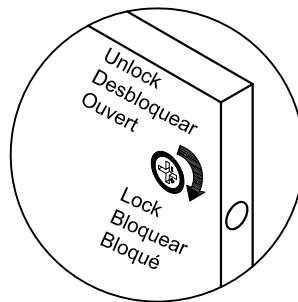
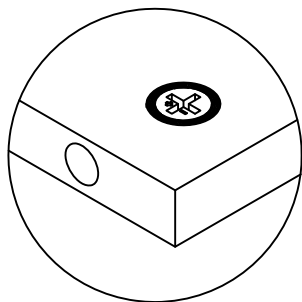
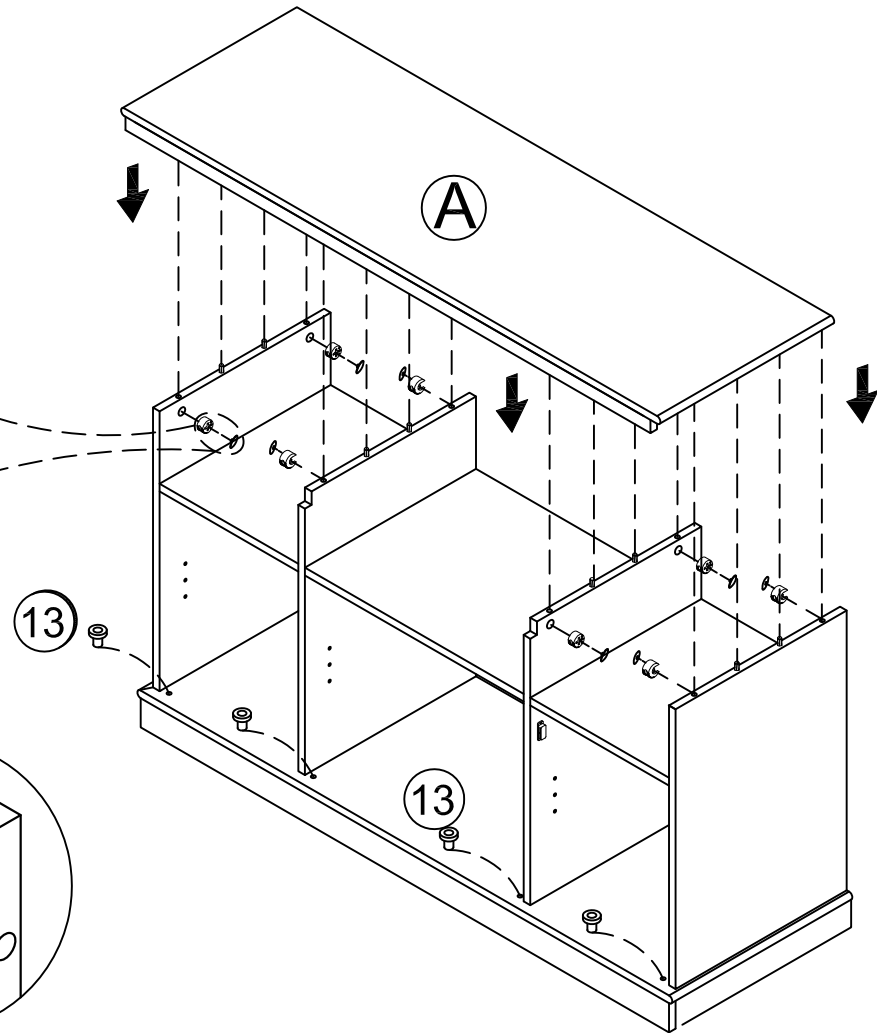
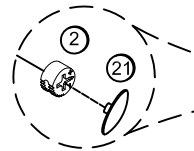
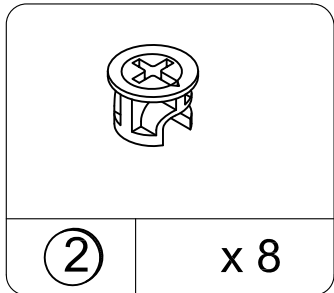
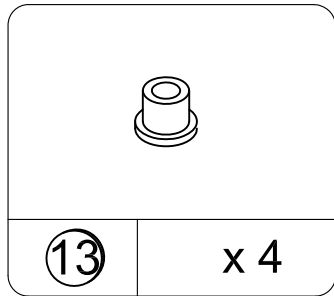
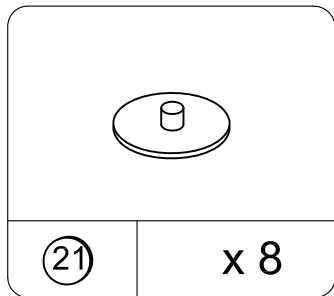

Proper orientation of cam lock  
 La orientación apropiada para el seguro de bloqueo  
 Bonne orientation du dispositif de blocage à came

# 11

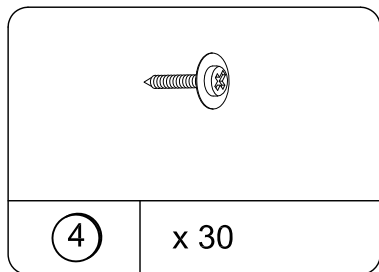
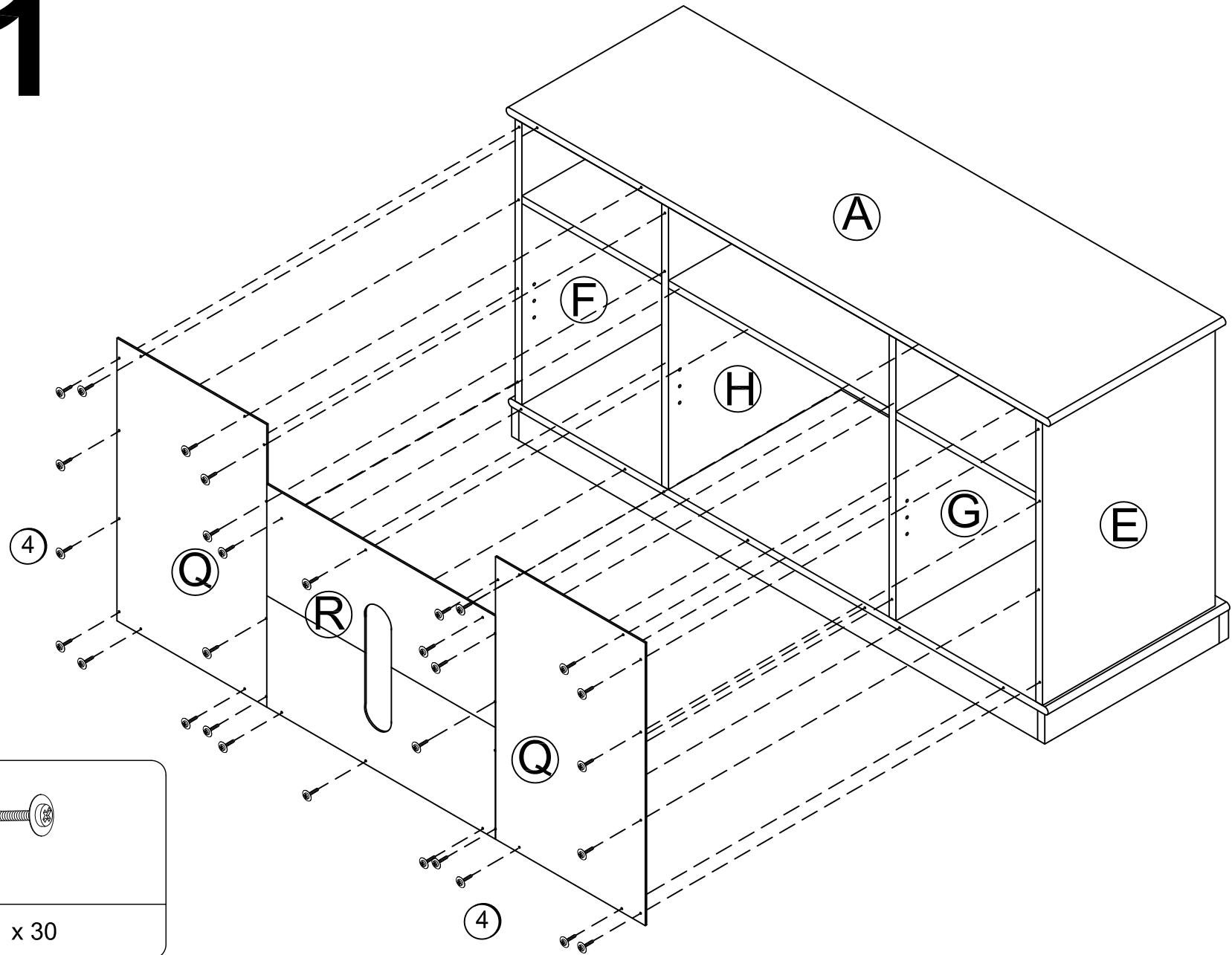

# 12

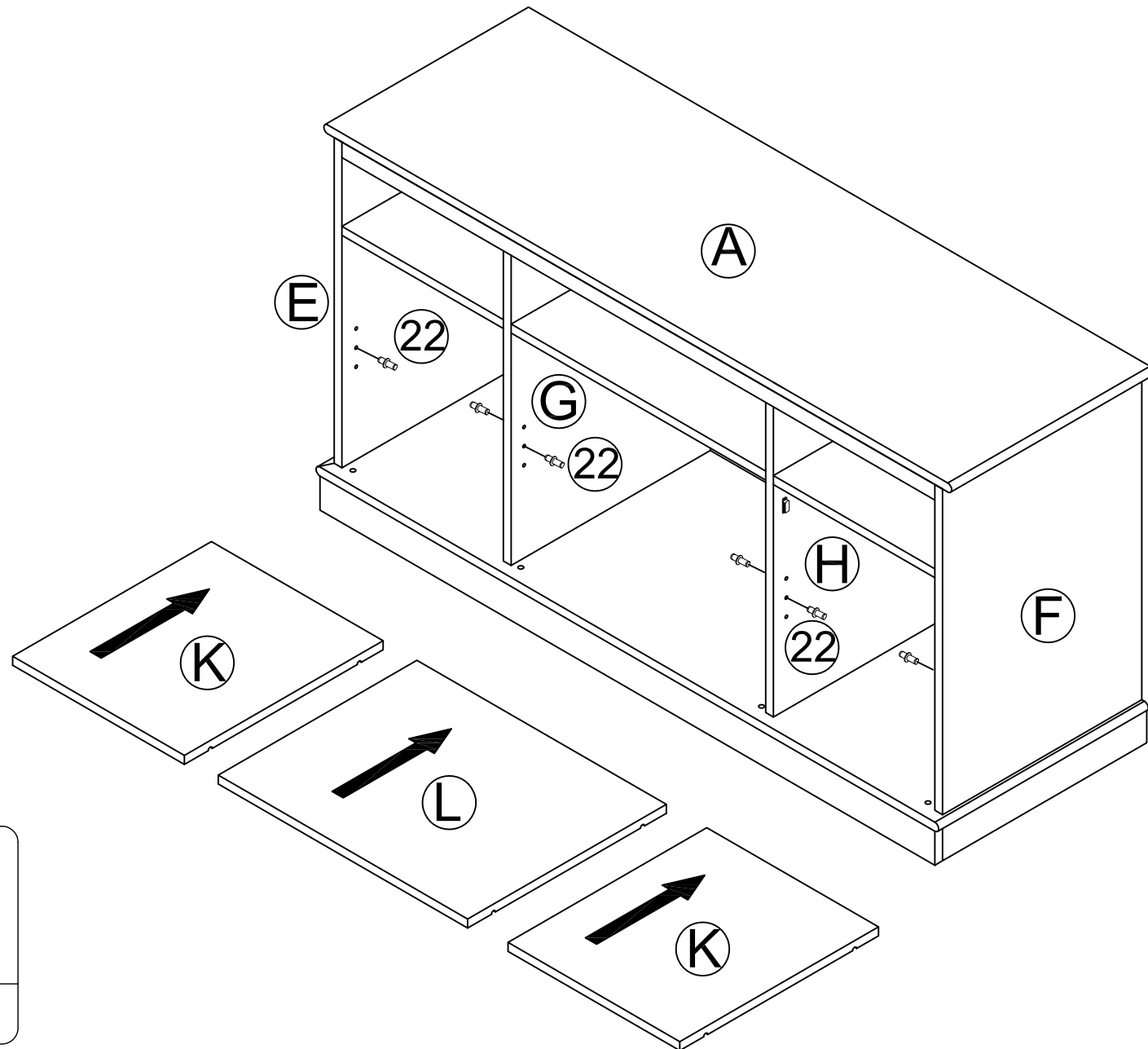

# 13

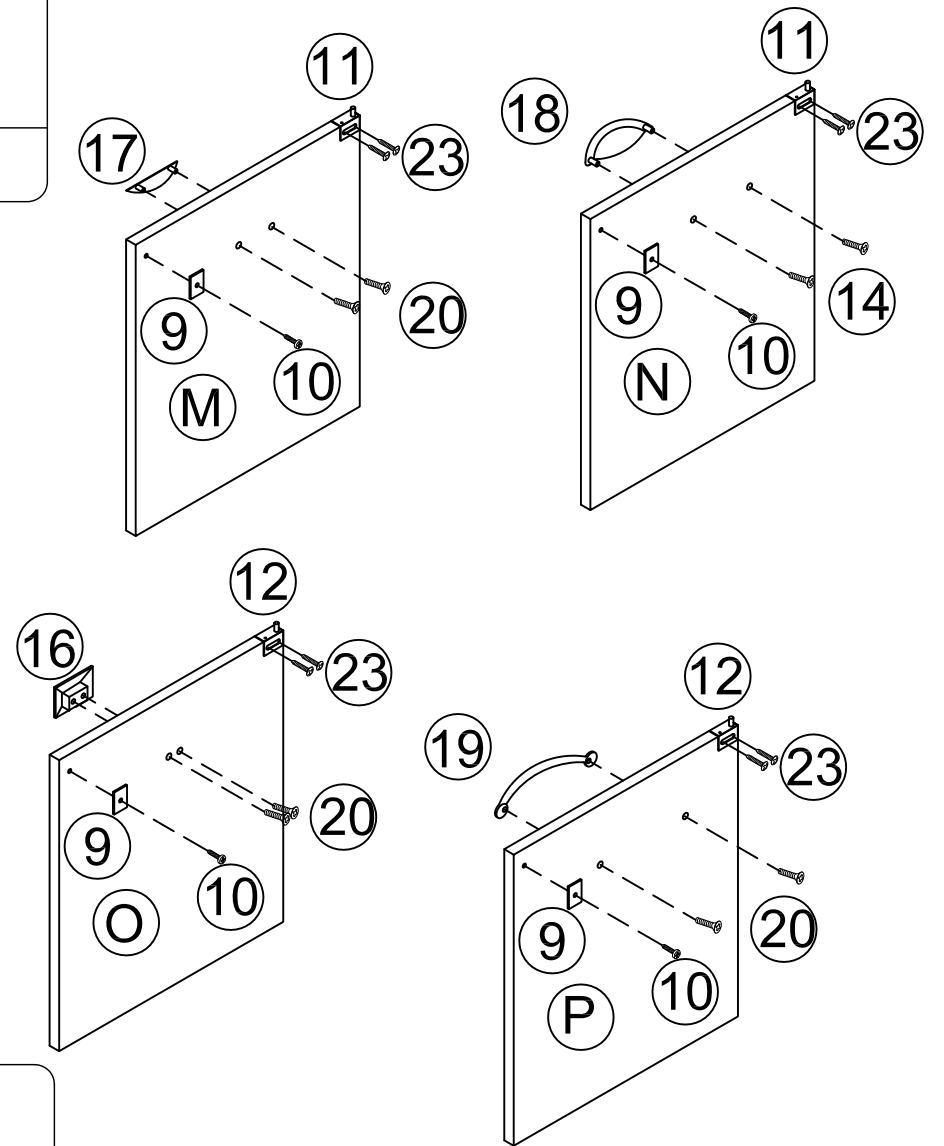
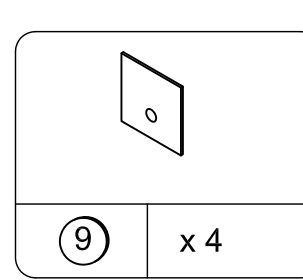
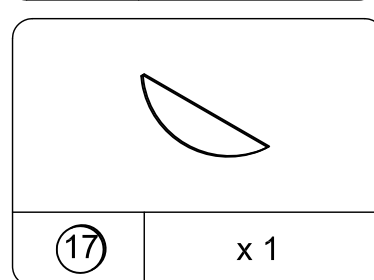
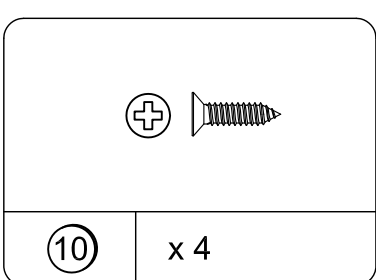
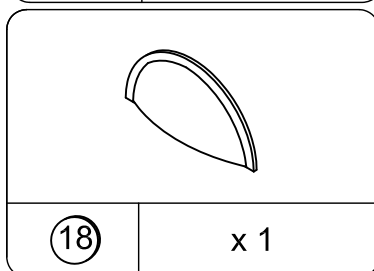
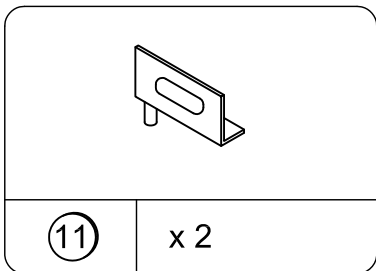
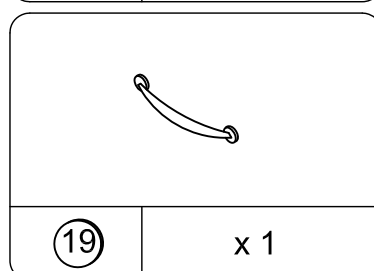
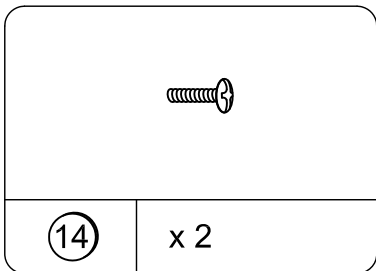
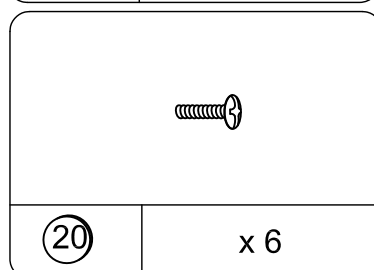
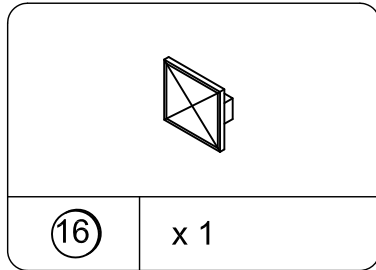
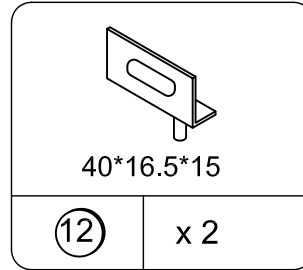
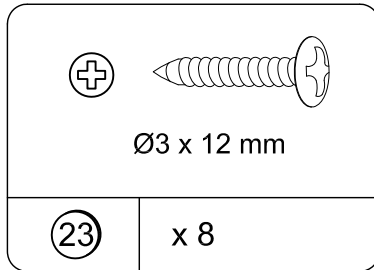

# 14

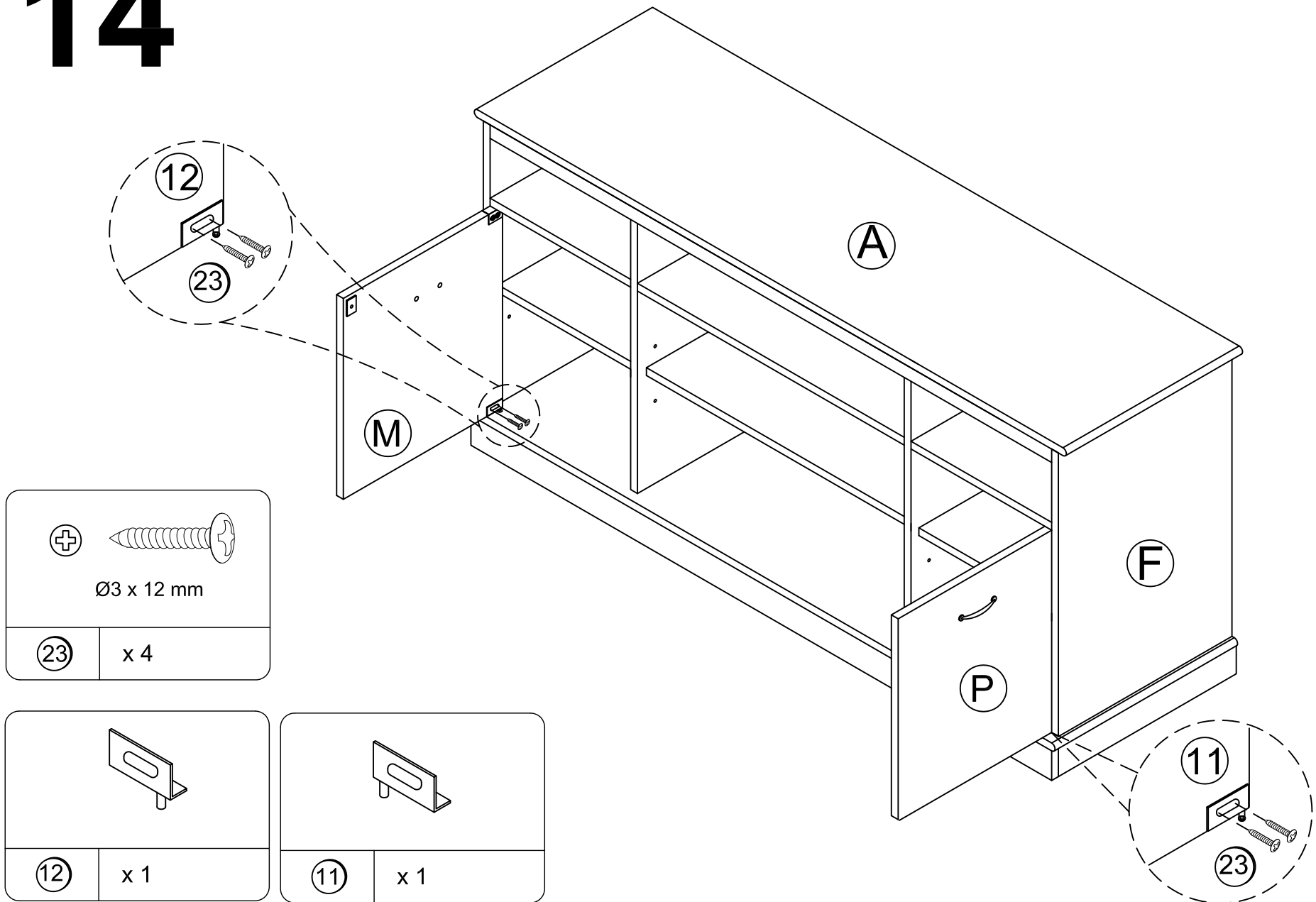

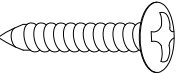
	
Ø3 x 12 mm	
<b>23</b>	x 4

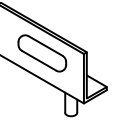
	
<b>12</b>	x 1

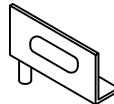
	
<b>11</b>	x 1

# 15

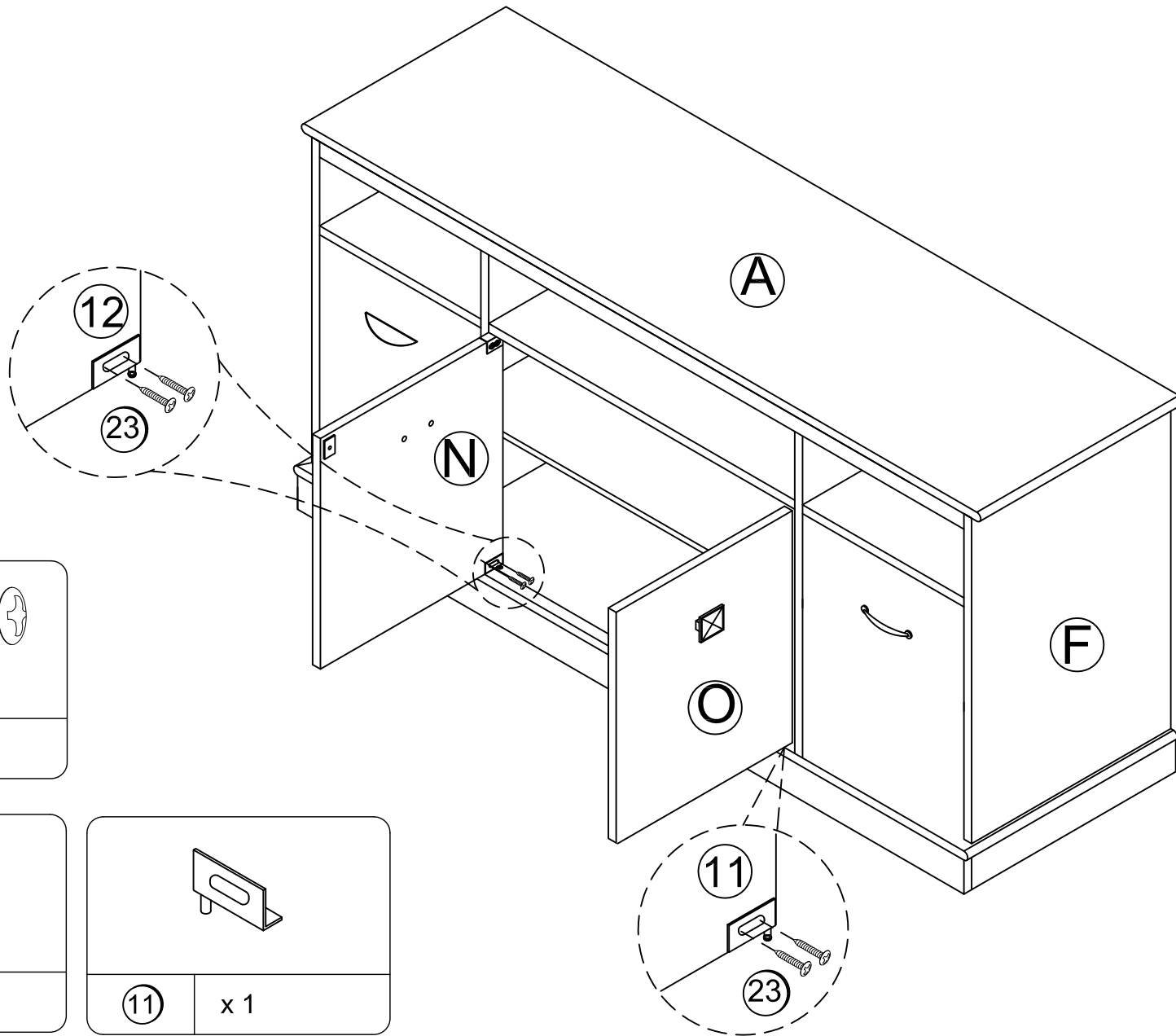

WEIGHT LIMITS:  
LÍMITES DE PESO:  
LIMITES DE POIDS:

This unit has been designed to support the maximum loads shown. Exceeding these load limits could cause sagging, instability, product collapse, and/or serious injury.

Esta unidad se ha diseñado para apoyar las cargas máximas mostradas. Exceder estos límites de carga podría causar ceder, inestabilidad, derrumbamiento del producto, o lesión seria.

Ce meuble a été conçu pour supporter les charges maximales indiquées. Le dépassement de ces limites de poids peut causer l'affaissement, l'instabilité, l'effondrement du produit, et/ou des blessures graves.

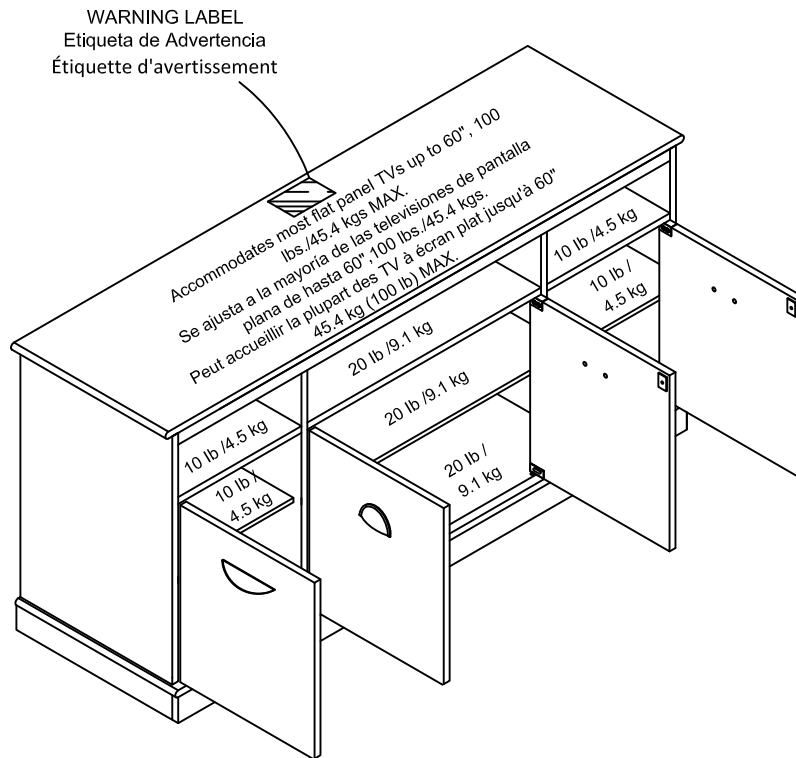

Enjoy Your Furniture  
Disfrute de su mueble  
Profitez de votre mobilier

**⚠ WARNING**

Please make sure that all objects are removed before moving the assembled unit.

The unit must be team lifted, not dragged or pushed.

Failure to do so could cause instability, product collapse, and/or serious injury.

**⚠ ADVERTENCIA**

Por favor mueva el mueble cuidadosamente con la ayuda de otra persona. Levante y mueva el mueble a su lugar. No lo arrastre o empuje, de lo contrario puede haber inestabilidad en el mueble y esto puede colapsar u ocasionar graves lesiones.

**⚠ AVERTISSEMENT**

Veillez enlever tous les objets avant de déplacer le meuble. Le meuble doit être soulevé en équipe, et non traîné ou poussé. Le non respect de cet avertissement peut provoquer l'instabilité, l'effondrement du produit, et/ou des blessures graves.