

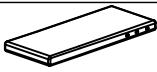











Assembly Instructions

Parts Lists

Tools Lists

Product name:	Sofa 023/60CM
---------------	---------------

NO.	Name	Parts drawing	Parts size	Quantity
1	Seat cushion soft package		1860*600*130MM	1
2	Right Tripod		610*610*55MM	1
3	Left Tripod		610*610*55MM	1
4	Backrest cushion		562*280*140MM	1

NO.	Name	Parts drawing	Parts size	Quantity
A	Hexagon socket screws		M8*50MM	4
B	Flat gasket		M8*16MM	4
C	Hexagon socket screws		M6*19MM	8
D	Flat gasket		M6*16MM	8
E	Spring gasket		M6	8
F	Hexagonal Wrenches		M5*57MM	1
G	Hexagonal Wrenches		M4*57MM	1
H	L-Shaped Angle Yard		32*20*17MM	4
I	Cloth Pad		∅20*3mm	4

Note: The (installed) in the parts list and hardware list means installed in the finished product, not in the hardware package!!!!

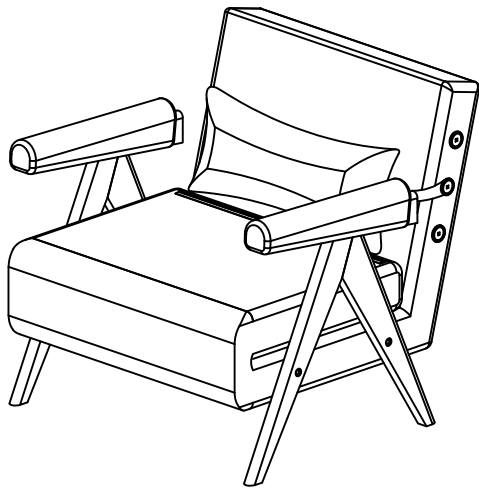

certificate of conformity	This product by the wood inspection, paint inspection in full compliance with national quality inspection standards, qualified to give the factory, to confirm that the packaging is intact for sale. In order to ensure our commitment, customers are welcome to provide valuable advice to our after-sales service	Product Name	solid wood furniture.	Number of installers		Quality inspector	QC 02	Page:1-3
		Qualified	Qualified products					
		Level	One Level					

Step1:

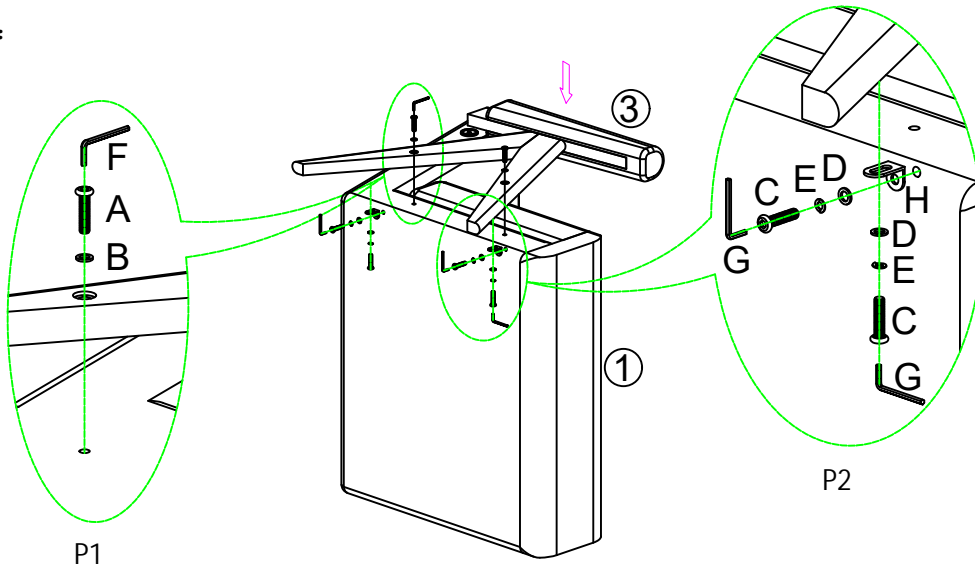

Note: After unpacking, please check with the instruction manual to see if the number of assembled parts is correct. As shown in the picture, firstly align the No.3 part with the hole of No.1 part, and then fix it with hardware A/B/F respectively. Then assemble and fix the No.1 / No.3 parts with hardware C, D, E, G, H as shown in Fig.2.

Step2:

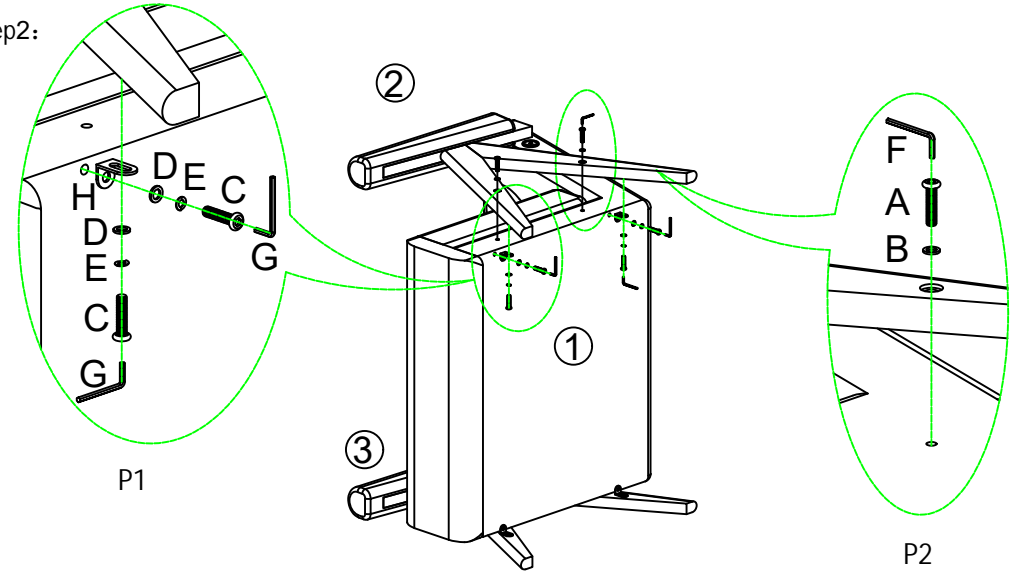

► Assemble as in Fig.1, first align the No.3 part with the hole of No.1 part, then fix it with hardware A/B/F respectively.
 ► Assemble as in Fig.2, first align the No.1 part with the holes, then fix it with hardware C, D, E, G, H respectively.

Step3:

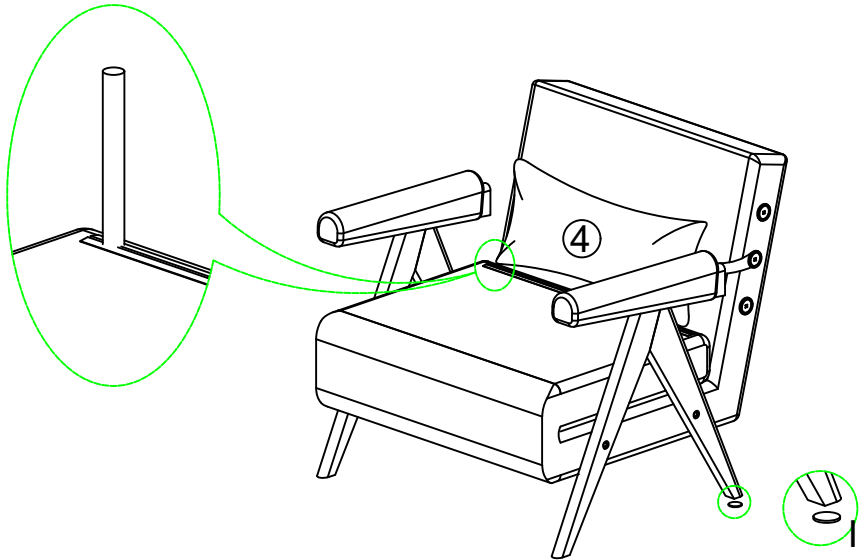

► As shown in the picture first open the zipper at the back position of the seat cushion, then open the internal hidden hardware foot post, please see the installation video for detailed tutorial!!!! Finally attach the hardware D to the bottom of the foot.

Step4:

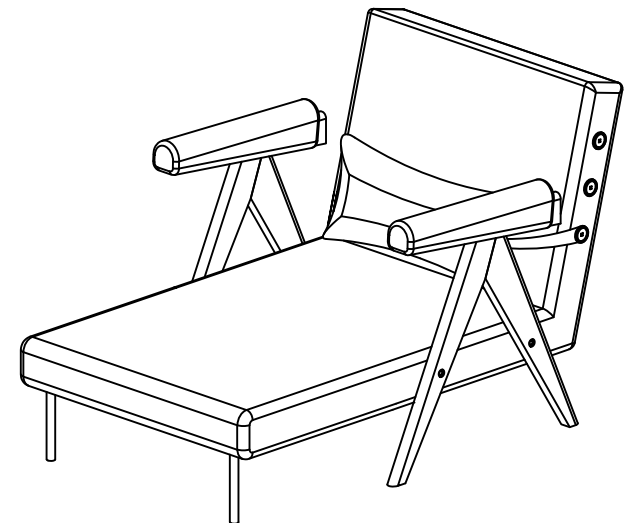

► Semi-expanded state!!!

Step5:

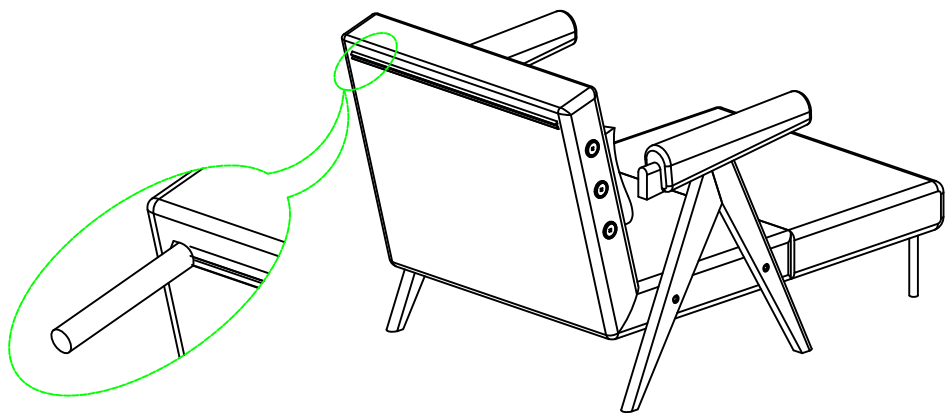

As shown in the picture first open the zipper at the backrest back position, then open the internal hidden hardware foot post, adjust the angle as needed for a detailed tutorial please see the installation video!!!!

Step6:

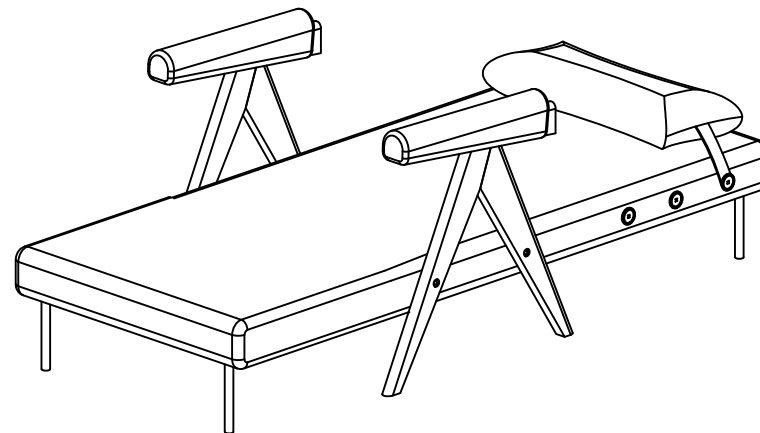

► All Expanded Status!!!

Step7:

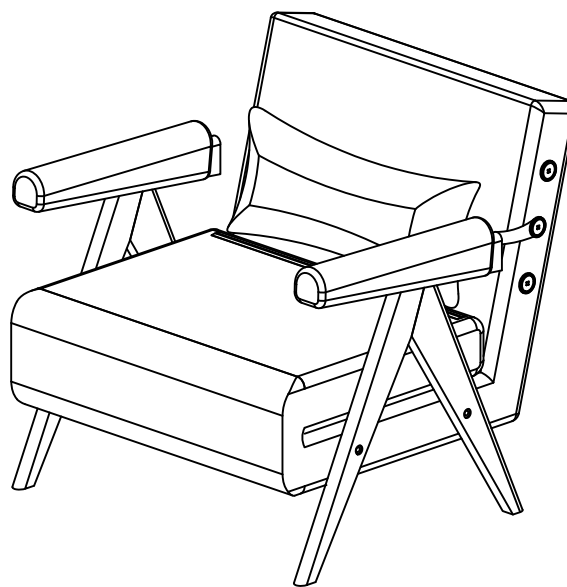

► Assembly is complete.