

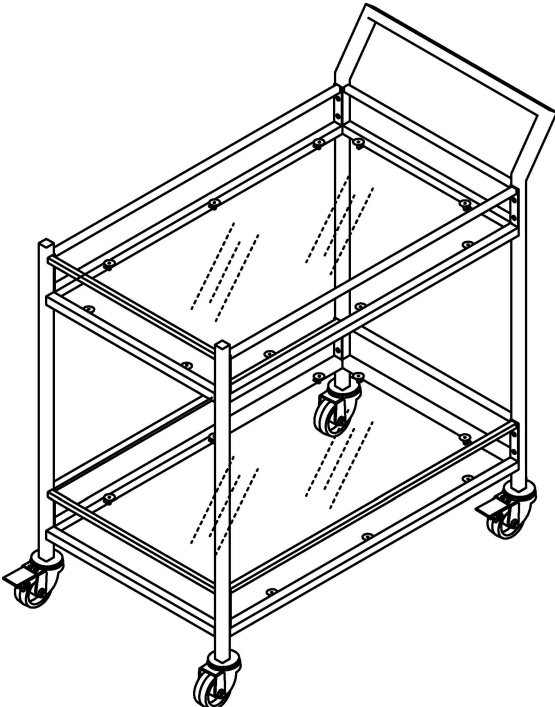

# Bar Cart

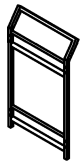
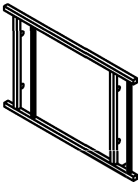
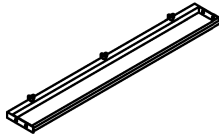
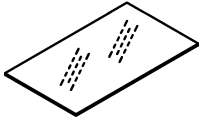
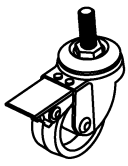

# PART LIST

<p><b>A</b></p> 	<p><b>B</b></p> 	<p><b>C</b></p> 	<p><b>D</b></p> 	<p><b>E</b></p> 
<p>Front Panel 1 PC</p>	<p>Back Panel 1 PC</p>	<p>Side Panel 4 PCS</p>	<p>Glass Shelf 2 PCS</p>	<p>Locking Caster 2 PCS</p>
<p><b>F</b></p> 				
<p>Caster 2 PCS</p>				

# HARDWARE LIST

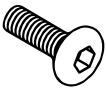
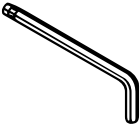
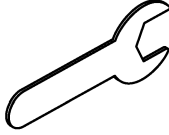
<p><b>#1</b></p>  <p>1/2"xØM6xD10</p>	<p><b>#2</b></p> 	<p><b>#3</b></p> 
<p>Bolt 16 PCS (Extra1)</p>	<p>Allen Wrench 1 PC</p>	<p>Wrench 1 PC</p>

Step 1. Lay back panel (part B) upside down on a soft surface, such as carpet, as show below. Attach side panels (part C) to back panel (part B) using bolts (part #1) and allen wrench (part #2). Attach front panel (part A) to side panels (part C) using bolts (part #1) and allen wrench (part #2).

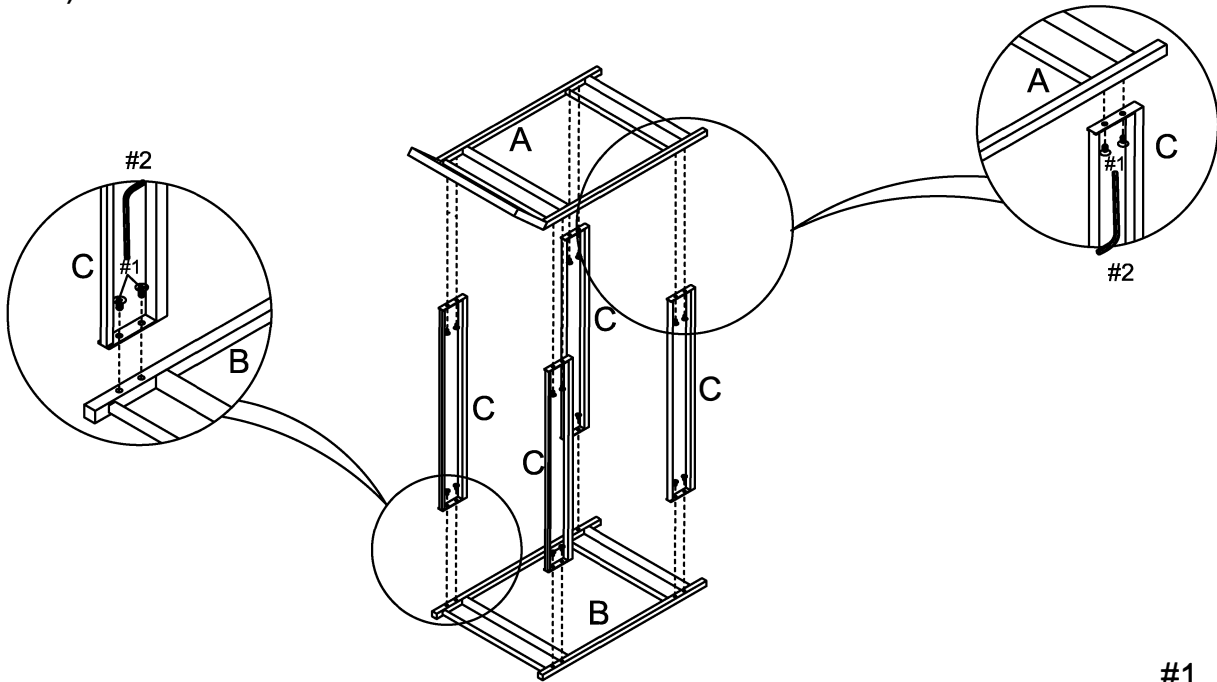

#1  x 16

#2  x 1

Step 2. Attach locking casters (part E) and casters (part F) to front panel (part A) and back panel (part B) using wrench (part #3).

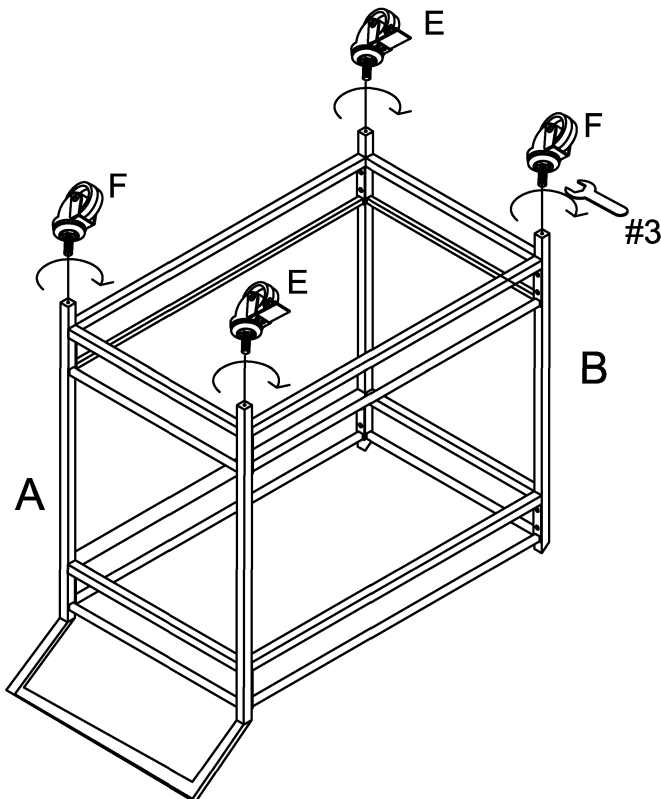

#3  x 1

Step 3. Carefully turn unit upright. Put glass shelves (part D) into place.

