

UNIQUE[®]

APPLIANCES

== *Classic* ==
by UNIQUE

PROPANE PIZZA OVEN

MODEL NUMBER: UNQ-PZ12CTH LP, UNQ-PZ16CTH LP



OWNER'S GUIDE

serial number:



JULY25V1

TABLE OF CONTENTS

Important safety information.....	3	Care and maintenance.....	14
Best practices for safety	6	Troubleshooting	16
Parts included	7	Rating plate	17
Assembly	8	Warranty	18
Connecting the gas cylinder.....	9	Appliance information	19
Disconnecting the gas cylinder.....	10	Product registration	19
Converting to fixed fuel systems	11	Contact us	19
Operation	13		

WELCOME

Congratulations! You have purchased one of the most efficient cooking products available on the market today. We are proud of our quality products and we believe in the dependable service we provide.

Before using the appliance, read through this manual carefully including all the information on safety, installation, operation, and cleaning. These guidelines do not cover every possible condition or situation that may occur. Be safe using common sense and caution when installing, operating and cleaning this appliance. If you are unsure about any of these instructions or warnings, contact your local product dealer or Unique Appliances for assistance.

NEED HELP?

Before you call for service, here are a few things you can do to help us serve you better.

Read this owner's manual carefully before installing and using your appliance: It contains instructions to help you use and maintain your appliance properly. We are not responsible for the damage occurred due to misuse.

Follow all instructions on your appliance and instruction manual, and keep this manual in a safe place to resolve any problems that may occur in the future.

Visit our website: Our website www.UniqueAppliances.com will give you access to self service tools, FAQs and much more.

If you receive a damaged appliance: Immediately contact the retailer that sold you the appliance.

Save time and money: Check the troubleshooting section at the end of this manual before calling. This section will help you solve common problems that may occur.

CALIFORNIA PROP 65 WARNING



This product can expose you to chemicals including Diisononyl Phthalate (DINP) which is known to the State of California to cause cancer.

For more information go to www.P65Warnings.ca.gov

IMPORTANT SAFETY INFORMATION

These warnings are provided in the interest of your safety. Please ensure that you understand them before installing or using this pizza oven. Your safety is of paramount importance. To reduce the risk of fire, burn hazard or other injury, read this safety manual carefully and completely before using this appliance. If you are unsure about any of these meanings or warnings, contact your local product dealer or Unique Appliances for assistance.

This instruction manual contains important information necessary for the proper assembly and safe use of the appliance. Read and follow all warnings and instructions before assembling and using the appliance. Follow all warnings and instructions when using the appliance.

This manual includes a list of required parts necessary for the safe operation of the appliance, directions for proper assembly and for assembly of installed parts and accessories supplied with the appliance, and proper procedures for gas leak testing. Keep this manual for future reference.



DANGER

- Never operate this appliance unattended.
- If a fire should occur, keep away from the appliance and immediately call your fire department. Do not attempt to extinguish an oil or a grease fire with water.
- Failure to follow these instructions could result in fire, explosion or burn hazard which could cause property damage, personal injury or death.

If you smell gas:

- Shut off gas to the appliance.
- Extinguish any open flame.
- If odor continues, keep away from the appliance and immediately call your gas supplier or fire department.

Failure to follow these instructions could result in fire, explosion or burn hazard which could cause property damage, personal injury or death.



WARNING

FOR OUTDOOR USE ONLY

- The appliance is a portable pizza oven for outdoor use. It is not intended for commercial use. Any other use or modification of this appliance is considered improper use and may pose considerable danger.
- This appliance is set to supply butane/propane mixture gas using a 50 millibar regulator.
- Keep the fuel supply hose away from any heated surface(s).
- Do not use this oven on or under any apartment or condominium balcony or deck.
- This appliance is not intended to be installed in or on a boat or in/on a recreational vehicle.
- This appliance is intended only for outdoor use, and should not be used in a building, garage, or any other enclosed area.
- Minimum clearance from sides of unit to combustible construction is 610mm (24 inches).
- Minimum clearance from back of unit to combustible construction is 915mm (36 inches).
- The appliance should not be located or used under overhead unprotected combustible construction materials or surfaces. For a grill, fryer or broiler, the minimum clearance shall be at least 10ft (3m) from any structure or combustible material.
- The appliance must not extend beyond the surface on which it sits.

IMPORTANT SAFETY INFORMATION (continued)



.WARNING

- No flammable materials should be within 3 meters around the appliance (e.g., awnings, wooden terraces, or furniture).
- Keep the cooking area (3-meter radius around the appliance) free of fire sources, such as ignition devices on water heaters, electrical appliances, and flammable vapors/liquids like gasoline and alcohol.
- Do not place flammable items on or in the appliance.
- Do not move the appliance when in use.
- The use of alcohol, prescription or non-prescription drugs may impair the consumer's ability to properly assemble or safely operate the appliance.
- This device should never be used by children. This device is not intended for use by people with (including children) sensory or intellectual impairment, lack of experience and knowledge. They must receive guidance on the risks associated with the device and be supervised by a person responsible for its safety.
- Keep out of reach of children. Keep children and pets away from the appliance at all times.
- Have a fire extinguisher and first aid kit at hand.
- This appliance gets very hot. Use included pizza peel to manipulate pizzas. Wear protective gloves when handling hot parts.
- Do not use the appliance while wearing loose, draping or wide-sleeved clothes.
- Never let clothing or other flammables come close to or in contact with any burner or hot surface until it has cooled. The fabric could ignite, causing serious injury.
- This appliance is not intended for and should never be used as a heater.
- Do not store gas cylinders in a building, garage or any other enclosed area and keep them out of reach of children at all times.
- Do not store or use gasoline or other flammable liquids/gases in the vicinity of this appliance.
- Do not store full or empty gas cylinders near this appliance.
- Check all gas supply fittings for leaks before each use. Do not use the appliance until all connections have been checked and do not leak.
- Do not smoke while leak testing. Never leak test with an open flame.
- Clean and inspect the hose before each use of the appliance. If there is evidence of abrasion, wear, cuts, or leaks, the hose must be replaced prior to the appliance being put into operation. The replacement hose assembly shall be that specified by the manufacturer.
- When lighting, keep your face and hands as far away from the appliance as possible.
- When using a match to light the appliance, make sure to use the included matchstick holder.
- Spiders and insects can nest inside the burner of the appliance and disrupt gas flow. Inspect the burner at least once a year. A clogged tube can lead to a fire beneath the appliance.
- Do not connect the device to a natural gas network. These valves and nozzles are designed specifically for liquefied gas.
- Liquid gas is not natural gas. Using natural gas in a liquid gas installation, or using liquid gas in a natural gas installation, is a dangerous act that nulls the warranty. Check for gas leaks and obstacles in the burner before use.
- After a period of storage or non-use, check for gas leaks and clogged burners before use. Be sure to turn off the gas source switch on the cylinder and disconnect the pressure regulator before moving the cylinder. Never remove a gas cylinder from its designated operating position for use.
- Do not operate the equipment when the gas cylinder is not in the specified correct position.
- No electrical power lines, gas and fuel supply hoses should be placed near or on any heated surfaces.

IMPORTANT SAFETY INFORMATION (continued)



.WARNING

- Do not modify the appliance. Any sort of modification strictly prohibited. Sealed parts are not to be manipulated by the user. Do not disassemble injectors.
- Never close the oven with aluminium foil or any other material, as this will impede the ventilation of the burner, creating a potentially dangerous situation that may result in property damage and/or personal injury.
- The burner tube openings must be positioned properly over the valve orifices.
- Check screws and tighten if necessary before use to ensure stability.
- Do not use charcoal, ceramic briquets or lava rocks in the appliance.
- Keep ventilation openings free and clear of debris.
- Flammable liquids may cause flash flames or deflagrations. Never use ignition liquids (e.g. lighter fluids, petrol or spirits).
- If a gas leak occurs, turn off the gas supply.
- Turn off the gas supply at the gas cylinder after use.
- This appliance must be kept away from flammable materials during use.
- The appliance will be hot during and after use. Use insulated oven mitts or gloves for protection from hot surfaces.
- Do not store objects or materials in the storage area under the appliance. Do not block the flow of combustion air to the underside of the control panel and the firebox.
- Never attempt to perform repairs on gas components. For repairs, please contact your dealer for more information. Failure to follow this warning may cause a fire or explosion which can cause serious injury, death or damage to property.
- Some parts of this appliance have sharp edges. Wear protective gloves during setup and use.



LP GAS CYLINDER WARNING

- Do not store spare liquid propane gas cylinder under or near this appliance.
- Never fill the cylinder beyond 80 percent capacity.
- Liquid propane cylinder must be fitted with an OVERFILL PROTECTION DEVICE (OPD).
- The cylinder supply system must be arranged for vapour withdrawal.
- Changing the gas cylinder shall be carried out away from any source of ignition.
- Only use the pressure regulator and hose assembly that is supplied with the appliance or compatible regulators. You can obtain it after consulting the store where you made the purchase.
- The hose of the gas hose assembly must not be bent and must not be longer than 1.5 meters. The hose should not be twisted or kinked when attached to the gas cylinder.
- Only gas cylinders with a diameter not exceeding 310 millimeters, a maximum height of 600 millimeters and containing 5 to 13 kilograms (standard 20 lb tank) of liquefied gas are permitted.
- Do not attempt to disconnect the pressure regulator and hose assembly or any gas fitting while the appliance is in operation or still hot.
- Do not use a damaged gas cylinder. A dented or rusty gas cylinder or a gas cylinder with a damaged valve may be hazardous and should be replaced with a new one immediately.
- Although the gas cylinder may appear to be empty, gas may still be present and the cylinder should be transported and stored accordingly.

BEST PRACTICES FOR SAFETY



- If the information above is not followed exactly, a fire resulting in death or serious injury may occur.
- *This manual states that the installation must conform with local codes or, in the absence of local codes, with the National Fuel Gas Code, ANSI Z223.1/NFPA 54, Storage and Handling of Liquefied Petroleum Gases, ANSI/NFPA 58; or Natural Gas and Propane Installation Code, CSA B149.1; Propane Storage and Handling, CSA B149.2*
- *The cylinder to be used must be constructed and marked in accordance with the specifications for LP gas cylinders, U.S. Department of Transportation (DOT) or the Standards for cylinders, Spheres and Tubes for the Transportation of Dangerous Goods, CAN/CSA-B339.*

When properly cared for, your oven will provide safe, reliable service for many years. However, extreme care must be used as the oven produces intense heat that can increase the risk of accidents.

When using this oven basic practices must be followed, including but not limited to following:

- Do not repair or replace any part of the oven unless specifically recommended in this manual. All other service should be referred to a qualified technician.
- Do not heat unopened food containers as a build-up of pressure may cause the containers to burst.
- When lighting the burner, always pay close attention to what you are doing.
- When using the oven, do not touch the outer shell, stone baking board or immediate surroundings as these areas become extremely hot and could cause burns.
- Do not use the oven to cook extremely fatty meats or other products which could flare up.
- Keep the area surrounding the oven free from combustible material including fluids, trash and vapours such as gasoline or charcoal lighter fluid.
- Do not obstruct the flow of combustion and ventilation air.
- Never use the oven in extremely windy conditions.
- Never use the oven indoors - risk of carbon monoxide poisoning.
- The temperature under the oven is high. Do not place the oven on a table with flammable tablecloths, plastic or any other inflammable materials.
- If the burner goes out during operation, turn off all gas valves. Wait for five minutes before attempting to re-ignite. Follow the ignition Instructions on page 13.

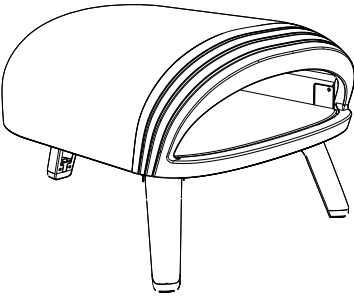
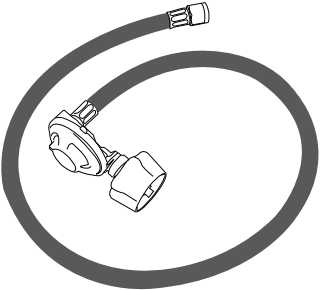
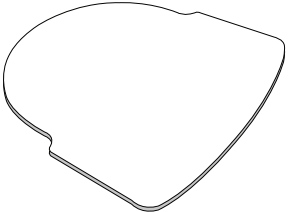
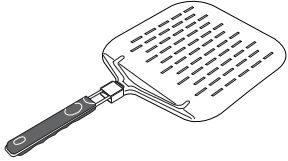
PARTS INCLUDED

Unique Classic Retro Propane Pizza Oven 12" or 16"	
Gas hose and regulator kit	
High Temperature Baking Stone	
Folding Pizza Peel (pizza spatula)	
Ignition Rod	

Accessories sold separately:

- Heavy duty carrying bag
- Oven scraper brush
- Quick connectors for fixed fuel system installation

To order:

- Visit www.uniqueappliances.com

or

- Contact Unique customer service:

Toll-free: 1-877-427-2266 or 1-905-827-6154

Email: info@UniqueAppliances.com

ASSEMBLY

WARNING

Improper assembly can be dangerous. Be sure to follow the assembly instructions carefully. Before assembly, make sure all parts are present. If any part is missing or damaged, do not attempt to assemble the appliance. Contact customer service for replacement parts.

1

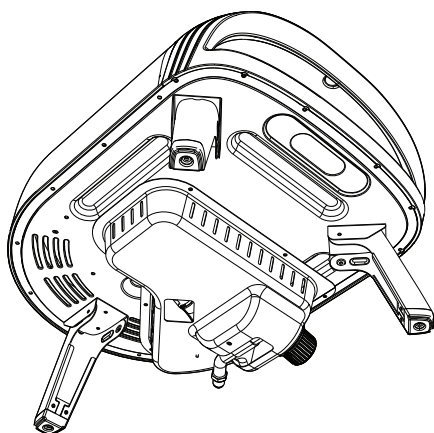

Unfold the legs

- 12" oven = 3 legs (shown)
- 16" oven = 4 legs

2

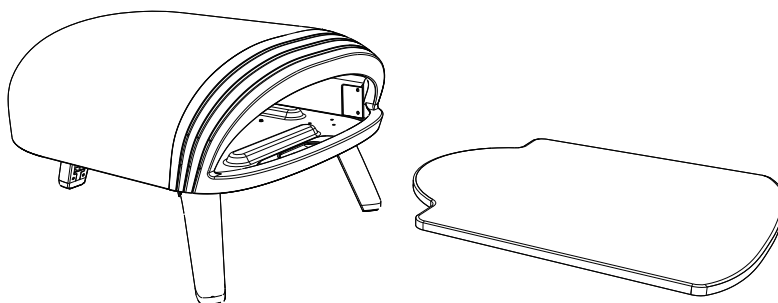

Insert the dry baking stone fully into the oven.

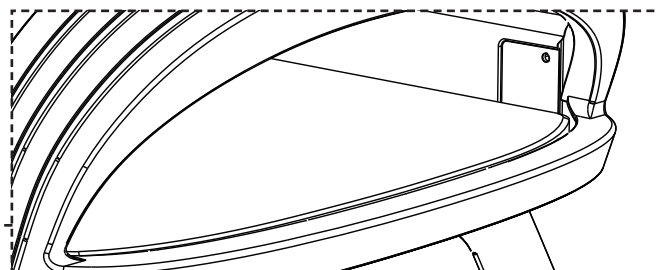
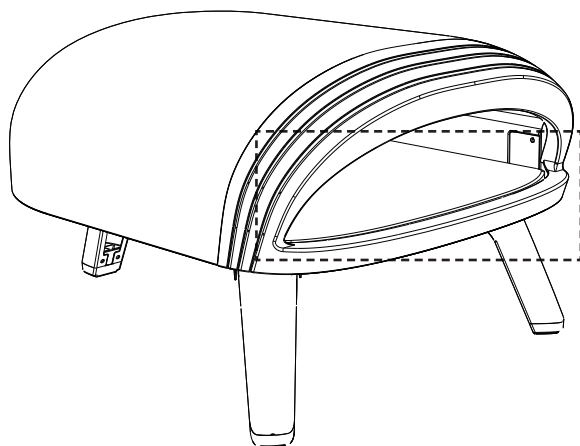

NOTE: Ensure that the baking stone is fully inserted so that there is no overhang outside of the oven. Make sure the baking stone is level.

IMPORTANT

- Fold out the legs completely. **NOTE:** the 12" oven has 3 legs (shown above), the 16" oven has 4 legs.
- Never operate the oven upside down.
- Set up the oven on a level, stable and non-flammable surface. Make sure that the oven is placed higher than the valve of the upright gas cylinder (eg: the oven on a stable tabletop, with the gas cylinder set upright on the ground below.)
- Insert the dry baking stone fully into the oven. Caution: do not use a wet stone in the oven as it may crack. If wet, the baking stone can be dried in a conventional oven at 60°C/140°F for 2 hours before use.

CONNECTING THE GAS CYLINDER

NOTE: Regulators will vary depending on region.

- Please always keep the gas bottle in upright position.
- The size for 20 lbs LP gas cylinder is 12.2 inches in diameter and 17.9 inches tall.
- If the appliance is not in use, the gas must be turned off at the supply cylinder.
- The cylinder used must include a collar to protect the cylinder valve.
- The minimum distance for the appliance and the 20 lbs gas tank is 25 inches apart.

WARNING

Only use gas cylinder approved according to DIN EN 417 with a gas mixture of 80% Butane/20% Propane. Do not use a damaged gas cylinder. A dented or rusty gas cylinder or a gas cylinder with a damaged valve may be hazardous and should be replaced with a new one immediately. Be sure the pressure regulator is mounted with the small vent hole pointed downward so that it will not collect water. This vent should be free of dirt, grease, bugs, etc.

The joint where the hose connects to the gas cylinder must be leak-tested every time the gas cylinder is changed or reconnected.

Connecting the liquid propane gas cylinder

1. Set control knob on the cylinder valve to the **OFF** position (triangle pointing upwards).
2. Make sure the burner valve is in **OFF** position.
3. Inspect the valve connections, port and regulator assembly. Remove any debris and inspect the hose for damage.
4. Make sure the the rubber seal within the gas cylinder valve is in a good condition. If it is showing wear or damage, it must be replaced. Contact Unique Appliances for a replacement seal.
6. Screw the pressure regulator counter-clockwise tightly on to the gas cylinder by hand.
7. Open the gas valve on the pressure regulator by one full turn. If you see, smell or hear the hiss of escaping gas, close the valve immediately again. Otherwise, close the valve after the gas hose is filled and the pointer of the pressure gauge has come to a complete standstill within the green area.
8. When connecting the regulator assembly to the valve, hand tighten the nut clockwise until it stops. Using a wrench could damage the quick coupling nut and result in a hazardous situation.
9. Open the cylinder valve fully by turning the valve counter-clockwise.
10. Before lighting the oven, spray leak detector or use a soap and water solution at all the joints of the gas system.
11. If active bubbles appear, there is a leaking joint. Close the valve immediately again and check the connection of the joint. Repeat the previous steps from step 3 on. If the leak can not be eliminated, do not try to perform any repair work - contact the point of purchase or your local liquid propane dealer for repairs.
12. If no bubbles form, the gas system is ready for use. Wipe away any remaining leak testing liquid. Make sure that the valve is closed after every use or leakage test.

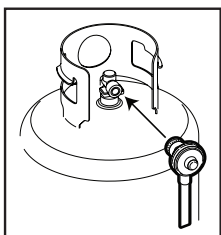

QCC1 gas regulator

This gas fitting is clockwise. Make sure that the tank is completely switched off and screw the regulator as far as possible into the gas tank valve.

CONNECTING THE GAS CYLINDER (continued)



Positioning the gas hose

WARNING: The hose pipe can be a tripping hazard. Always route the gas hose away from the oven. The hose must not touch the oven body. Do not wrap or route gas hose around the legs of the oven.

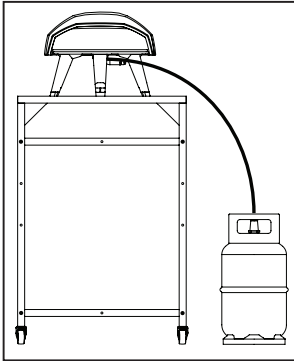

Correct hose position

Route the gas hose away from the oven, with no kinks or tight curves.

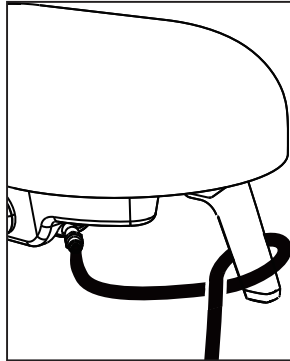

Incorrect hose position

Ensure the hose does not have any kinks or tight curves, and do not loop the hose around legs.

DISCONNECTING THE GAS CYLINDER

Disconnecting the liquid propane gas cylinder

1. Turn the oven burner valve **OFF** and make sure the oven is cool.
2. Turn the liquid propane cylinder valve **OFF** by turning clockwise until it stops.
3. Detach the regulator assembly from the cylinder valve by turning the quick coupling nut counter-clockwise.
4. Cover the cylinder valve outlet with a dust cap whenever the cylinder is not in use. Only install the type of dust cap on the cylinder valve outlet that is provided with the cylinder valve. Other types of caps or plugs may result in leakage of propane.

CONVERTING TO FIXED FUEL SYSTEMS (LARGE PROPANE TANK)



WARNING

FIRE, EXPLOSION, AND CARBON-MONOXIDE HAZARD

If the information in these instructions is not followed precisely, a fire, explosion, or production of carbon monoxide may result, causing property damage, personal injury, or loss of life.

This conversion kit should be installed by a qualified agency in accordance with the appliance manufacturer's instructions and all applicable codes and requirements of the local authority. The qualified agency is responsible for the proper installation of this kit. The installation is not proper and complete until the operation of the converted appliance is verified according to the manufacturer's instructions supplied with the kit.

- **This kit is only applicable with Unique Classic Retro 12 and Unique Classic Retro 16 pizza ovens.**
- NOT INCLUDED: DH22 model hose and quick connectors to Fixed Fuel System
- The appliance and its individual shutoff valve must be disconnected from the gas supply piping system during any pressure testing of that system at test pressures in excess of 1/2 psi (3.5kPa).
- The appliance must be isolated from the gas supply piping system by closing its individual manual shutoff valve during any pressure testing of the gas supply piping system at test pressures equal to or less than 1/2 psi (3.5kPa).

Instructions

1. **Caution:** Before proceeding with the conversion; shut off the gas supply and ensure the oven is cool to the touch. Remove the baking stone and turn the oven upside down.
2. Remove the gas hose using a 19mm/ 3/4" wrench.

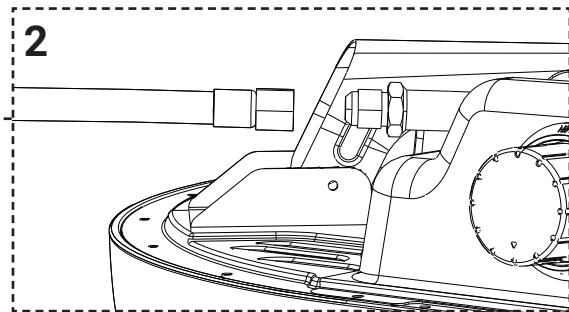
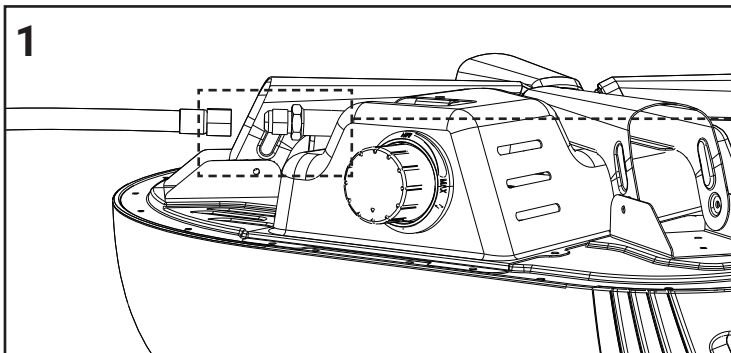

CONVERTING TO FIXED FUEL SYSTEMS (continued)

3. Attach DH22 gas hose using a 19mm/ ³/₄" wrench.

4. Attach quick connectors at the end of the gas hose and connect to the fixed fuel system.

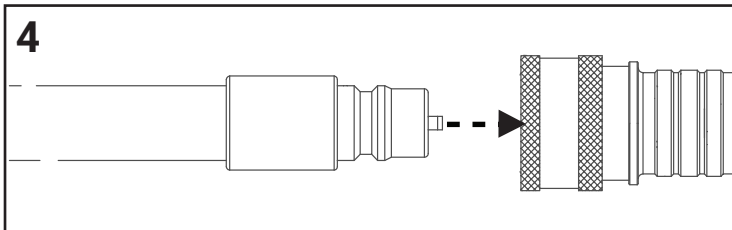
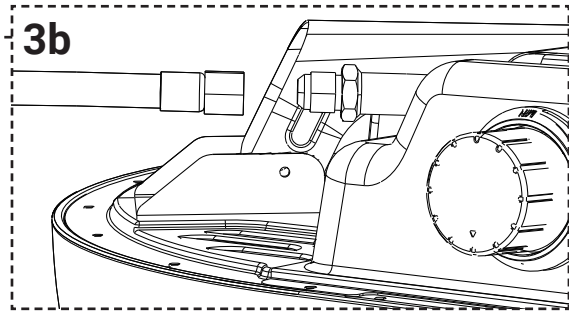
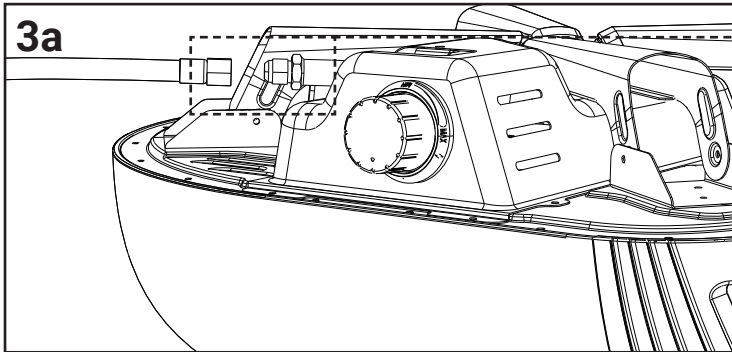

5 Perform Leak Test

Ensure the hose connection is safe and secure.

Note

Although the gas connections of the appliance are leak tested prior packing and shipment, a complete leak test must be performed at the installation site.

Before each use, check all the gas connections for leak testing using the procedure listed below. If the smell of gas is detected at any time, immediately stop using the oven and check the entire system for leaks.

Before testing

Make sure all packing material has been removed from the appliance.

Use a commercially prepared, water-based leak detector, or make a solution of one part liquid detergent and one part water. You will need a spray bottle, brush or rag to apply the solution to the fittings.

To test

1. Turn the burner valve OFF.
2. Turn the liquid propane cylinder valve on counter-clockwise to open the valve.
3. Apply water-based leak detector or a soap and water solution to all gas fittings. Soap bubbles will appear where a leak is present.
4. If a leak is present, immediately turn the gas supply OFF and tighten leaky fittings.
5. Turn the gas back ON and recheck.
6. Should the gas continue to leak from any of the fittings, turn the gas supply OFF and contact customer service.

OPERATION



Using the baking stone CAUTION

- The baking stone is fragile and can crack or break if bumped or dropped.
- Do not use the pizza stone over an open flame.
- Extreme and/or sudden temperature changes can cause the baking stone to crack.
- Do not place frozen food on a hot baking stone.
- Do not cool down the pizza stone with water.
- After cleaning the stone with water, please dry the stone before use. This can be done in a conventional oven at 60°C (140°F) for 2 hours.
- Burnt-on food can be cleaned by flipping the stone - high oven temperatures will reduce food residues to ashes that can be easily wiped away once the stone/oven have completely cooled.

Control Knob

The Burner is controlled by a control knob. Once the burner is lit, the temperature can be set as required by setting the control knob between MAX (high temperature) and MIN (low temperature).

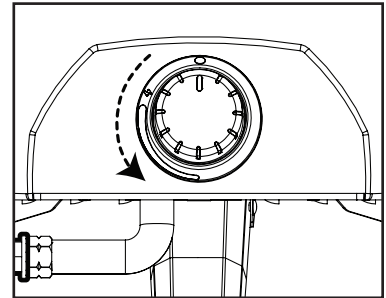

Using the oven

- The 12" pizza oven is rated at 15,354 BTU
- The 16" pizza oven is rated at 27,300 BTU

Pre-heat the pizza oven on maximum level for about 15 minutes before using it for the first time. This burns away any possible residues and may emit an unpleasant smell - this is normal and will dissipate quickly.

To begin:

1. Make sure the oven has been leak tested and properly placed.
2. Remove any remaining packing material.
3. Light the burner using the lighting instructions below

How to light the oven

To light the oven using the ignitor:

Read all instructions before lighting.

1. Make sure the control knob is in OFF position, and then turn the liquid propane cylinder valve ON by slowly turning counter-clockwise.
2. Push in and slowly turn the control knob counter-clockwise until you hear a click and the burner ignites.
3. Continue to push in the control knob for 5 seconds after ignition and then release. Turn the control knob further to the lower left.
4. If the burner doesn't light within 5 seconds, turn the knob OFF, wait 5 minutes and repeat the lighting steps.
5. Once lit, allow the pizza oven to pre-heat for 15 to 20 minutes before cooking.

CARE AND MAINTENANCE

To light with a match:

1. If burner will not light after several attempts using the control knob, the burner may be lit with a match.
2. If you have already attempted to light the burner using the control knob, wait 5 minutes for any gas to dissipate.
3. Insert a match into the matchstick holder, ignite the match and insert through the oven opening to the burner.
4. Push and turn the control knob to **HI** slowly, the burner should ignite immediately.
5. Continue to push in the control knob for 5 seconds after ignition and then release.
6. If the burner does not light within seconds, turn the control knob **OFF** and wait 5 minutes and try again.
7. Once lit, allow the pizza oven to pre-heat for 15 to 20 minutes before cooking.

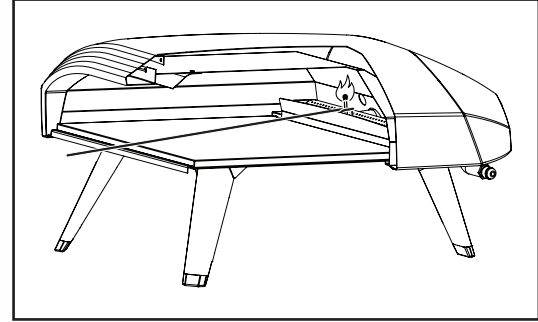

To turn the oven off:

- After removing the last pizza being prepared, allow the oven to operate at maximum temperature for 5 minutes longer to burn off any remaining food residues.
1. Push in the control knob and turn to the right until the triangle points upwards.
 2. Close the gas valve after the burner is off.

Cleaning and care

WARNING

Always set the control knobs to the OFF position and close the gas cylinder when the appliance is not in use. Make sure the appliance has cooled down before cleaning, moving or storing. Only use detergents that are food safe (e.g. no paint solvents or thinner.)

Burner Care

- Use a narrow bottle brush with a flexible handle (do not use a wire brush) and brush the entire outer surface of the tube burner to remove food residue and dirt.
- Clean any blocked port carefully with a wire (like a straight pin or bent paper clip.)
- Check the burner for damage, corrosion or enlarged holes. If any damage is found, the burner must be replaced.

Interior and exterior care

- Clean the appliance often, preferably after each cookout.
- The appliance should be cleaned at least once as year to inhibit rust formation.
- Do not mistake brown or black accumulation of grease and smoke for paint. Interiors of gas grills are not painted by the factory and should never be painted. Apply a strong solution of detergent and water or use an appliance cleaner with a scrub brush on the insides of the oven lid and the boom. Rinse by wiping with water and a clean cloth or sponge and allow to completely air dry. Do not apply caustic appliance/oven cleaner to painted surfaces.
- The outer shell of the appliance may fade with time and use. This will not affect performance.
- Store your Unique Classic Retro 12 oven out of direct sunlight and indoors where possible and when storing for extended periods of time. It should not be exposed to harsh weather conditions such as snow, heavy rain and strong winds.

CARE AND MAINTENANCE (continued)

Stainless Steel surfaces

To maintain your appliance's retro look, carefully wash the exterior and stainless steel surfaces with mild detergent and warm water and wipe dry with a soft cloth after each use. Wipe in the direction of brushed finishes to avoid leaving streaks or damaging the finish.

Gas hose and regulator

Before each use check hoses for any wear or damage. Replace any damaged hoses immediately. Make sure the hose assembly is not bent or kinked and does not contact any warm surface while the appliance is in use.

Always keep the pressure regulator clean and ensure that the vent hole on the lower side of the pressure regulator is not blocked.



WARNING

It is recommended to replace the pressure regulator and hose assembly every 5 years, however, some countries mandate that pressure regulator and hose assemblies should be replaced after a shorter period of use, which should be followed. Contact Unique Appliances for a replacement pressure regulator and hose assembly.

• **Toll-free:** 1-877-427-2266 or 1-905-827-6154

• **Email:** info@UniqueAppliances.com

Please use this equipment only with CE-certified hose assemblies and pressure regulators.

Storing your oven

1. Close the valve on the gas cylinder.
 2. Set the control knob to off (triangle pointing upwards).
 3. Wait for the pizza oven to cool completely.
 4. Remove the gas cylinder from the oven by unscrewing the gas hose clockwise.
 5. Thoroughly clean the oven.
 6. Store in a dry, indoor location (e.g. garage or cellar).
 7. Store the gas cylinder outdoors in a dry, well ventilated location, out of reach of children.
- Do not expose the oven to direct sunlight or harsh weather conditions for an extended period of time.
 - When removing the appliance from storage, check for tube burner obstructions before use.

Disposal



This appliance must not be disposed of as household garbage or unsorted municipal waste. To help conserve resources and protect the environment, it must be returned to a designated regional collection point for waste management and/or recycling. Contact your local authorities for more information.

Do not allow children to play with plastic bags and packaging material - risk of injury and suffocation. Store packing materials out of the reach of children, or dispose of them in an environmentally responsible manner.

TROUBLESHOOTING

PROBLEM	POSSIBLE CAUSE	SOLUTION
Burner will not light	<ul style="list-style-type: none"> • No gas flow • Coupling nut and regulator not fully connected • Obstruction of gas flow • Disengagement of burner to valve • Incorrect assembly 	<ol style="list-style-type: none"> 1. Check to see if propane tank is empty 2. Turn the coupling nut about one-half to three quarters additional turn until solid stop. 3. Tighten by hand only - do not use tools 4. Clear burner tube 5. Re-engage burner and valve 6. Check steps in assembly instructions
	<ul style="list-style-type: none"> • The electrodes are covered with cooking residue 	<ol style="list-style-type: none"> 1. Clean the burner as described in Cleaning and Care (page 14). Degrease the electrode tips by gently wiping with rubbing alcohol.
	<ul style="list-style-type: none"> • The electrodes are bent and/or are too far from the burner 	<ol style="list-style-type: none"> 1. Gently bend the electrodes back towards the burner.
Yellow/orange flames, noticeable smell of gas	<ul style="list-style-type: none"> • The burner is clogged by spiders/insects or other obstructions 	<ol style="list-style-type: none"> 1. Clean the burner as described in Cleaning and Care (pg. 14)
Sudden drop in gas flow or low flame	<ul style="list-style-type: none"> • Out of gas • The gas hose is bent or kinked. 	<ol style="list-style-type: none"> 1. Check for gas in propane tank 2. Turn off gas control knob, wait 30 seconds and light oven. If flames are still low, turn off gas control knob and propane tank valve. Disconnect regulator. Reconnect regulator and leak test. Turn on propane tank valve, wait 30 seconds and then light oven. 3. Ensure the gas hose is straight and unkinked.
Flames blow out	<ol style="list-style-type: none"> 1. High or gusting winds 2. Low on propane gas 	<ol style="list-style-type: none"> 1. Turn front of oven away from wind 2. Refill propane tank 3. Refer to instructions "sudden drop in gas flow" (above)
Flare-up	<ol style="list-style-type: none"> 1. Grease build up 2. Excessive fat in meat 3. Excessive cooking temperature 4. Excess flour on the cooking surface 	<ol style="list-style-type: none"> 1. Clean oven 2. Trim fats from meat before cooking 3. Adjust (lower) temperature accordingly 4. Brush remnant flour from cooking surface 5. Flip stone
Flashback (fire in burner tube, roaring sound from burner)	<ol style="list-style-type: none"> 1. Burner and/or burner tubes are blocked 2. Pressure drop during ignition 	<ol style="list-style-type: none"> 1. Turn gas control knob off. Clean burner and/or burner tubes. 2. Turn off oven, ensure the tank valve is fully open (if applicable) and relight.

RATING PLATE

			
Product name		Gas pizza oven	
Model	UNQ-PZ12CTH O LP UNQ-PZ12CTH R LP UNQ-PZ12CTH T LP UNQ-PZ12CTH MB LP	UNQ-PZ16CTH O LP UNQ-PZ16CTH R LP UNQ-PZ16CTH T LP UNQ-PZ16CTH MB LP	
Version	CSA certified	CSA certified	
Power	15354 BTU	27300 BTU	
Gas type	Propane	Propane	
Gas pressure	11" W.C.	11" W.C.	
Injector size	Propane 1.02	Propane 1.02	
Product size	22.72 × 16.20 × 11.89 in	23.78 × 25.98 × 14.96 in	
Net weight	22.4 lbs	40.9 lbs	
Pizza size suitable for	0 ≤ 12inch diameter	0 ≤ 16inch diameter	
USE OUTDOOR ONLY.			
READ THE INSTRUCTIONS BEFORE USING THE APPLIANCE.			
WARNING: ACCESSIBLE PARTS. MAY BE VERY HOT. PLEASE KEEP YOUNG CHILDREN AWAY.			
			

WARRANTY

STANDARD WARRANTY

This appliance has been designed for domestic or residential use only. If properly installed, adjusted, and operated under normal conditions in accordance with printed instructions, it will satisfactorily perform the functions expected of this type of appliance. If the appliance fails due to a defect in material or workmanship within one year (standard warranty period) from the original date of purchase:



Unique will, at our option, repair, exchange, or otherwise correct any part(s) found to be defective—excluding surface finish.

EXTENDED WARRANTY

Subject to the terms outlined below, Unique will extend the standard warranty period for select pizza oven models when customers register their product within 60 days of purchase at uniqueappliances.com/product-registration. Products eligible for extended coverage will be clearly identified on our website. Extended warranty period on eligible model is 5 years.

Terms of Extended Warranty:

- Applies only to Qualifying Products as listed on the warranty registration page.
- The Extended Warranty Period will begin on the product's original purchase date.
- Proof of purchase is required for all claims.
- The warranty is transferable, provided the new owner has the original proof of purchase.
- Any replacement parts issued under warranty are covered by the remaining time on the original or extended warranty period.
- Altering the product in any way will void the warranty.
- Warranty support is subject to the product being used in accordance with the owner's manual.

WHAT IS COVERED

During the applicable warranty period (standard or extended), Unique guarantees the product will be free from material defects in materials and workmanship.

Specifically:

- Faulty components will be repaired or replaced.
- If the defect renders the product unusable, the full unit may be replaced.
- Unique may request the return of the product for diagnostic purposes before issuing a replacement.

WHAT IS NOT COVERED

The following are excluded from both standard and extended coverage:

- Normal wear and tear
- Discoloration or heat tarnishing
- Surface rust, water damage, or corrosion from salt air/humidity
- Severe weather or natural disasters
- User error, including misuse or incorrect fuels
- Use outside the country of purchase
- Any alteration of the product
- Minor warping from heat that does not impair functionality
- Installation not compliant with instruction manual
- Use for commercial or industrial purposes
- Power failures, fire, theft, or acts of God
- Service calls due to installation errors or customer education
- Freight or transit damage
- Any use outside of intended design or environment (e.g., outdoor use where not approved)

OWNER RESPONSIBILITIES

- Register the product (for extended warranty eligibility) within 60 days of purchase.
- Provide model and serial number when requesting service.
- Retain your proof of purchase—required for all claims.
- Make the appliance accessible for service and cover additional charges for remote locations.
- Any service calls requested to demonstrate use or correct non-warranty issues are the responsibility of the owner.

CLAIMS PROCESS

To initiate a warranty claim, customers must:

1. Visit uniqueappliances.com/technical-support or contact Customer Service at 1-877-427-2266.
2. Submit proof of purchase, serial number, and photographs/videos of the issue.
3. Cooperate with troubleshooting steps as requested by support.

If the issue qualifies under warranty, Unique will, at our discretion, repair or replace the product. If no fault is found under warranty terms, the product may be returned at the customer's expense.

LIMITATION OF LIABILITY

This warranty is a voluntary manufacturer's warranty and does not affect your statutory rights. In no event shall recovery under this warranty exceed the original purchase price of the appliance.

Design updates made by Unique do not imply prior models are defective. Warranty service does not include design upgrades.

APPLIANCE INFORMATION

(manual copy - keep with your records)

To make the care and servicing of your appliance easy and efficient, please record the following information for future reference:

Model:

Serial Number:

Purchased From:

Date Purchased:

PRODUCT REGISTRATION

Please visit our website at <https://uniqueappliances.com/pages/product-registration> to register your product.



NOTES

CONTACT US

For questions related to the operation, safety or the purchase of your oven, please contact your dealer for more information. For general information, contact our customer service department:



Email

info@UniqueAppliances.com



Toll-free

1-877-427-2266 or 1-905-827-6154
available during regular business hours,
8:30 am to 4:30 pm, EST.



Website

www.uniqueappliances.com



© 2025 Unique Appliances Ltd., 2245 Wycroft Road,
Oakville, Ontario, Canada, L6L 5L7

www.uniqueappliances.com