

ASSEMBLY INSTRUCTION FOR ACME FURNITURE

Thank you for purchasing the quality product. Be sure to check all packing material carefully for small parts which may have come loose inside the carton during shipment. Separate, identify and count all parts and metal hardware. Compare with all parts are present. If any part(s) are missing or damaged, please contact your local furniture dealer. For efficient and speedy service, please indicate the model number and code letter of part(s) needed.

*****Do not fully tighten screws until fully assembled.*****

COFFEE TABLE

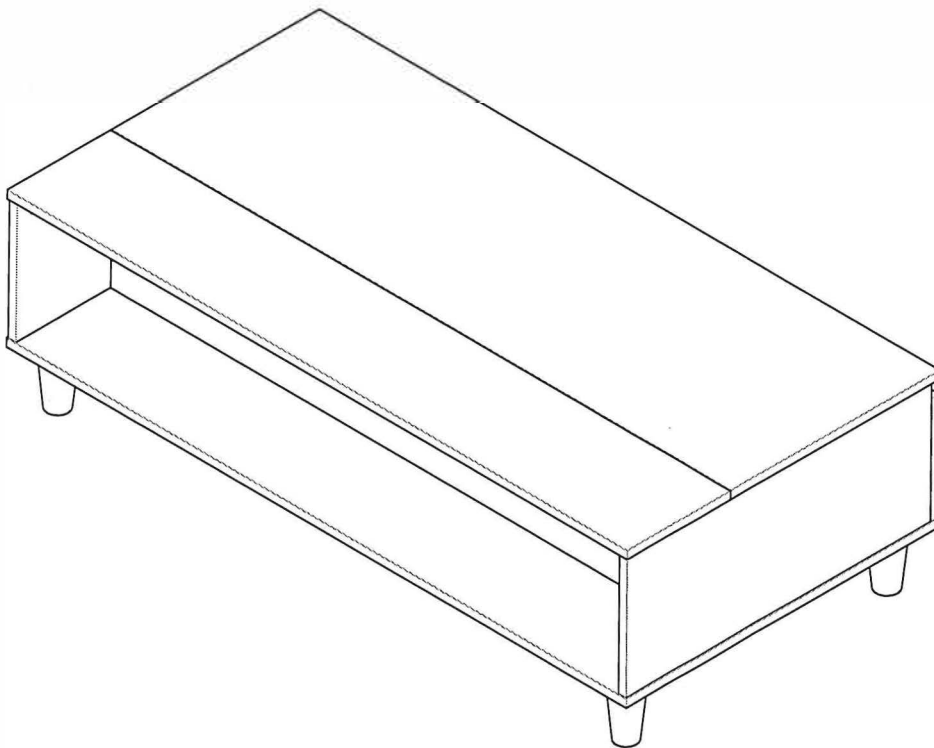

DIMENSIONS

Width - 47.24"
Depth - 23.62"
Height - 14.17"

ASSEMBLY INSTRUCTIONS

PRECAUTIONS

Because our products may be challenging for beginners, we deeply understand that you may encounter some difficulties. To avoid discouragement, we have provided some useful tips, as follows.



Enough Open Space -

Ensure that there is enough space for movement during assembly.



Prevent Scratching -

When assembling furniture, use cardboard, blankets or a carpet areas to prevent scratches.



More than two people -

Always have at least two people to help transport and assemble the product to avoid potential injury and/or damage.



Question -

If there is any problem with the assembly process, you can call us.

ASSEMBLY INSTRUCTIONS

CAM LOCK FASTENER

Every cam bolt must have a cam lock connector to hold the parts together.

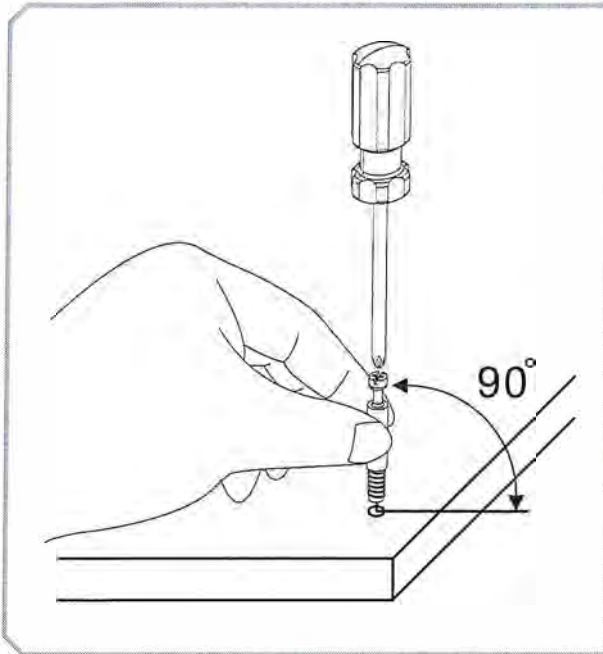

1.

When assembling, the hardware parts and the wooden board must be kept vertical, and the tools must be in full contact with the hardware groove.

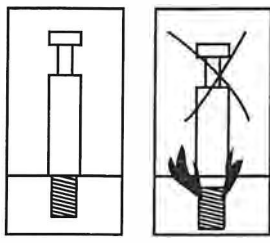

Caution:
Do not use excessive force to avoid over-fastening, or even exceed the entire board.

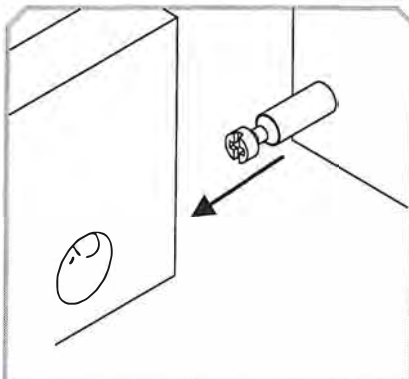

2.
Insert the cam lock pin into the hole of joint panel.

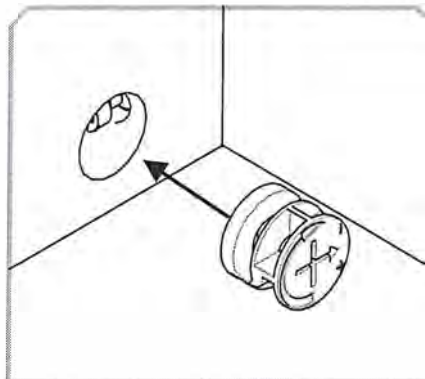

3.
The cam lock nut opening side (or arrow) aligned with the cam lock pin.

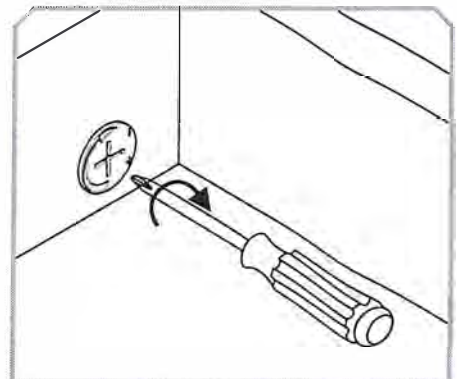

4.
Slowly rotate the cam lock clockwise until it stops rotating.



Caution:
When assembling the cam lock, do not use an electric screwdriver to avoid damage to the board or hardware due to excessive force.

ASSEMBLY INSTRUCTIONS

SLIDE RAIL

The holes of the slide rail are in the same direction as the following page.

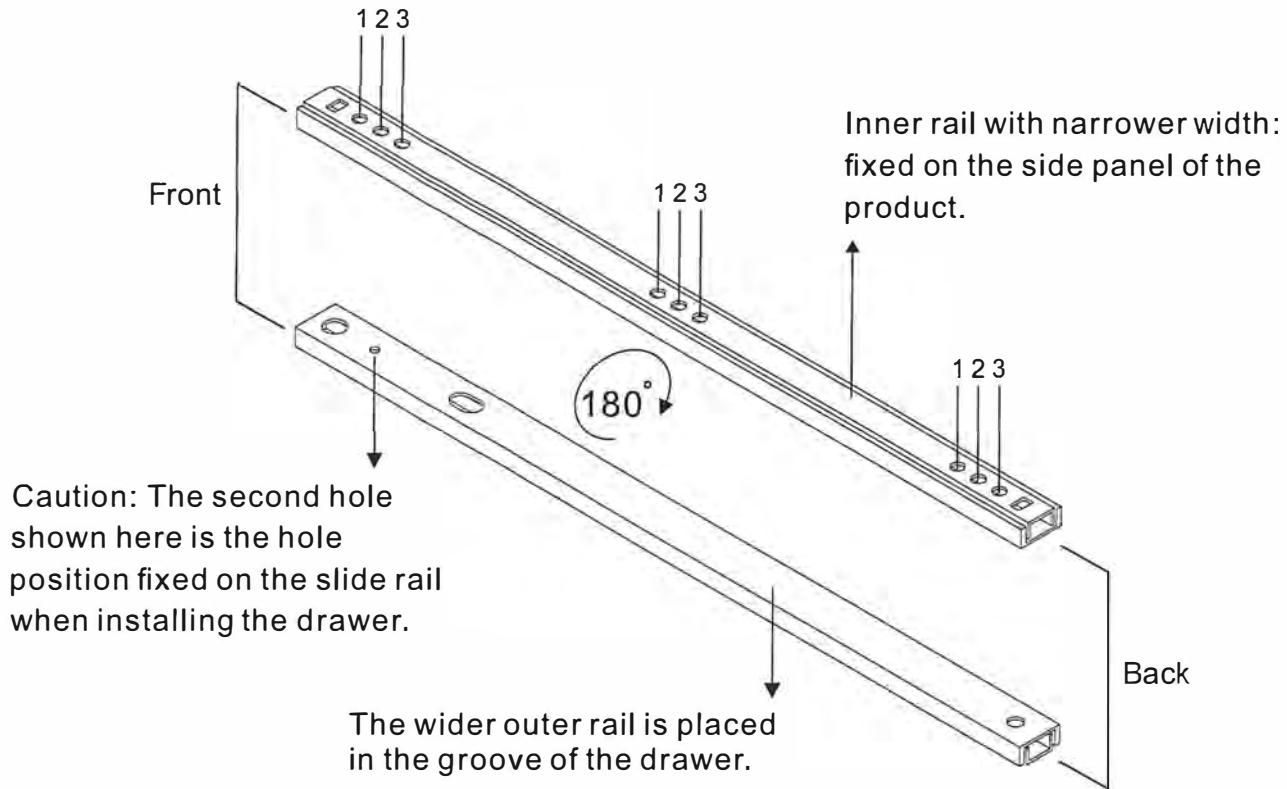

DOWEL

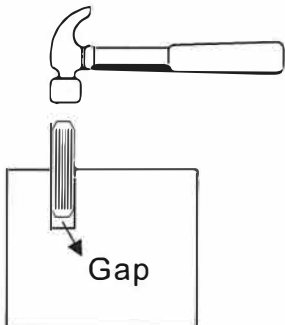

ATTENTION

Inserting wood dowels is likely to be tight, so wood dowels may not easily touch the bottom and damage the side panels during installation. It is recommended to slight hit the wooden pins with a hammer to eliminate the gap between the wood dowel and board.

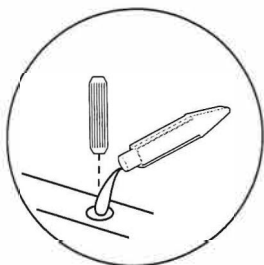

OPTIONAL

It is recommended to use white glue to increase the safety of the product. If you are worried about assembly errors, you can temporarily not add it, and then add it after confirming.

PARTS LIST

A X1 Large top

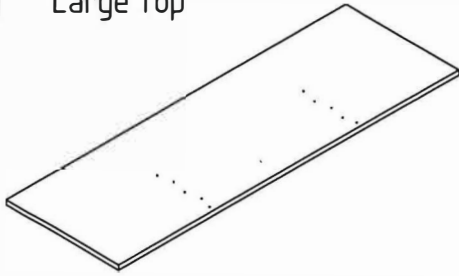

G X1 Right middle

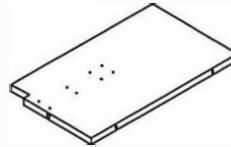

B X1 Small top

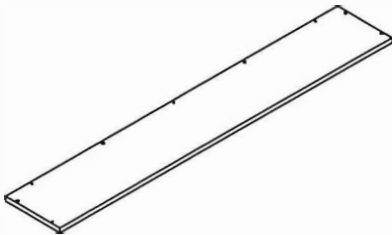

H X1 Left middle

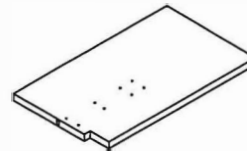

C X1 Right side

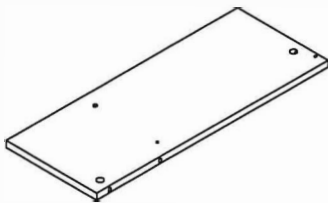

I X1 Bottom

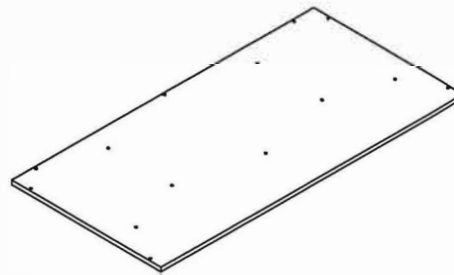

D X1 Left side

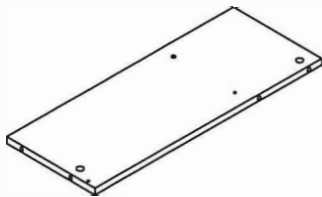

J X1 Front support



E X1 Back



K X1 Lifter support



F X1 Front side

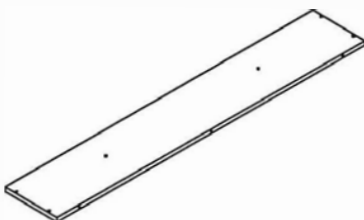

HARDWARE LIST

① X11 Cam bolt 7*35*12.5mm



② X11 Cam lock 15*12mm



③ X10 Dowel 8*30mm



④ X14 Coarse screw 7*11*50mm

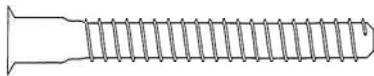

⑤ X5 Foot



⑥ X1 Lifter

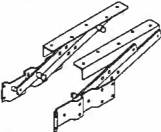

⑦ X1 Spring



⑧ X26 Wood screw 8#5/8"



⑨ X4 Bolt 2*10mm



⑩ X1 Glue



⑪ X1 Allen wrench



Attention

Some number parts listed on the instruction sheet may not be in parts bag as they may already be assembled. Carefully check parts and packing materials prior to ordering replacements.

ASSEMBLY INSTRUCTIONS

Step 1.

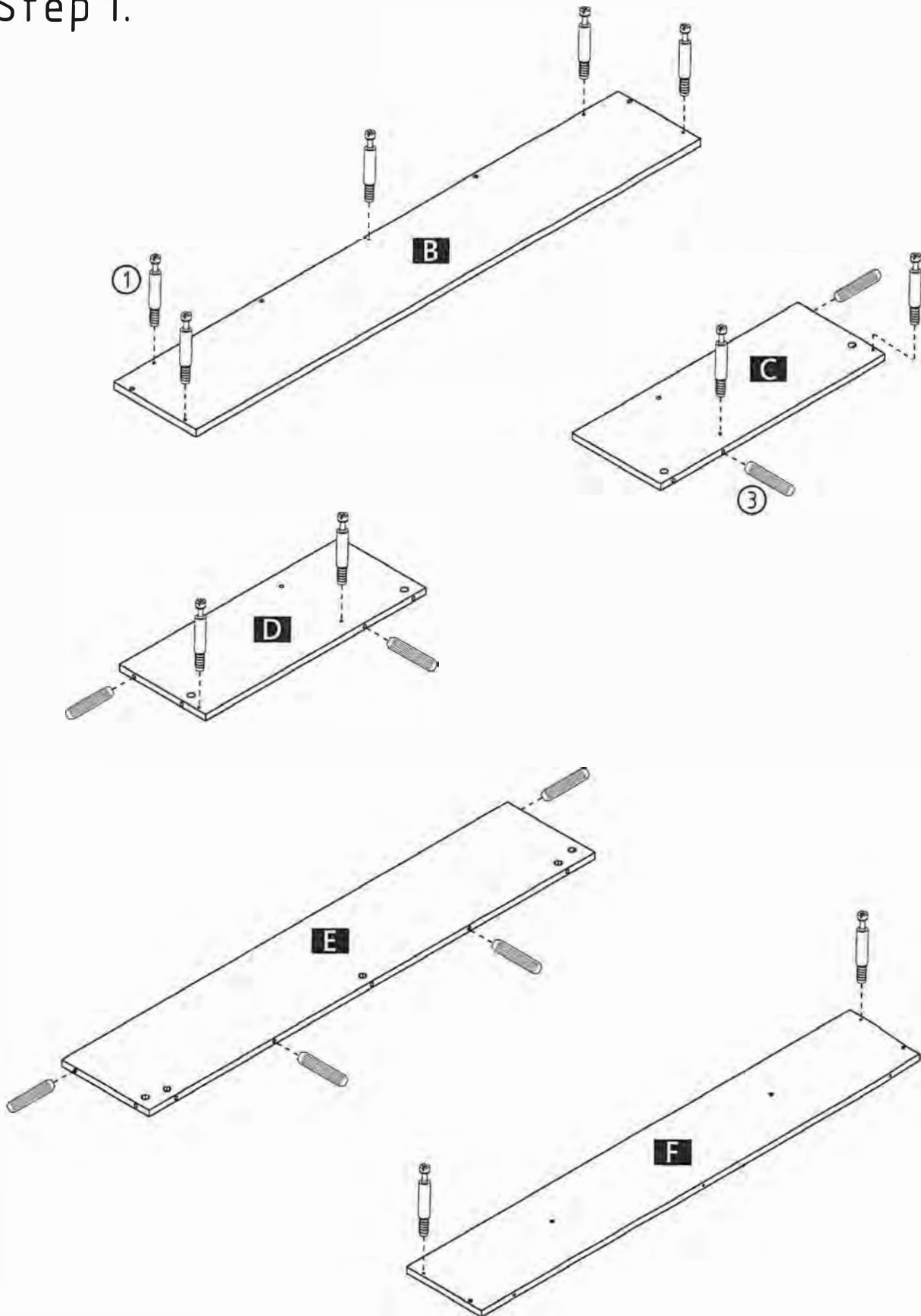

ASSEMBLY INSTRUCTIONS

Step 2.

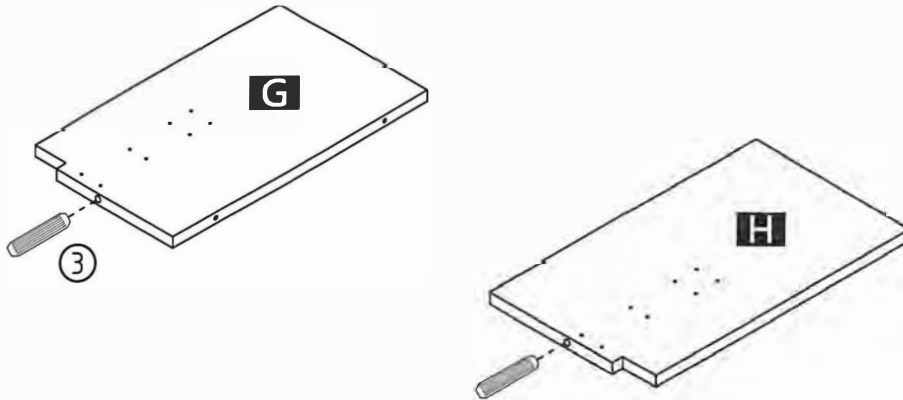

Step 3.

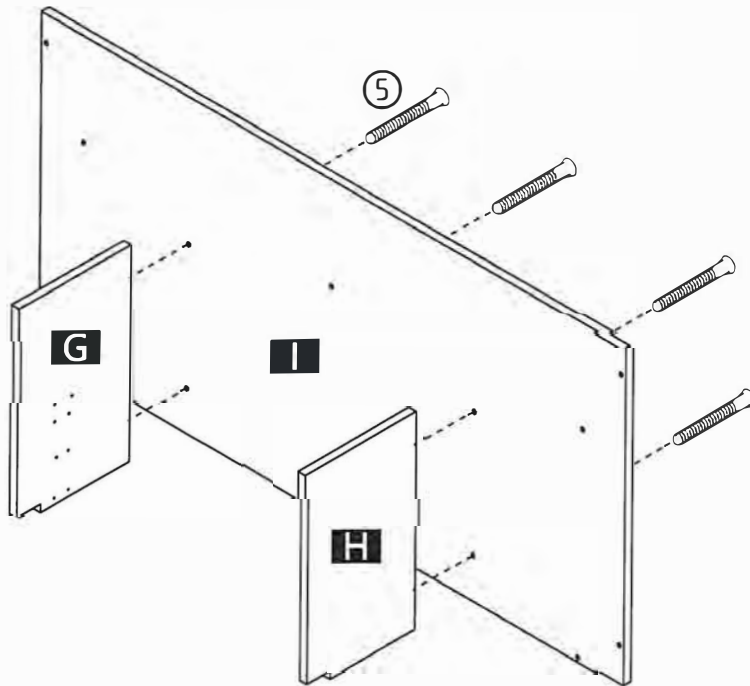

ASSEMBLY INSTRUCTIONS

Step 4.

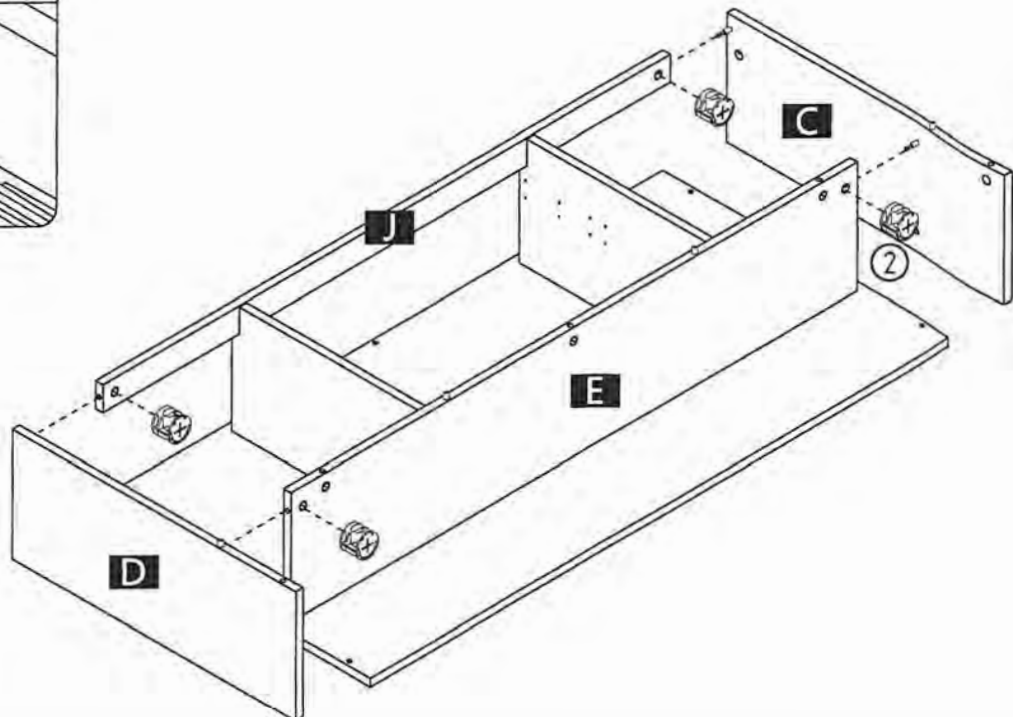
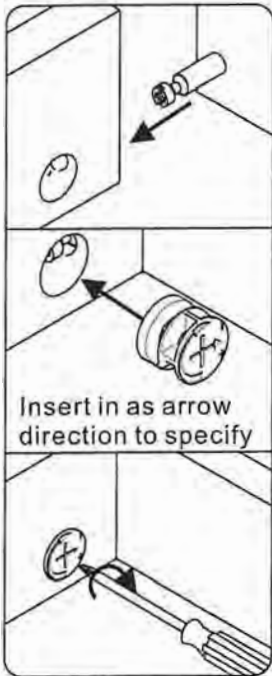
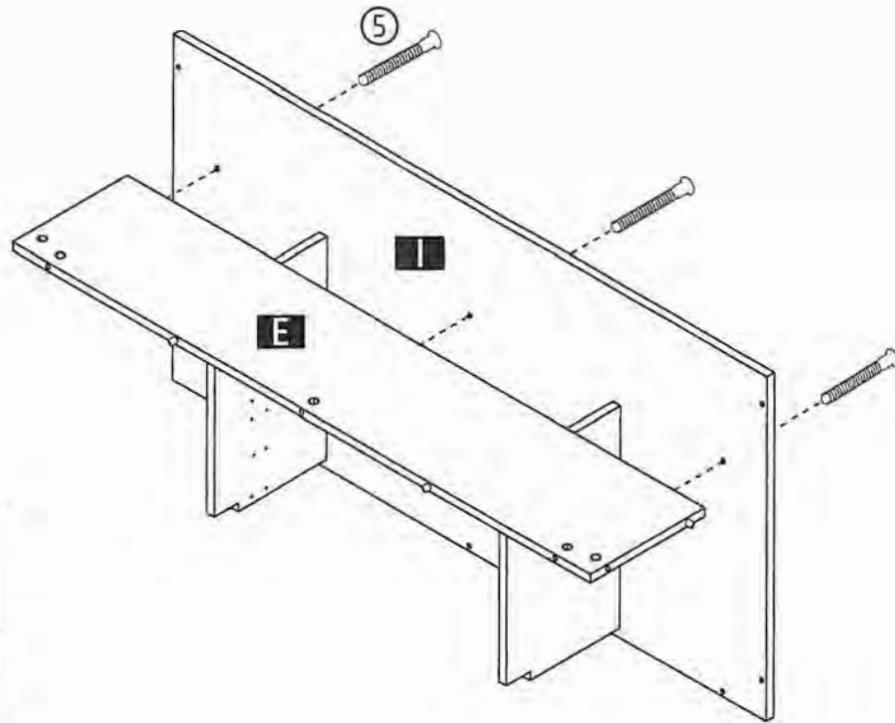

ASSEMBLY INSTRUCTIONS

Step 5.

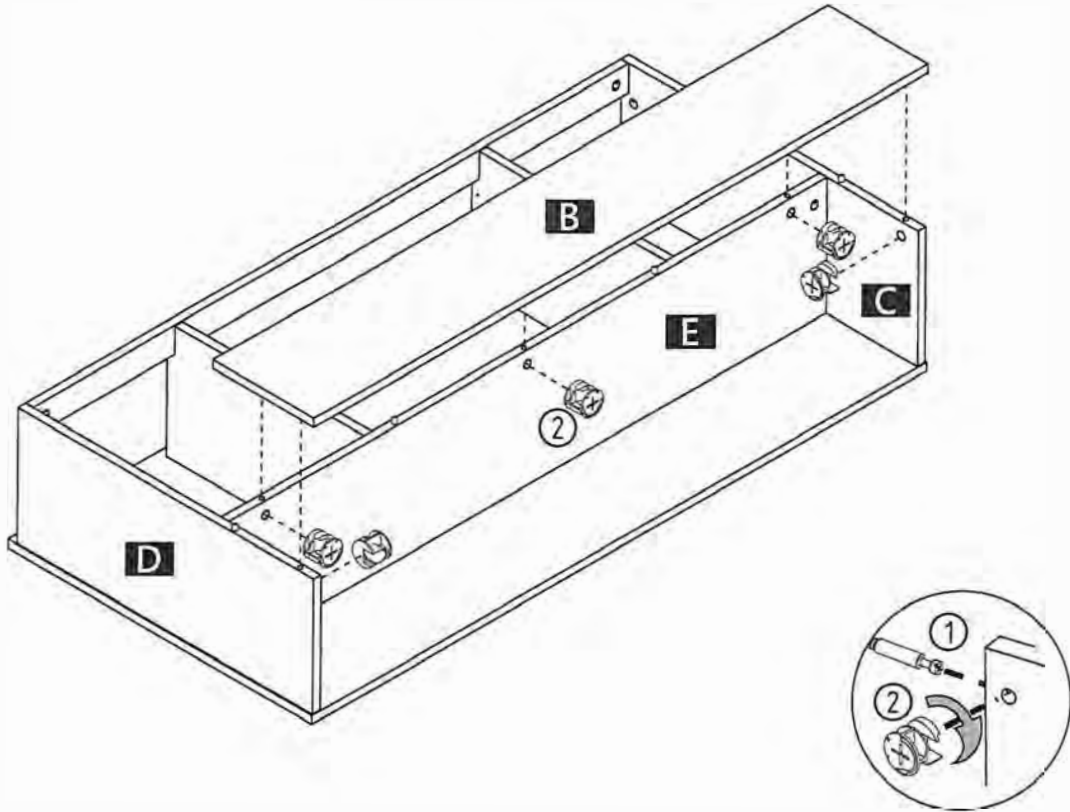

Step 6.

Align and hook the springs to the hinges.

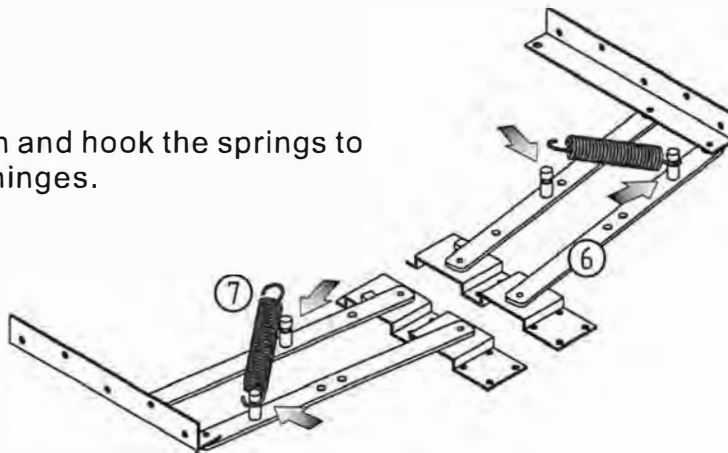

ASSEMBLY INSTRUCTIONS

Step 7.

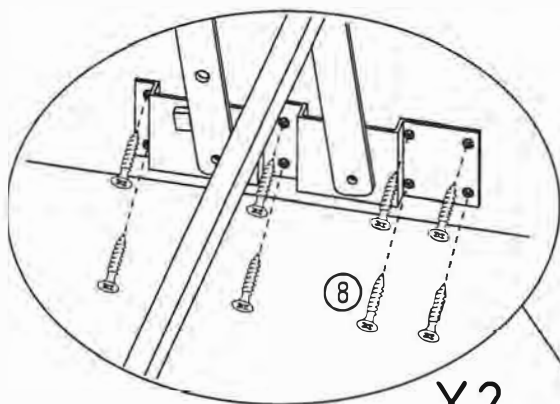
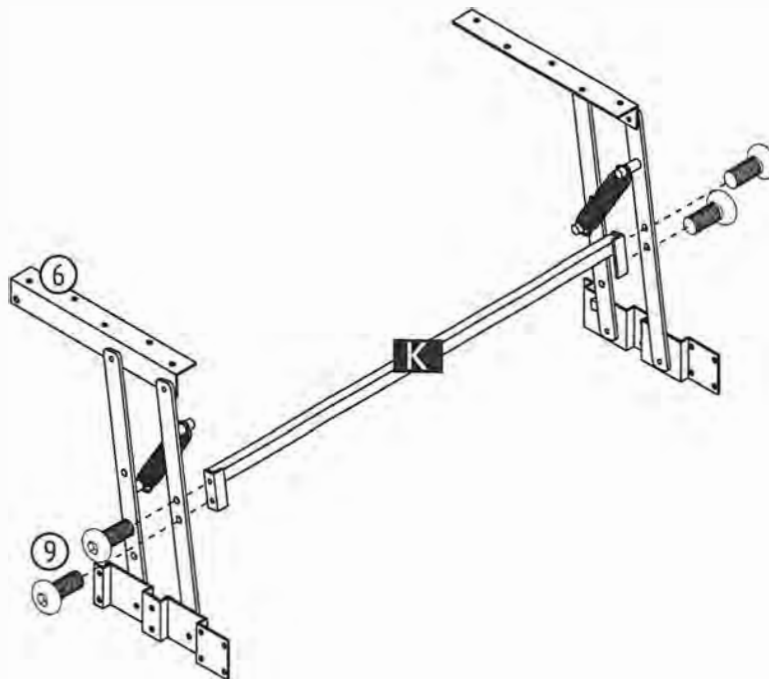

X2

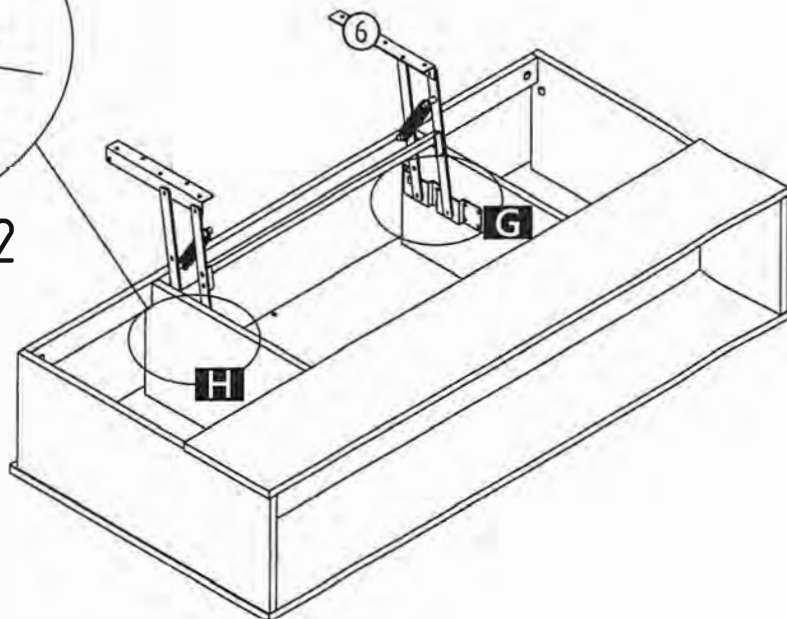

ASSEMBLY INSTRUCTIONS

Step 8.

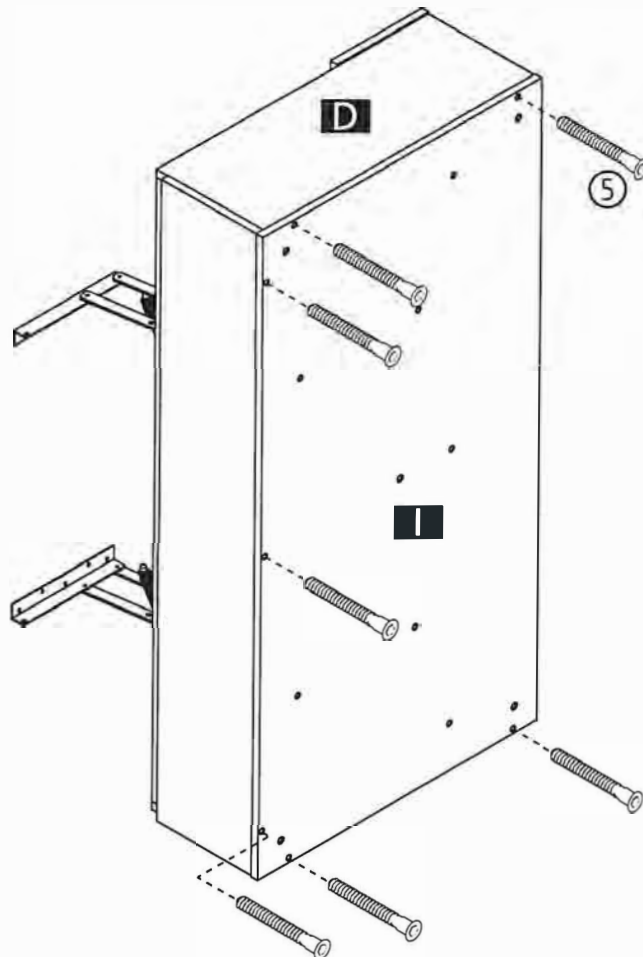
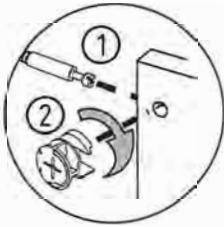
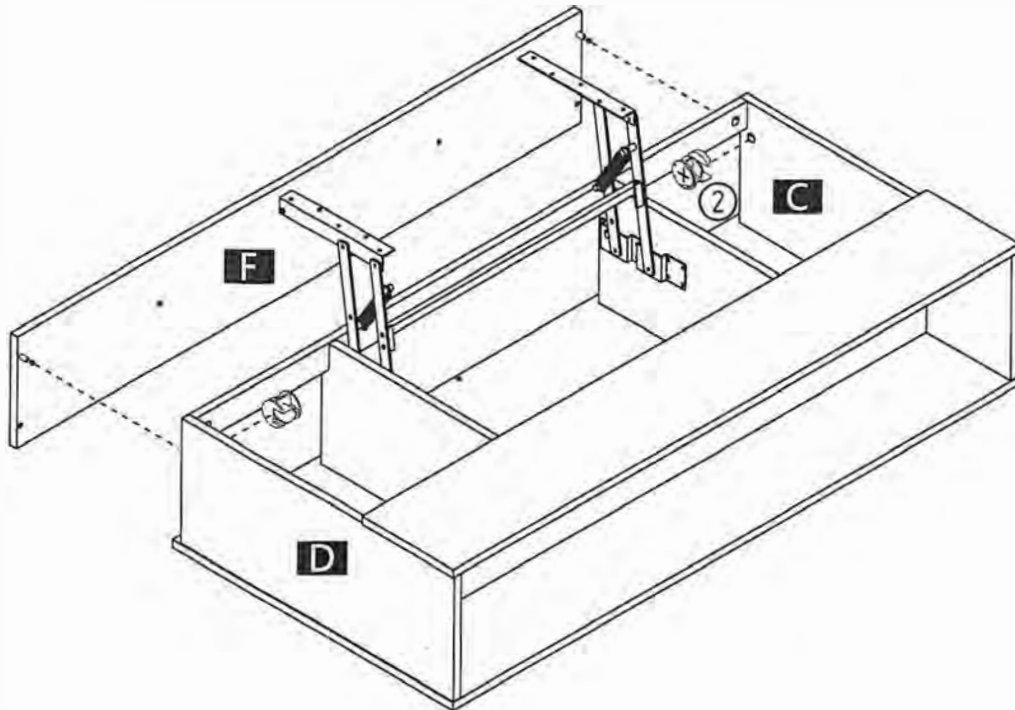

ASSEMBLY INSTRUCTIONS

Step 9.

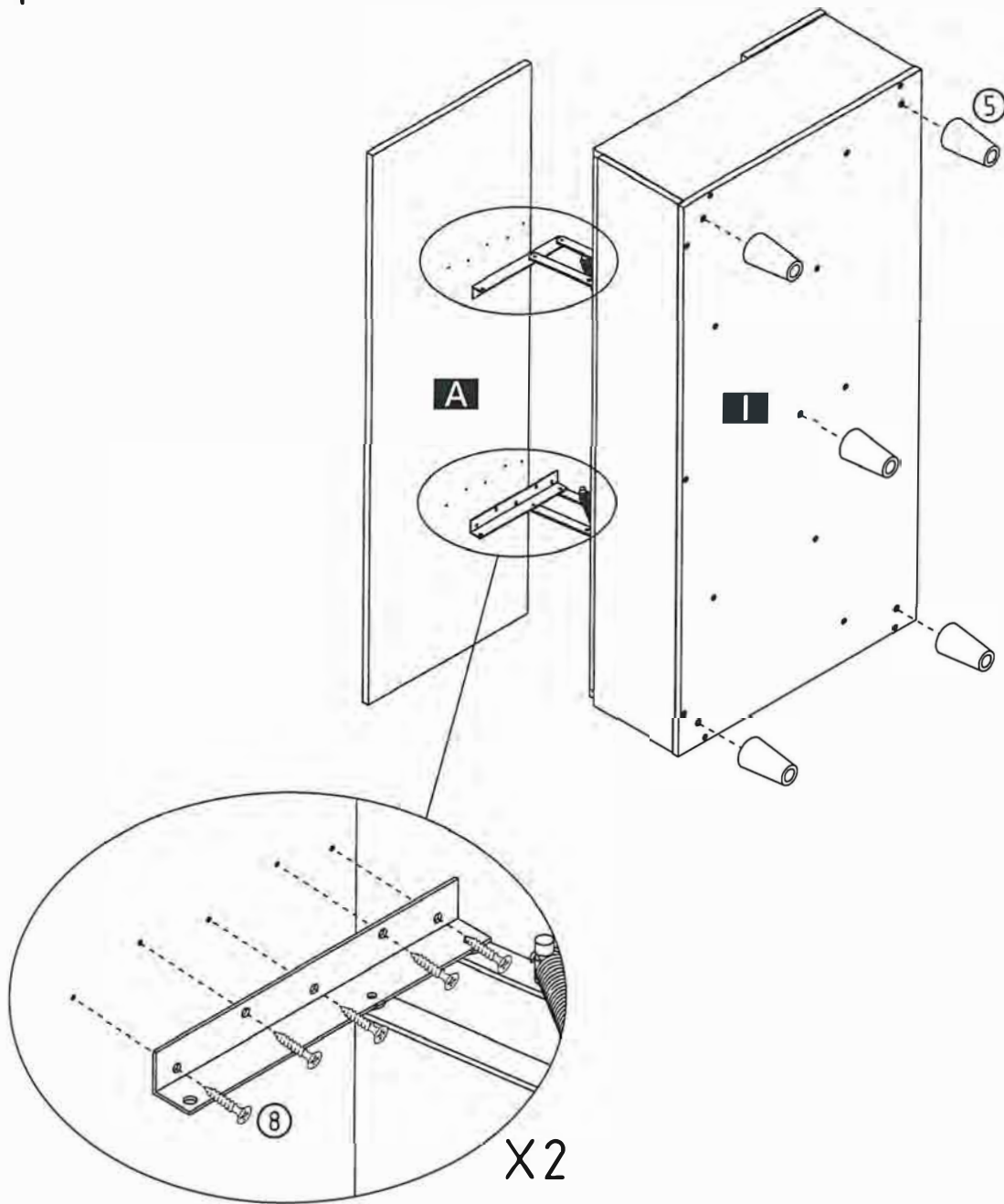

ASSEMBLY IS COMPLETED.

Make sure the product is rested on a flat surface and does not feel loose or wobbly. If it does, double check that the bolts/screws are secured and properly tightened.