

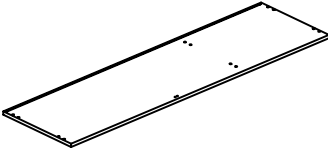

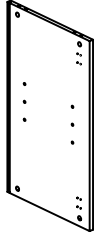

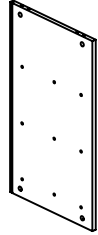

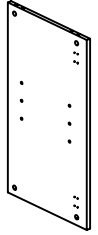



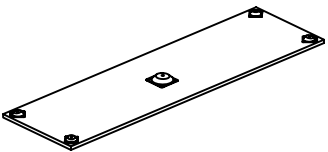
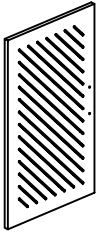
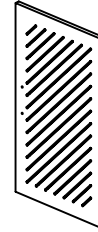
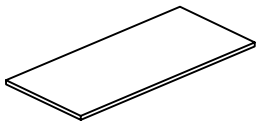
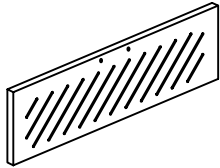
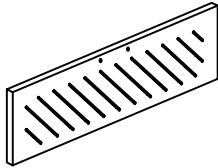
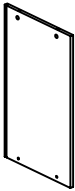
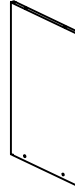
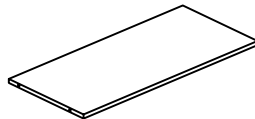
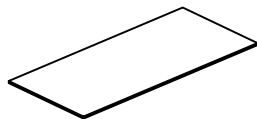
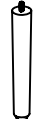

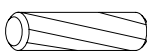
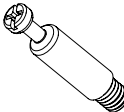
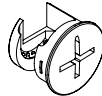

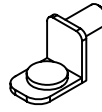
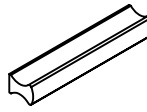
ASSEMBLY INSTRUCTION

<p>A</p>  <p>1 pc</p>	<p>B</p>  <p>1 pc</p>	<p>C</p>  <p>1 pc</p>	<p>D</p>  <p>1 pc</p>	<p>E</p>  <p>3 pcs</p>	<p>F</p>  <p>2 pcs</p>
<p>G</p>  <p>1 pc</p>	<p>H</p>  <p>1 pc</p>	<p>I</p>  <p>1 pc</p>	<p>J</p>  <p>1 pc</p>	<p>K</p>  <p>2 pcs</p>	<p>L</p>  <p>1 pc</p>
<p>M</p>  <p>3 pcs</p>	<p>N</p>  <p>3 pcs</p>	<p>O</p>  <p>3 pcs</p>	<p>P</p>  <p>3 pcs</p>	<p>Q</p>  <p>1 pc</p>	<p>R</p>  <p>4 pcs</p>
<p>1</p>  <p>12 pcs</p>	<p>2</p>  <p>24 pcs</p>	<p>3</p>  <p>24 pcs</p>	<p>4</p>  <p>2 pcs</p>	<p>5</p>  <p>4 pcs</p>	<p>6</p>  <p>5 pcs</p>
<p>7</p>  <p>10 pcs</p>	<p>8</p>  <p>12 pcs</p>	<p>9</p>  <p>4*12mm 12 pcs</p>	<p>10</p>  <p>4 pcs</p>	<p>11</p>  <p>4*12mm 24 pcs</p>	<p>12</p>  <p>6 pcs</p>
<p>13</p>  <p>4*12mm 24 pcs</p>	<p>14</p>  <p>4*25mm 12 pcs</p>	<p>15</p> 			

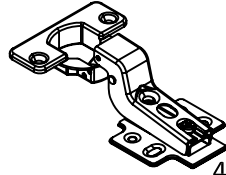
Step 1

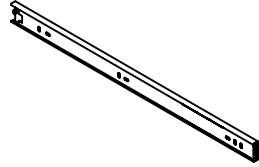

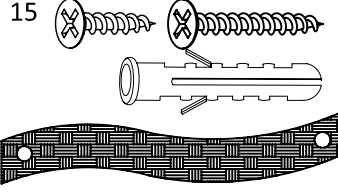
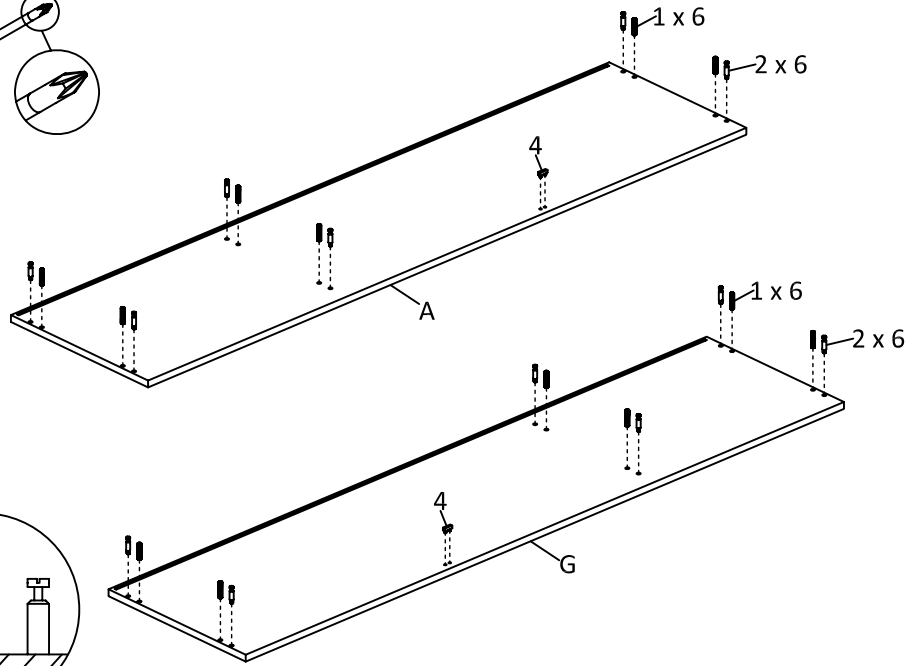
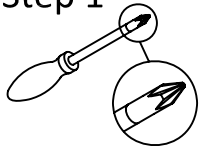
Step 2

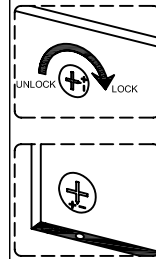
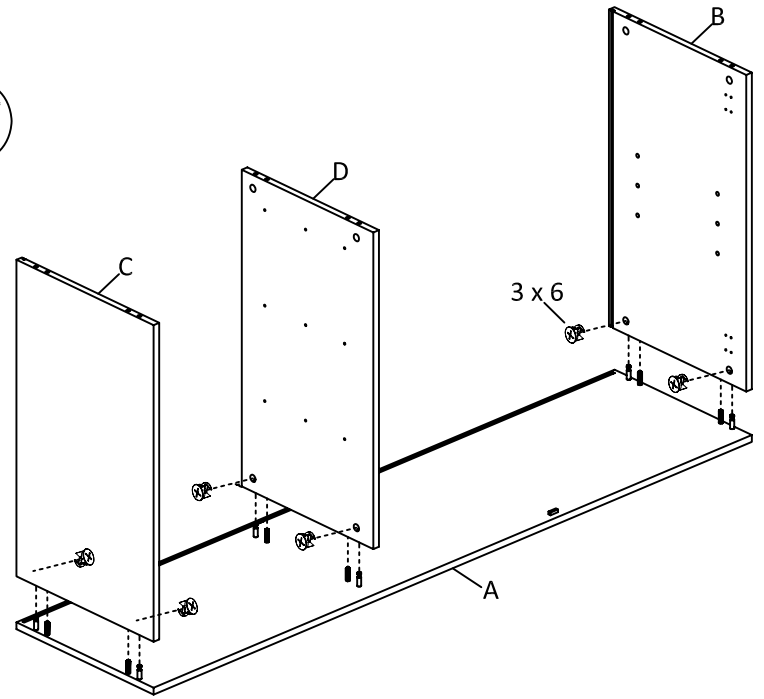
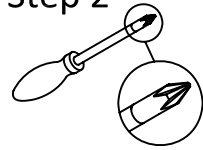

Proper orientation of CAM LOCK

Step 3

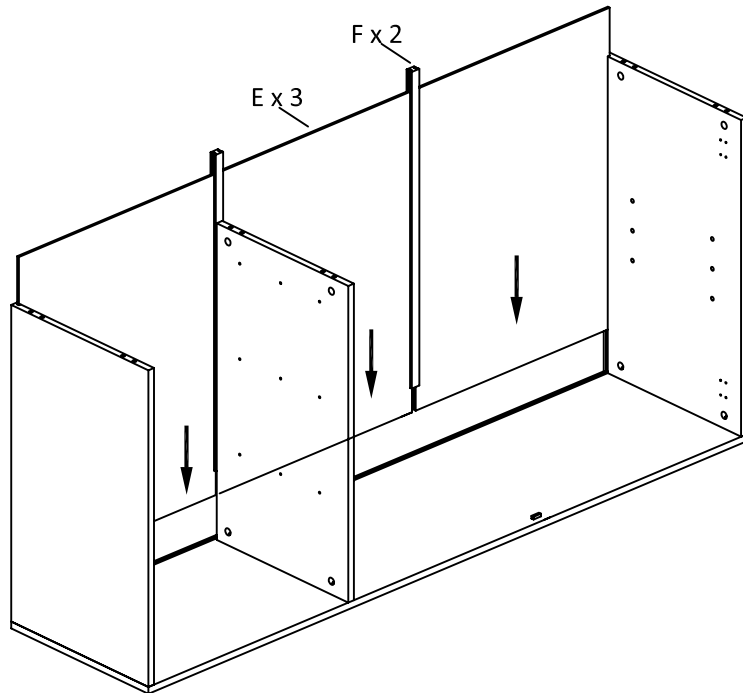

Step 4

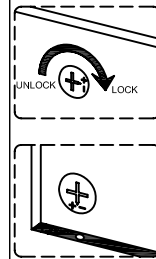
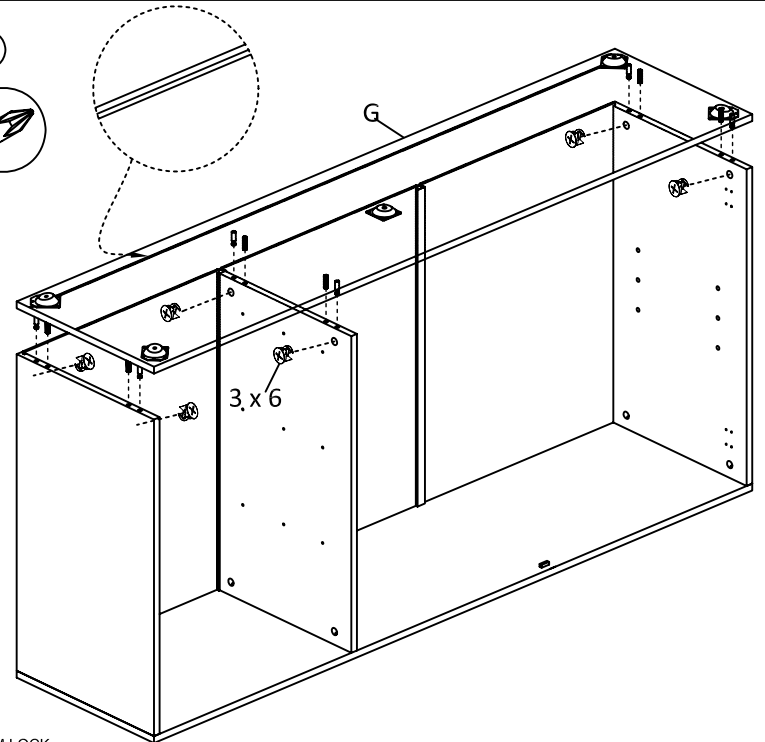
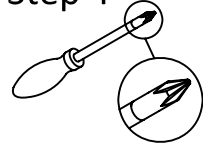

Proper orientation of CAM LOCK

Step 5

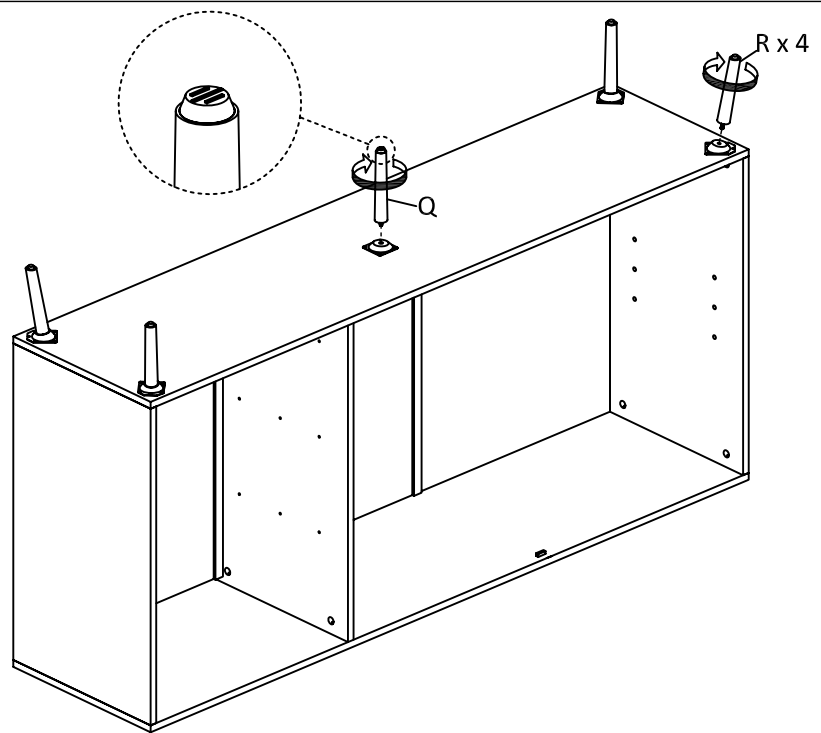

Step 6

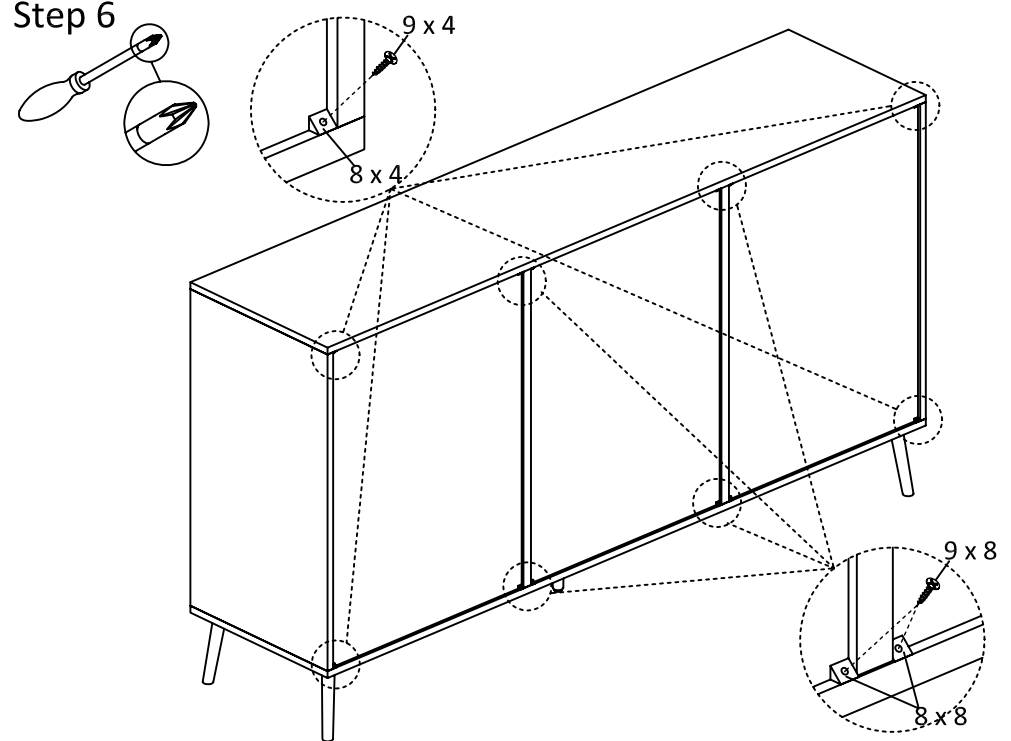

Step 7

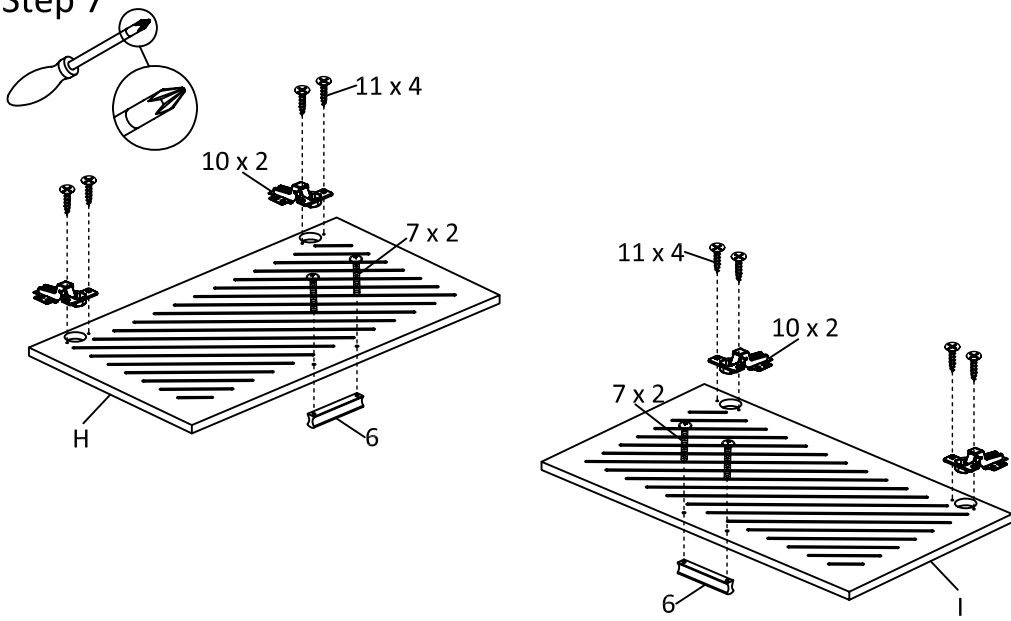

Step 8

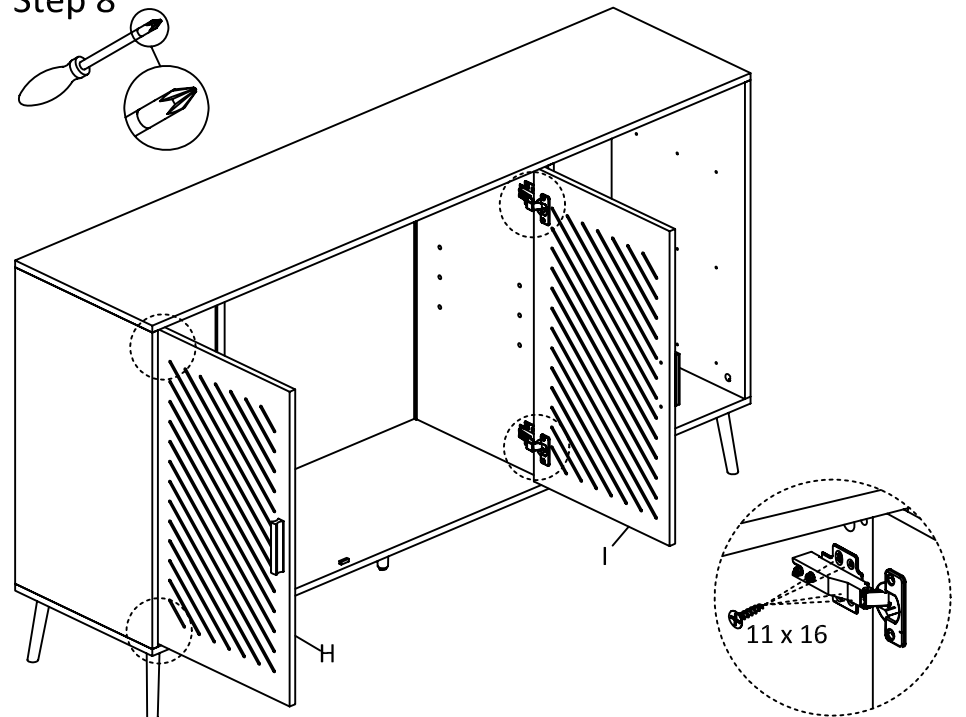

Step 9

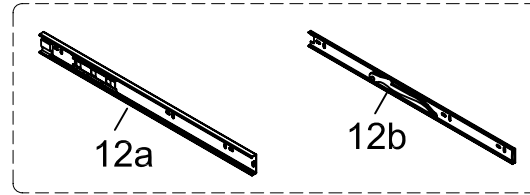
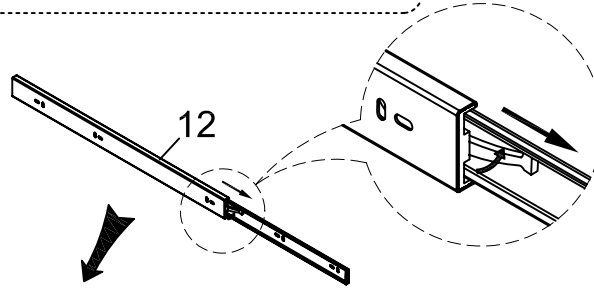
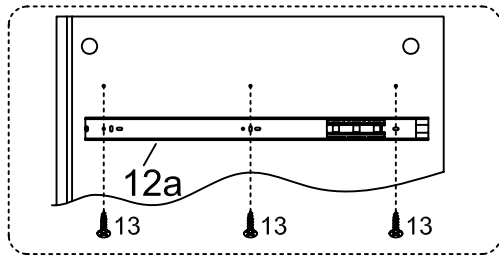
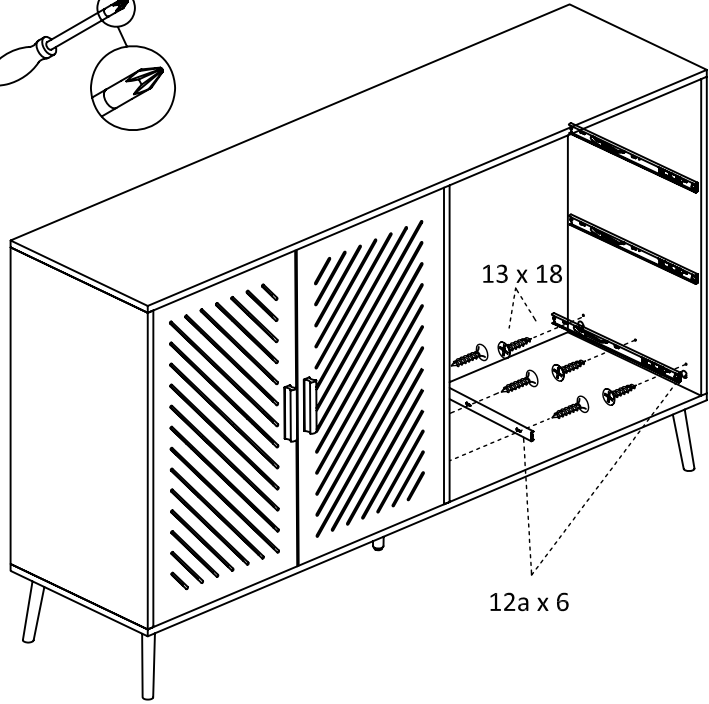
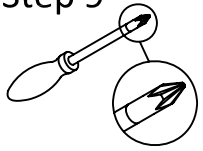

Step 10

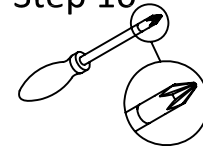

x 3

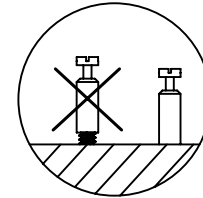
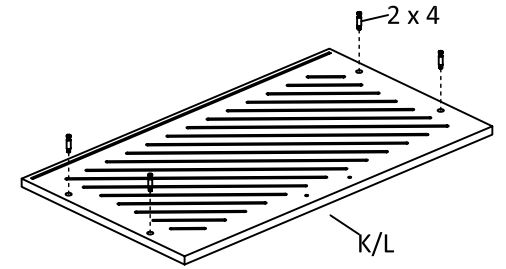

Step 11

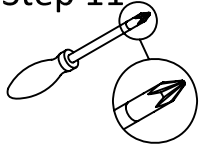

x 3

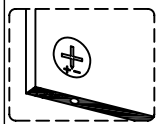
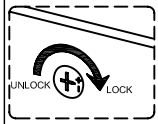
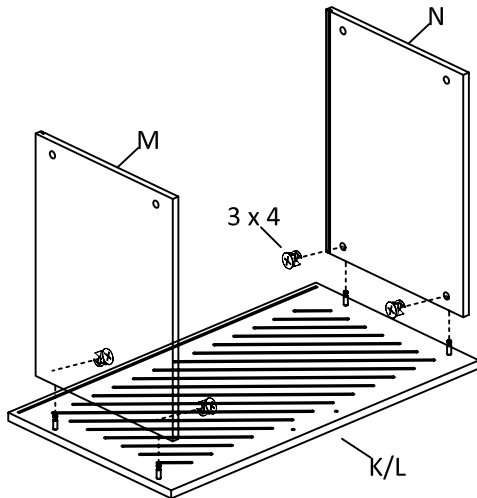

Proper orientation of CAM LOCK

Step 12

x 3

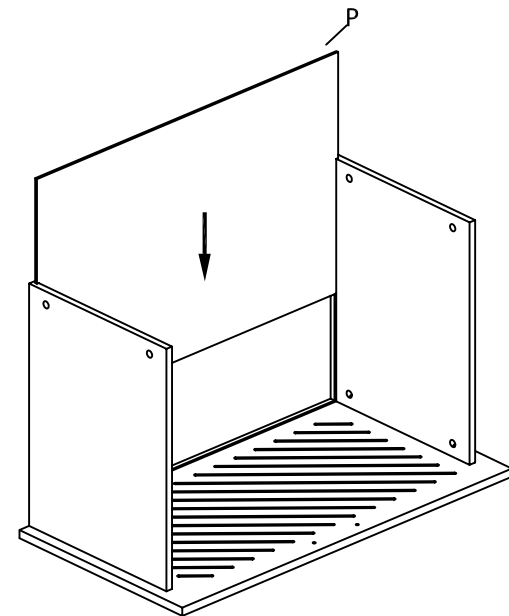

Step 13

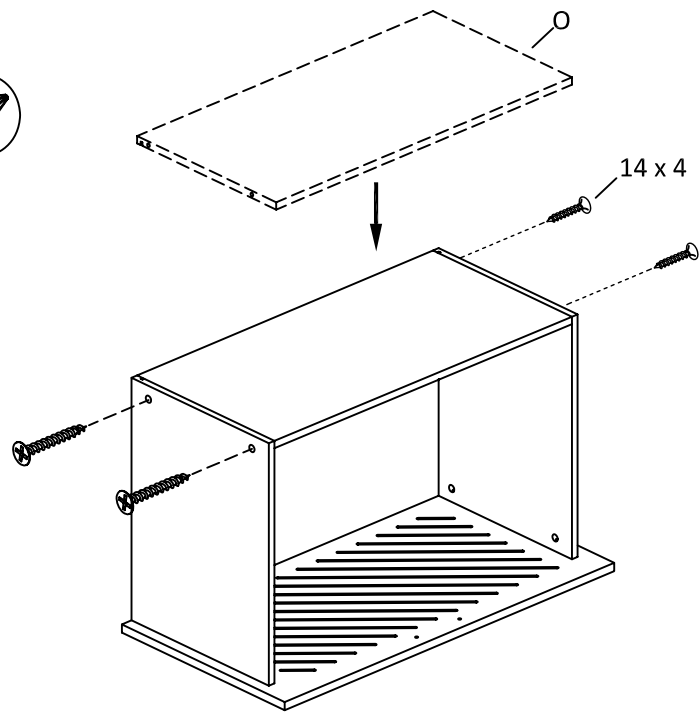
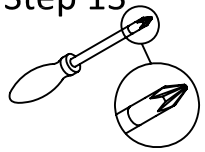

x 3

Step 14

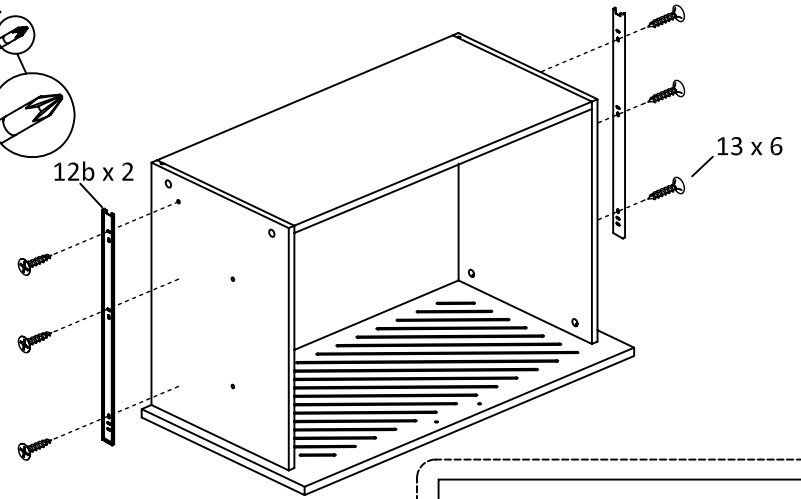
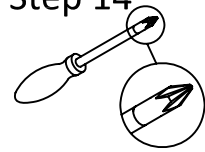

x 3

Step 15

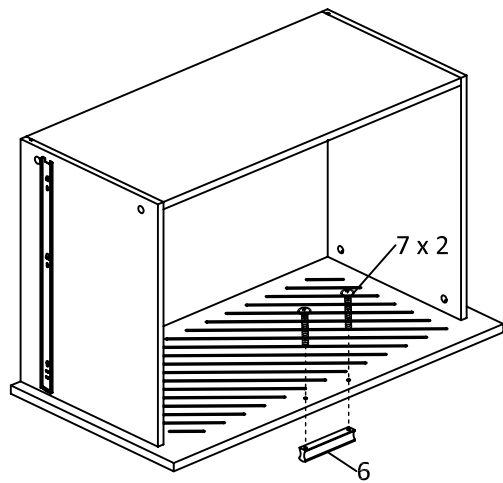
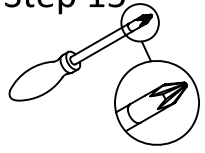

x 3

Step 16

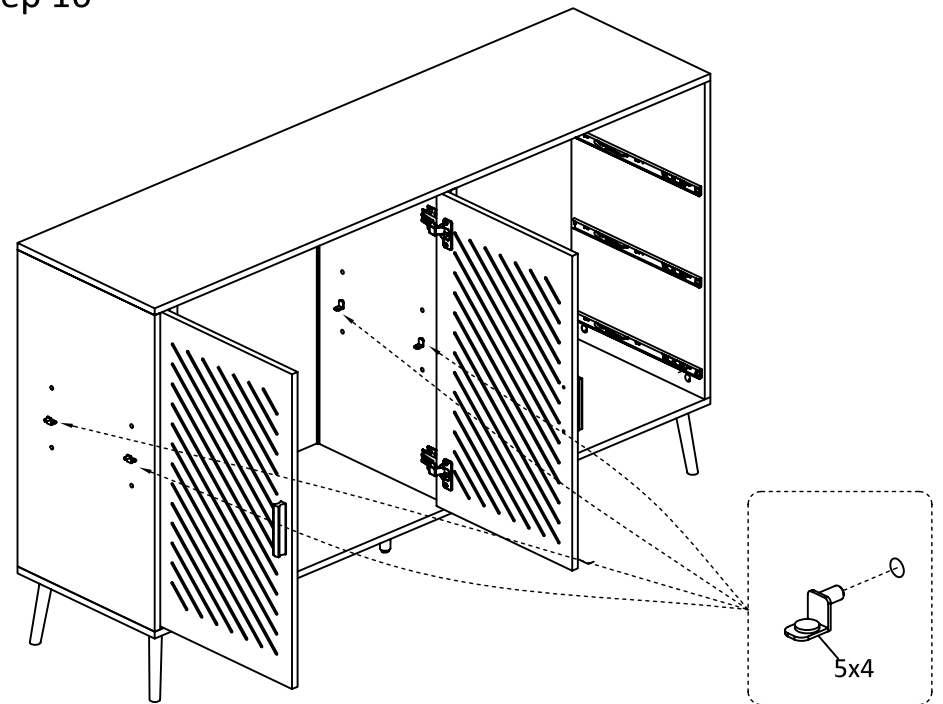

5x4

Step 17

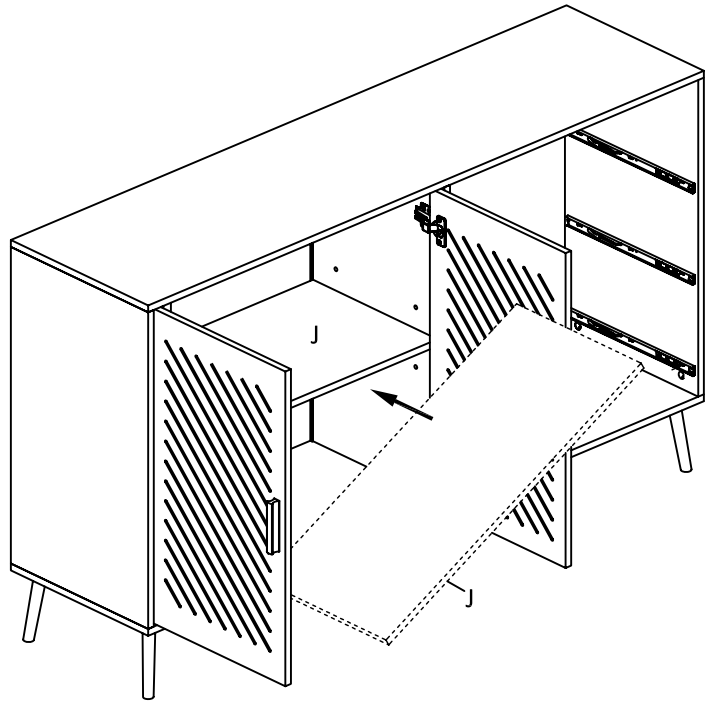

Step 18

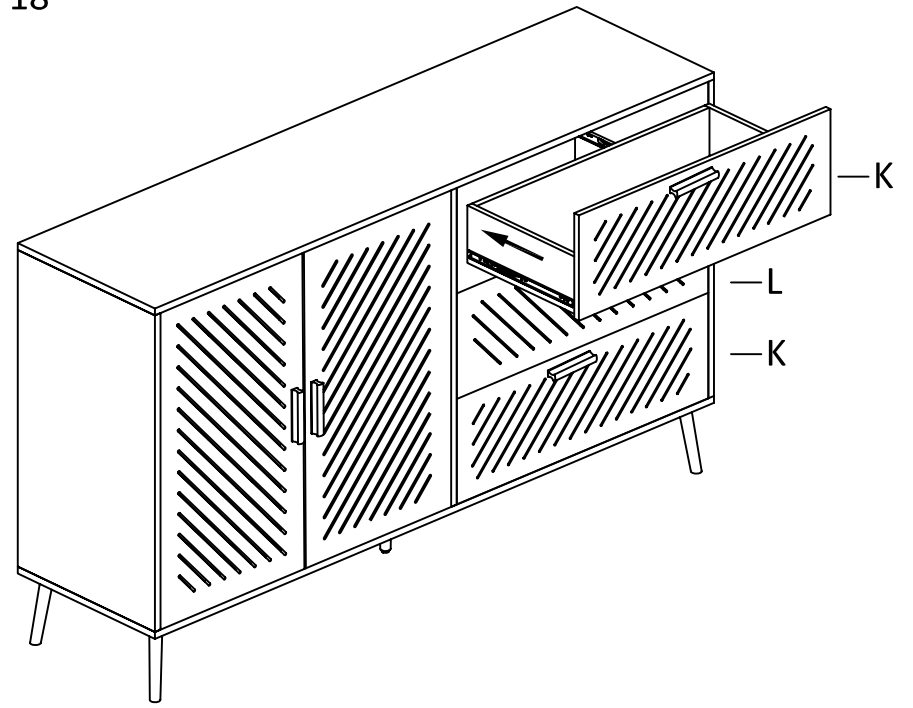

Step 19

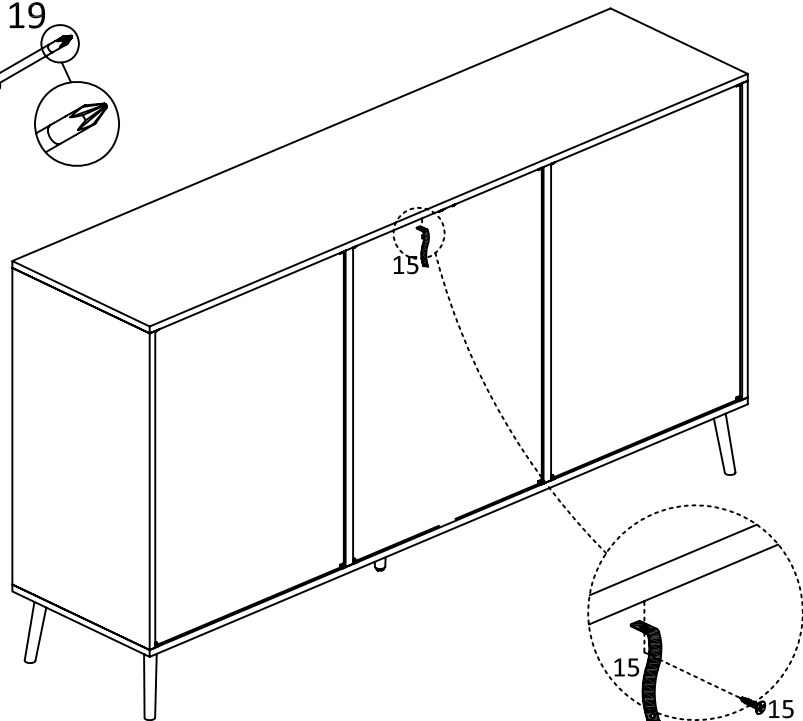
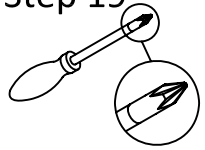

Step 20

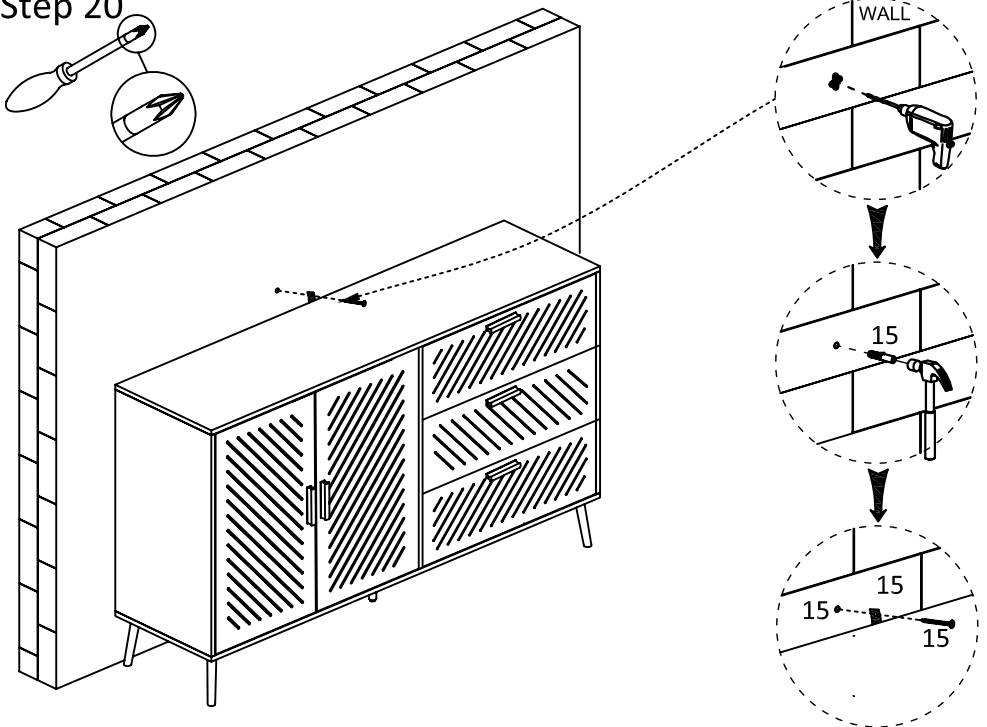
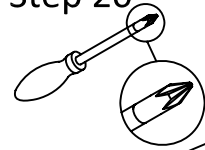

Step 21

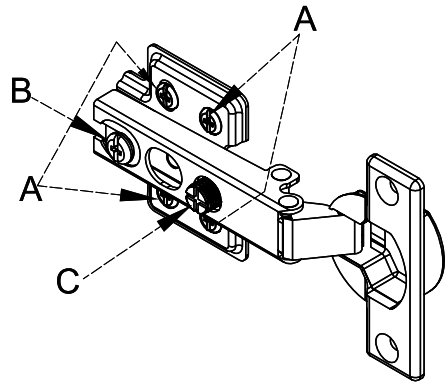

Step 22

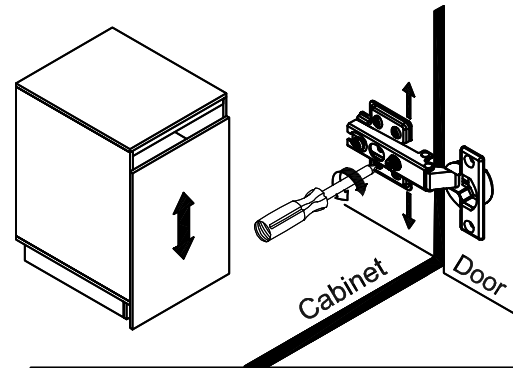

To adjust the vertical height.
Loosen the four screws "A" on both hinges. Two of them are usually in slotted holes which allows you to adjust up or down by a few mm. Then tighten back up.

Step 23

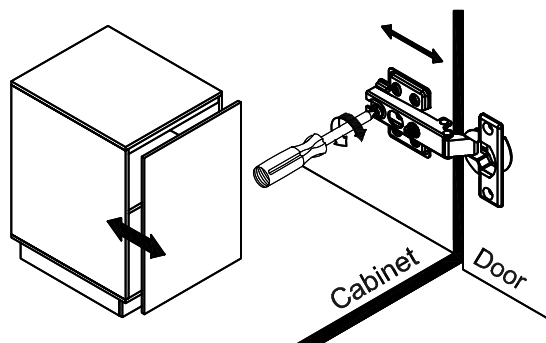

To adjust depth.
Loosen screw "B" and adjust door, if the door cannot be adjusted, please loosen screw "C", then try again. Tighten screw "B" and "C"

Step 24

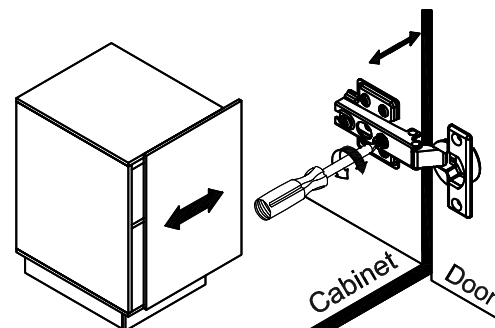

To adjust side ways.
Turning the screw "C" on BOTH hinges on each door.