

Installation & Assembly

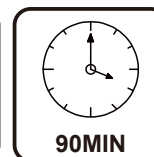
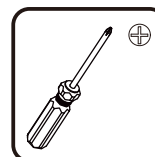
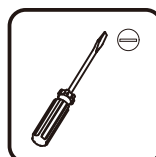
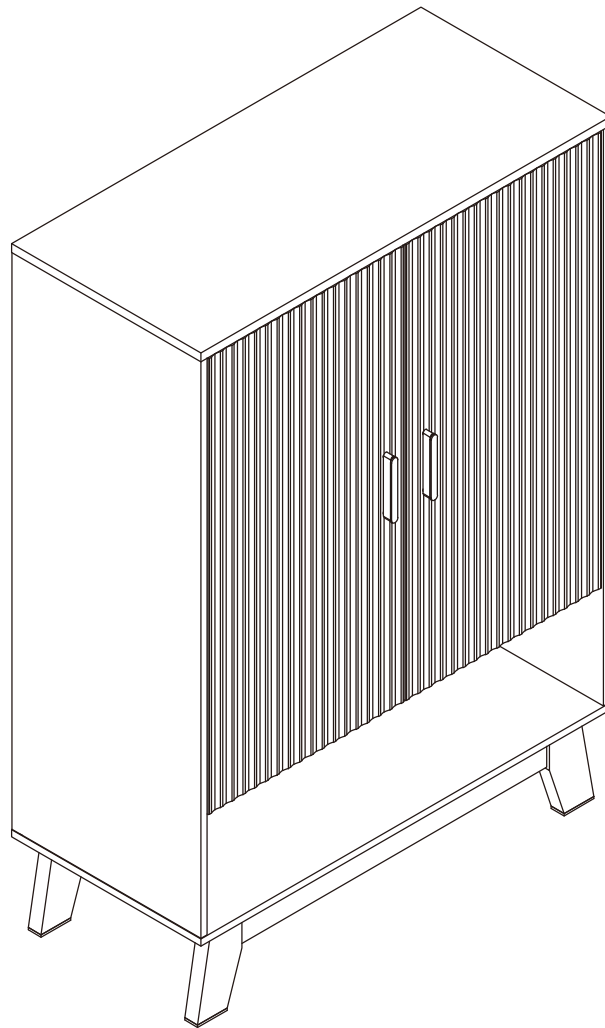

EN_IMPORTANT, RETAIN FOR FUTURE REFERENCE: READ CAREFULLY.

. THANK YOU FOR PURCHASE! .

FREE REPLACEMENT PARTS AVAILABLE!

If you're experiencing any issues—whether due to shipping, assembly, or any other reason
—we're here to help.
For any damaged or missing components, we're happy to provide FREE replacement parts.

WANT TO CONTACT US

- ▶ Go to “Your Orders” and locate your furniture order.
- ▶ Click on “Get Help with Order” to send us a message directly.

Our customer support team is ready to assist you and we will respond within
12-24 HOURS to resolve your concerns quickly!

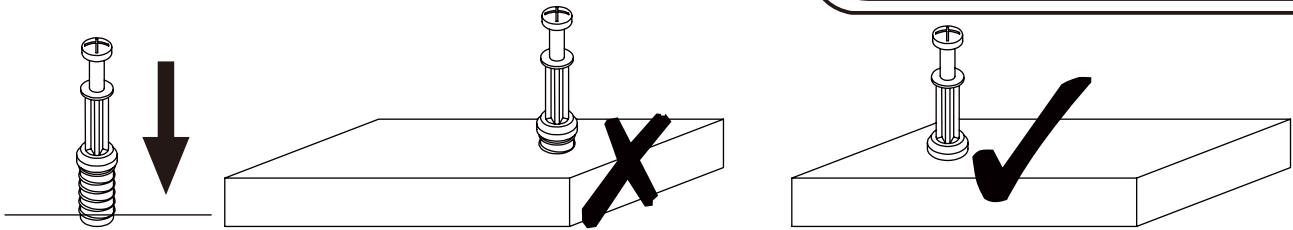

EN_QUICKFIT: Tighten quickfit until shoulder is flush with panel. Do not overtighten or undertighten.

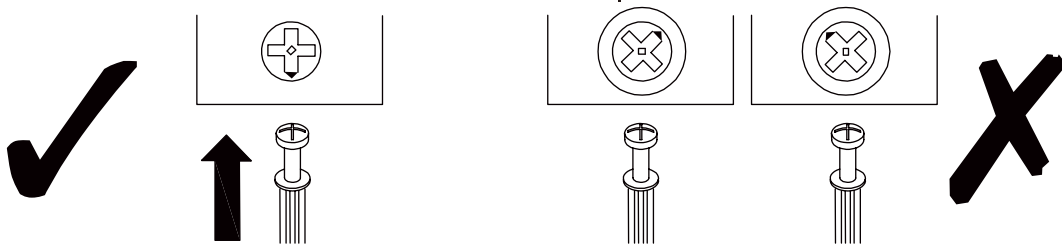

EN_CAM LOCK: When fitting cam lock, ensure starting position is correct before you insert connecting quickfit.

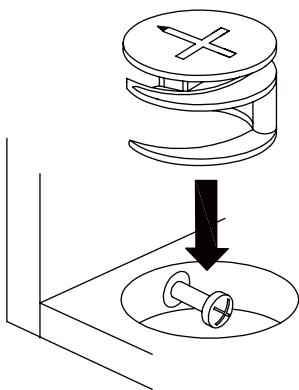



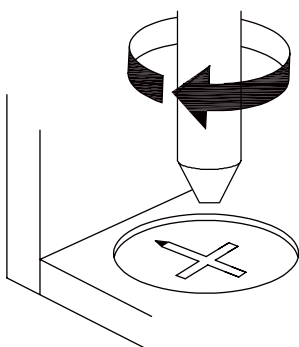



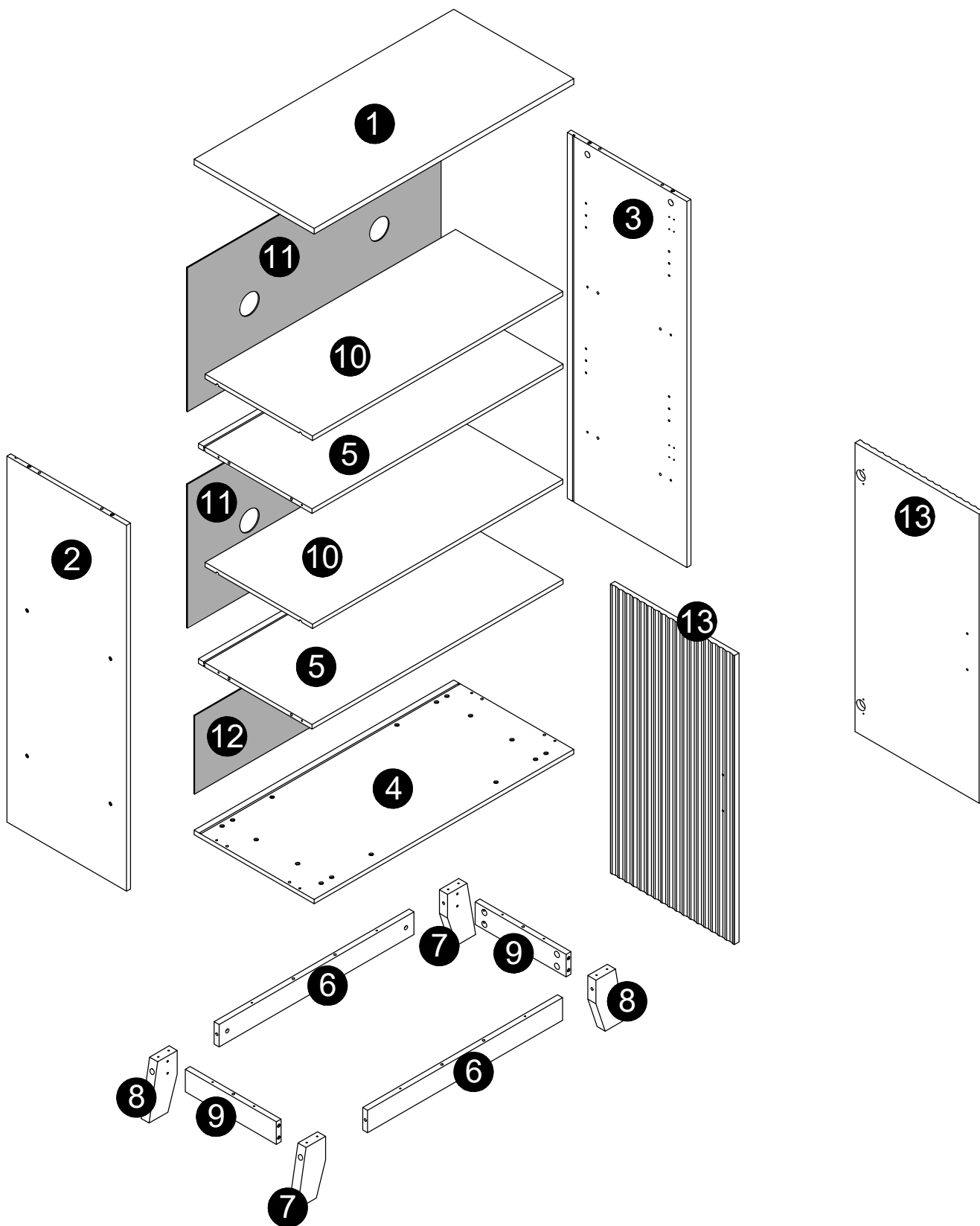

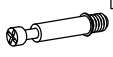









EN_Quickfit head should be in the centre of the cam lock when the two panels are joined.
Cam lock should be inserted before quickfit.

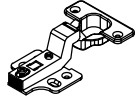

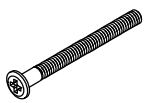
EN_Turn cam lock clockwise to tighten.

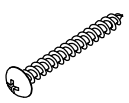

 A x12 Ø6x35mm +1(spare)	 B x12 Ø15x10mm +1(spare)	 C x22 Ø6x30mm +2(spare)	 D x14 Ø4x35mm +1(spare)	 E x26 Ø3.5x12mm +3(spare)	 F x2
 G1 Ø3x16mm +1(spare)	 H x8 +1(spare)	 I x28 Ø20mm +2(spare)	 J x2 Ø4x14mm	 K x2	 L x2 Ø6x30mm
 M x4 Ø26mm	 N x4	 O x4 Ø6x70mm	 P x4 Ø10x10mm	 Q x16 Ø4x30mm +2(spare)	 R x1

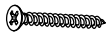
 C x4	 D x4
--	--

01

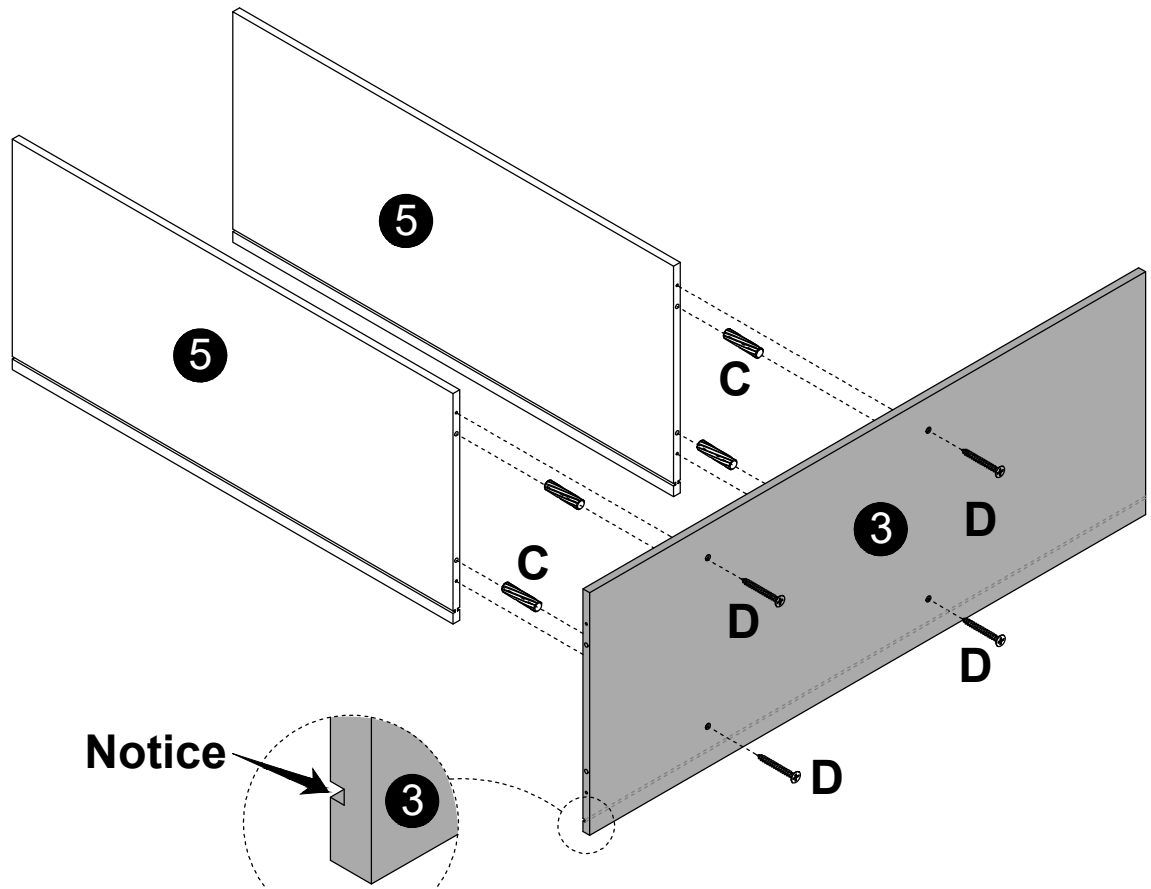

C x4

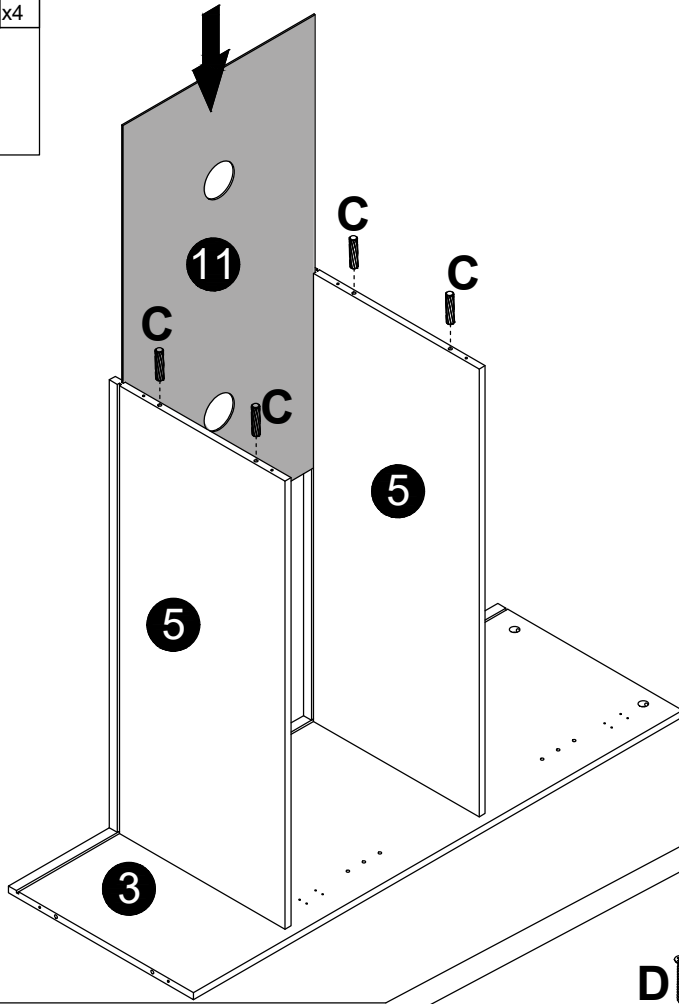

D x4

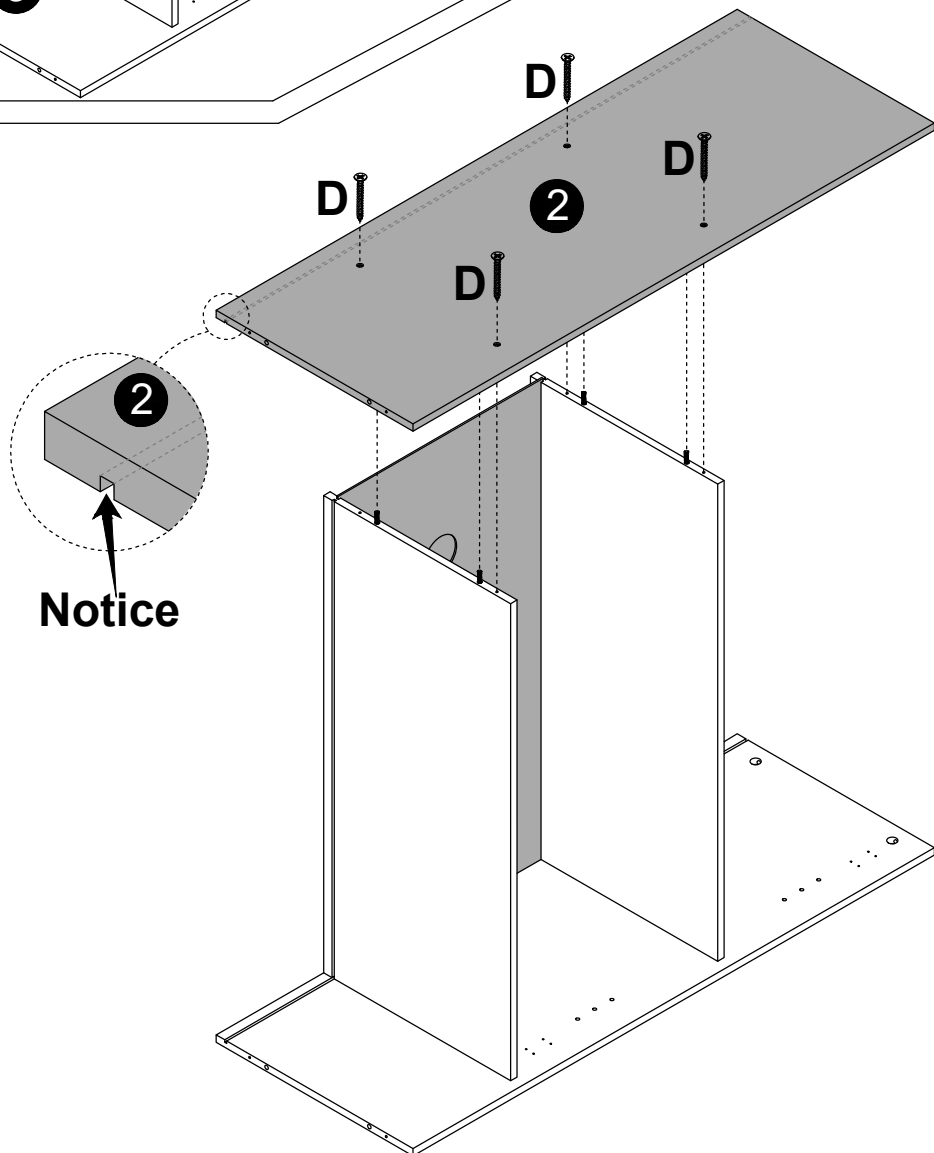

C x4



Note: At least two people are required for this step.

90°

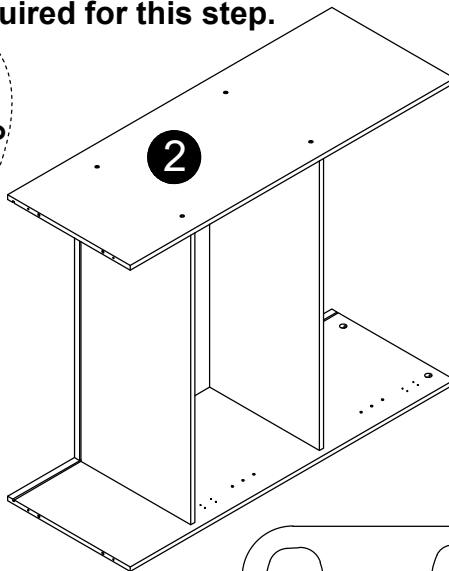
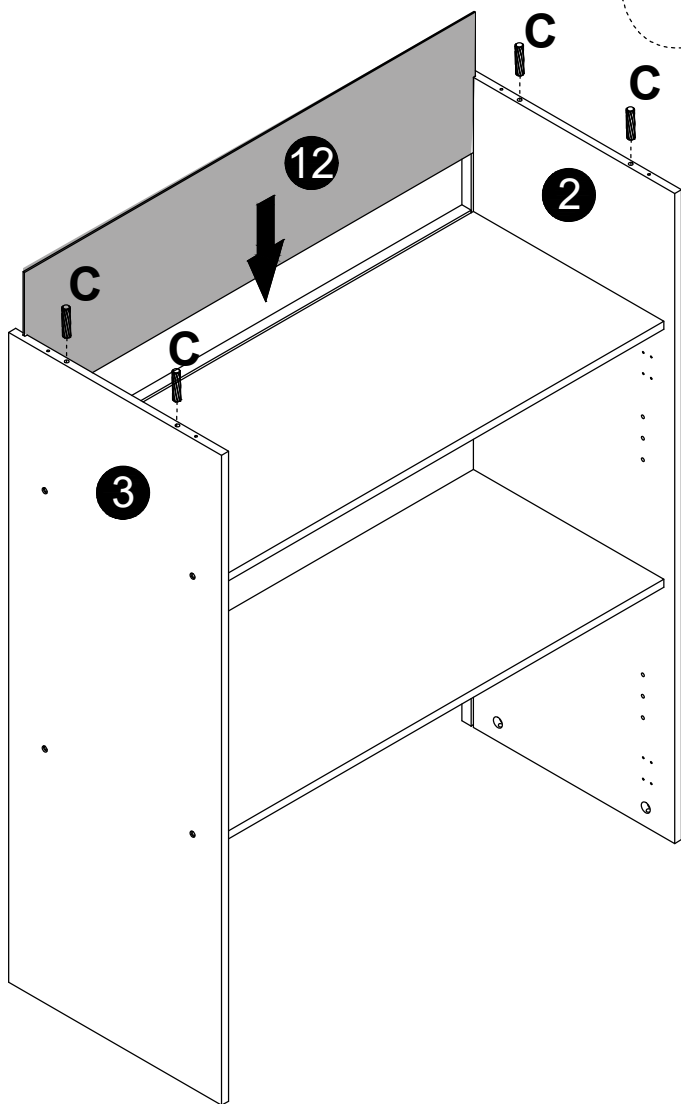

A x8

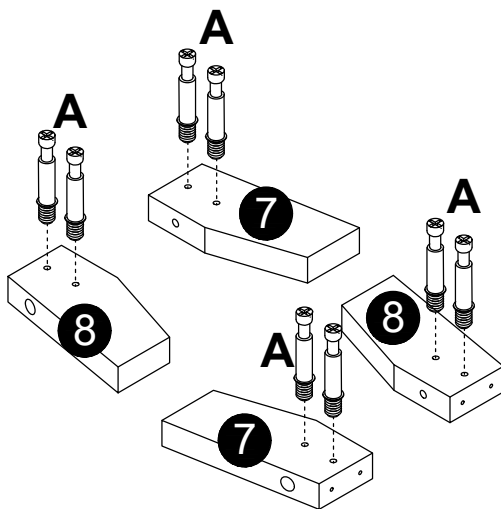

B x8



06

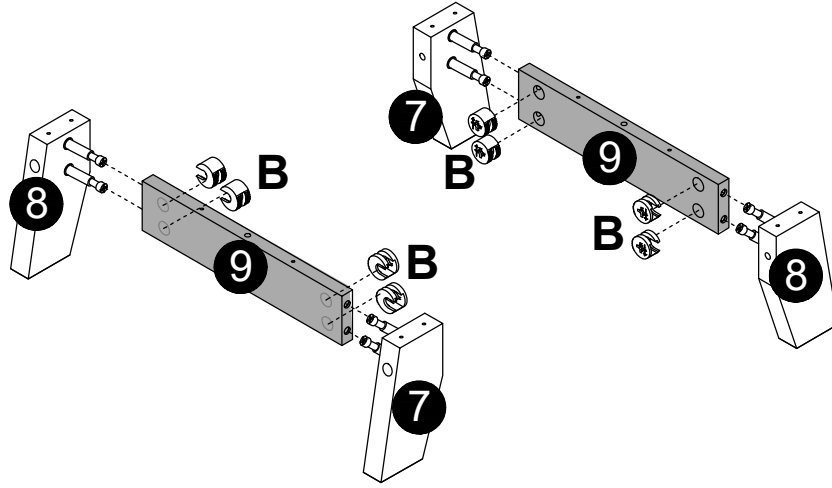

O x4

Ø6x70mm

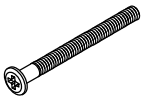

P x4

Ø10x10mm



07

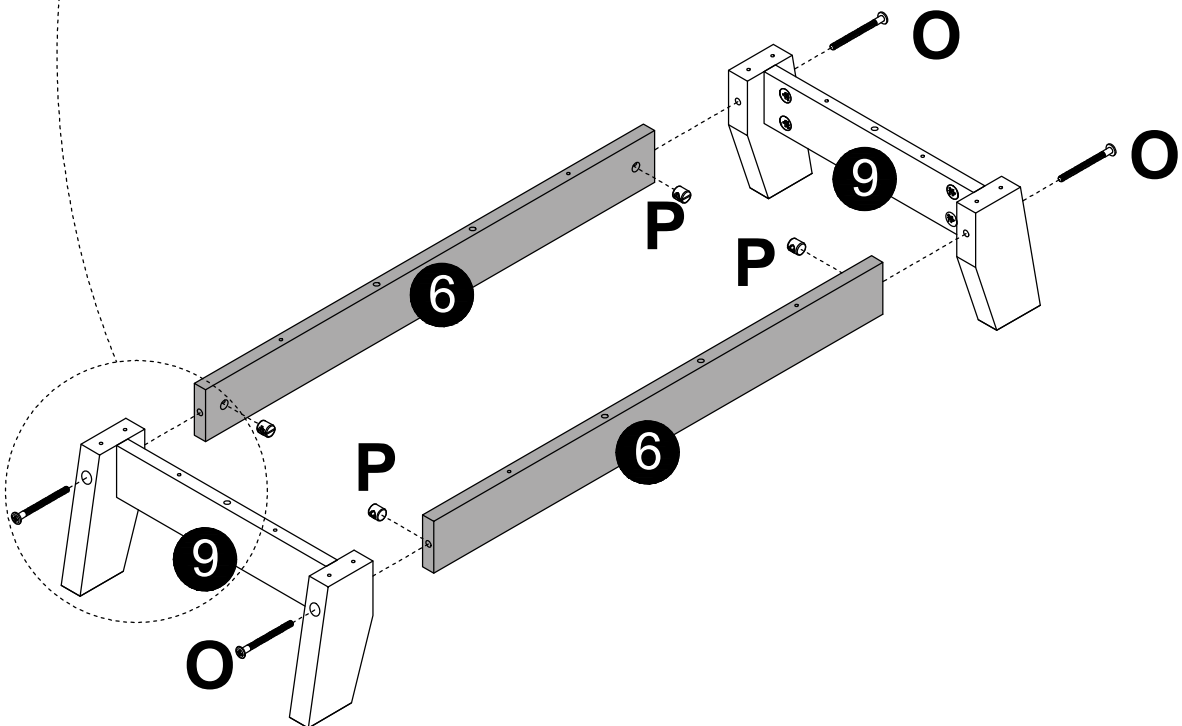
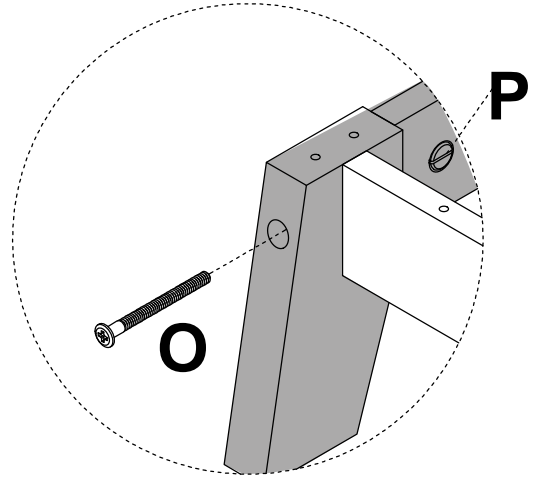
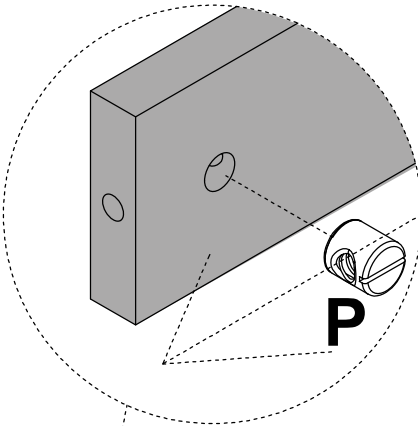

C x6

08

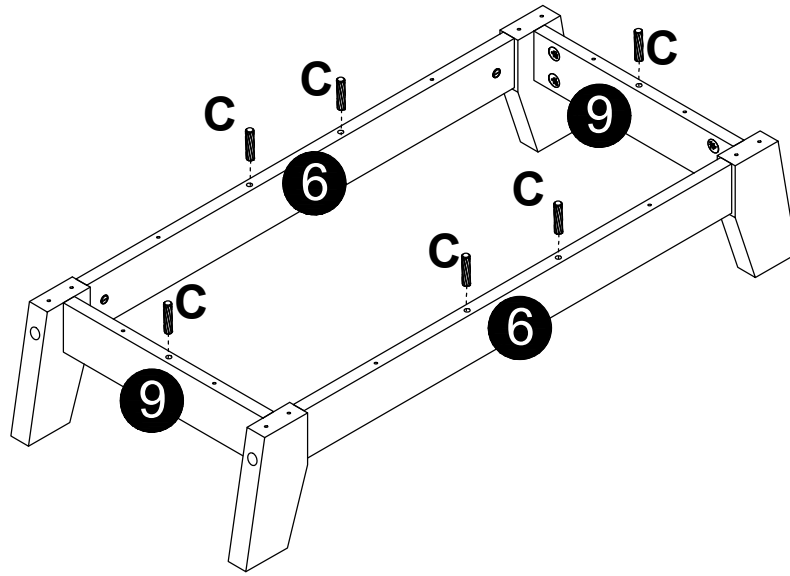

Q x16

09



Notice

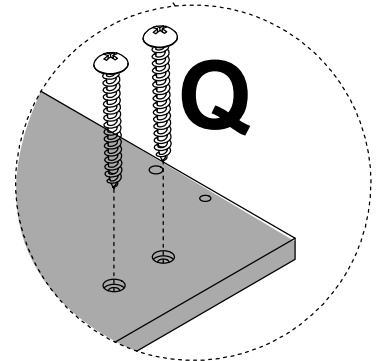
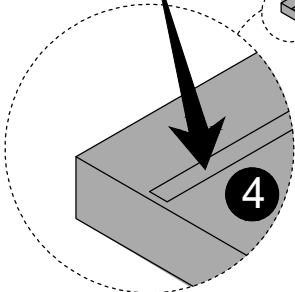
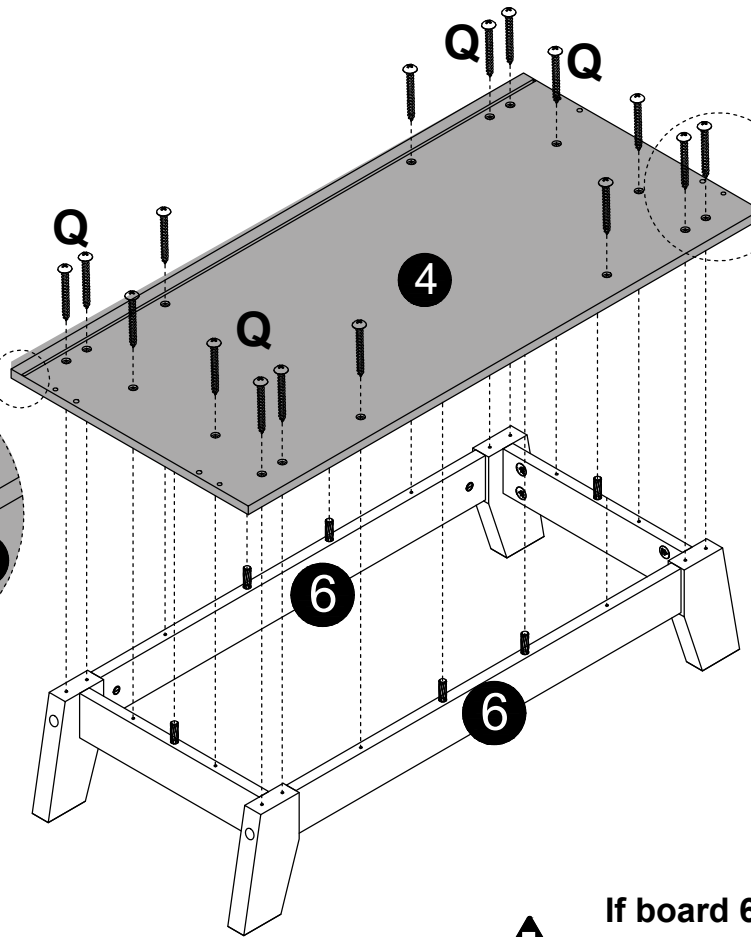

If board 6 does not have a 90 degree angle, please rotate board 6 90 degrees by hand.

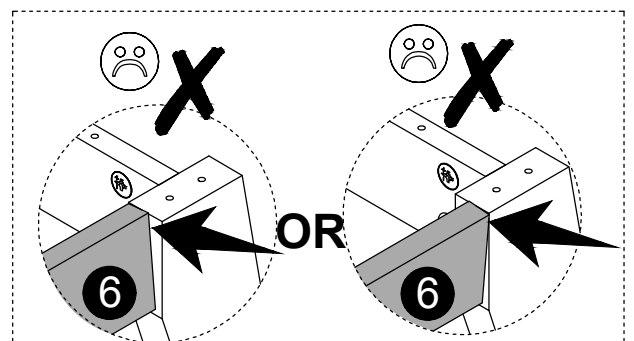
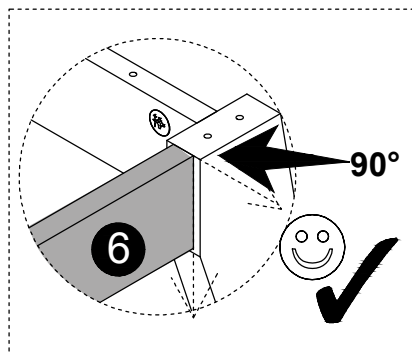

D x4

N x4

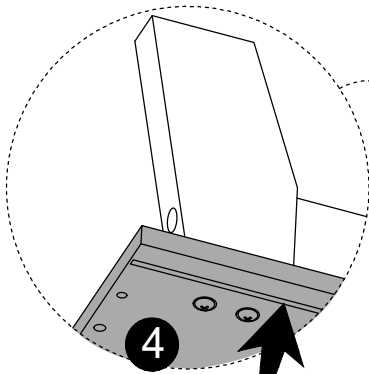
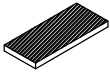
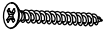

Notice

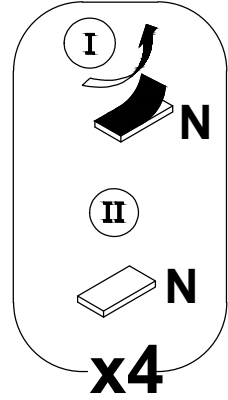
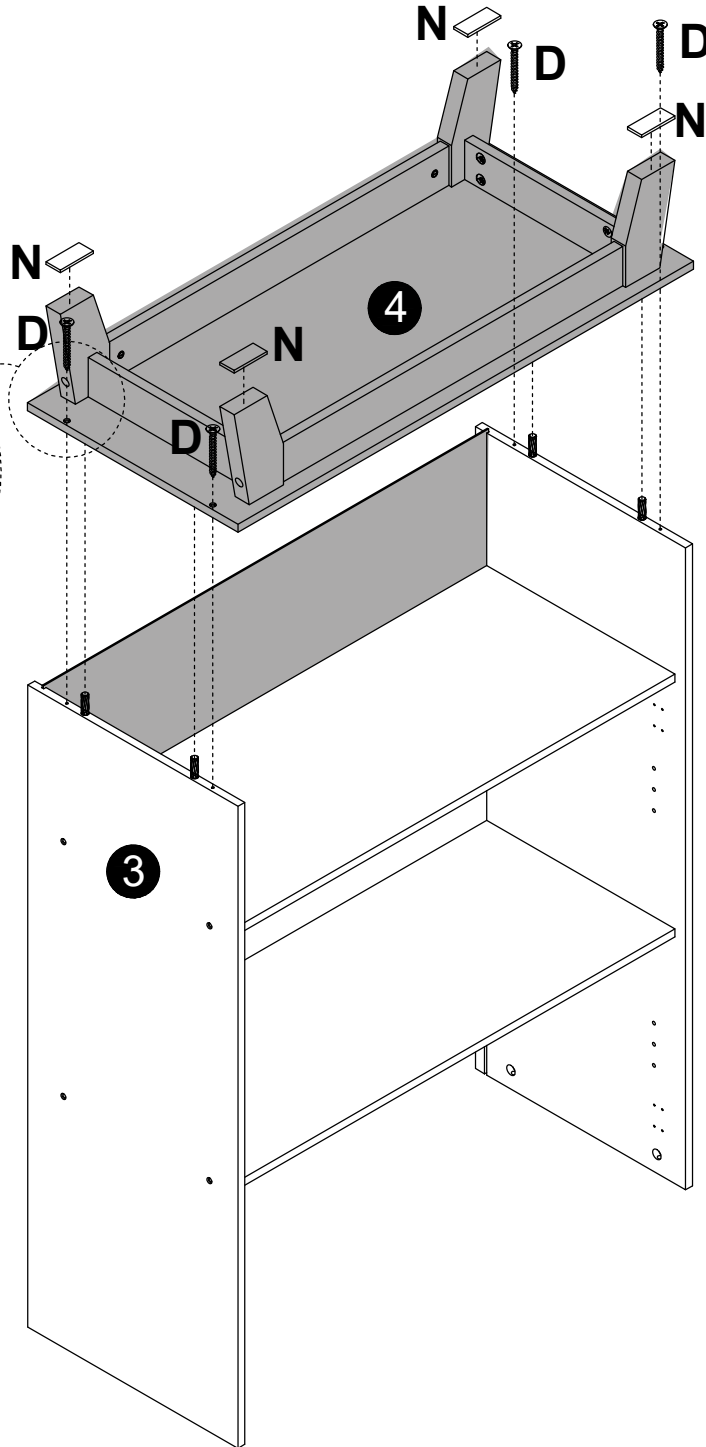

C x4



Note: At least two people are required for this step.

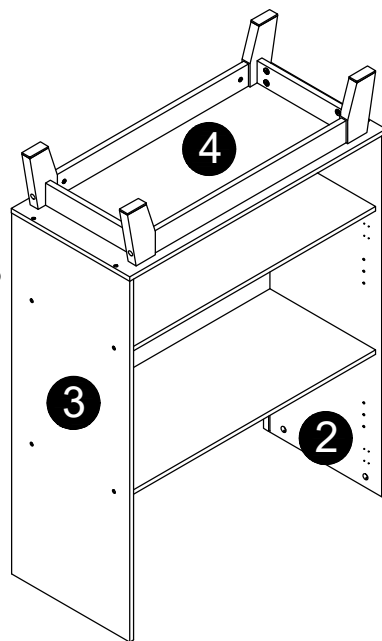
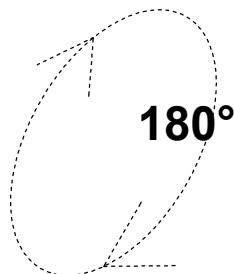
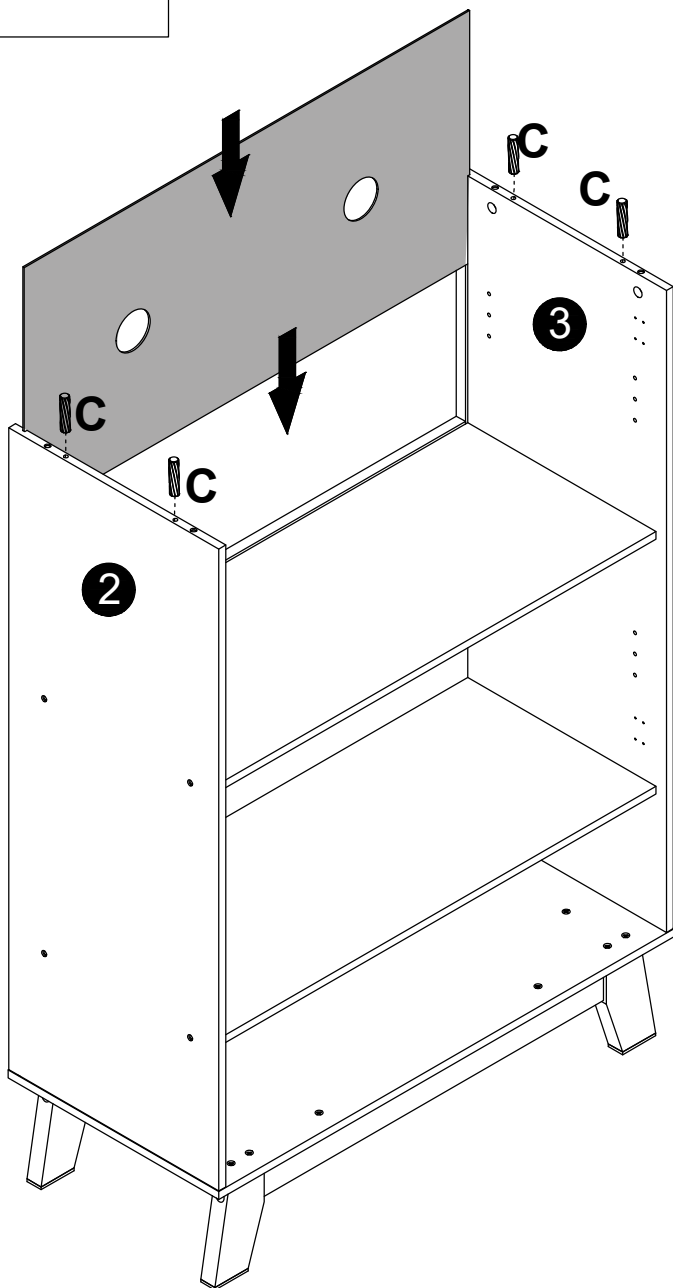

A x4

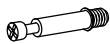

E x2



R x1

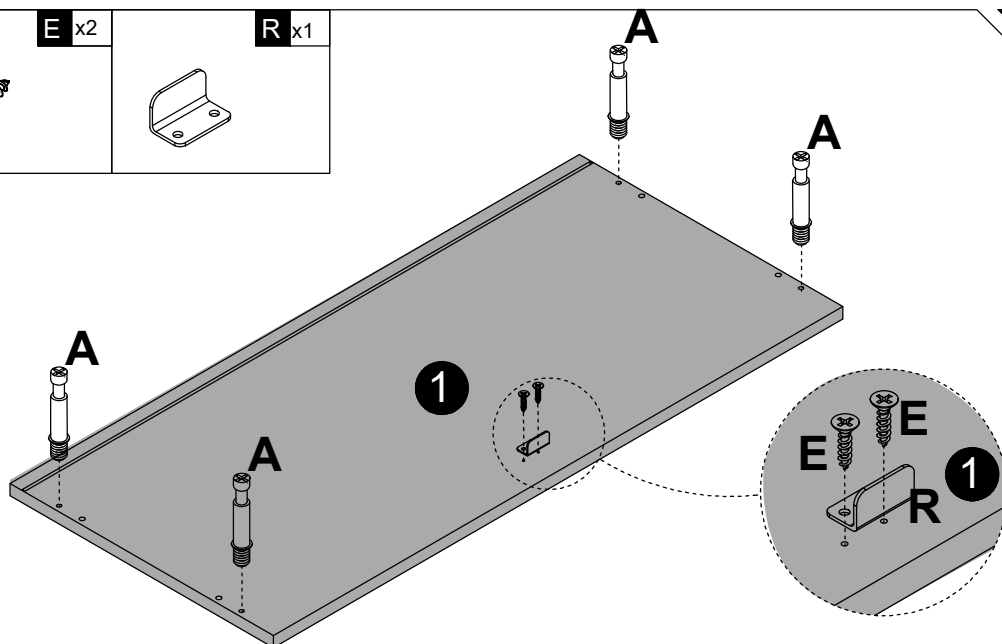

B x4

I x28
Ø20mm

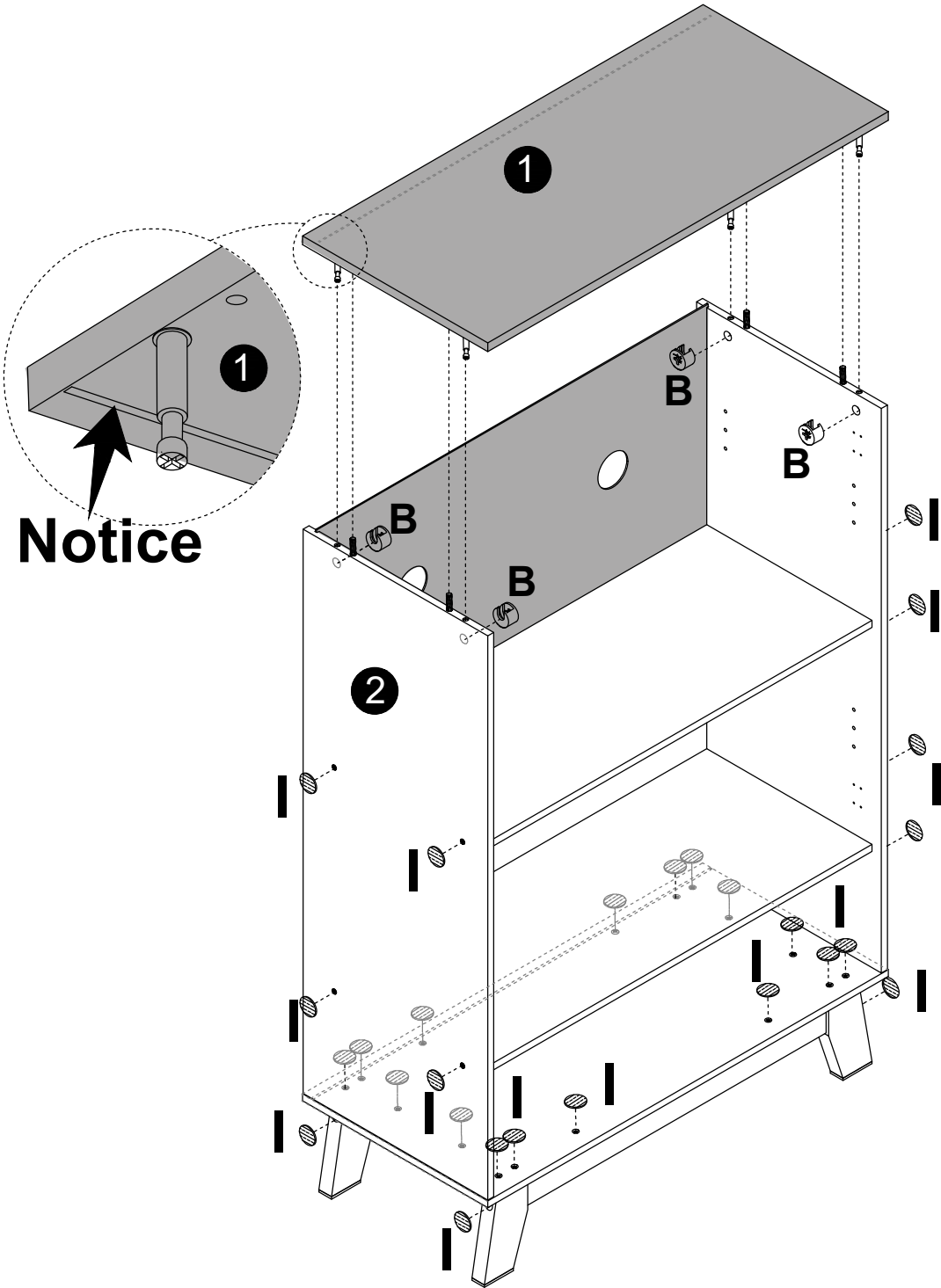

Notice

H x8

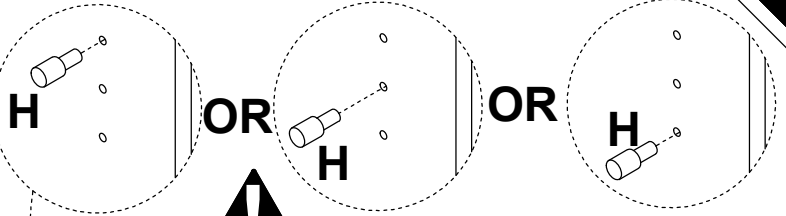
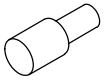

Please insert accessory H into the corresponding position according to your needs, with an adjustable distance of 32mm for each one.

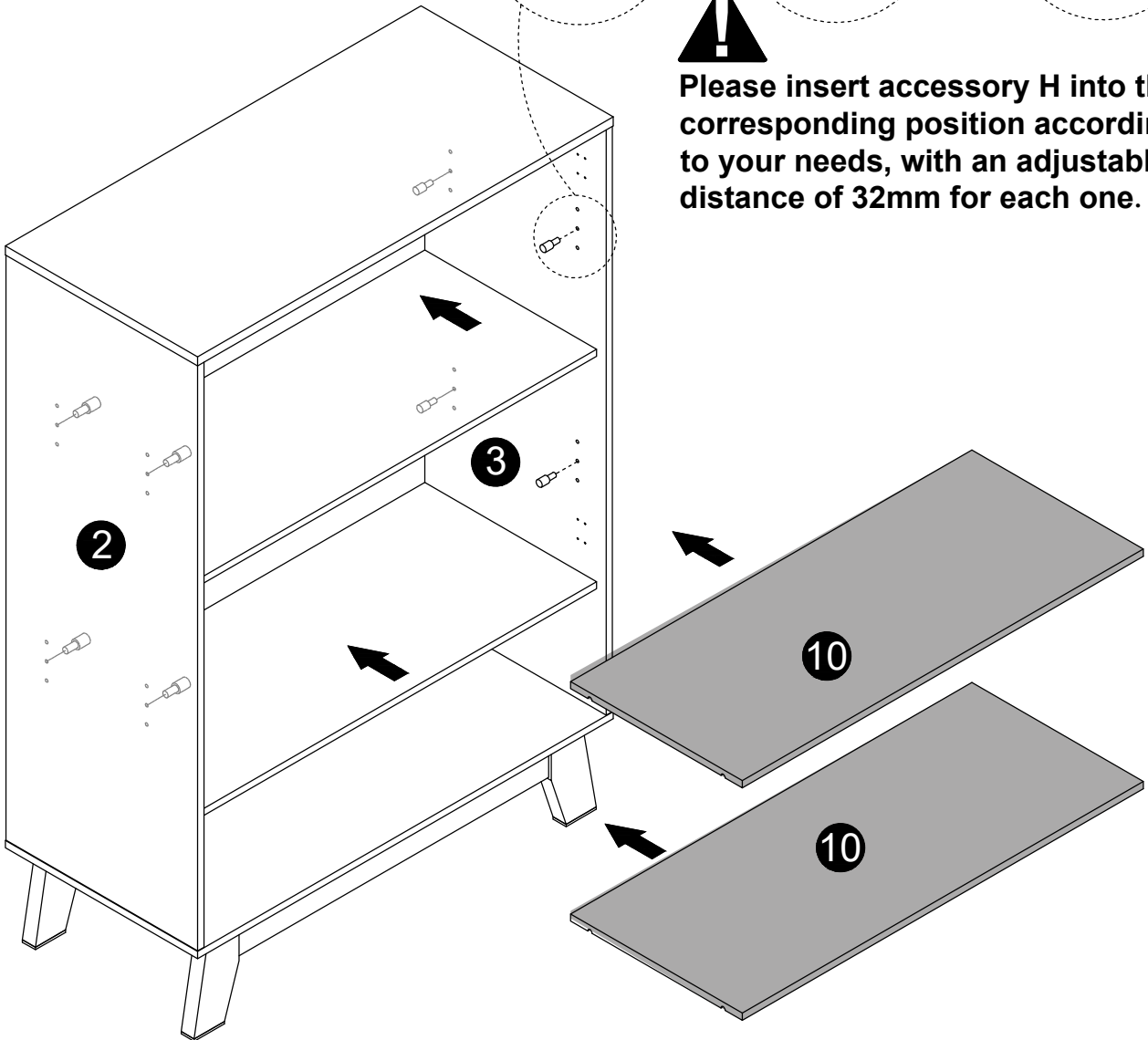

2

3

10

10

E x8

F x2

M x4

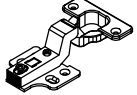
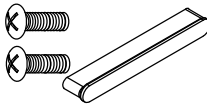

x2 15

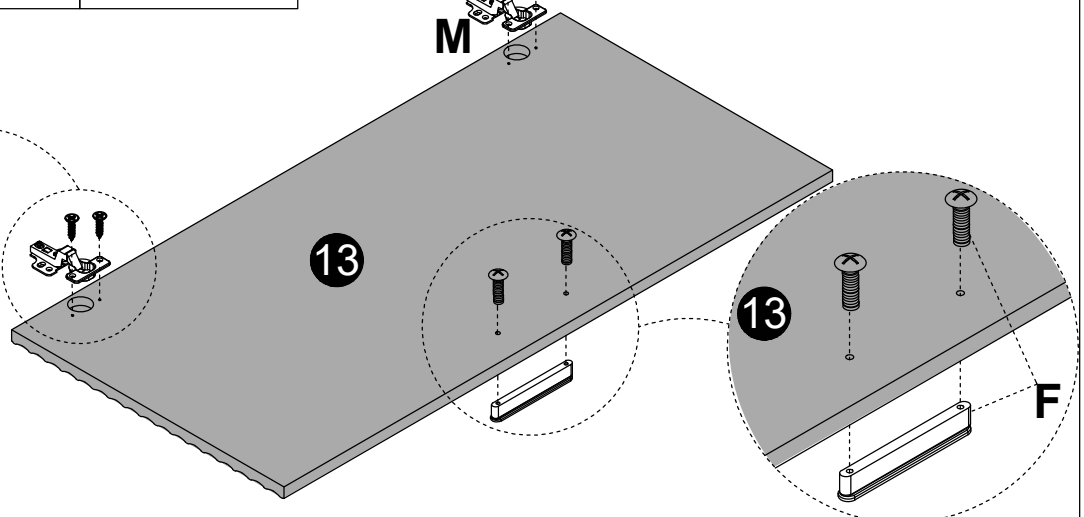
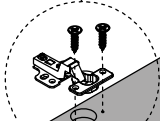
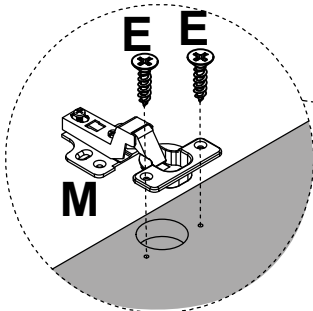

13

13

F

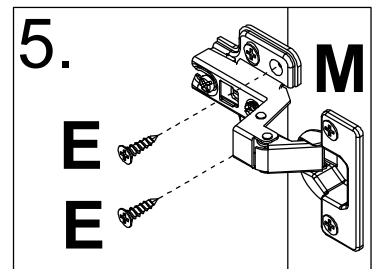
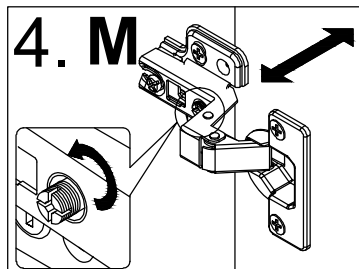
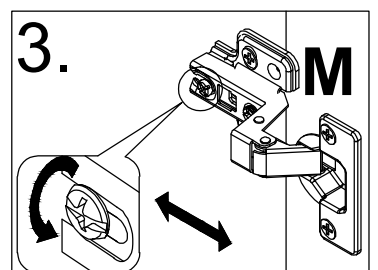
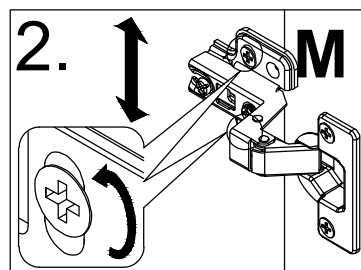
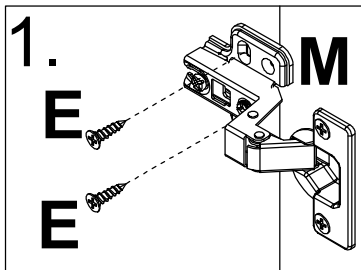
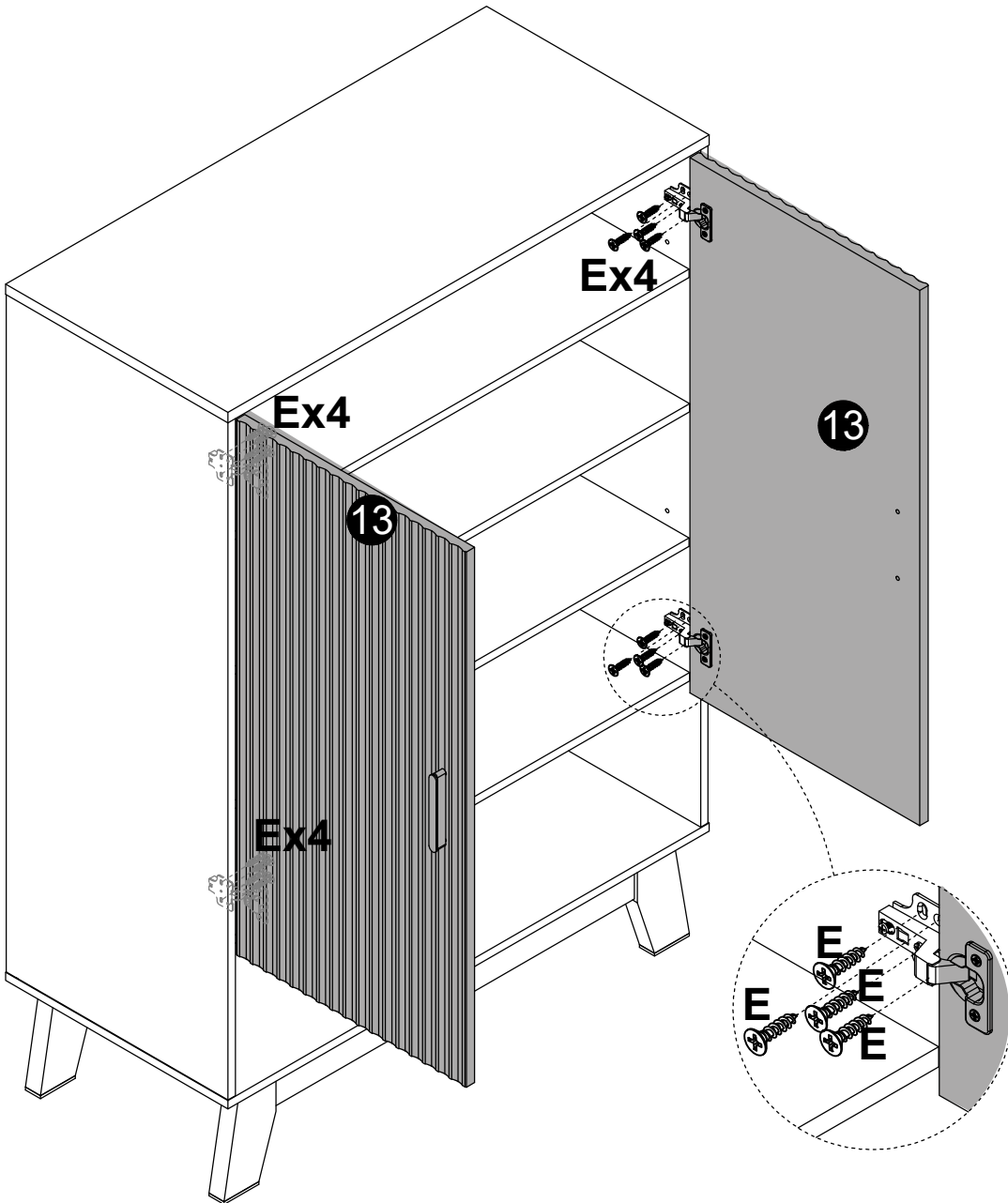

G x18

J x2

K x2

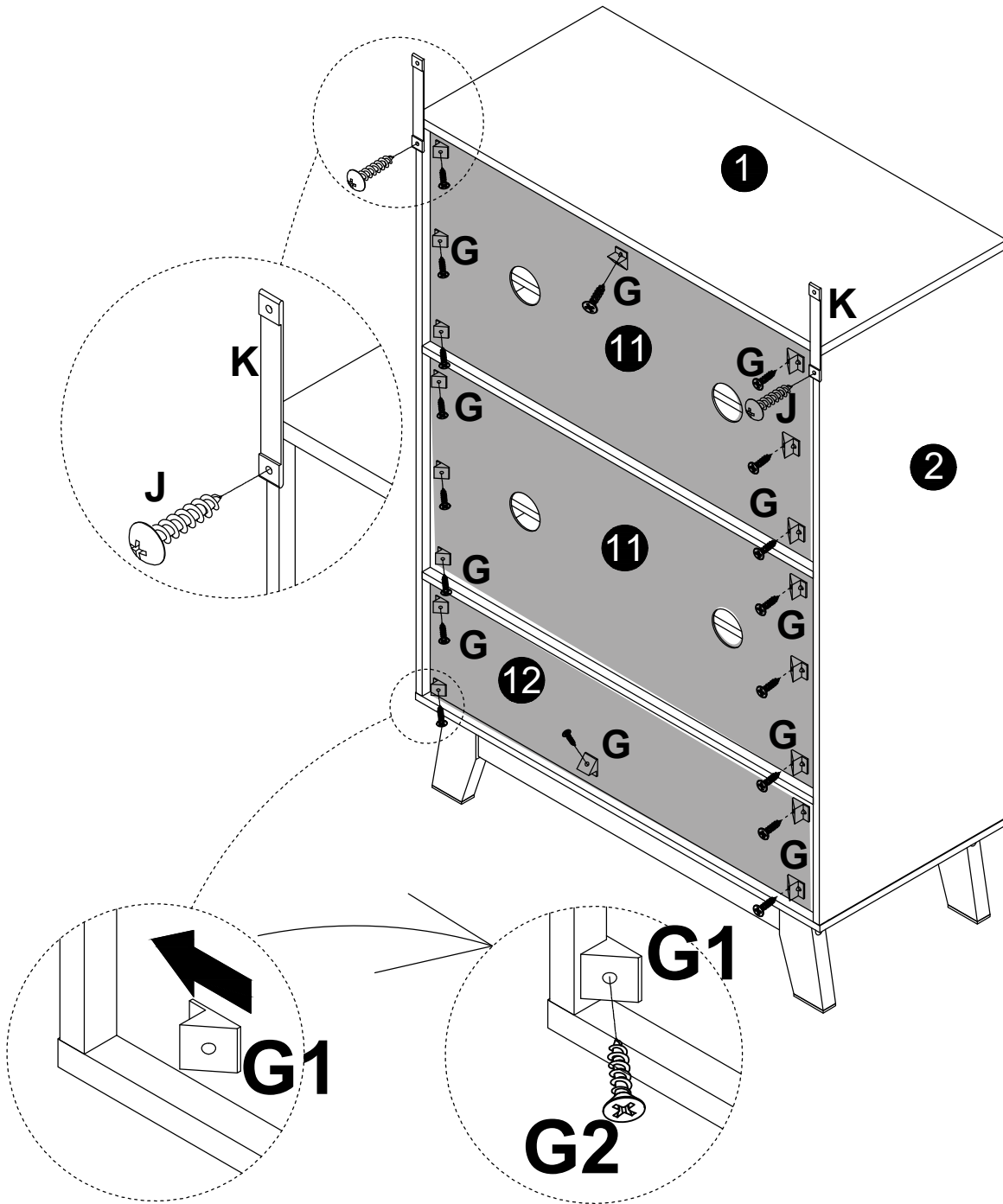

D x2

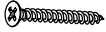

L x2

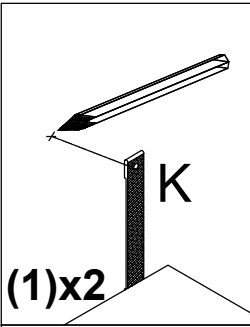

First, use a ruler to measure the approximate height of the product on the wall, and then mark it with a pen.

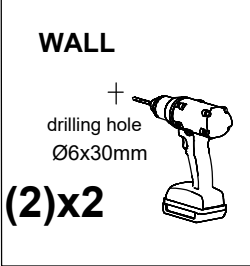

Then use a tape drill to make holes in the wall that are suitable for the product screws.

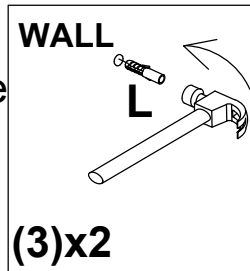

Then, put the expansion bolt into the hole

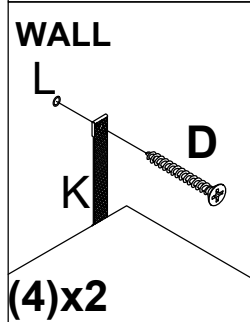

Finally, pass the matching screws through the "anti-rewind" and tighten them to fix them on the wall.

