

A

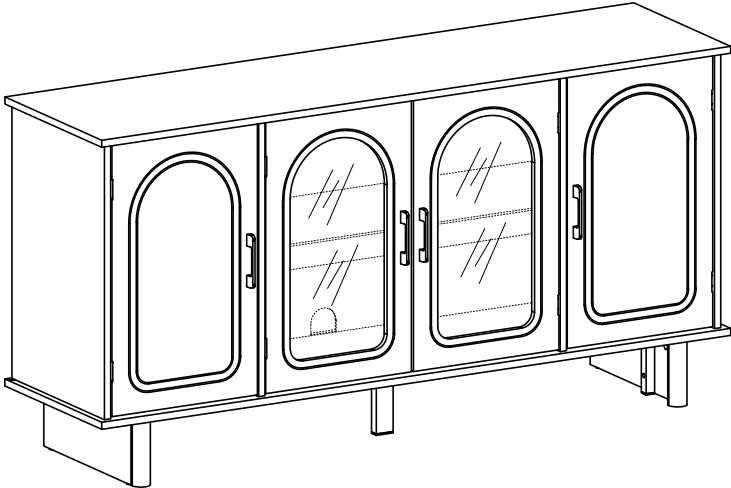

B

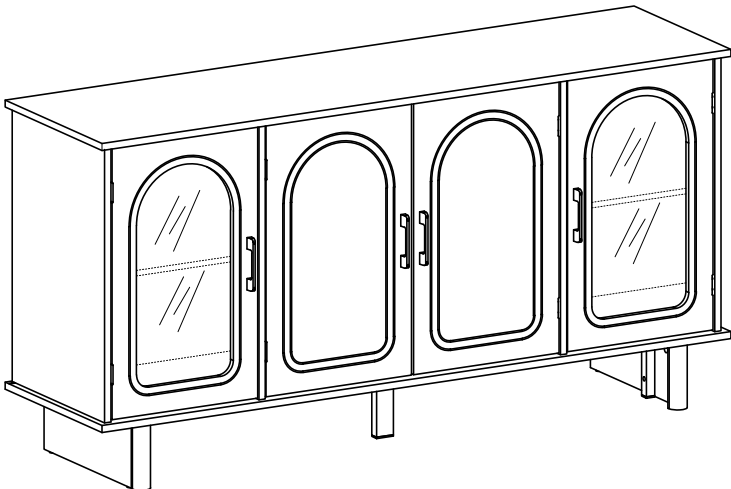

**ASSEMBLY  
INSTRUCTION**

Montageanleitung  
Instructions De Montage  
Istruzioni Per L'assemblaggio  
Instrucciones De Montaje  
어셈블리 설명  
組立説明書  
安装说明书



## HELPFUL HINTS

### BEFORE YOU START

- Inspect product packaging to ensure the appearance is good.
- Read the assembly instruction carefully and follow it step by step.
- To avoid any scratching, putting a soft blanket on the floor is suggested.
- Identify, sort and count all the parts with tags.
- Find out installation position according to the drawing and install it in correct steps.

### OTHER

- People needed for assembly: 1-2.
- Estimated assembly time: 1-1.5h.

### CAUTION

- Be cautious when using a power drill or power screwdriver.
- Please be aware to slow down and stop when screw is nearly tight.
- Do Not use any harsh chemicals or abrasive cleaners for this item.
- Push, pull or drag this item carefully.

## ASTUCES UTILES

### AVANT DE COMMENCER

- Inspectez l'emballage du produit pour vous assurer que l'apparence est bonne.
- Lisez attentivement les instructions de montage et suivez-les étape par étape.
- Pour éviter toute rayure, posez une couverture douce sur le sol est suggéré.
- Identifiez, triez et comptez toutes les pièces avec des étiquettes.
- Trouver la position d'installation selon le dessin et l'installer dans les étapes correctes.

### AUTRE

- Personnes nécessaires pour l'assemblage : 1-2.
- Temps de montage estimé : 1-1.5 h.

### AVERTIR

- Soyez prudent lorsque vous utilisez une perceuse électrique ou un tournevis électrique.
- Veuillez être conscient de ralentir et d'arrêter lorsque la vis est presque serrée.
- N'utilisez pas de produits chimiques corrosifs ou de nettoyants abrasifs pour cet article.
- Poussez, tirez ou tirez cet article avec précaution.

## CONSEJOS ÚTILES

### ANTES DE EMPEZAR

- Inspeccione el paquete del producto para asegurarse de que la apariencia es buena.
- Lea atentamente las instrucciones de montaje y sígalas paso a paso.
- Para evitar rayas, se sugiere poner una manta suave en el suelo.
- Identifique, clasifique y enumere todas las piezas con etiquetas.
- Averigüe la posición de instalación según el dibujo e instálela en los pasos correctos.

### OTROS

- Personas necesarias para el montaje: 1-2.
- Tiempo de montaje estimado: 1-1.5 h.

### PRECAUCIÓN

- Tenga cuidado al utilizar un taladro eléctrico o un destornillador eléctrico.
- Tenga en cuenta que debe hacerlo más despacio y detenerse cuando el tornillo esté casi apretado.
- No utilice productos químicos agresivos ni limpiadores abrasivos para este artículo.
- Empuje, tire o arrastre este elemento con cuidado.

## SUGGERIMENTI UTILI

### PRIMA DI INIZIARE

- Controllare la confezione del prodotto per assicurarsi che sia in buono stato.
- Leggere con attenzione le istruzioni per l'assemblaggio e seguirle passo dopo passo.
- Per evitare graffi al pavimento, suggeriamo di stendervi una coperta morbida.
- Identificare, suddividere e contare tutte le parti con etichetta.
- Trovare la posizione adatta per il montaggio in base al disegno e montare lo scaffale seguendo correttamente i vari passaggi.

### ALTRO

- Persone necessarie per l'assemblaggio: 1-2.
- Tempo di assemblaggio stimato: 1-1.5 ora.

### ATTENZIONE

- Prestare molta attenzione quando si utilizza un trapano elettrico o un cacciavite elettrico.
- Rallentare con accortezza e fermarsi quando una vite è già sufficientemente serrata.
- Non utilizzare prodotti chimici aggressivi o detergenti abrasivi su questo articolo.
- Spingere, tirare o trascinare questo articolo con cautela.

## NÜTZLICHE HINWEISE

### ⚠️ BEVOR SIE BEGINNEN

- Überprüfen Sie die Produktverpackung auf Schäden.
- Lesen Sie sich die Montageanleitung sorgfältig durch und befolgen Sie sie Schritt für Schritt.
- Um etwaiges Zerkratzen zu vermeiden, wird das Auslegen einer weichen Decke auf dem Boden empfohlen.
- Identifizieren, sortieren und zählen Sie alle Teile mit Tags nach.
- Identifizieren Sie die Montageposition gemäß der Zeichnung und bauen Sie das Regal den richtigen Schritten entsprechend auf.

**SONSTIGES**

- Für den Zusammenbau erforderliche Anzahl an Menschen: 1-2.
- Ungefährere Montagedauer: 1-1.5 h.

### ⚠️ VORSICHT

- Seien Sie bei der Verwendung einer Bohrmaschine oder eines Akkuschraubers vorsichtig.
- Bitte vergessen Sie nicht darauf, langsamer zu werden und zu stoppen, sobald die Schraube fast festgezogen ist.
- Verwenden Sie keinerlei aggressive Chemikalien oder scheuernden Reinigungsmittel für dieses Produkt.
- Schieben oder ziehen Sie dieses Produkt vorsichtig.

## 유용한 힌트

### ⚠️ 시작하기 전에

- 제품 포장 검사, 확보외관이 좋다.
- 어셈블리 지침 자세히 보기한 걸음 한 걸음 그것을 따르다
- 굽히지 않도록 바닥에 부드러운 담요를 놓는 것이 좋습니다
- 모든 부품을 라벨로 식별, 분류 및 계산합니다.
- 도면에 따라 설치 위치를 찾아 올바른 단계에 따라 설치합니다.

**기타**

- 조립에 필요한 인원: 1-2명.
- 예상 조립 시간: 1-1.5h.

### ⚠️ 안전에 주의하다:

- 전기 드릴이나 전기 드라이버를 사용할 때는 조심해야 한다
- 나사가 거의 조이면 속도를 줄이고 멈추십시오
- 자극성 화학물질이나 연마성 세정제는 이 품목에 사용하지 마십시오.
- 이 항목을 조심스럽게 밀거나 당기거나 드래그합니다

## 役に立つヒント

### ⚠️ 組立の場所を確保し、順番通りに組み立てる

- 組立場所 (充分広くて平たい場 所) を確保してください。
- 床や壁、商品を傷つけないように、商品の下に厚めの布や段ボールなどを敷いてください。
- 組立の順番を守らないと、組立できなくなったり、商品を傷つけたりします。

**その他**

- 組み立てに必要な人:1-2.
- 組立時間: 約1-1.5時間.

### ⚠️ 部品を確認する

- ネジ類などの部品番号、形状を説明書の部品一覧で確認してください。
- 部品をなくさないように纏めて置いてください。
- 部品を取り出すときに使う分だけ取り出してください。

## 温馨提示

### ⚠️ 安装前注意事项

- 检查产品包装，确保外观良好。
- 仔细阅读安装说明，按步骤操作。
- 为了避免刮伤，建议在地板上放一条柔软的毯子。
- 标识、分类和清点所有部件。
- 根据图形找到安装孔位，按正确步骤安装。

**其他:**

- 组装所需人员:1-2人.
- 预计组装时间: 1-1.5小时.

### ⚠️ 注意:

- 小心使用电钻或电动螺丝刀。
- 当螺丝快要拧紧时，请注意减速。
- 不要使用任何刺激性化学物质或擦洗剂。
- 当推、拉或拖动产品时，注意小心谨慎，防止损坏。

# DETAILS

DÉTAILS/POINTS DE MONTAGE  
NOTE PARTICOLARI  
DETALLES

디테일  
組み立てのポイント  
詳細情報

UNIT:INCH/CM/厘米

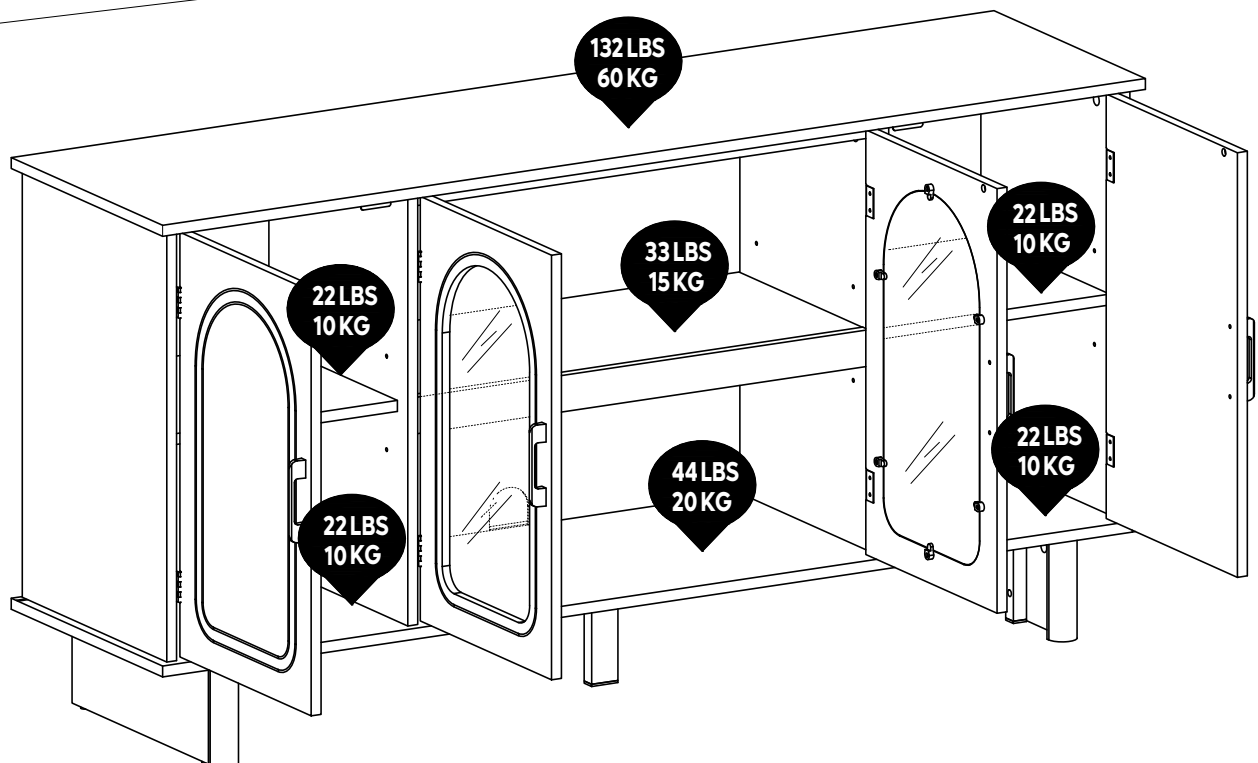
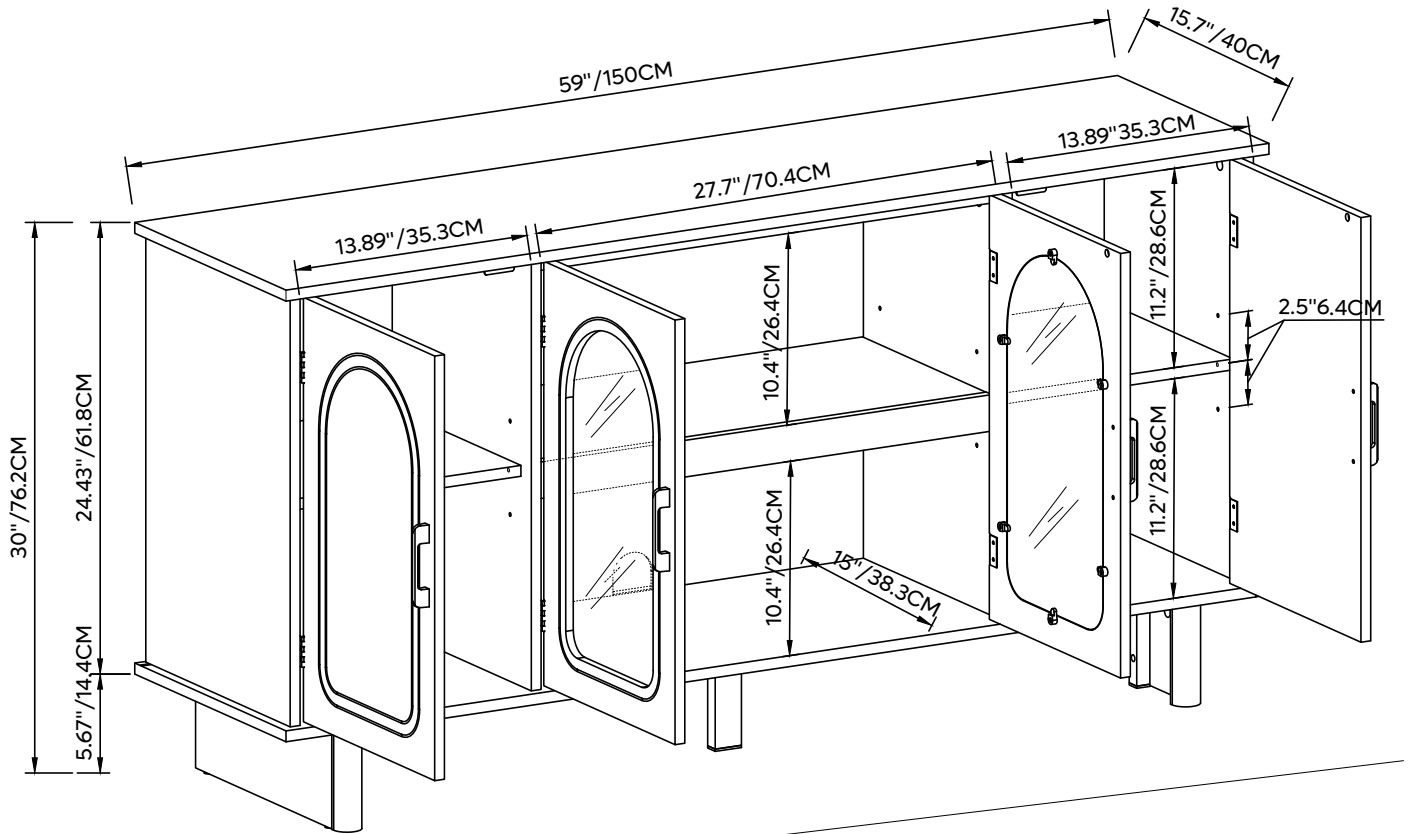

# DETAILS

DÉTAILS/POINTS DE MONTAGE  
NOTE PARTICOLARI  
DETALLES

디테일  
組み立てのポイント  
詳細情報

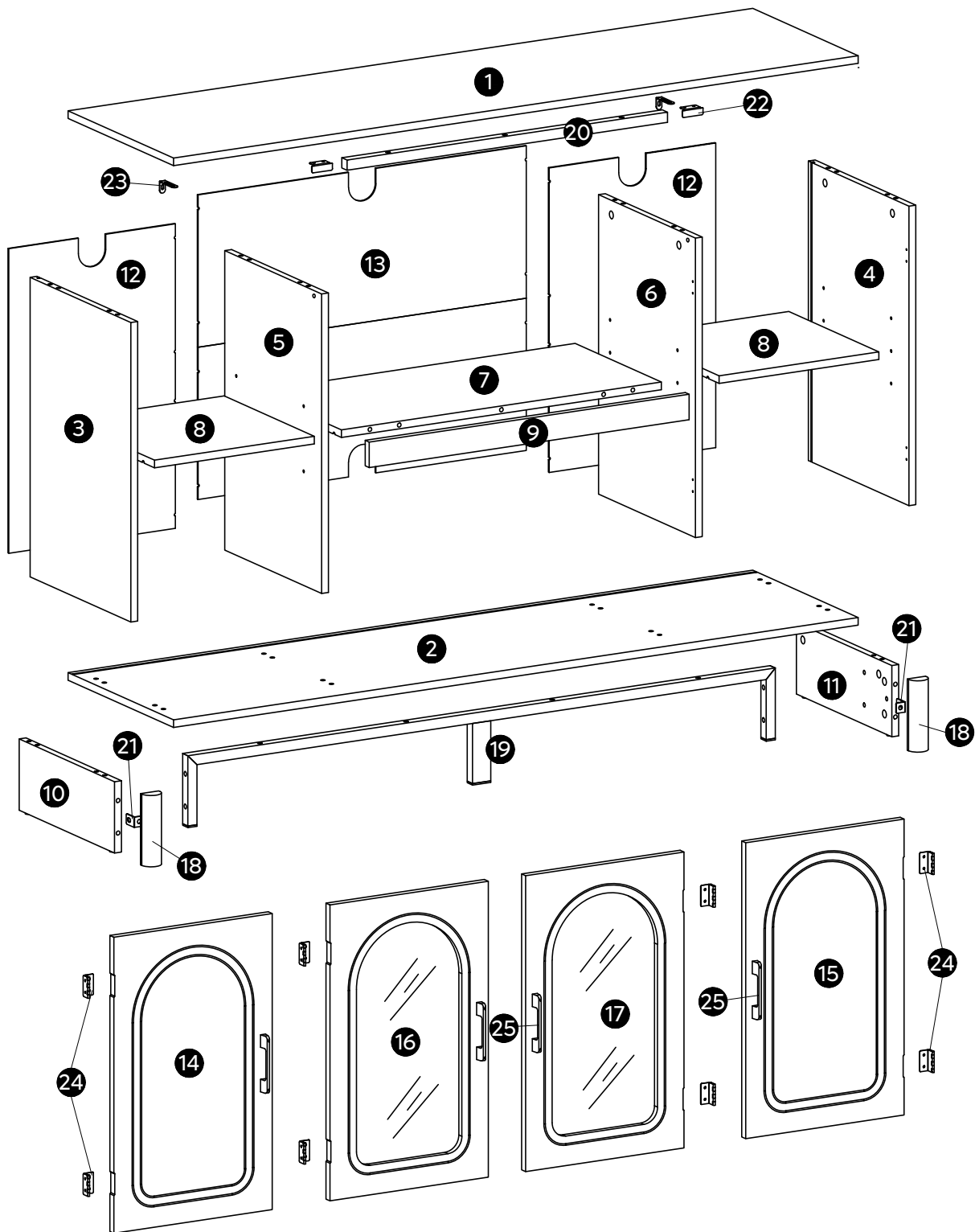

# PART LIST

STÜCKLISTE  
LISTE DES PIÈCES  
ELENCO DEI PEZZI

LISTA DE PIEZAS  
부품 목록  
部品の確認/部件清單

1

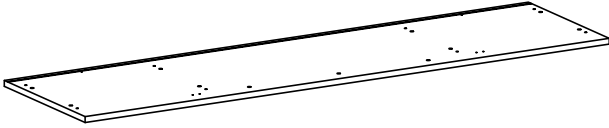

X1

2

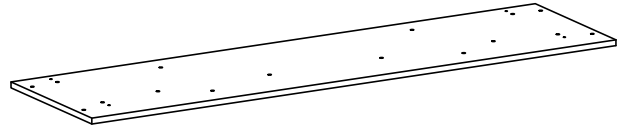

X1

3

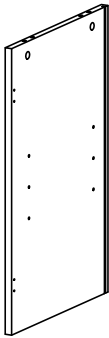

X1

4

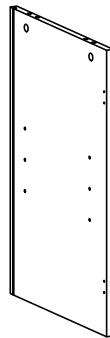

X1

5

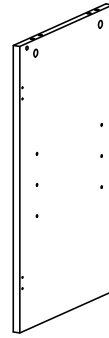

X1

6

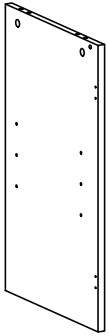

X1

7

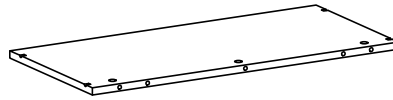

X1

8

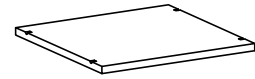

X2

9

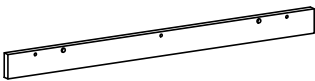

X1

10

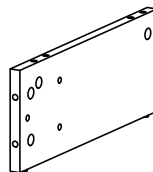

X1

11

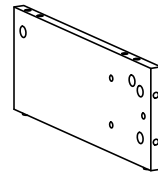

X1

12

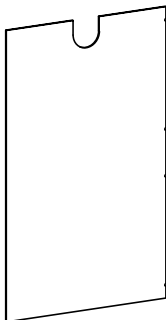

X2

13

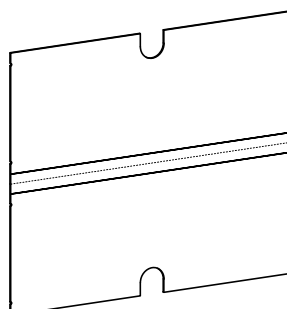

X1

14











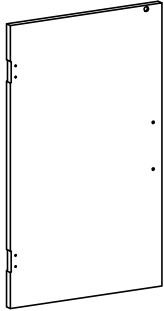

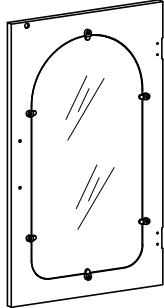
X1

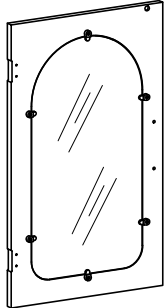
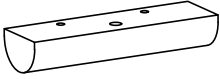
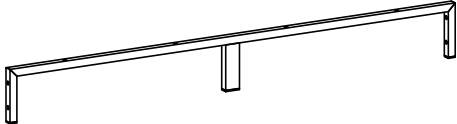
# PART LIST

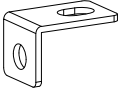
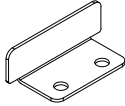
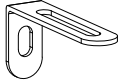
STÜCKLISTE  
LISTE DES PIÈCES  
ELENCO DEI PEZZI

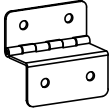





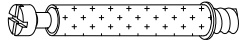

LISTA DE PIEZAS  
부품 목록  
部品の確認/部件清單

<p>15</p>  <p>X1</p>	<p>16</p>   <p>X1</p>	<p>17</p>   <p>X1</p>
<p>18</p>  <p>X2</p>	<p>19</p>  <p>X1</p>	<p>20</p>  <p>X1</p>
<p>21</p>  <p>X2</p>	<p>22</p>  <p>X2</p>	<p>23</p>  <p>X2</p>
<p>24</p>   <p>X8</p>	<p>25</p>  <p>X4</p>	

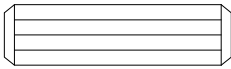
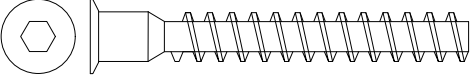
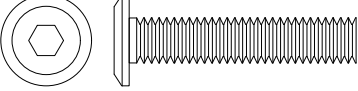
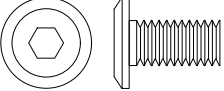
# ACCESSORY LIST

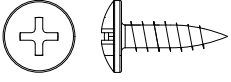
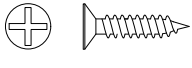
ZUBEHÖRLISTE  
LISTE DES ACCESSOIRES  
ELENCO DEGLI ACCESSORI

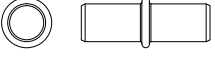
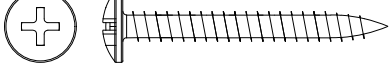
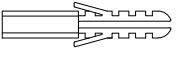
LISTA DE ACCESORIOS  
부품 목록  
付属品部品の確認/配件清單

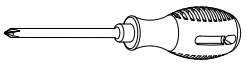
<b>A</b>	ST6x35mm	19+1	
<b>B</b>	Ø15mm	19+1	
<b>C</b>	Ø8x30mm	22+2	
<b>D</b>	ST7x50mm	8+1	
<b>E</b>	M6x30mm	13+1	
<b>F</b>	M6x12mm	4+1	
<b>G</b>	M4x19mm	8+1	
<b>H</b>	ST4x14mm	14+1	
<b>I</b>	ST3x14mm	36+2	
<b>J</b>		4+1	
<b>K</b>	Ø5x17mm	12+1	
<b>L</b>	ST4x35mm	2	
<b>M</b>		2	
	M4	1	
		1	

# Detailed Installation for Accessory A B

Installation détaillée pour l'accessoire A B  
 Detaillierte Installation des Zubehörs A B  
 Installazione dettagliata per l'accessorio A B  
 Instalación detallada del accesorio A B

액세서리 A 및 액세서리 B의 상세 설치

カムロック取り付け方

配件A、B详细安装

1

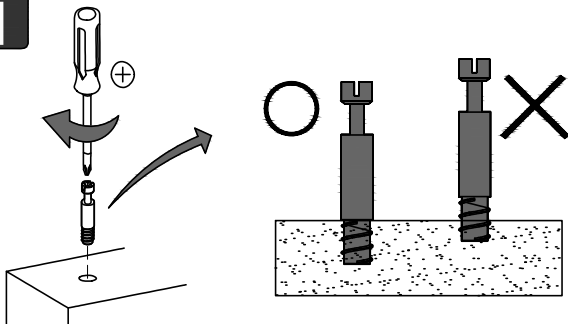

Screw cam dowel on the panel.  
 Vissez la goupille de came au panneau.  
 Nockendübel auf die Platte schrauben.  
 Avvitare il tassello a camme sul pannello.  
 tornillo de pasador de leva en el panel.  
 캠 핀을 패널에 조입니다.  
 カムロックネジを部品に取り付ける。  
 螺杆用十字螺丝刀装入对应的预留孔内

Place another panel via the dowel.  
 Placez un autre panneau par le goujon.  
 Setzen Sie eine weitere Platte über den Dübel ein.  
 Posizionare un altro pannello tramite il tassello.  
 Coloque otro panel a través del pasador.  
 핀을 통해 다른 패널을 배치합니다.  
 カムロックネジをカムロック穴に差し込む。  
 螺杆插入对应孔位，将两块板材对接起来。

2

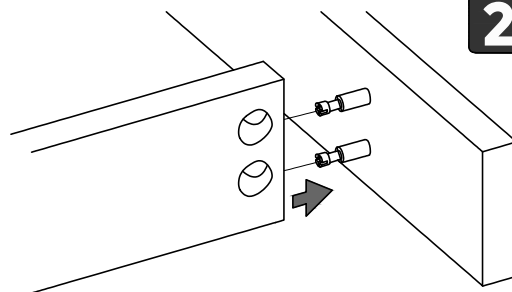

3

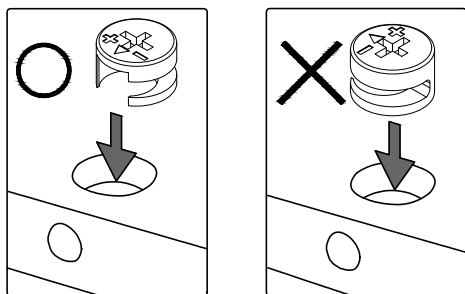

Pay attention to the direction of cam lock when putting it into hole.  
 Faites attention à la direction du verrou à came en entrant dans le trou.  
 Achten Sie auf die Richtung des Nockenschlosses, wenn Sie es in das Loch stecken.  
 Fare attenzione alla direzione della serratura a camme quando lo si inserisce nel foro.  
 Preste atención a la dirección de la leva de fijación al insertarla en el orificio.  
 캠 자물쇠를 구멍에 넣을 때 캠 자물쇠의 방향에 주의하십시오.  
 カムロックネジの方向にカムロックの穴の穴の向きを合わせ取り付け。  
 装入锁扣圆盘，注意锁扣圆盘的方向；

Tighten up cam lock clockwise until it stops.  
 Serrez le verrou à came dans le sens des aiguilles d'une montre jusqu'à ce qu'il s'arrête.  
 Ziehen Sie die Nockenverriegelung im Uhrzeigersinn bis zum Anschlag an.  
 Stringere la serratura a camme in senso orario fino all'arresto.  
 Apriete la leva de fijación en sentido horario hasta el tope.  
 타이밍에 맞춰 캠 자물쇠가 멈출 때까지 조입니다.  
 カムロックをドライバーで締め固定する。  
 顺时针旋转锁扣圆盘并锁紧。

4

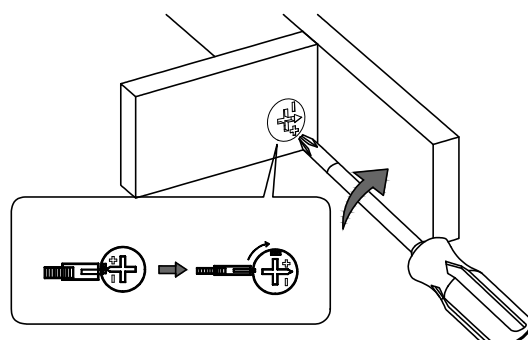

1

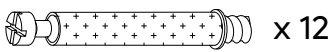
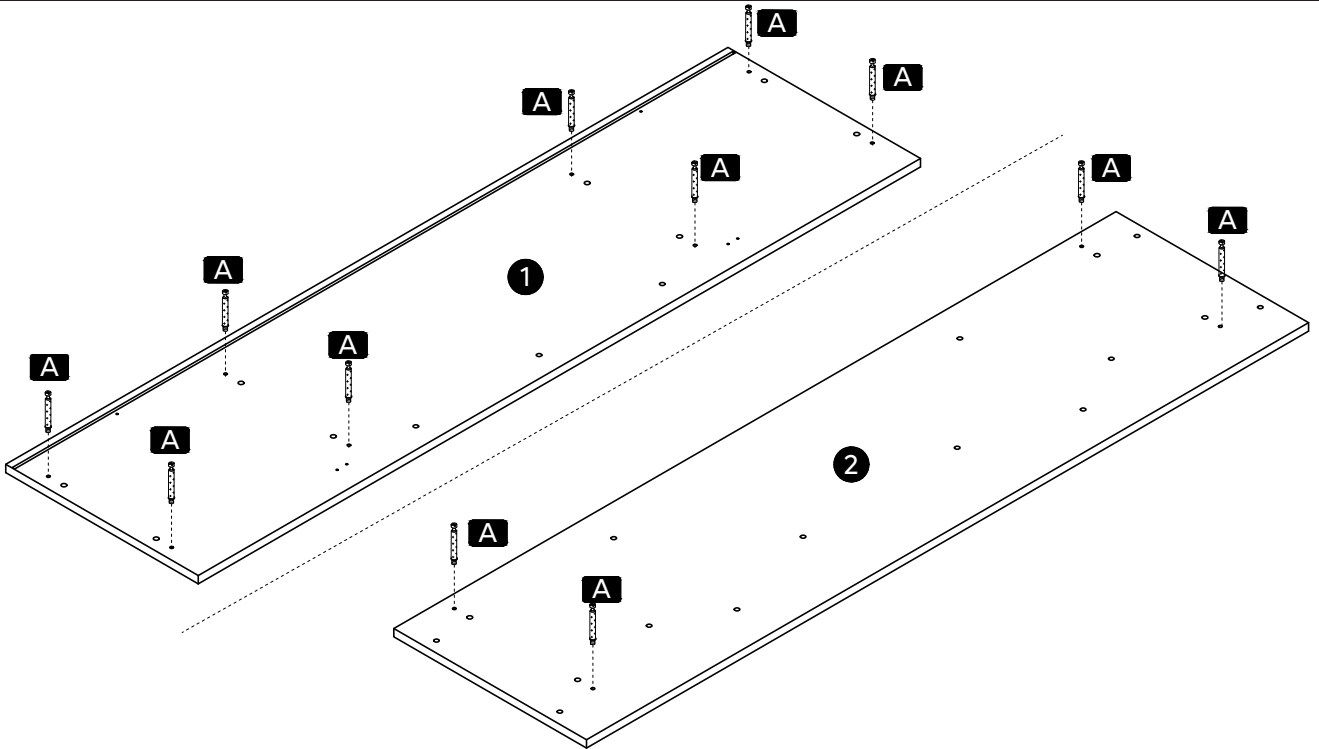

x 12

A ST6x35mm

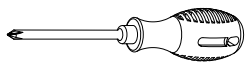

2

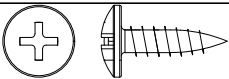
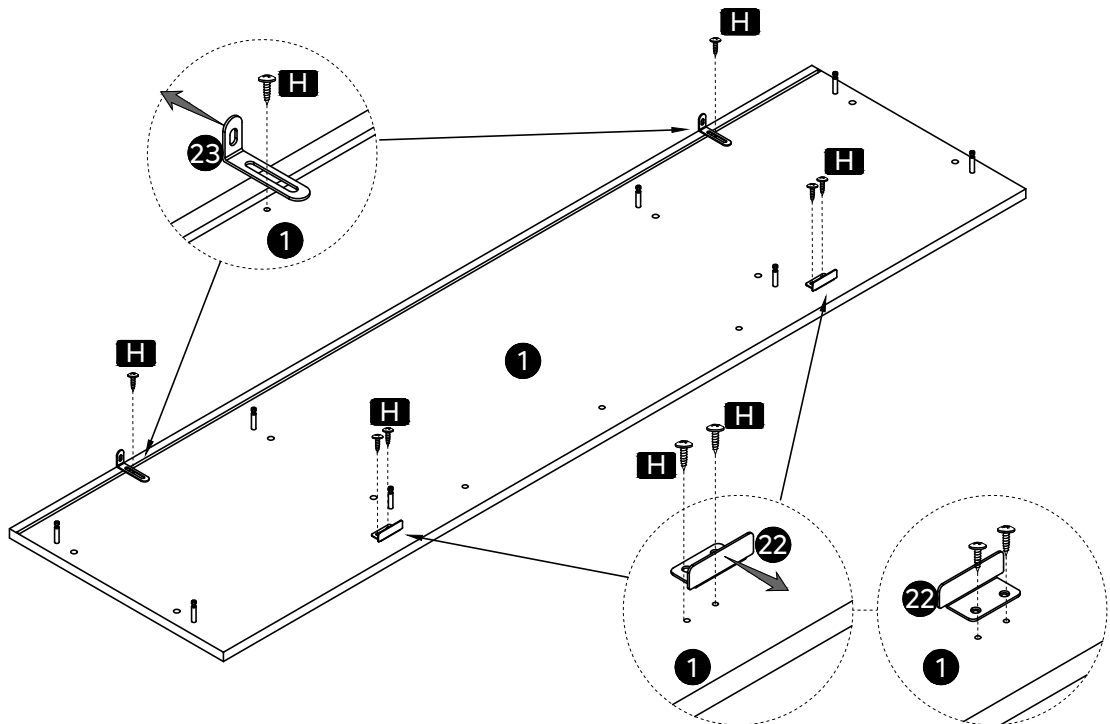

x 6

H ST4x14mm

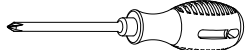

### 3

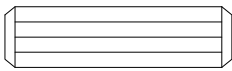
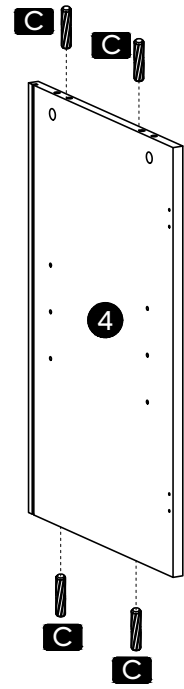
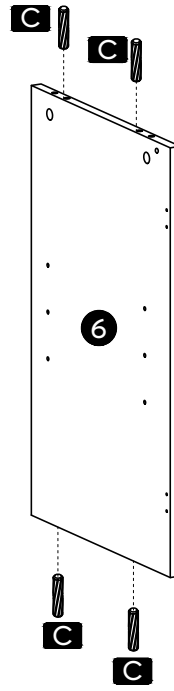
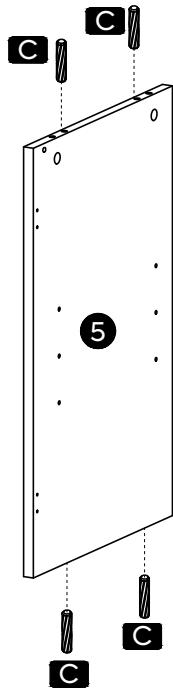
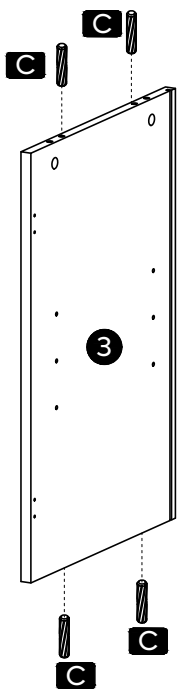

x16

**C** Ø8x30mm

### 4

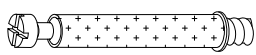
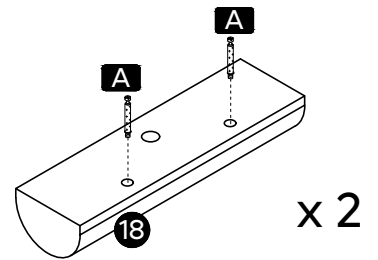
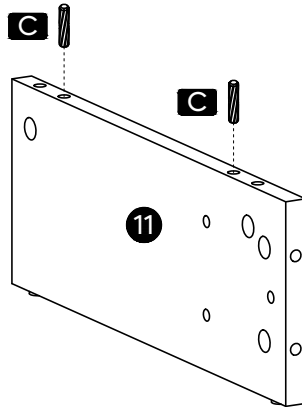
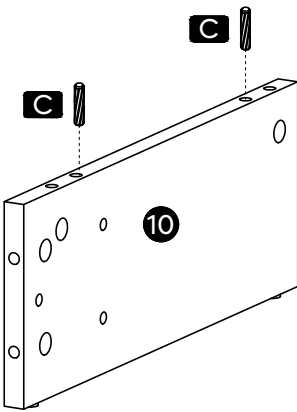

x 4

**A** ST6x35mm

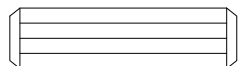

x4

**C** Ø8x30mm

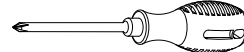

5

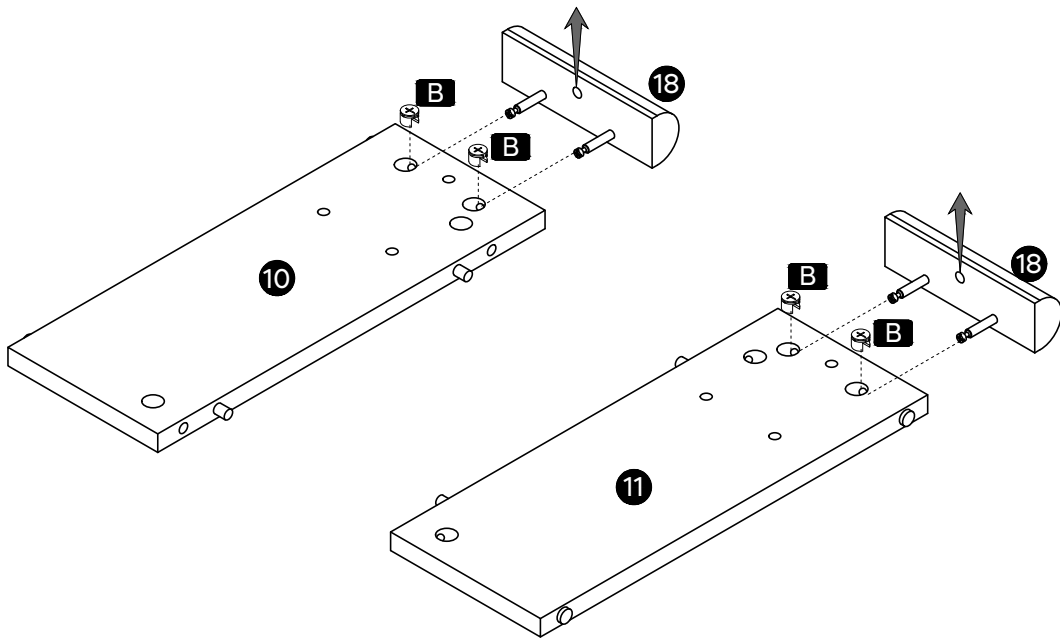

x 4

**B** Ø15mm

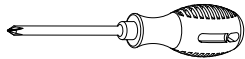

6

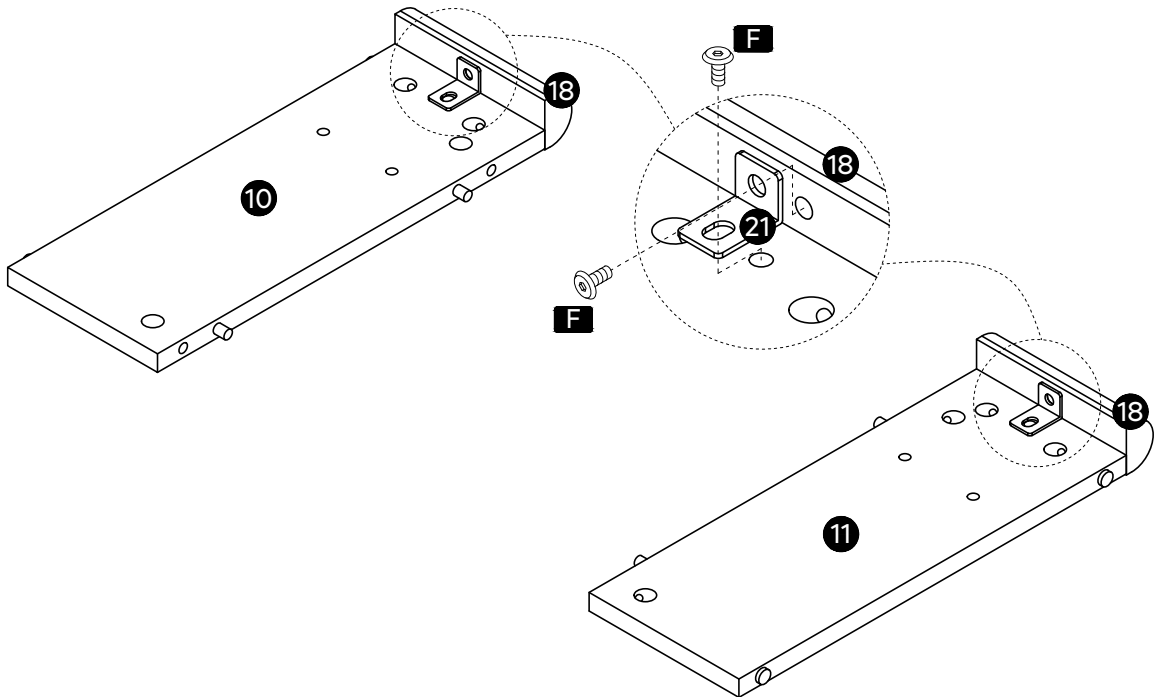

x 4

**F** M6x12mm



- ※ The side with groove inside faces toward the top.
- ※ Le côté avec la rainure intérieure est orienté vers le haut.
- ※ Die Seite mit innerer Nut ist nach oben gerichtet.
- ※ Il lato con scanalatura interna si rivolge verso la parte superiore.
- ※ El lado con ranura dentro se dirige hacia la parte superior.
- ※ 안쪽 구멍이 있는 측면은 상단으로 향합니다.
- ※ 内側の内側の内内内側は上側に向かっています。
- ※ 帶有卡槽的一端朝向顶部。

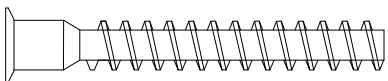
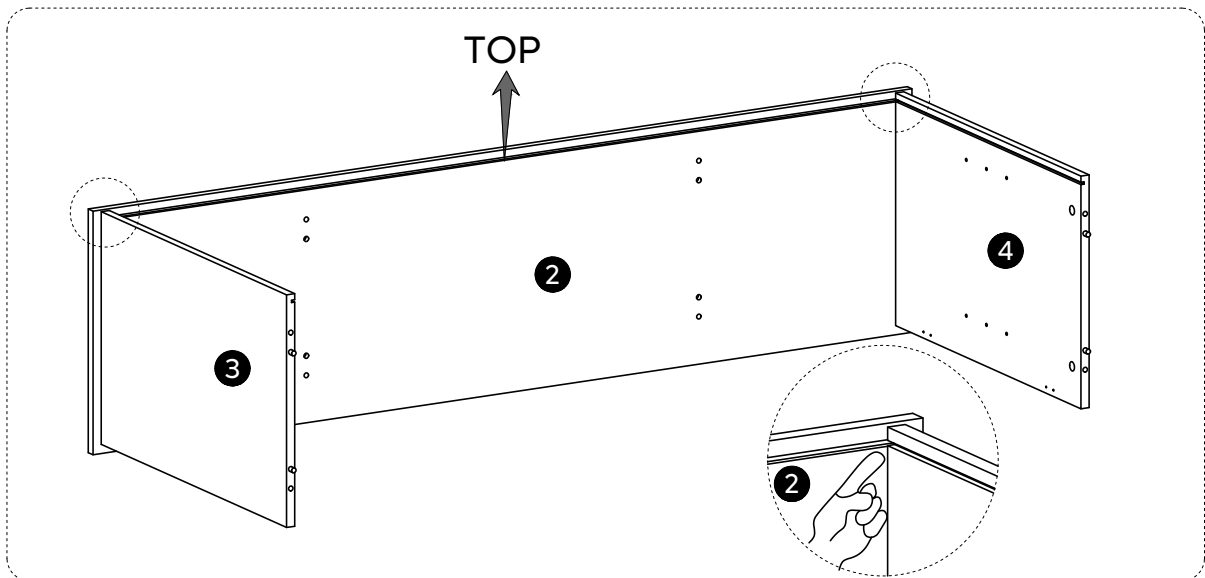
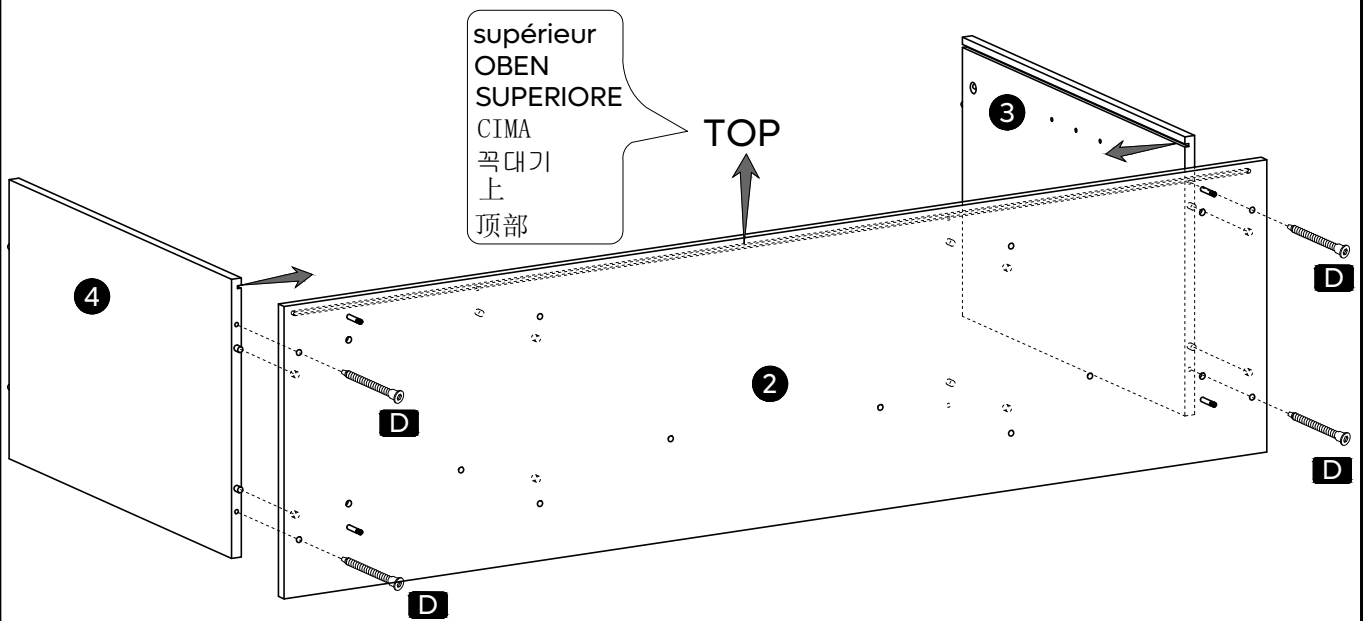

x 4

D

ST7x50mm



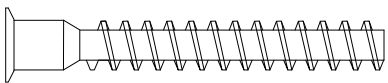
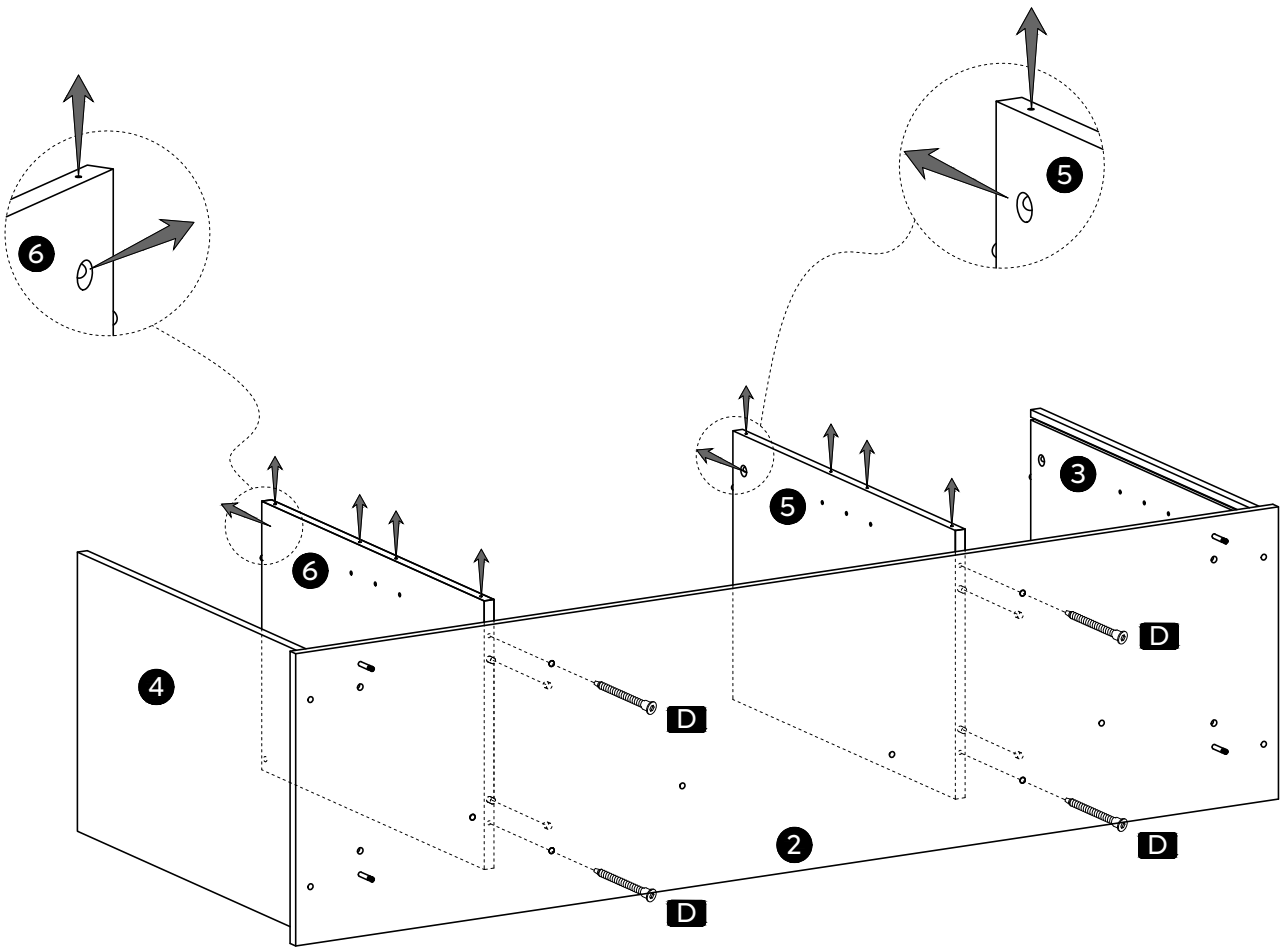

x 4



ST7x50mm



9

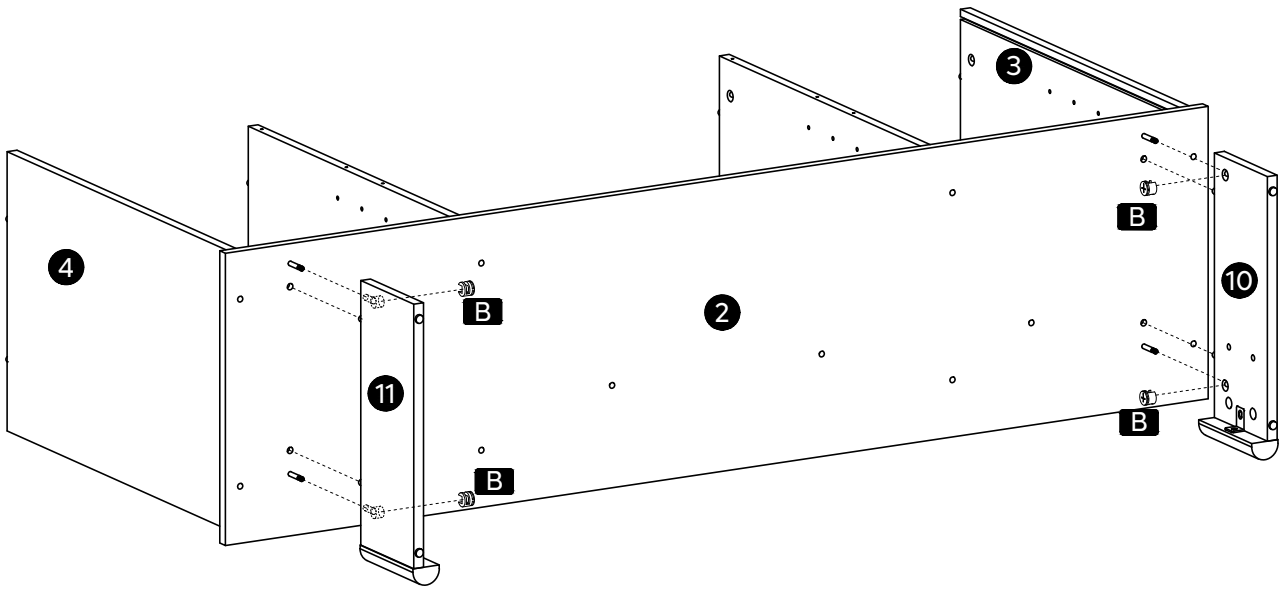

x 4

**B** Ø15mm

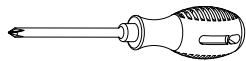

10

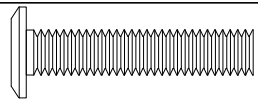
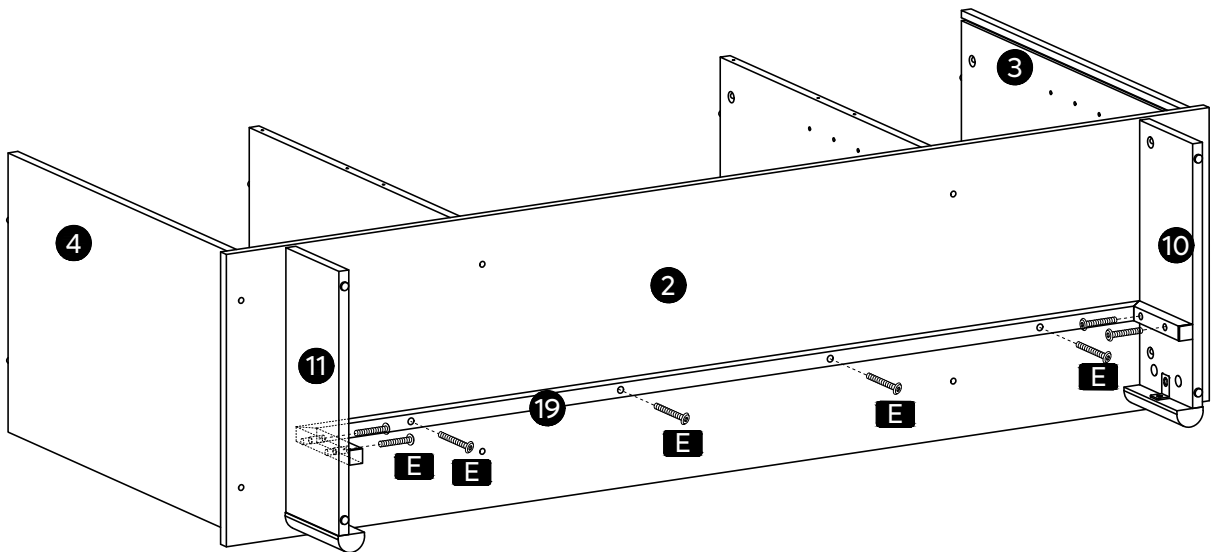

x 8

**E** M6x30mm



11

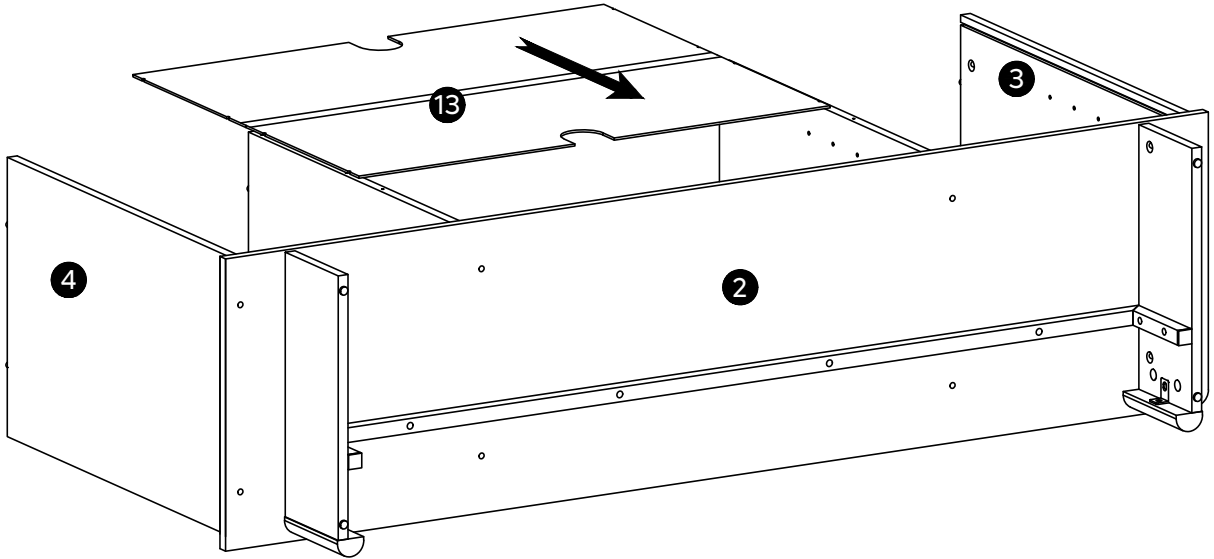

12

- ※ Two persons are needed.
- ※ Deux personnes sont nécessaires.
- ※ Zwei Personen sind erforderlich.
- ※ Sono necessarie due persone.
- ※ Se necesitan dos personas.
- ※ 두 사람이 필요합니다.
- ※ 必ず2人で作業してください。
- ※ 需要另1个人协助。

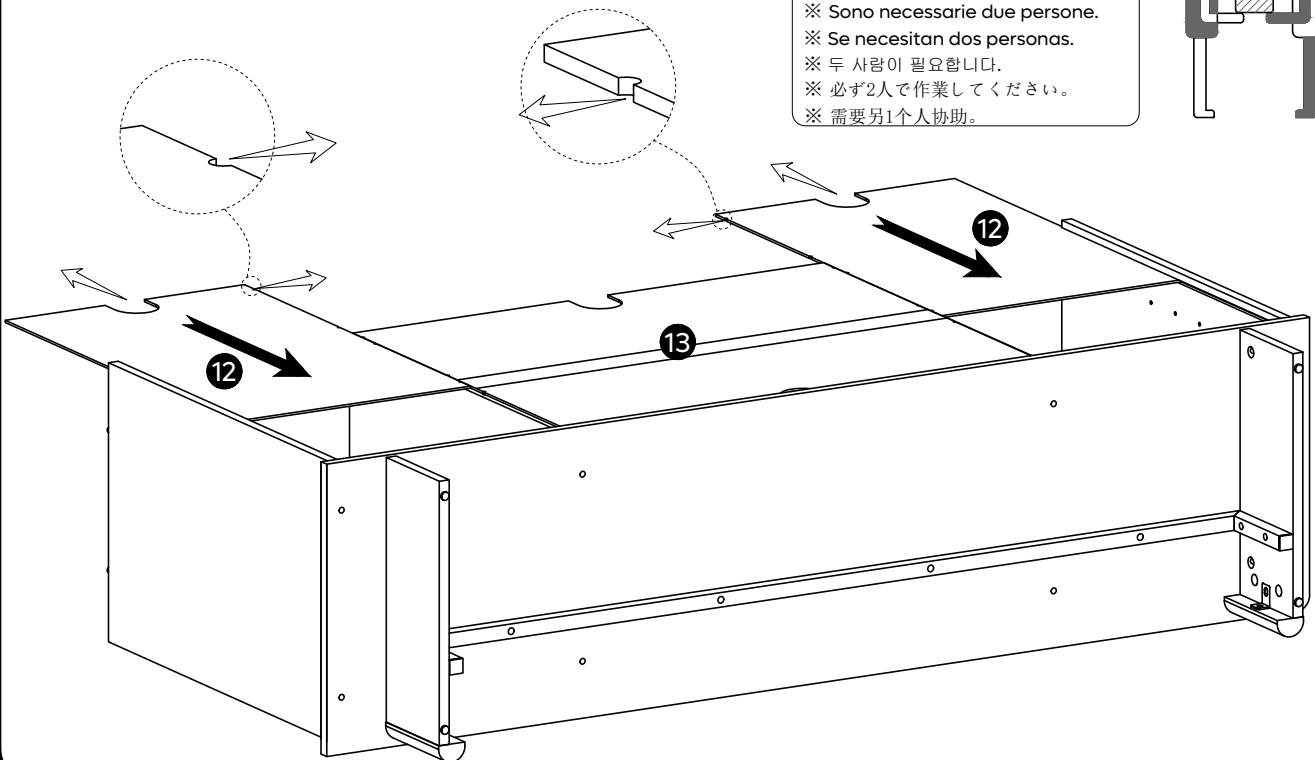
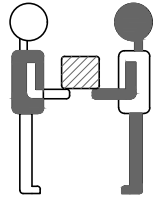

# 13

- ※ Two persons are needed.
- ※ Deux personnes sont nécessaires.
- ※ Zwei Personen sind erforderlich.
- ※ Sono necessarie due persone.
- ※ Se necesitan dos personas.
- ※ 두 사람이 필요합니다.
- ※ 必ず2人で作業してください。
- ※ 需要另1个人协助。

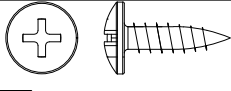
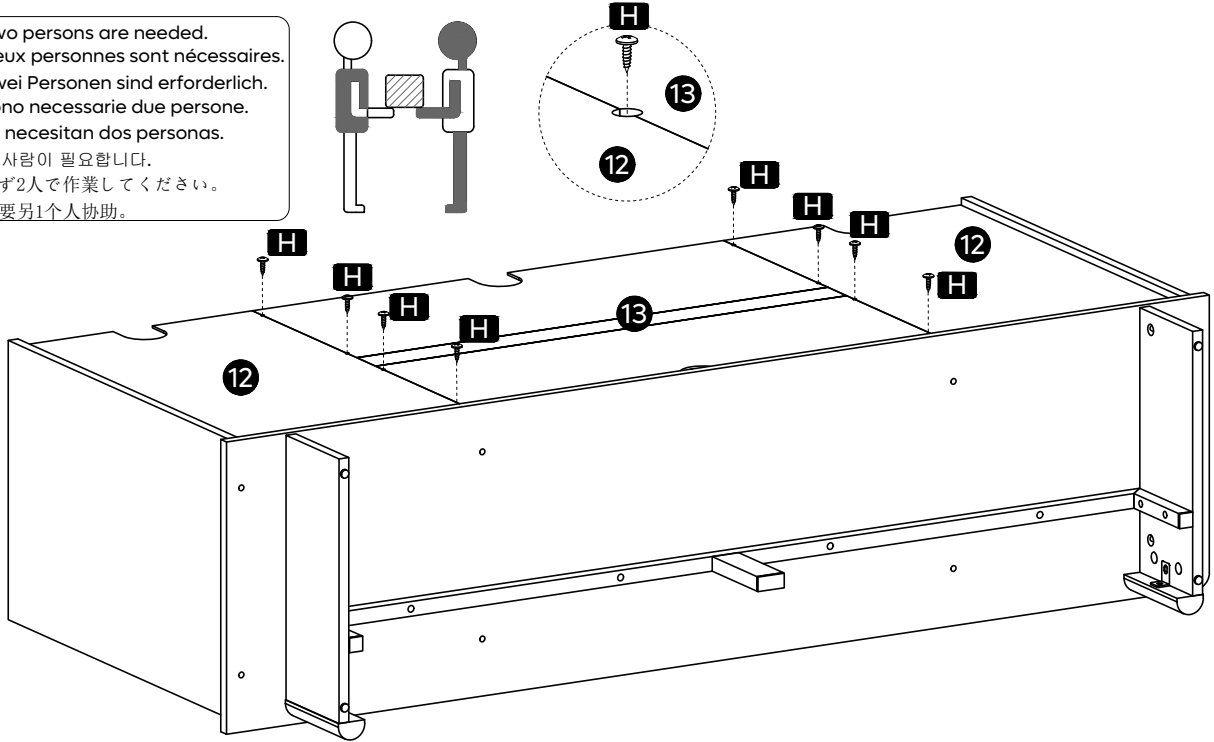

x 8

**H** ST4x14mm

# 14

- ※ Turn over.
- ※ Retournement.
- ※ Umdrehen.
- ※ Capovolgere.
- ※ Girar.
- ※ 뒤집어.
- ※ 反転する。
- ※ 翻转过来。

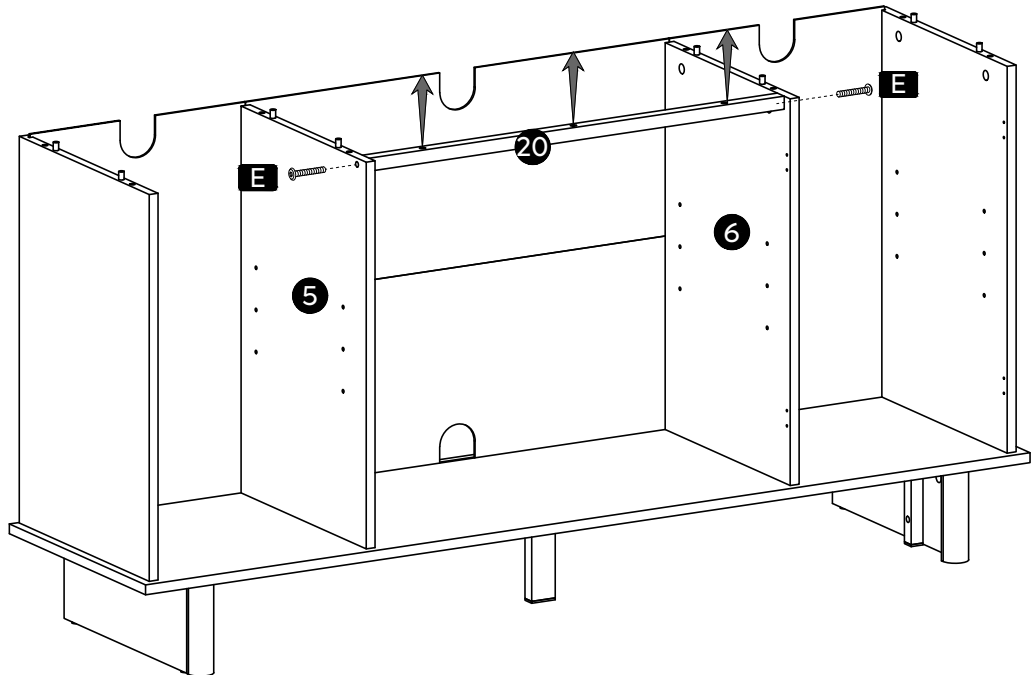
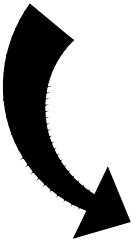

x2

**E** M6x30mm

- ※ Two persons are needed.
- ※ Deux personnes sont nécessaires.
- ※ Zwei Personen sind erforderlich.
- ※ Sono necessarie due persone.
- ※ Se necesitan dos personas.
- ※ 두 사람이 필요합니다.
- ※ 必ず2人で作業してください。
- ※ 需要另1个人协助。

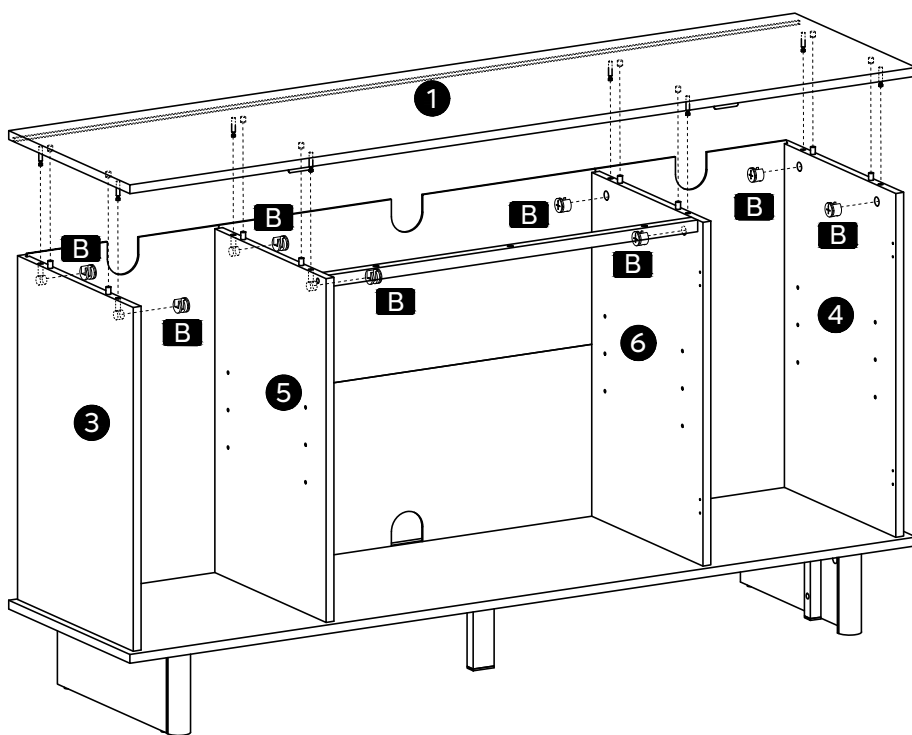
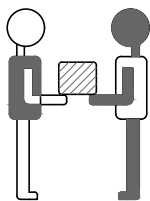

x 8

**B** Ø15mm

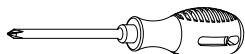

16

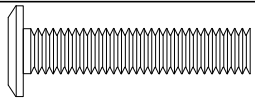
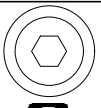
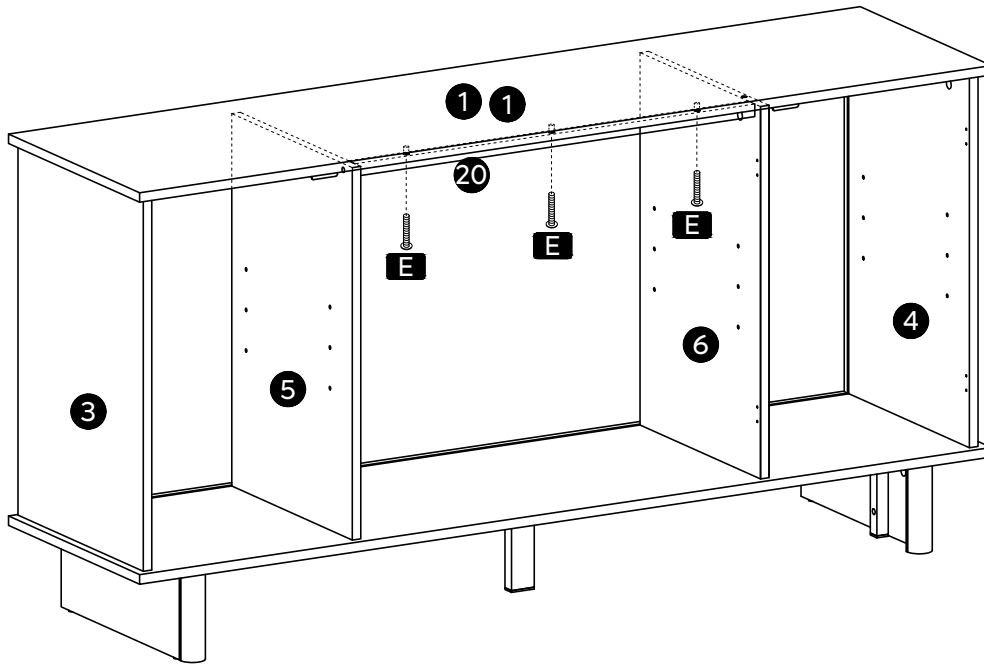

x3



**E** M6x30mm

17

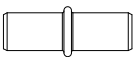
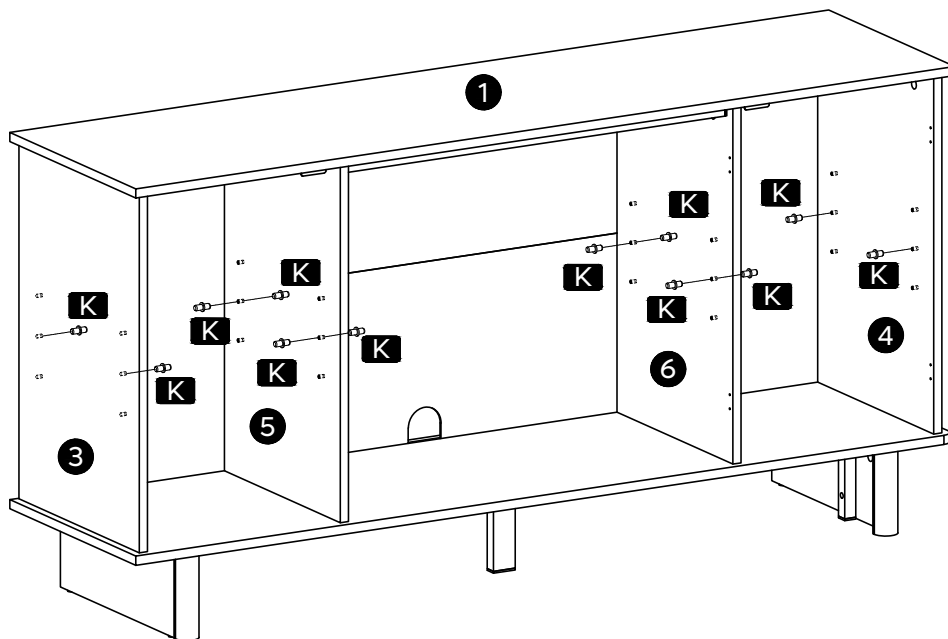

x12

**K** Ø5x17mm

# 18

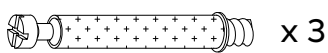
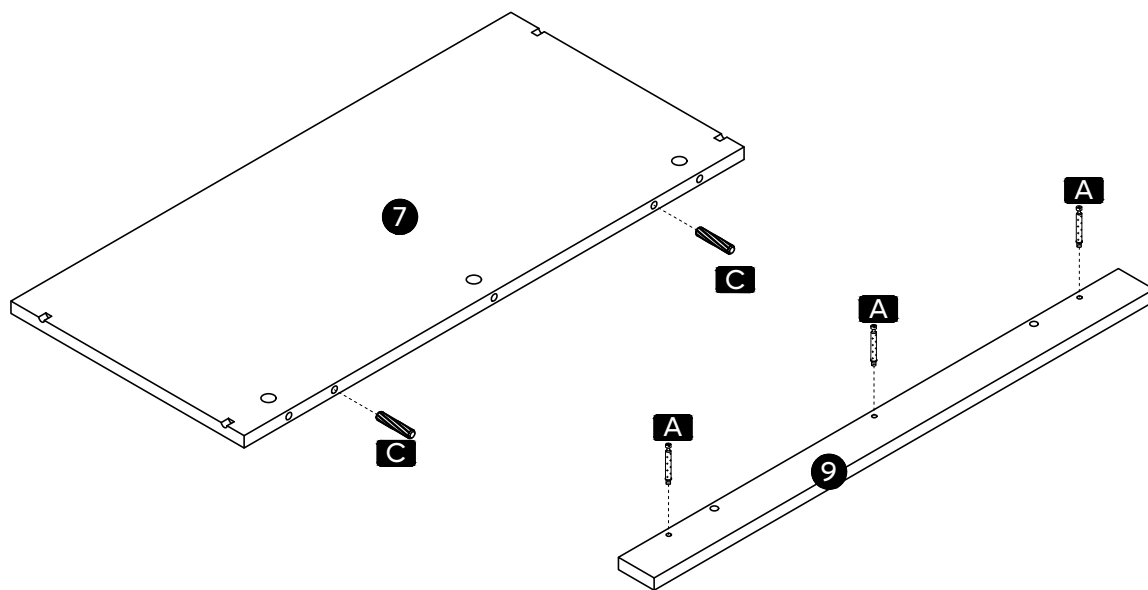

x 3

**A** ST6x35mm

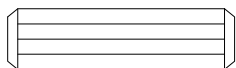

x 2

**C** Ø8x30mm

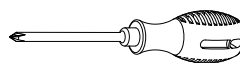

# 19

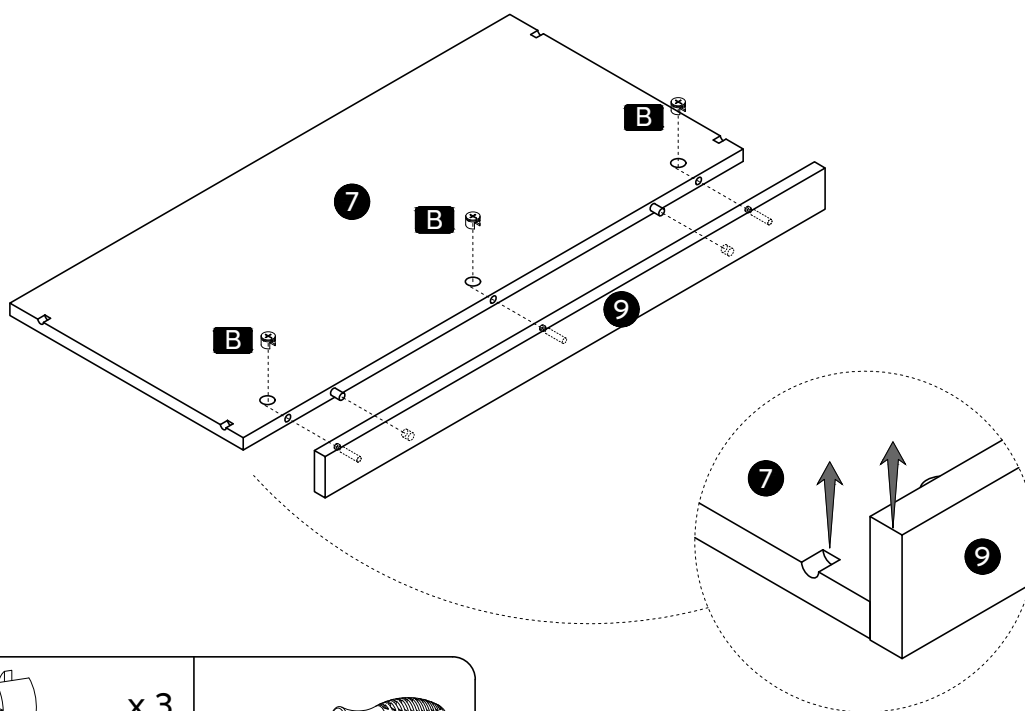

x 3

**B** Ø15mm

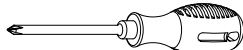

20

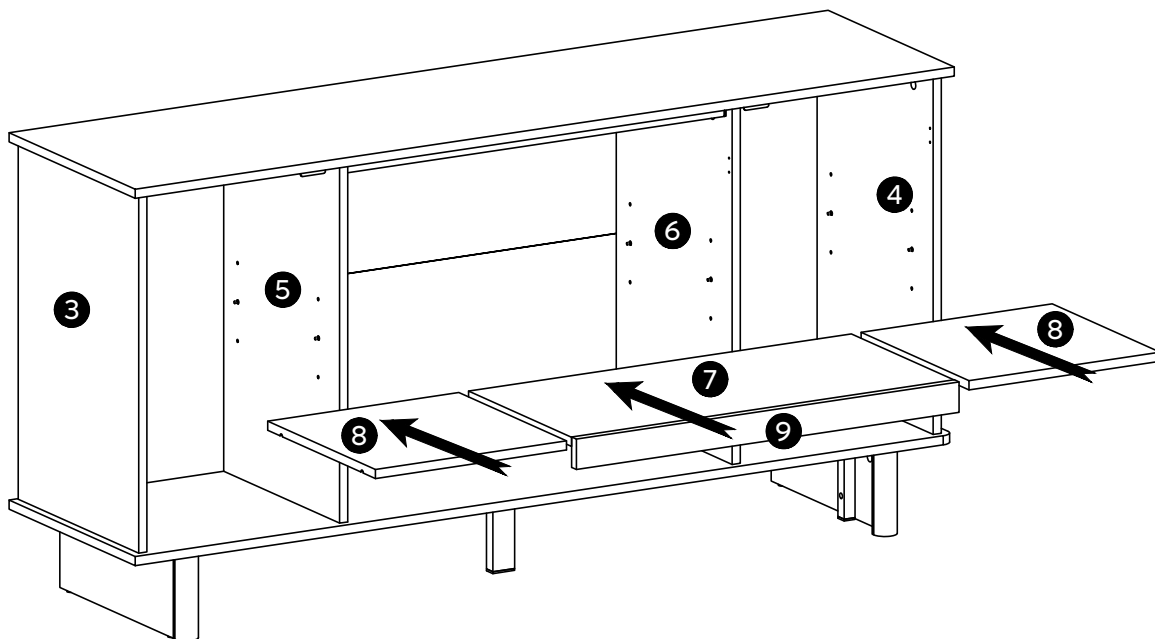

21

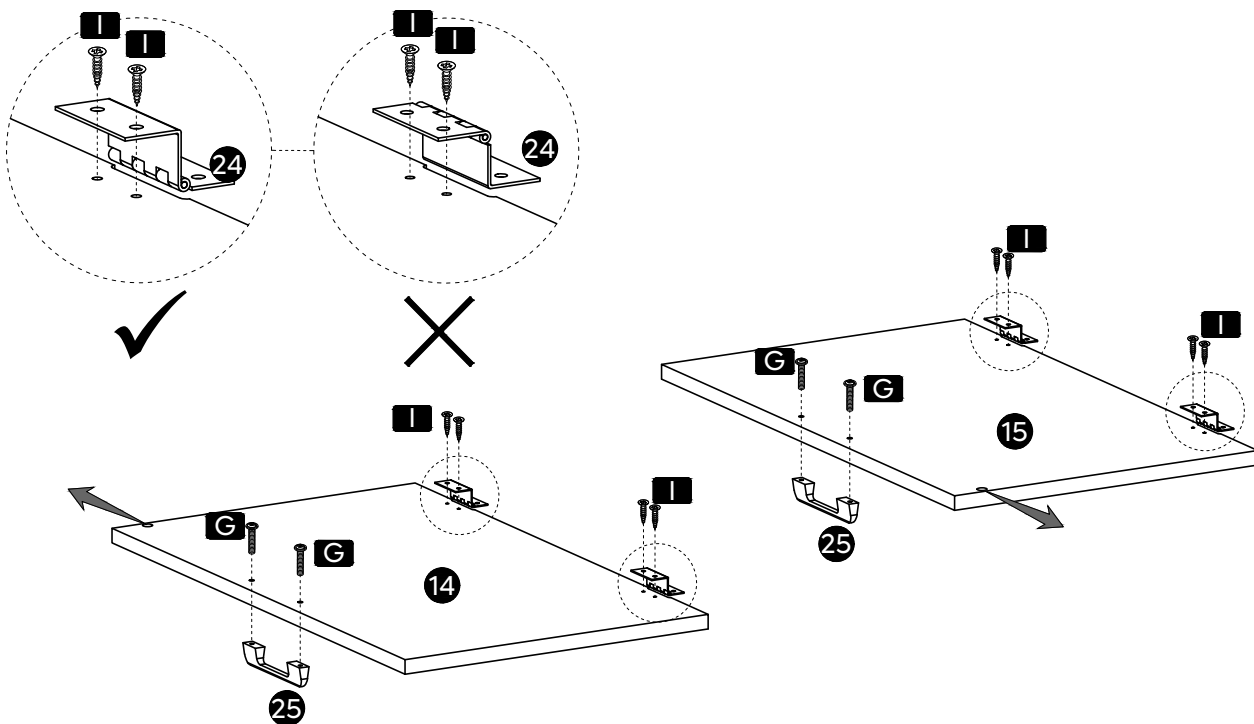

x 4



x 8

**G** M4x19mm

**I** ST3x14mm

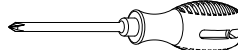

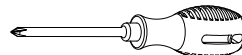
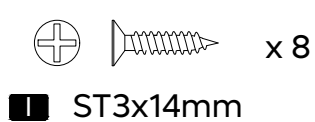
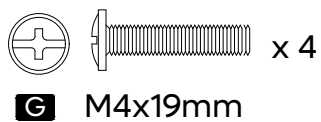
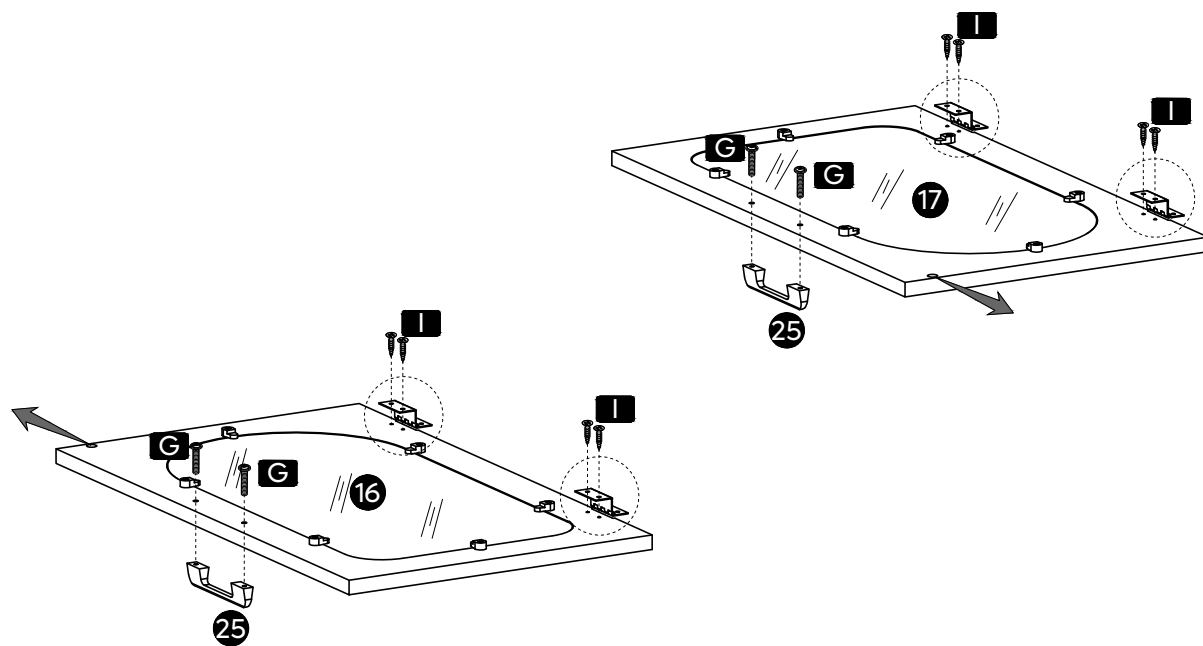
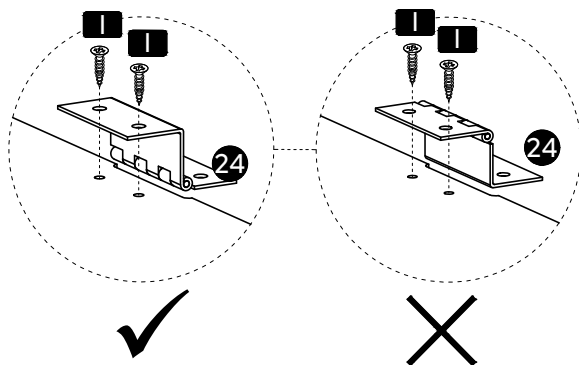

A

- ※ Two persons are needed.
- ※ Deux personnes sont nécessaires.
- ※ Zwei Personen sind erforderlich.
- ※ Sono necessarie due persone.
- ※ Se necesitan dos personas.
- ※ 두 사람이 필요합니다.
- ※ 必ず2人で作業してください。
- ※ 需要另1个人协助。

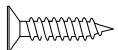
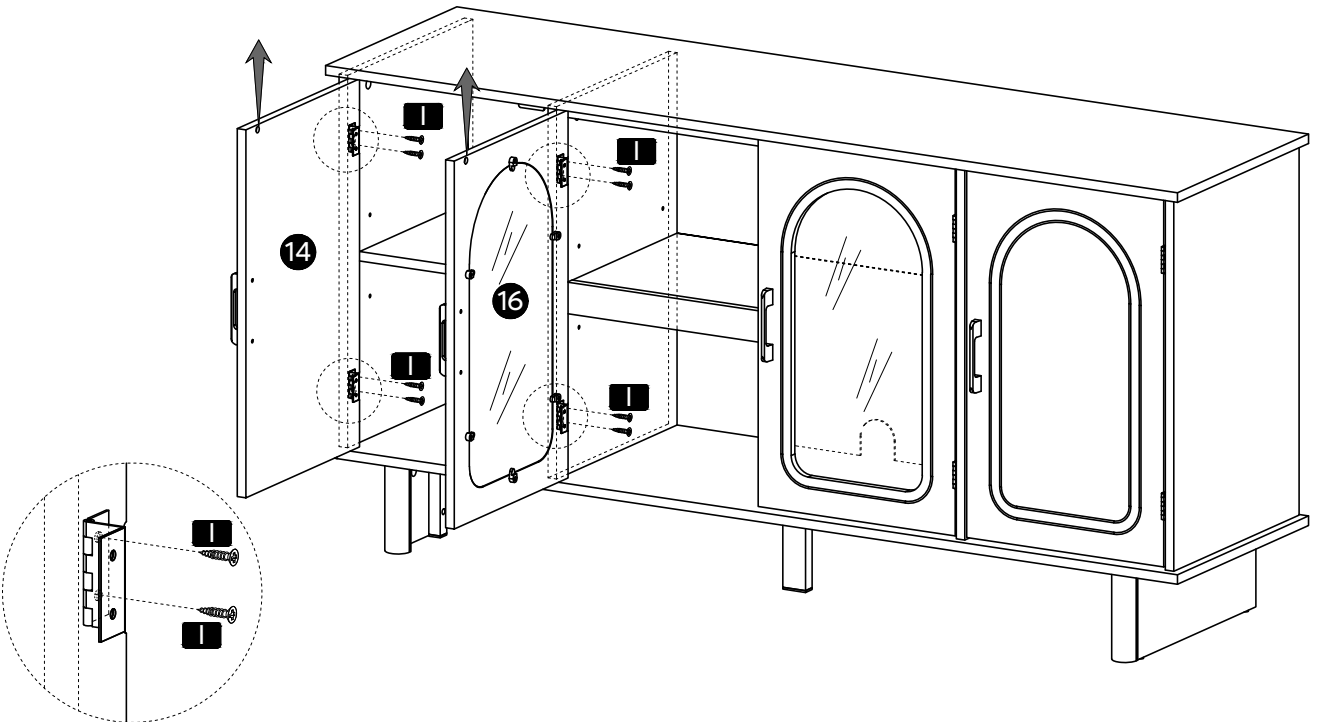
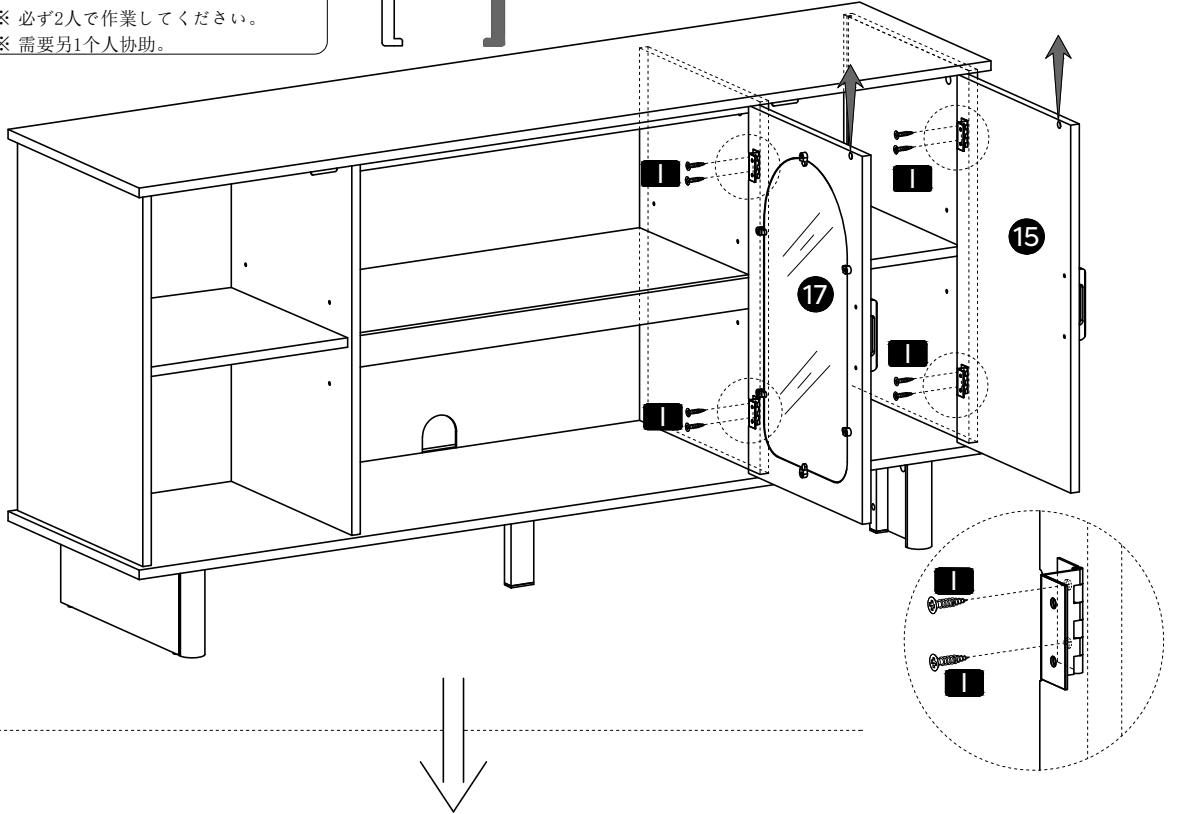
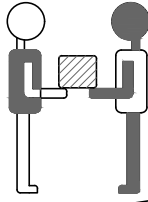

x 16

■ ST3x14mm

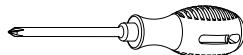

OR(ou/oder/o/o/또는/または/或者)

B

- ※ Two persons are needed.
- ※ Deux personnes sont nécessaires.
- ※ Zwei Personen sind erforderlich.
- ※ Sono necessarie due persone.
- ※ Se necesitan dos personas.
- ※ 두 사람이 필요합니다.
- ※ 必ず2人で作業してください。
- ※ 需要另1个人协助。

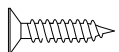
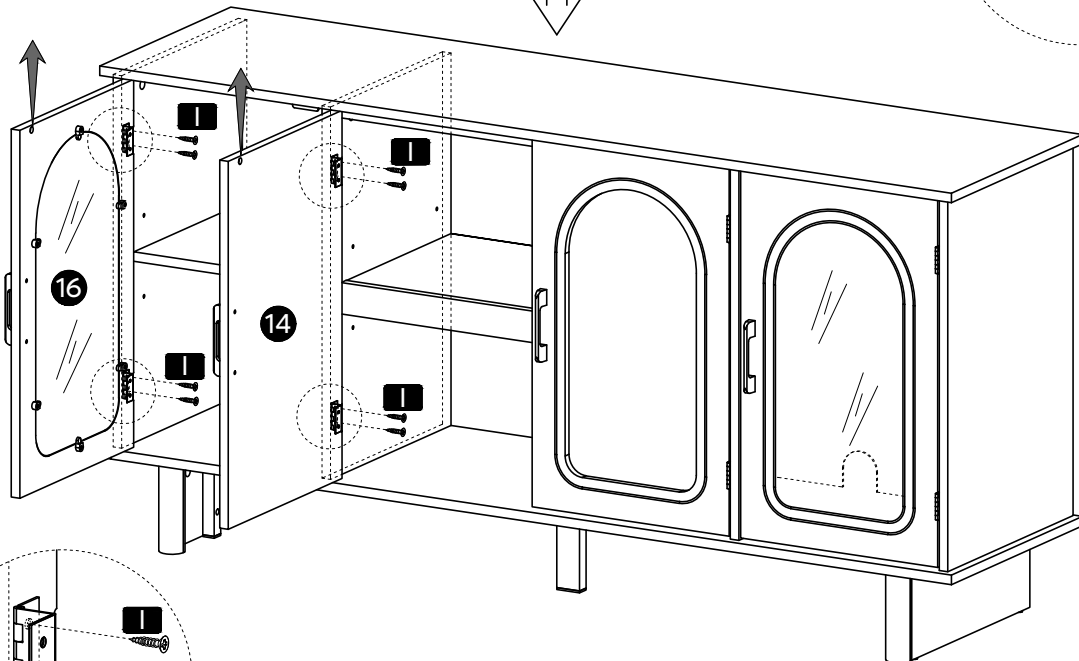
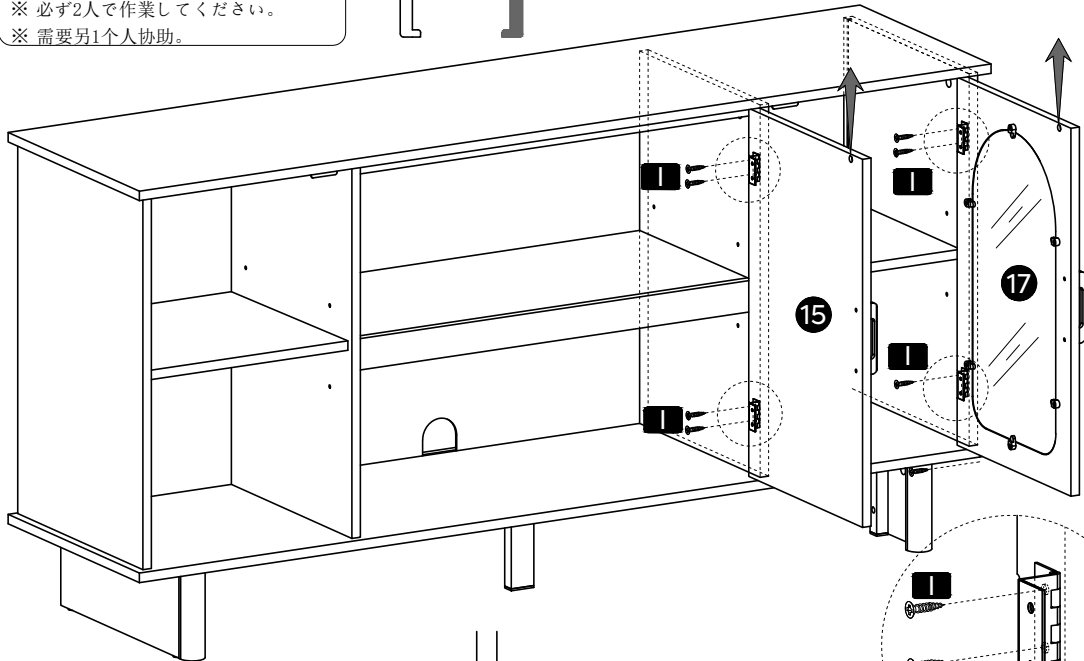
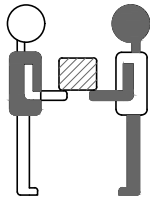

x 16

■ ST3x14mm

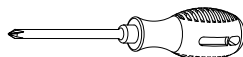

- ※ Back view.
- ※ Vue arrière.
- ※ Rückansicht.
- ※ Vista posteriore.
- ※ Vista trasera.
- ※ 후면 뷰.
- ※ バックビュー。
- ※ 背视图。

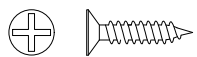
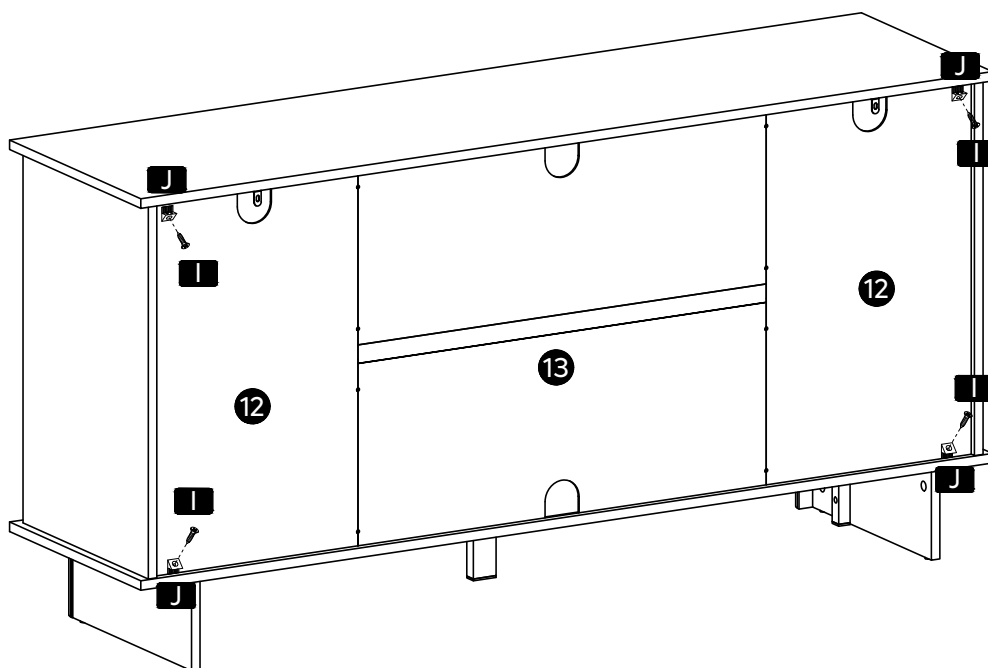
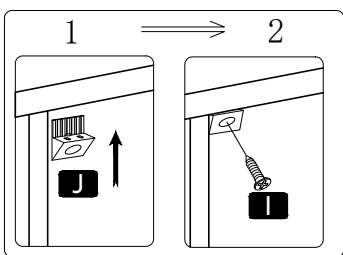

x 4

**I** ST3x14mm



x 4

**J**

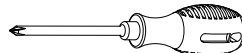

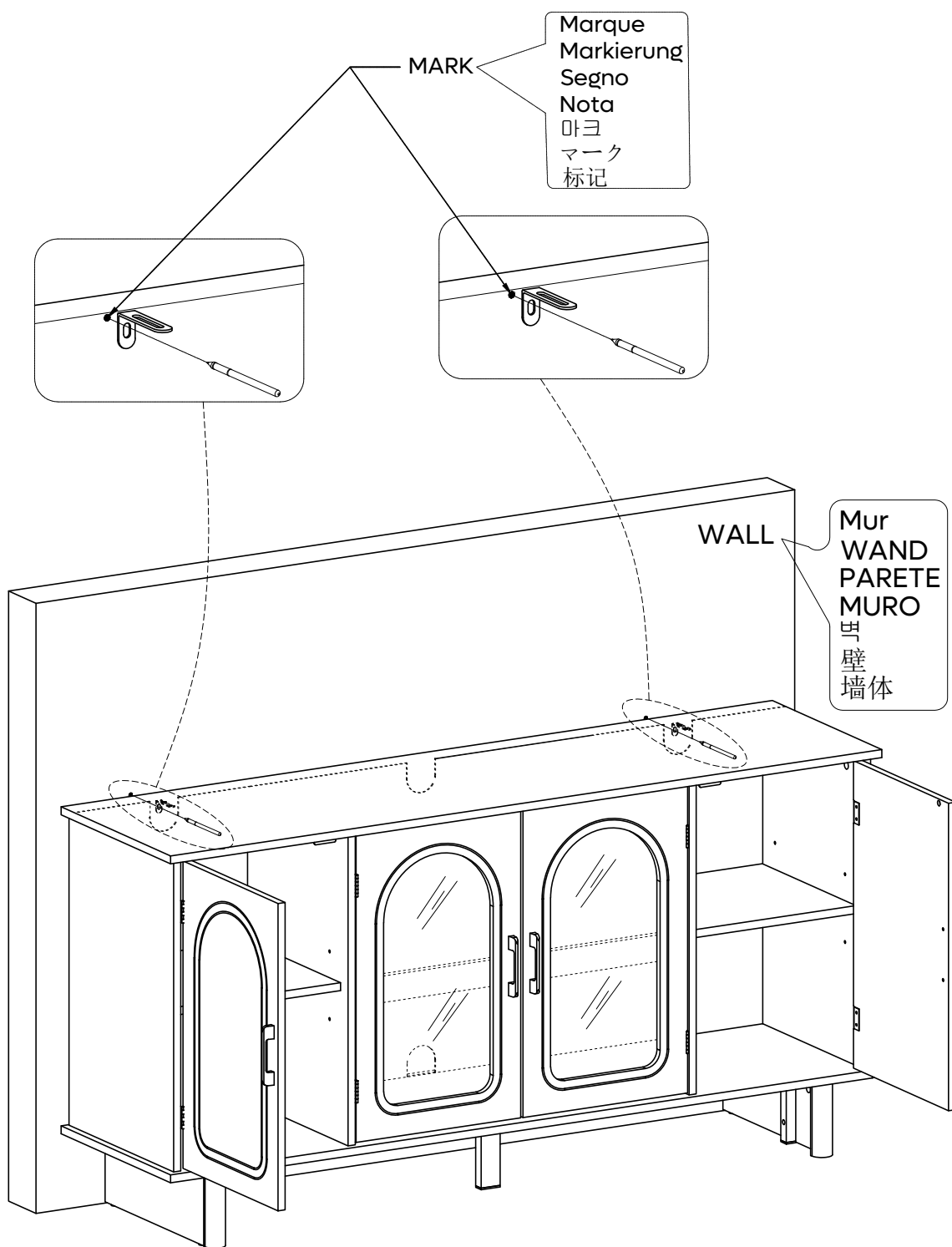

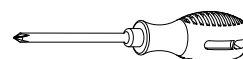
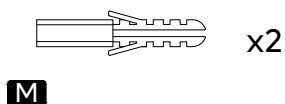
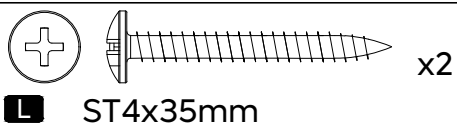
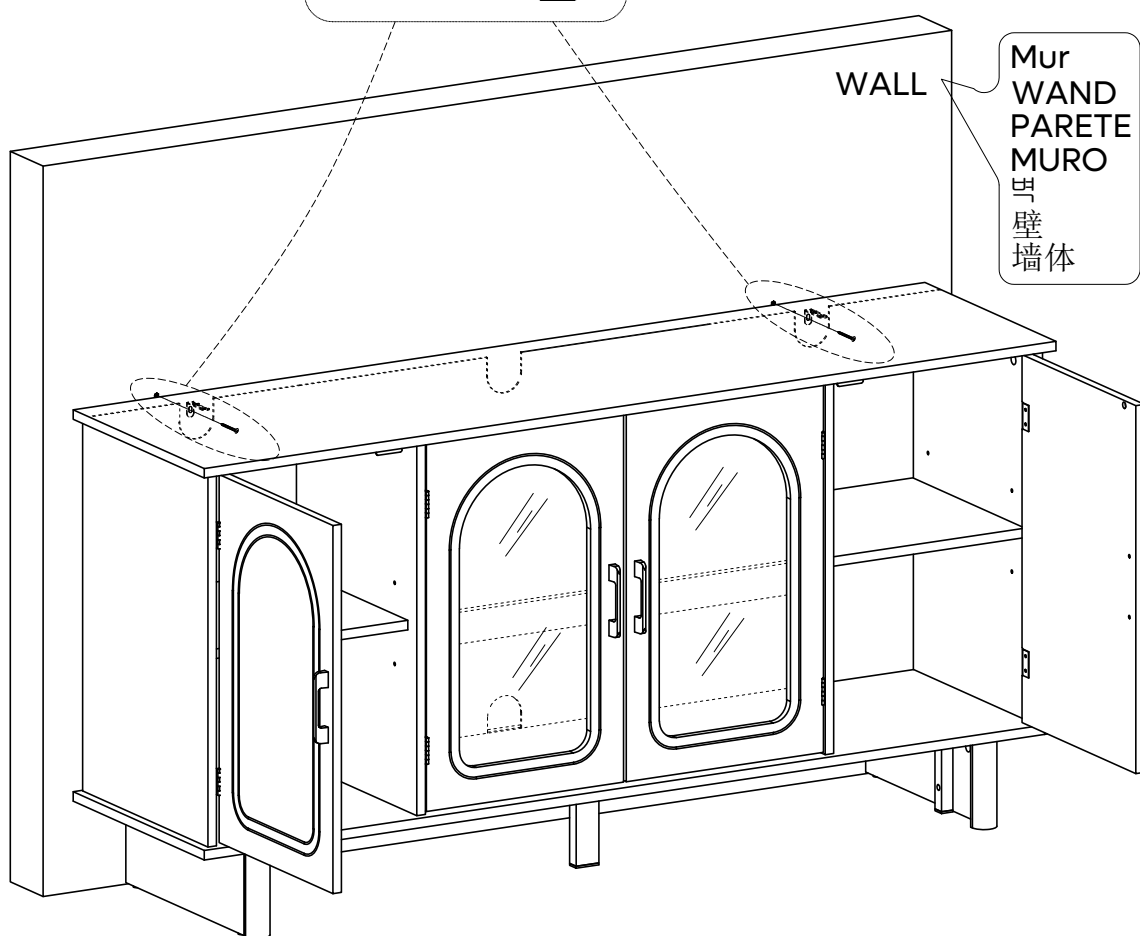
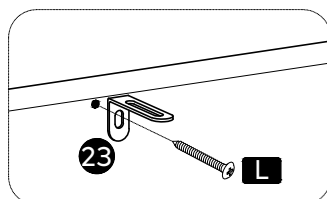
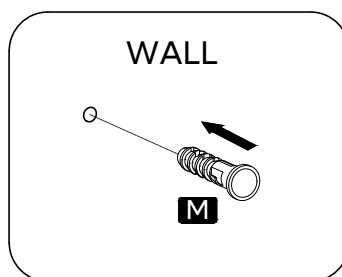
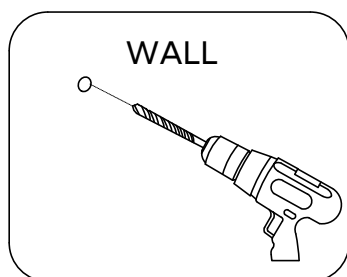

✳️ **Please fasten this item to wall for protection and safety.**

1. Drill 2 holes in the wall and insert "M" into holes.  
✳️ You may need to use rubber mallet for tapping "M".
2. Use "L" to attach "M" with "23".

✳️ **Veillez fixer ce buffet de salle à manger sur votre mur pour plus de protection et de sécurité.**

1. "M"ercez 2 trous dans le mur et insérez "M" dans les trous.  
✳️ Vous devrez peut-être utiliser un maillet en caoutchouc pour frapper "M".
2. Utilisez "L" pour connecter "M" avec "23".

✳️ **Bitte befestigen Sie diesen ArtiPel zum Schutz und zur Sicherheit an der Wand.**

1. Bohren Sie 2 Löcher in die Wand und setzen Sie die "M" in die Löcher ein.  
✳️ Möglicherweise müssen Sie einen Gummihammer zum Llopfen von "M" verwenden.
2. Verwenden Sie "L", um "M" mit "23" zu verbinden.

✳️ **Si prega di fissare questo articolo alla parete per protezione e sicurezza.**

1. "M"raticare 2 fori nella parete e inserire "M" nei fori.  
✳️ "M"otrebbe essere necessario usare un martello di gomma per fissare il pezzo "M".
2. Utilizzare "L" per collegare "M" con "23".

✳️ **Fi"l"e este elemento a la pared como medida de protección y seguridad.**

1. Taladre 2 orificios en la pared e inserte el tornillo "M" en los orificios.  
✳️ Es posible que tenga que utilizar el mazo de goma para golpear "M".
2. Utilice "L" para unir "M" con "23".

✳️ 보호와 안전을 위해 이 물건을 벽에 고정하십시오.

1. 벽에 구멍 2 개를 뚫고 "M" 를 구멍에 삽입합니다.  
✳️ 고무망치로 "M" 를 두드려야 할 수도 있습니다.
2. "L" 를 사용하여 "M" 를 "23"에 연결합니다.

✳️ **安全のために、オープンシェルフを壁に固定してください。**

1. 壁に 2 つ穴を開け、"M" を穴に差し込む。  
✳️ "M" を叩くにはラバーハンマーが必要かもしれません。
2. "L" を使用し、"M" と"23"を接続してください。

✳️ **请将此产品固定在墙上以防护和安全。**

1. 在墙上钻 2 个孔，然后将 "M" 插入孔中。  
✳️ 您可能需要使用橡皮槌敲击 "M" 。
2. 用 "L" 将 "M" 与 配件"23" 连接。

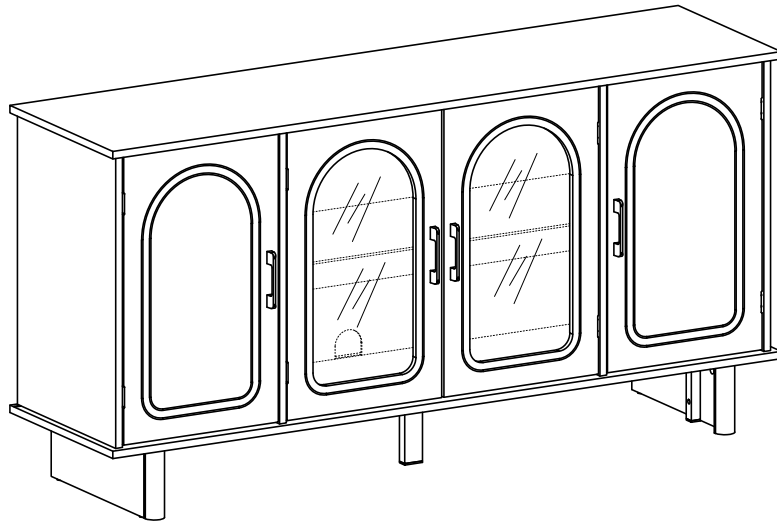

## WARNING

**Children have died from furniture tipover. To reduce the risk of furniture tipover:**

- DO NOT defeat or remove the drawer interlock system; it is an important stability and safety system.
- NEVER allow children to stand, climb or hang on drawers, doors, or shelves.
- NEVER put a TV on this product.
- NEVER open more than one drawer at a time.
- ALWAYS install Anti-tip device provided.
- Place heaviest items in the lowest drawers.

*This is a permanent label.  
Do not remove!*

