

SAFETY INFORMATION



Please read and understand this entire manual before attempting to assemble, operate or install the product.



WARNING

- Some steps are more easily handled with two adults.

CAUTION

- Before assembly and/or installation, carefully unwrap all parts.
- Locate and set aside the hardware kit before discarding packaging.
- Use care when assembling your new product. Take your time and follow assembly instructions closely.

INFORMATION DE SÉCURITÉ



Assurez-vous de lire et de comprendre l'intégralité du présent manuel avant de tenter d'assembler, d'utiliser ou d'installer le produit.



AVERTISSEMENT

- Certaines étapes sont plus faciles à effectuer avec l'aide.

MISE EN GARDE

- Avant l'assemblage et/ou l'installation, vous devez déballer minutieusement toutes les pièces.
- Localisez et mettez de côté le jeu de quincaillerie avant de jeter l'emballage.
- Soyez vigilant lorsque vous assemblez le nouveau produit. Prenez votre temps et suivez attentivement ces instructions.

INFORMACIÓN DE SEGURIDAD



Lea y comprenda completamente este manual antes de intentar ensamblar, usar o instalar el producto.



ADVERTENCIA

- Algunos de los pasos se pueden realizar con mayor facilidad entre dos adultos.

PRECAUCIÓN

- Antes del ensamblaje y/o instalación, desenvuelva cuidadosamente todas las piezas.
- Localice y separe el equipo de accesorios antes de desechar el embalaje.
- Tenga cuidado al ensamblar el nuevo producto. Tómese su tiempo y siga detenidamente las instrucciones de ensamblaje.

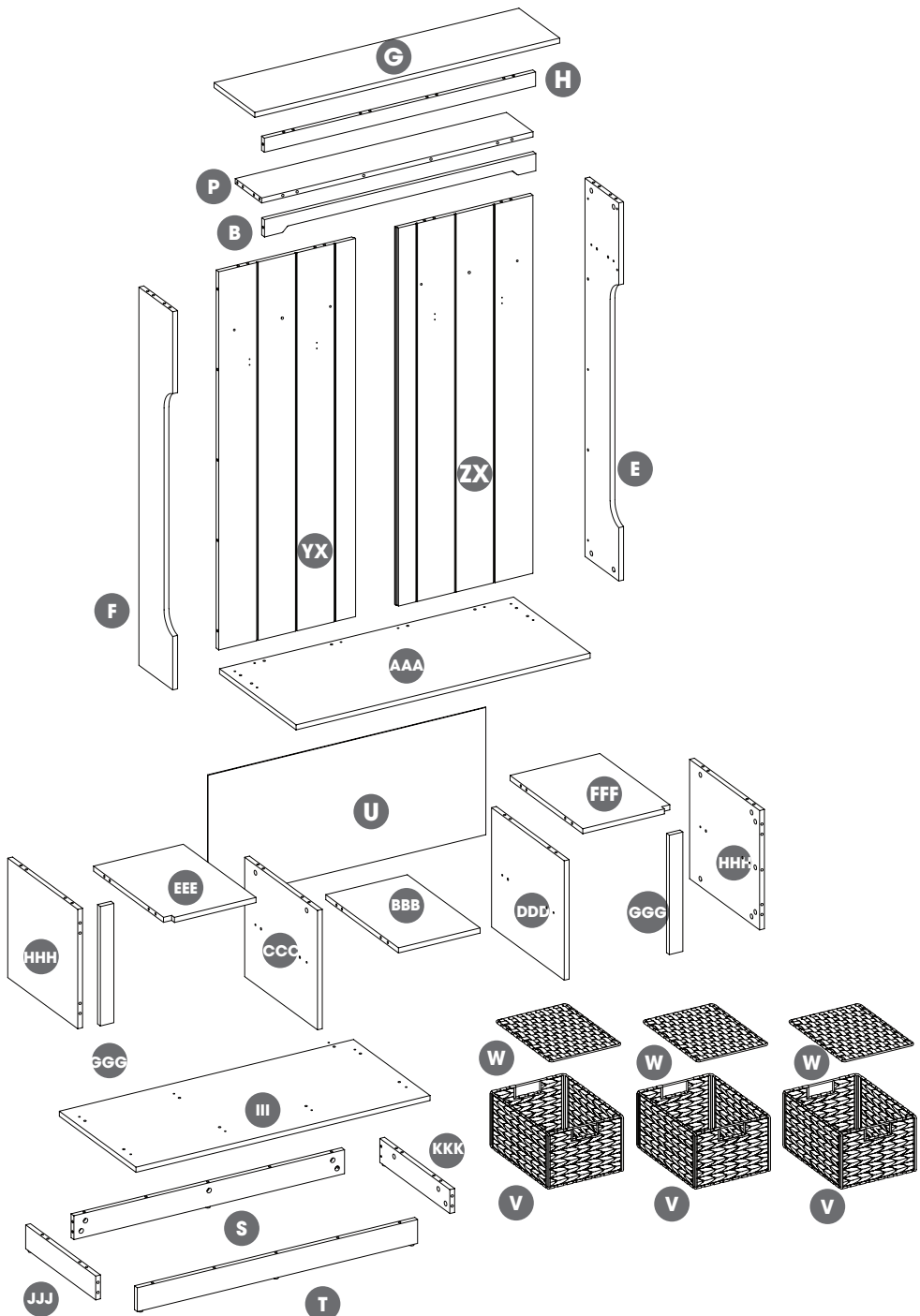

MAXIMUM LOAD
15.9 kg / 35 lbs
CHARGE MAXIMALE DE
15.9 kg / 35 lbs
CARGA MÁXIMA
15.9 kg / 35 lbs

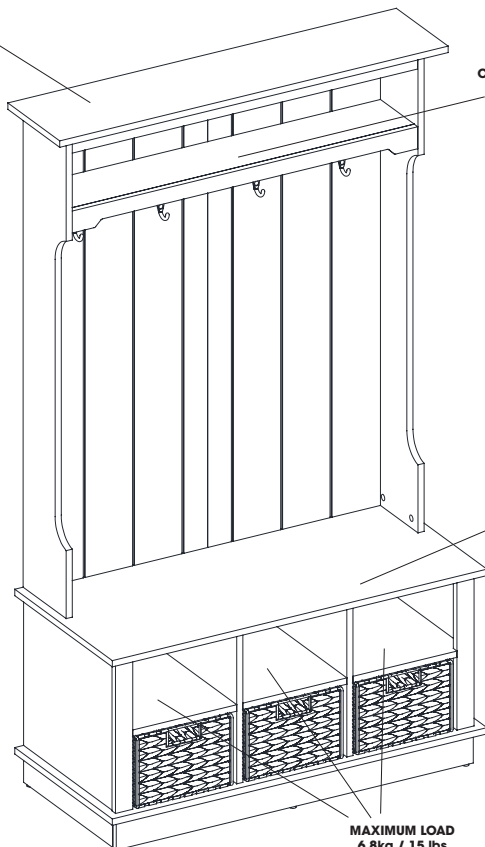

MAXIMUM LOAD
13.6 kg / 30 lbs
CHARGE MAXIMALE DE
13.6 kg / 30 lbs
CARGA MÁXIMA
13.6 kg / 30 lbs

MAXIMUM LOAD
158 kg / 350 lbs
CHARGE MAXIMALE DE
158 kg / 350 lbs
CARGA MÁXIMA
158 kg / 350 lbs

MAXIMUM LOAD
6.8kg / 15 lbs
CHARGE MAXIMALE DE
6.8kg / 15 lbs
CARGA MÁXIMA
6.8kg / 15 lbs



WARNING

For use with most flat panel televisions weighing 158 kg / 350 lbs or less. Usage with televisions or loads heavier than the maximum weights specified may result in instability causing tip over resulting in death or serious injury.

ATTENTION

Destiné à la plupart des téléviseurs à écran flat panel pesant 158 kg / 350 lbs ou moins. EEE'utilisation avec des téléviseurs ou des charges dont le poids dépasse les valeurs spécifiées peut entraîner l'instabilité et le basculement pouvant provoquer la mort ou des blessures graves.

PRECAUCIÓN

Para usar con la mayoría de televisiones de flat panel, con peso de 158 kg / 350 lbs o inferior. Colocar televisores o cargas mayores que los pesos máximos especificados puede generar inestabilidad y, en consecuencia, desplomes que pueden causar la muerte o lesiones graves.

AA

[x76]



PH-KDBZNC001

BB

[x84]



PH-KDCZNC001

CC

[x4]



PH-SB6857-CC

DD

[x72]



Ø8x30mm
PH-DWLNTL001

EE

[x8]



Ø3.5 x15mm
PH-SCRNKL008

FF

[x4]



K7070

GG

[x4]



Ø4x50mm
PH-SCRBLK006

HH

[x36]



PH-KDPXXX001

II

[x16]

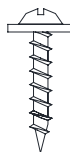

Ø3x16mm
PH-SCRZNC001

LL

[x1]



PH-FTRHH510

MM

[x4]

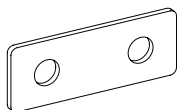

PH-SB6857-MM

NN

[x8]



PH-BLTBLK002

ATTENTION: Follow instructions in the order they are given below. This will ensure that your product is properly assembled.

ATTENTION: Suivre les instructions dans l'ordre donné ci-dessous. Cela vous assurera d'assembler correctement le produit.

ATENCIÓN: Siga las instrucciones en el orden que se indica a continuación. Esto asegurará que su producto se ensamble correctamente.

ATTENTION: To reduce the risk of damage to your furniture, please lay down a blanket, cloth, or cardboard on the floor prior to assembly.

ATTENTION: Para reducir el riesgo de daño a sus muebles, por favor coloque una manta, tela o cartón en el suelo antes del montaje.

ATENCIÓN: Pour réduire le risque d'endommager vos fournitures, veuillez les poser sur un tapis, un tissu ou un carton sur le sol avant l'assemblage.

1

DD



[x2]

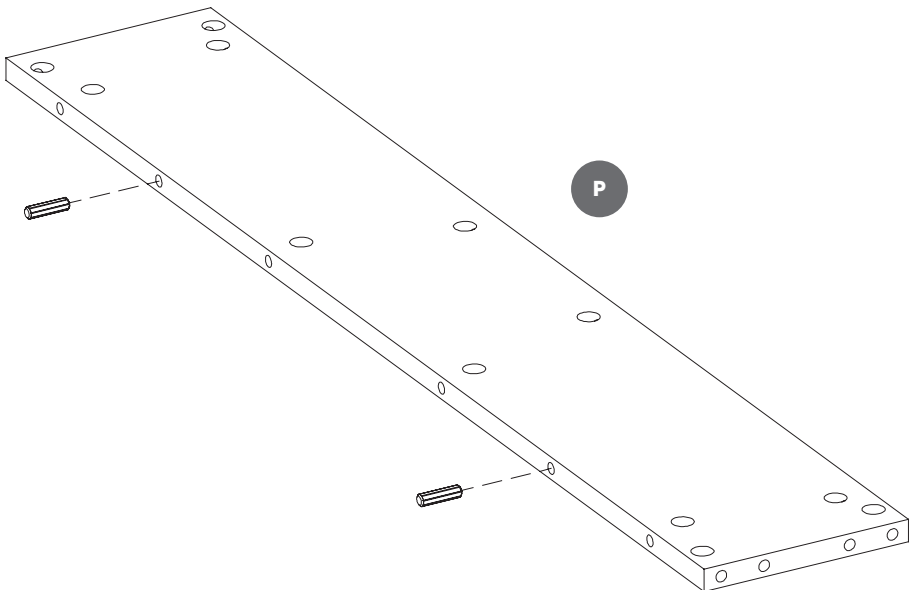

2

AA



[x4]

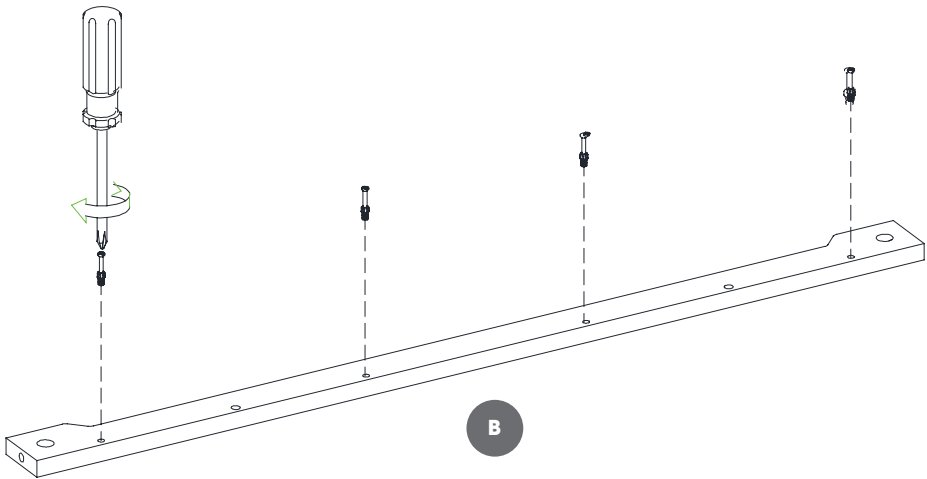

3

BB



[x4]

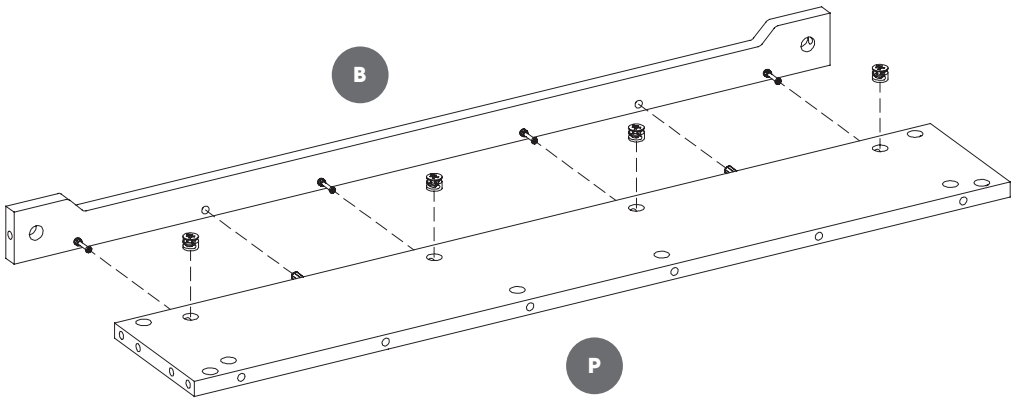
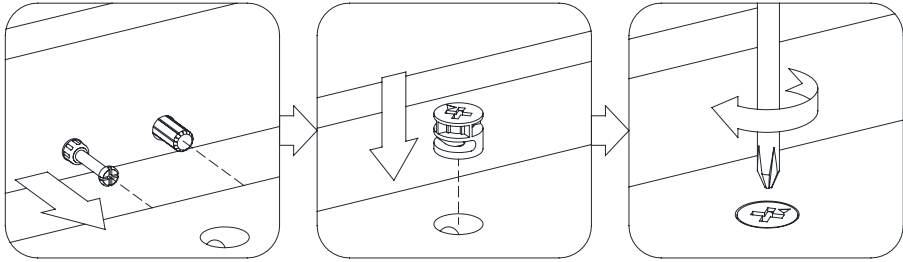

4

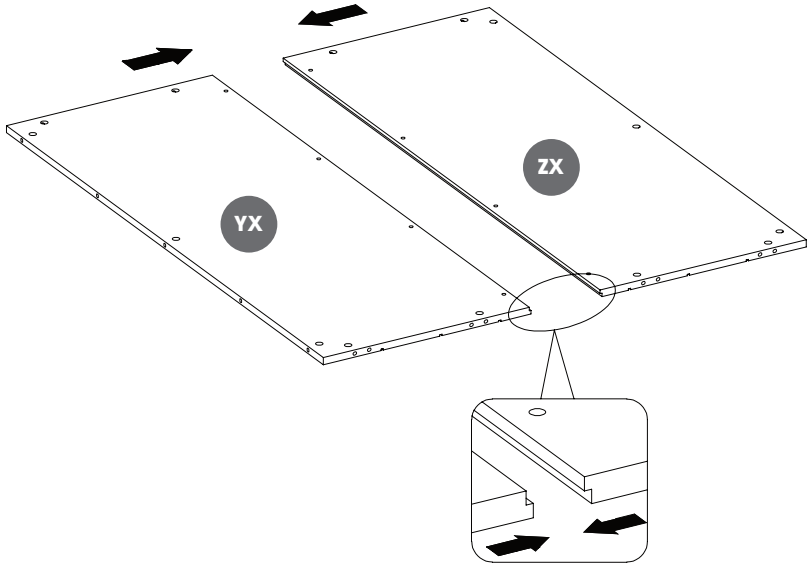

5

MM

NN

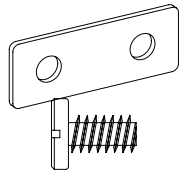

[x4]

[x8]

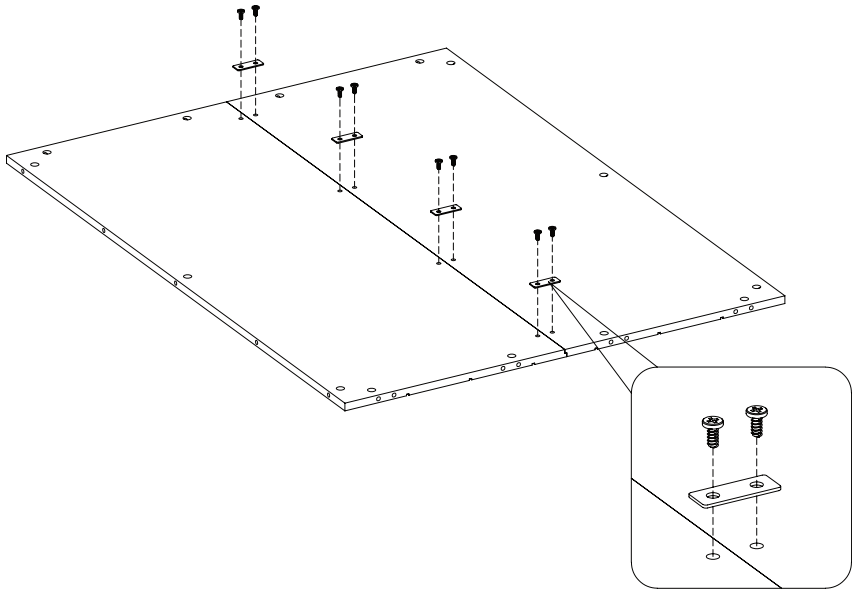

6

AA

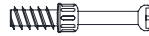

[x4]

DD



[x2]

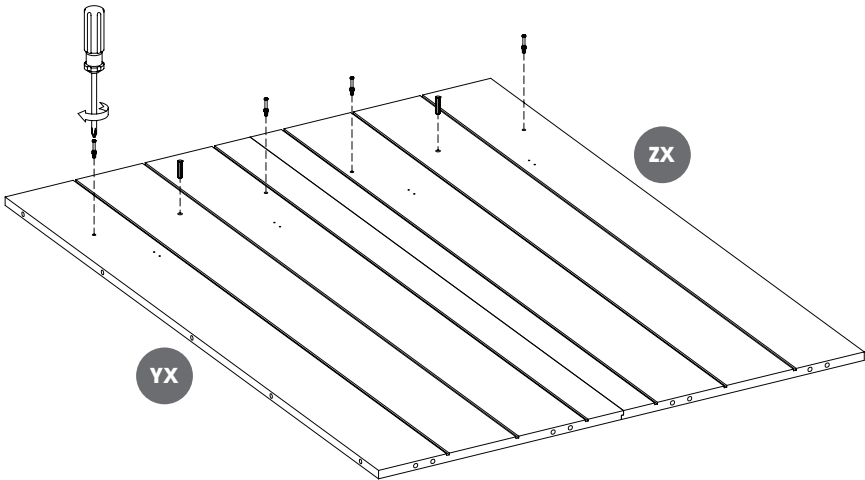

7

BB



[x4]

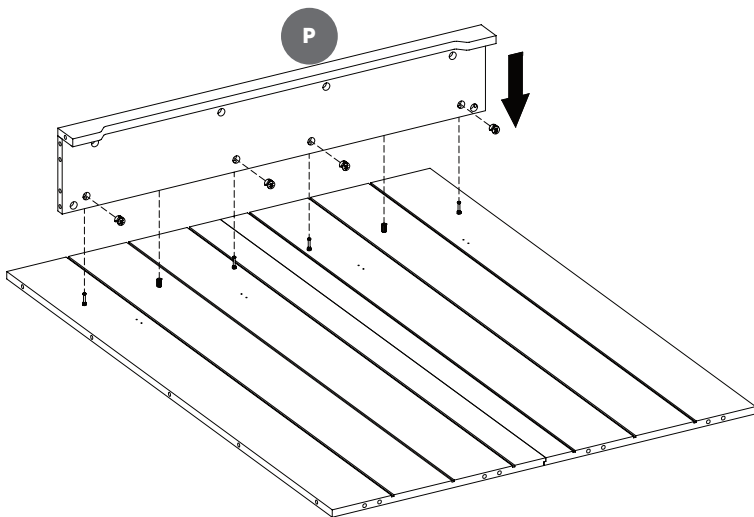
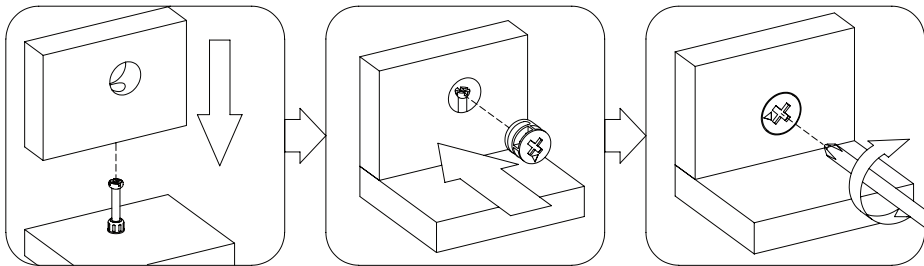

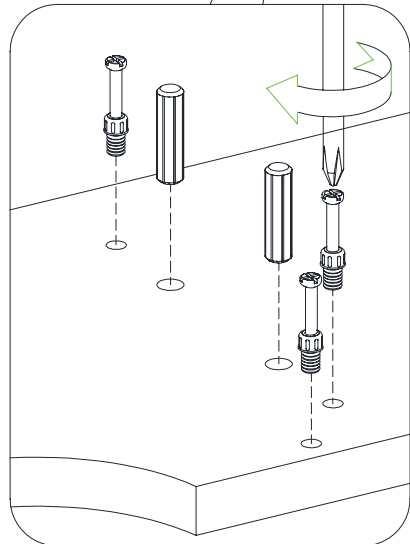
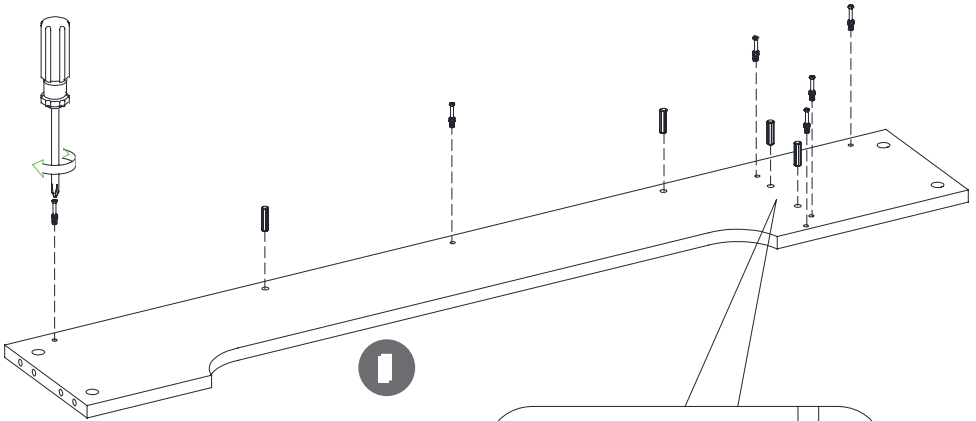
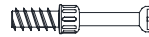

9

BB



[x3]

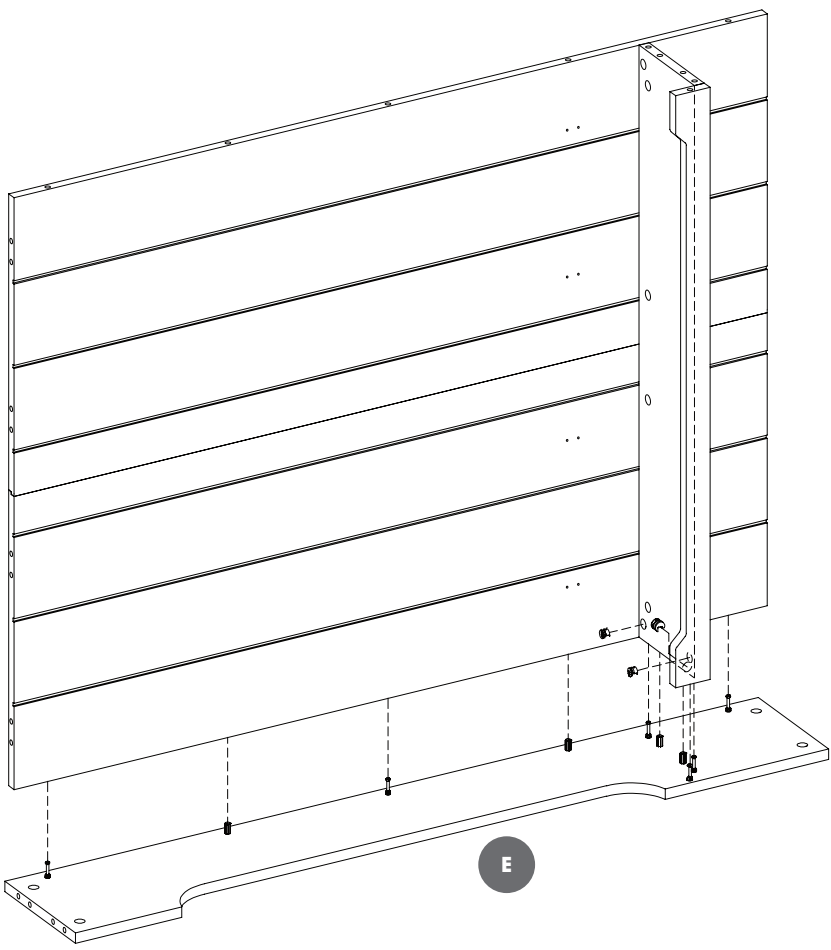
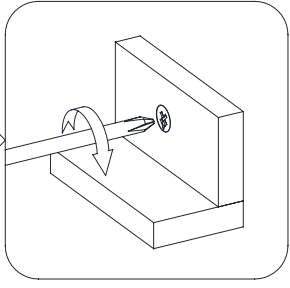
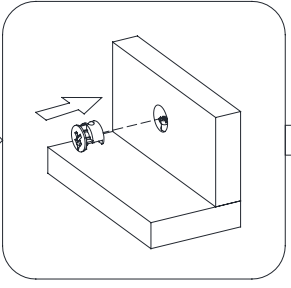
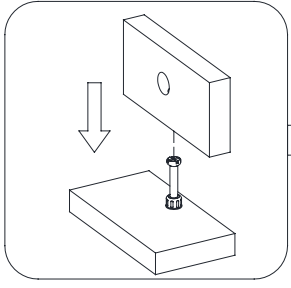

10

DD



[x4]

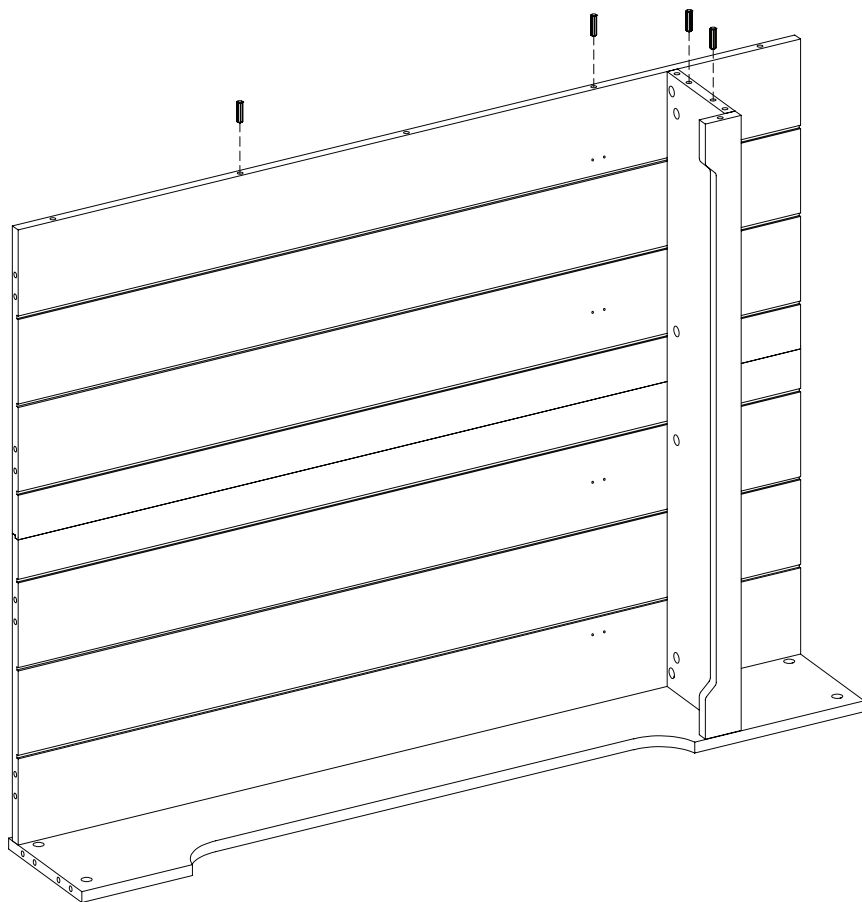

11

AA



[x6]

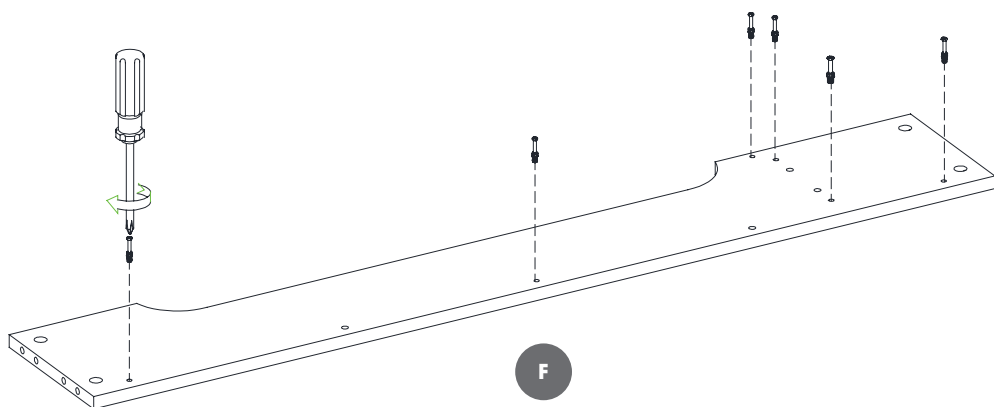

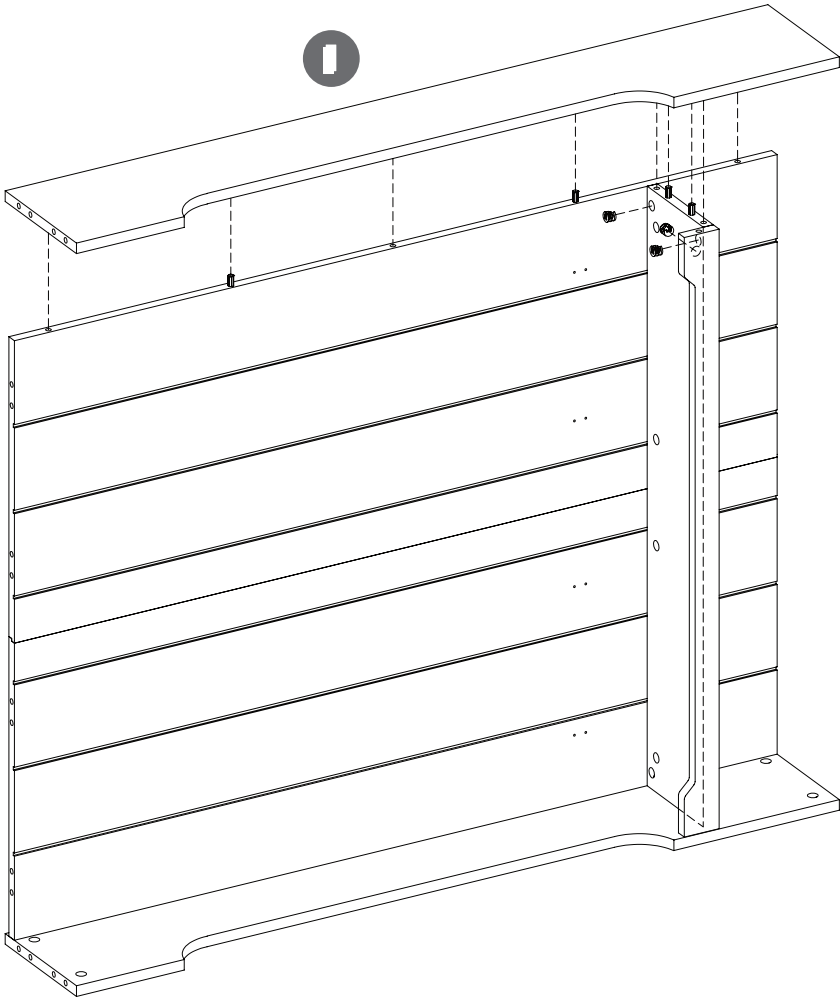
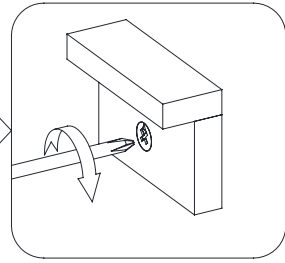
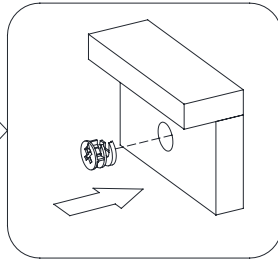
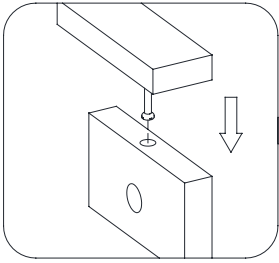

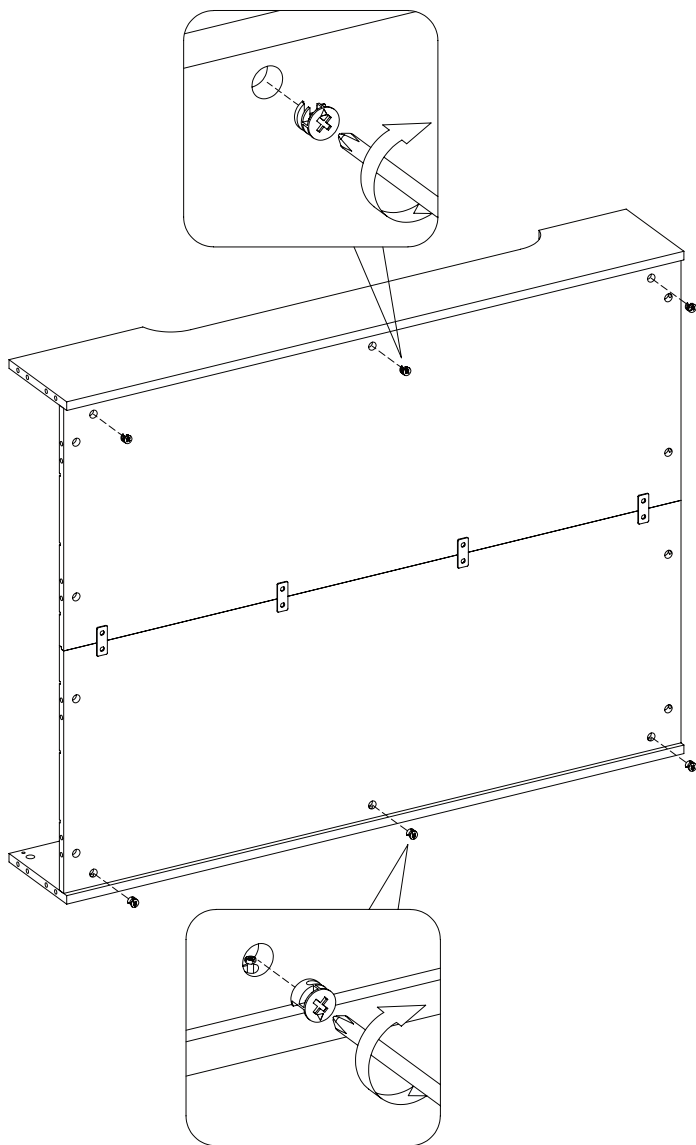

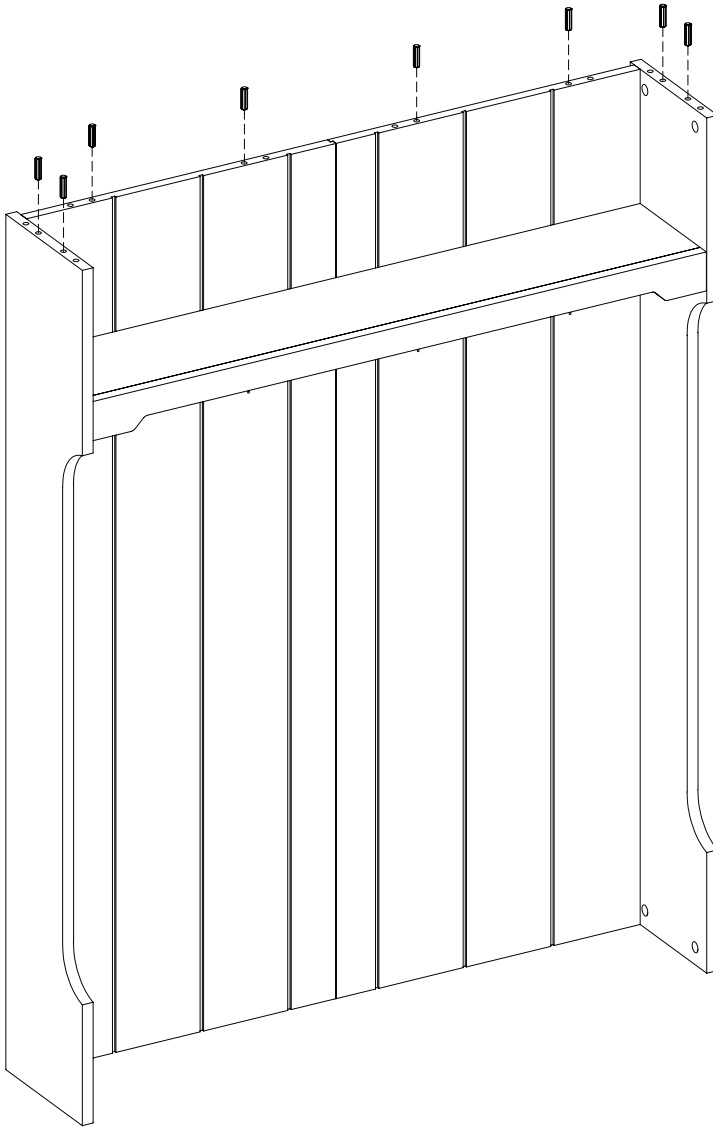
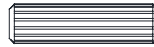

15

AA

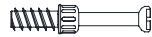

[x12]

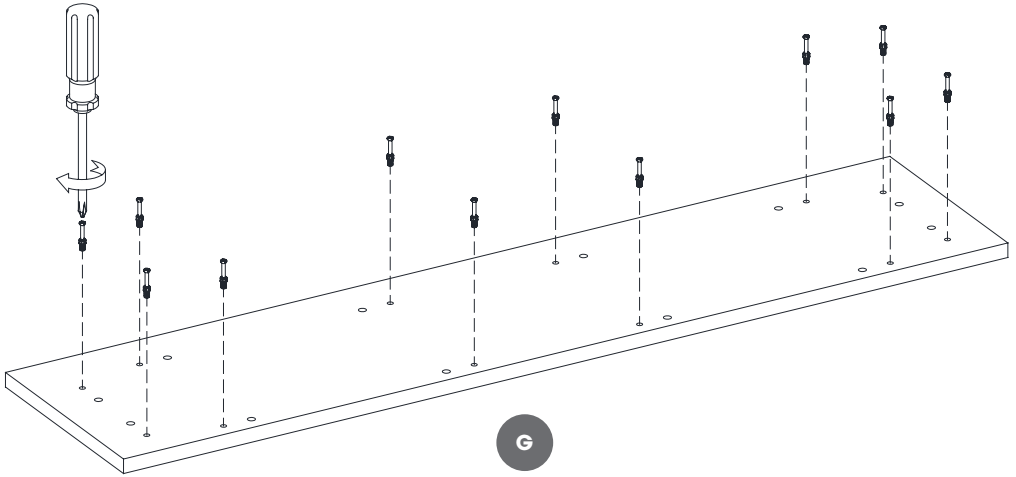

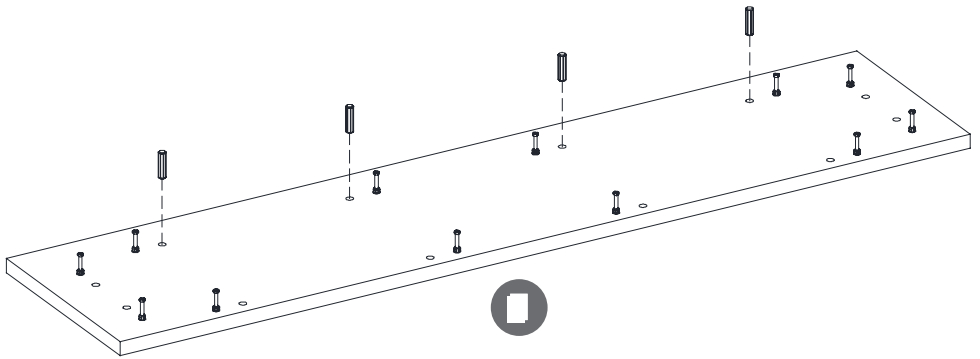

17

BB



[x4]

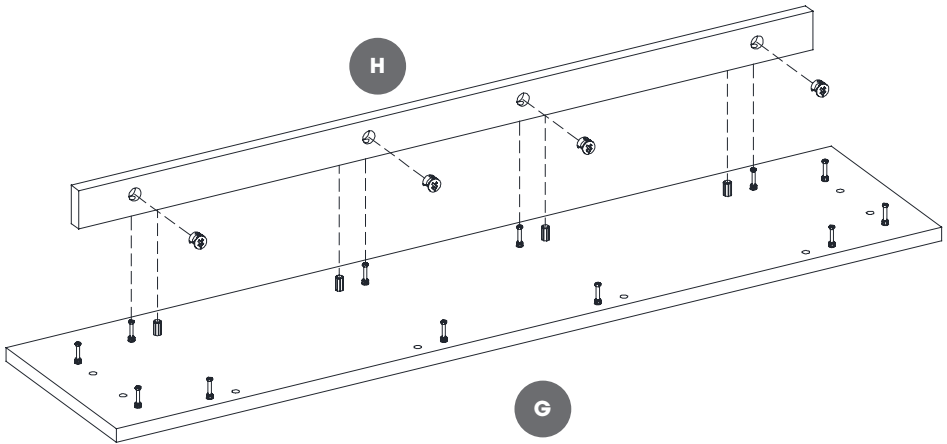
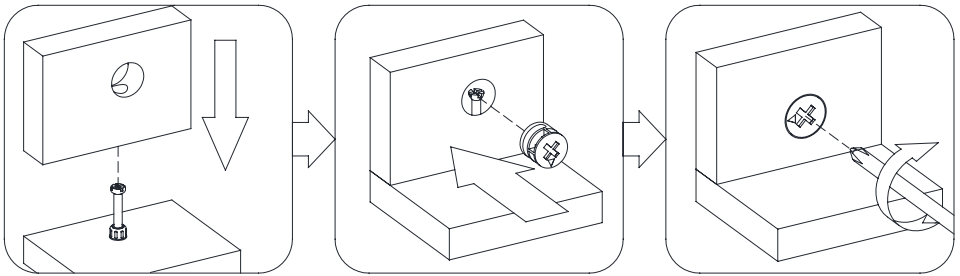

18

BB



[x4]

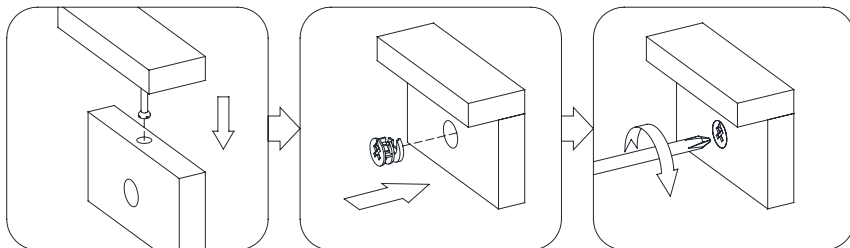

G

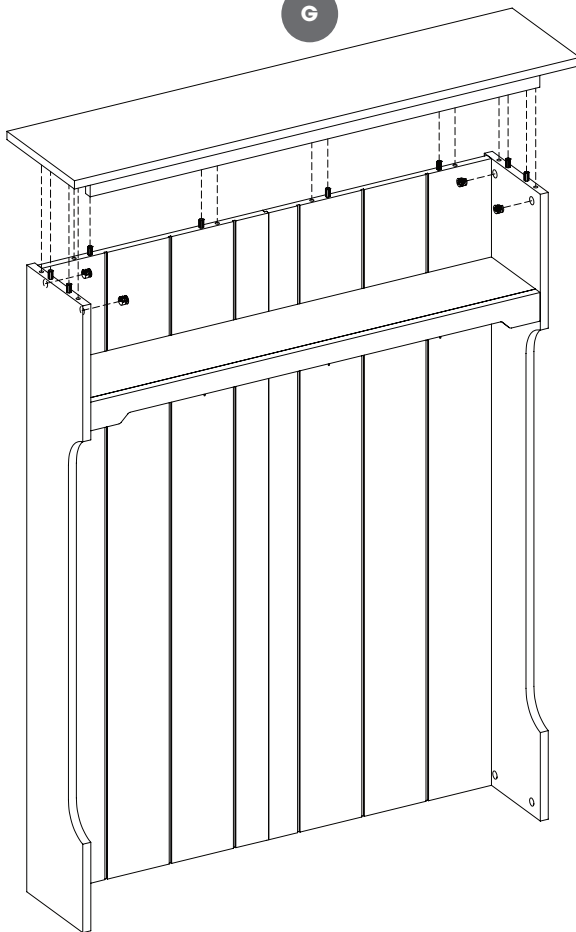

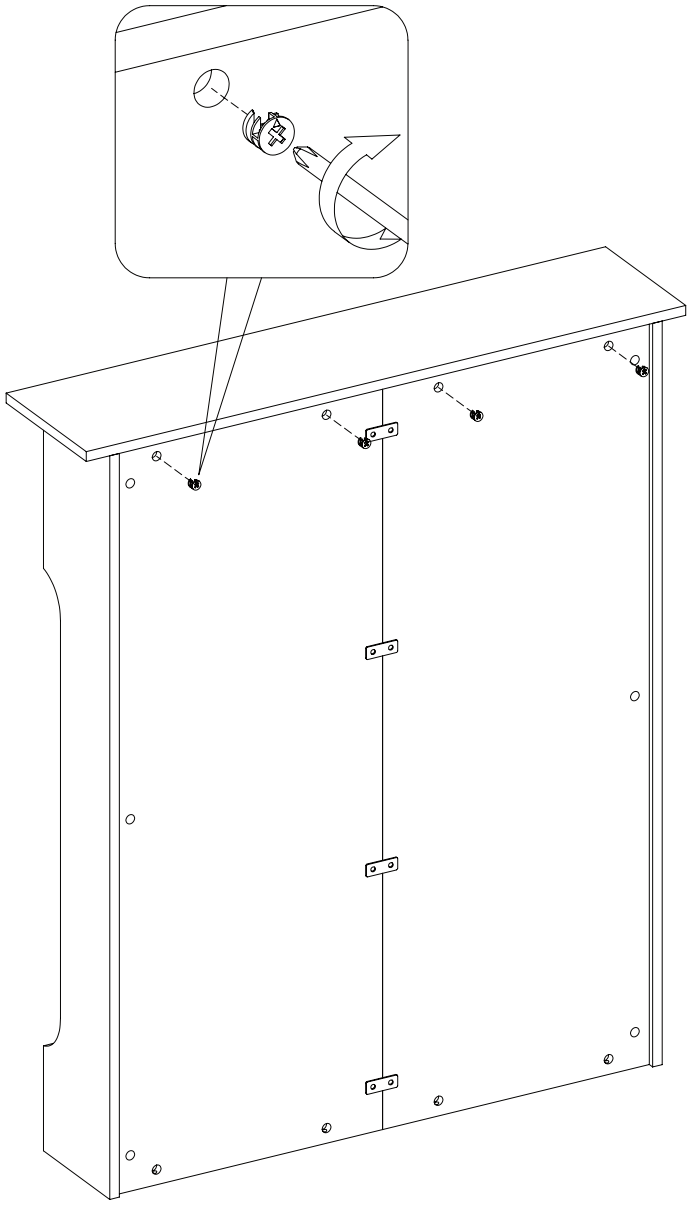

20

FF



[x4]

EE

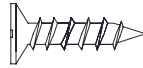

[x8]

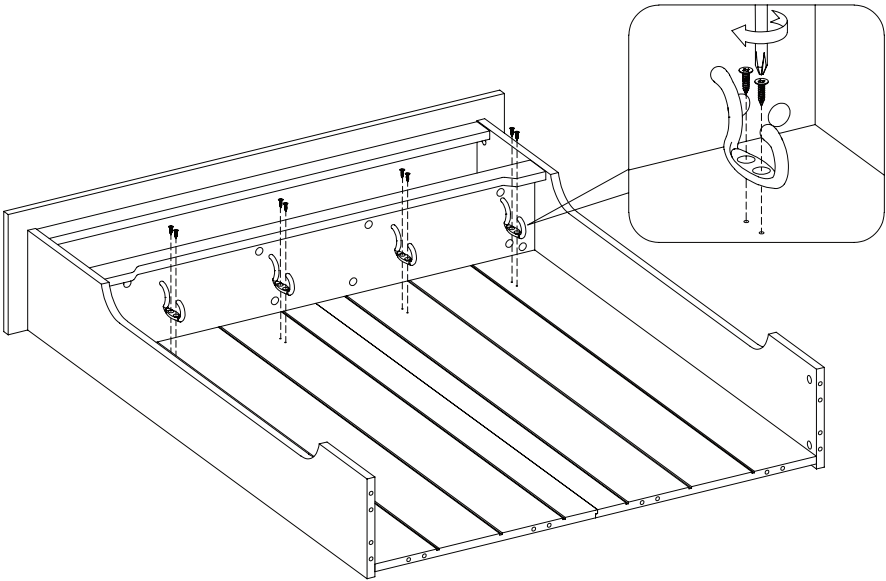

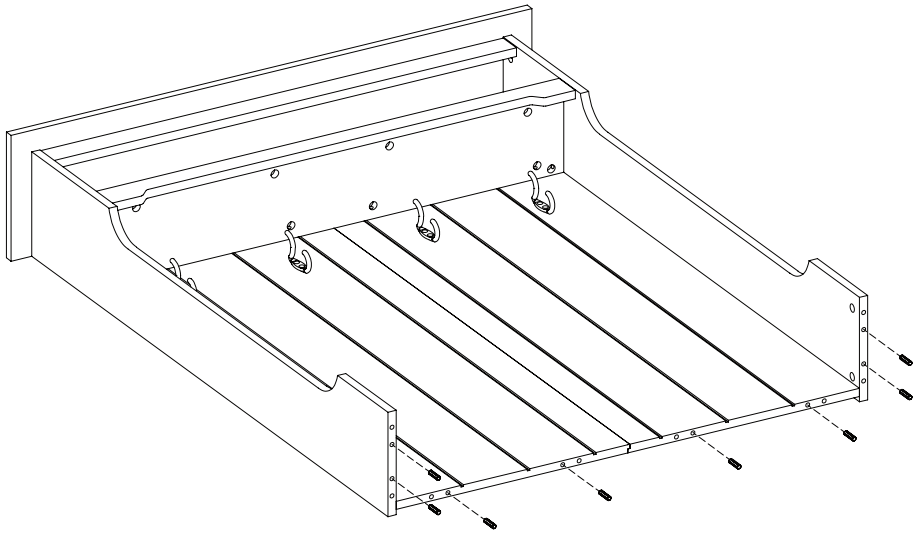
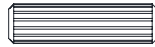

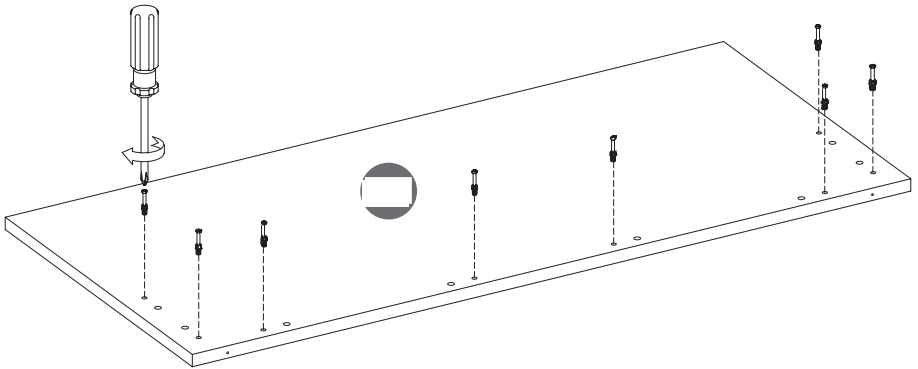

23

BB



[x4]

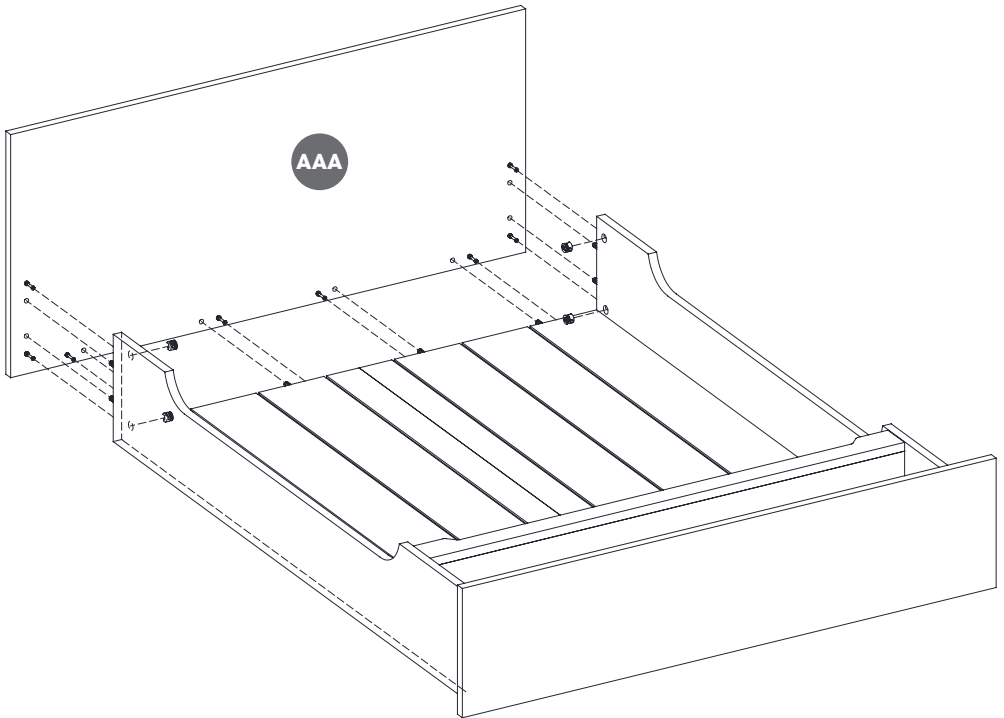
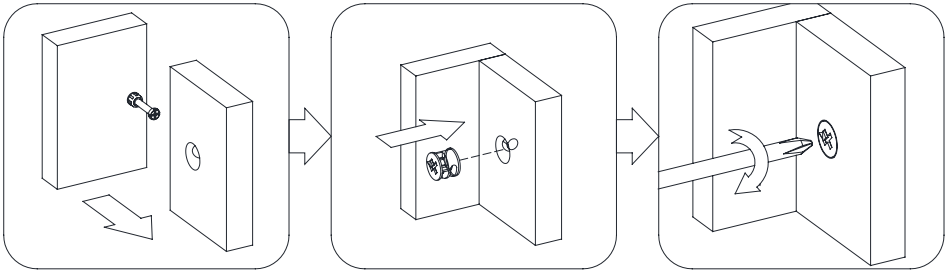

24

AA

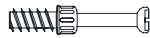

[x8]

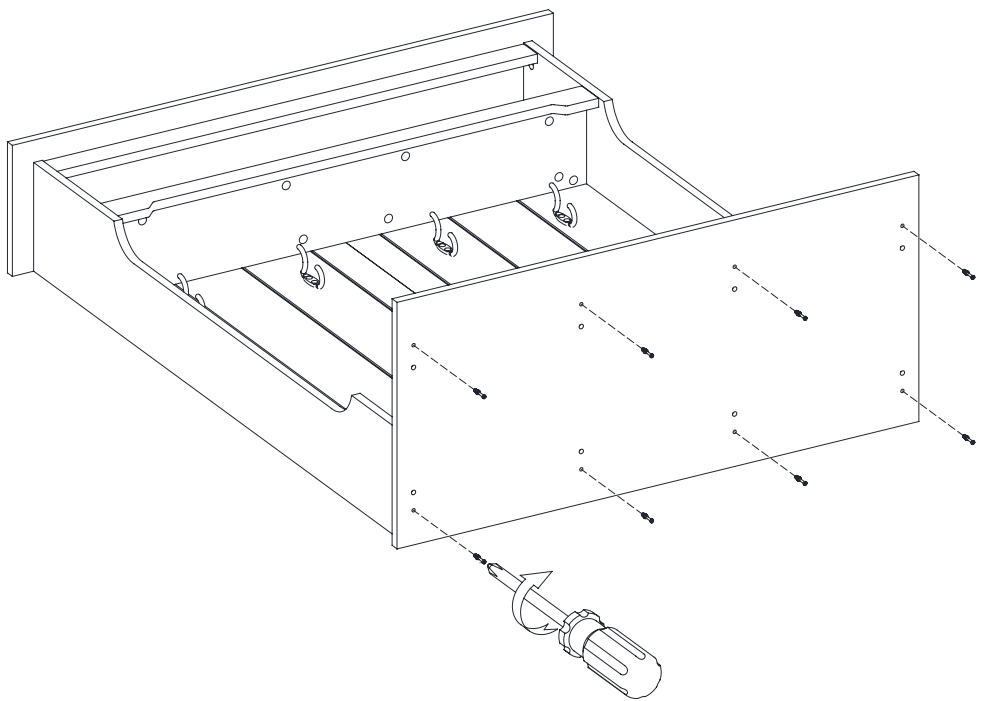

25

CC [x4]



BB [x4]

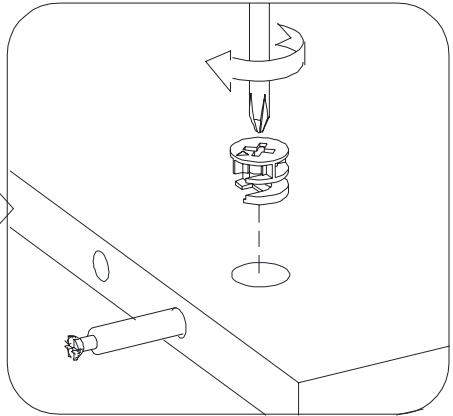
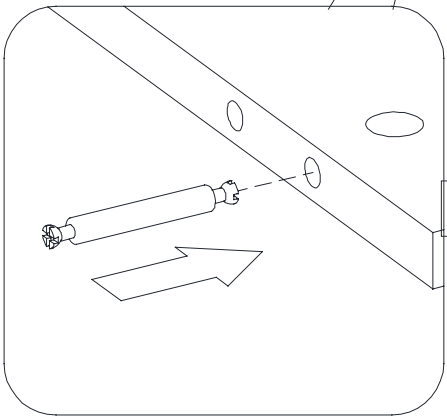
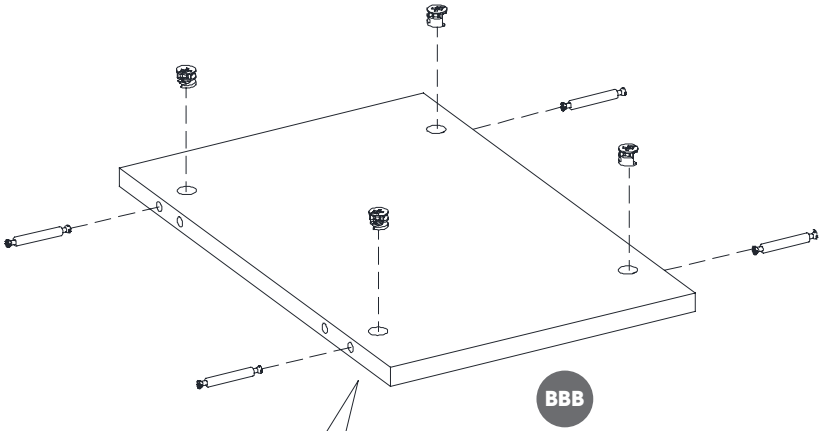

26

DD



[x4]

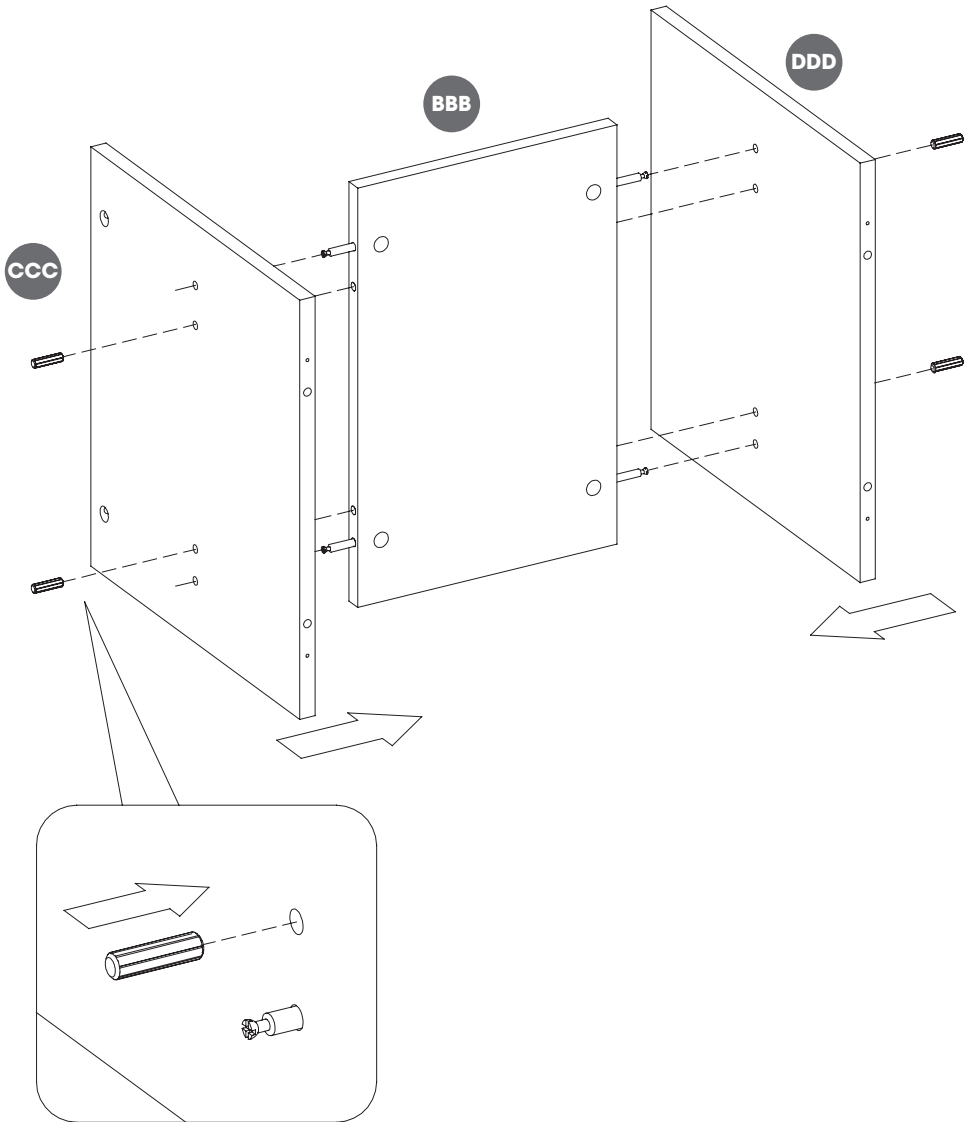

27

BB



[x4]

DD



[x4]

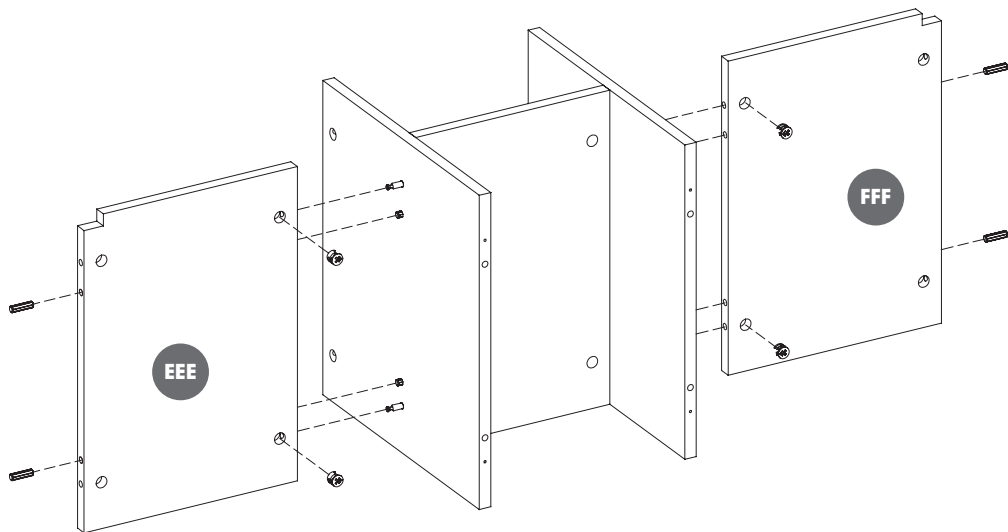
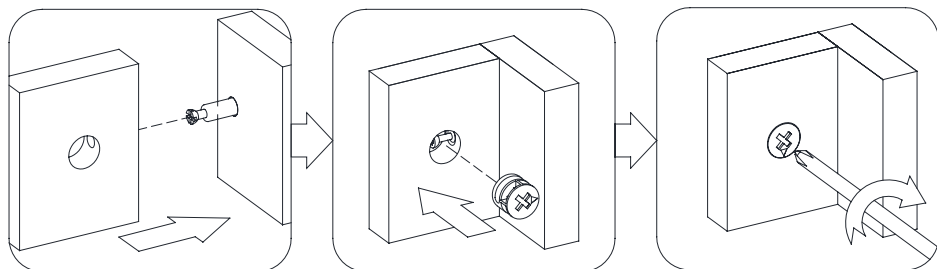

28

AA



[x6]

DD



[x4]

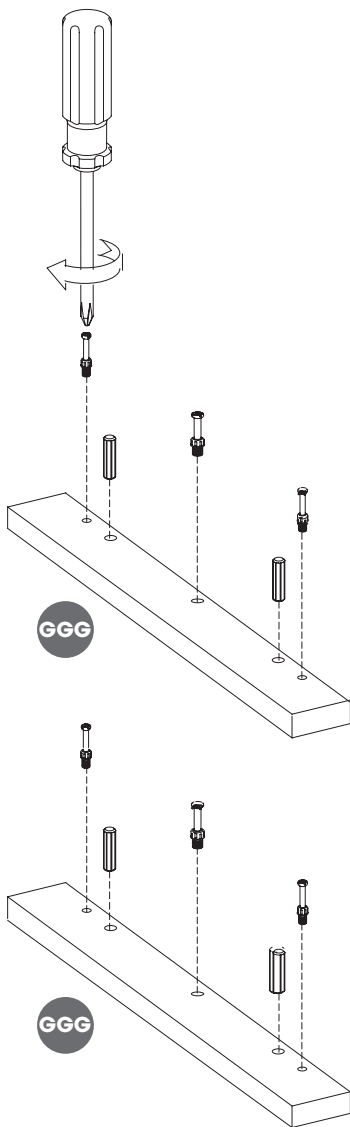

29

AA

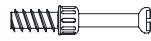

[x4]

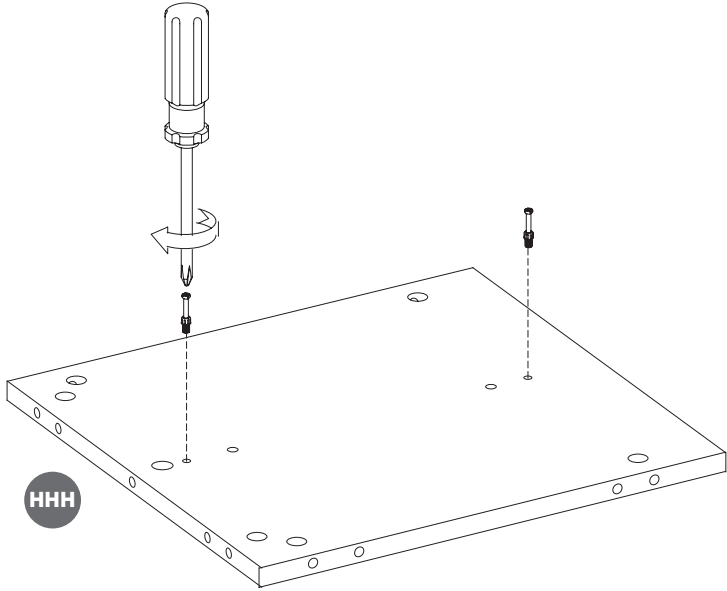

HHH

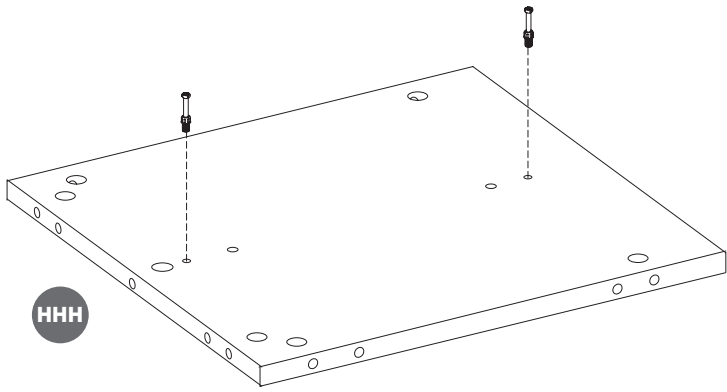

HHH

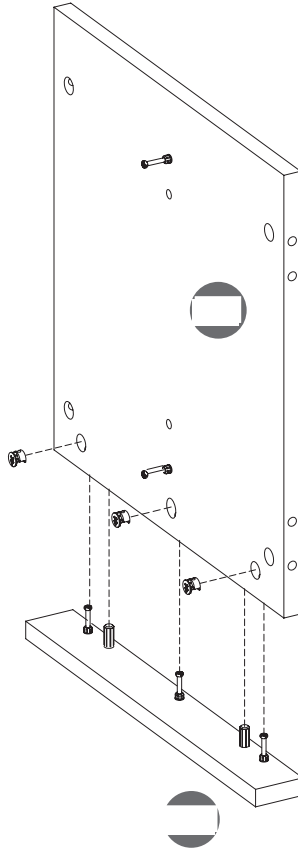
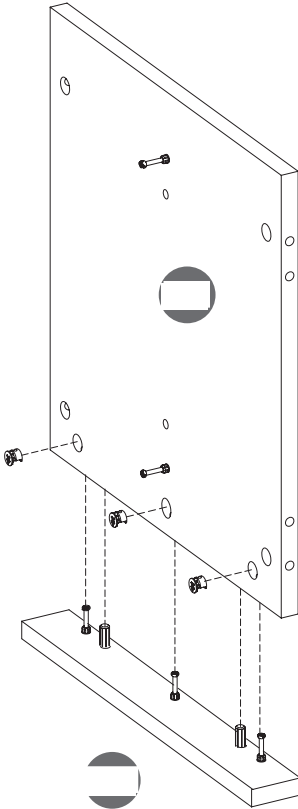
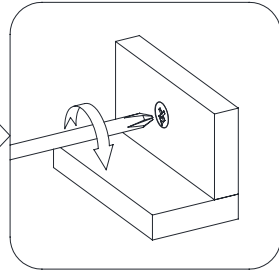
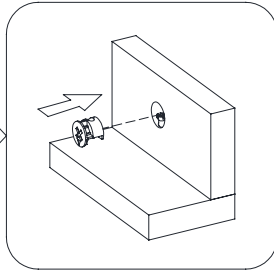
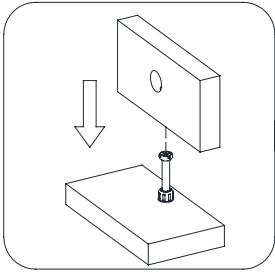

31

BB



[x4]

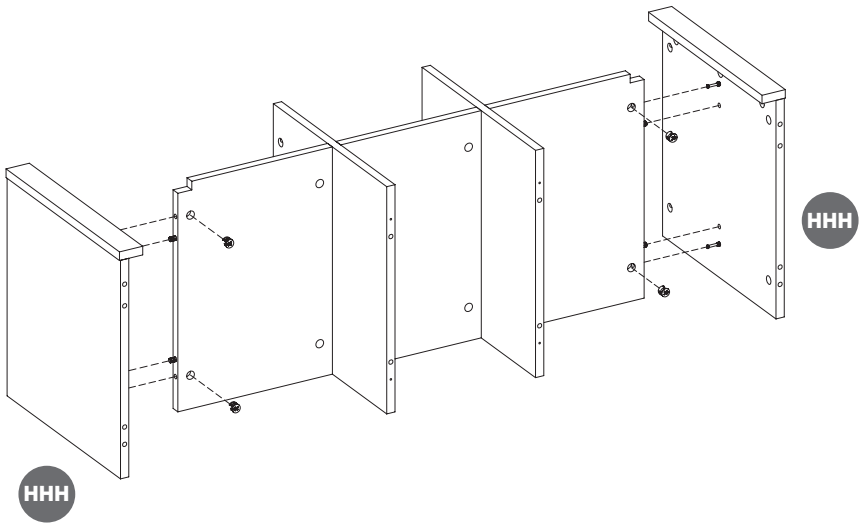
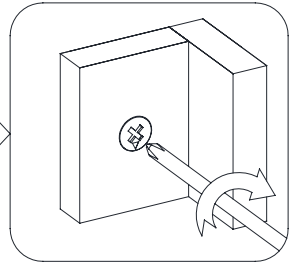
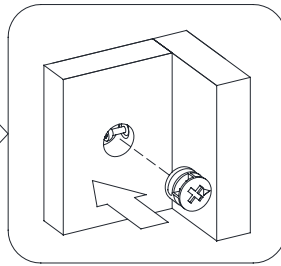
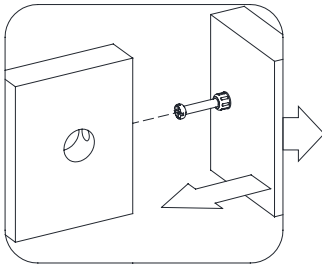

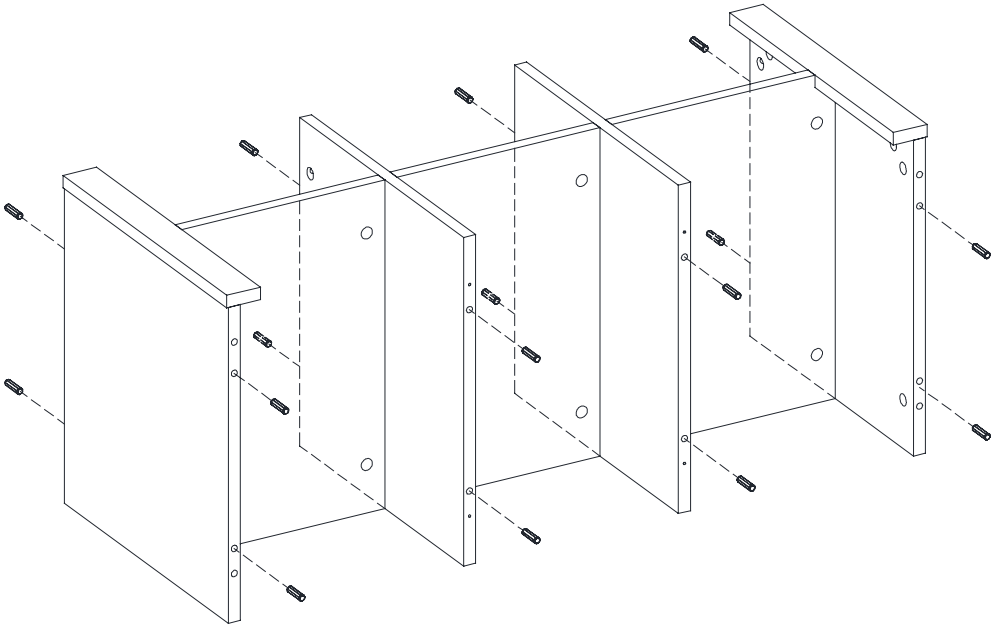
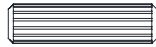

33

BB



[x8]

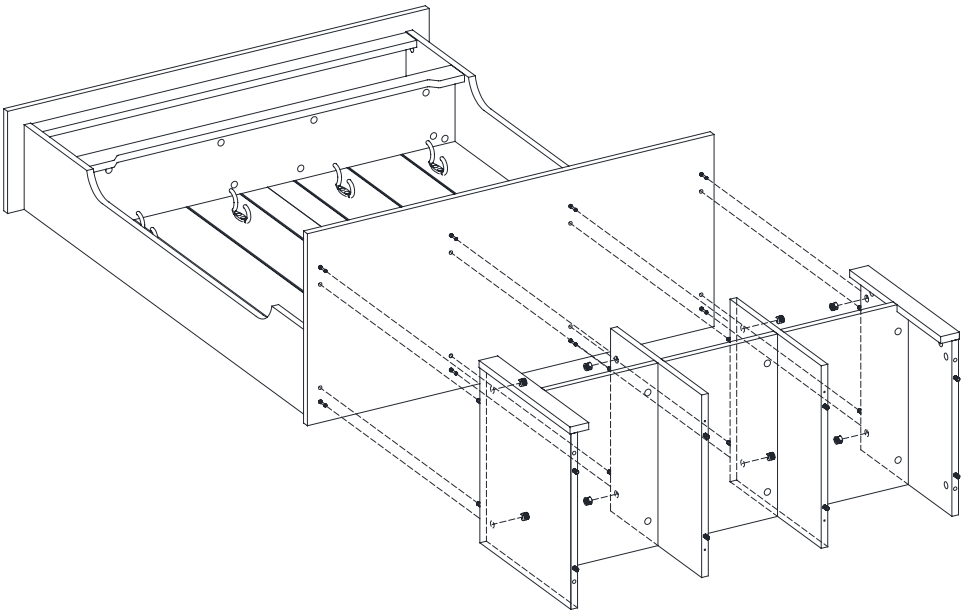
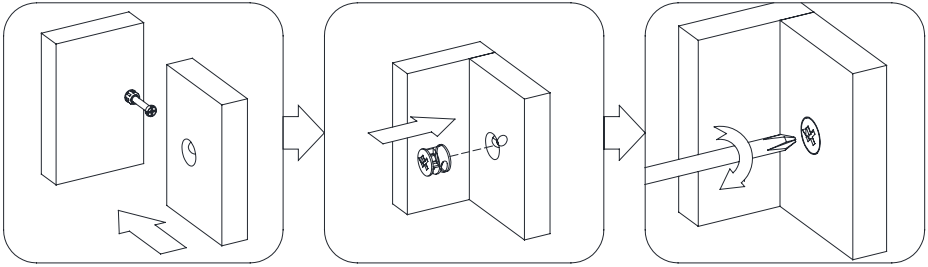

34

AA



[x4]

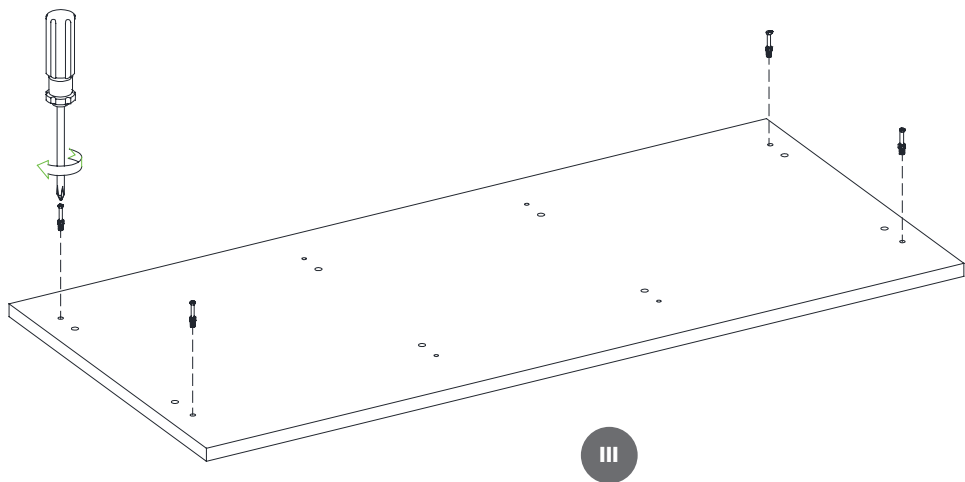

35

AA



[x10]

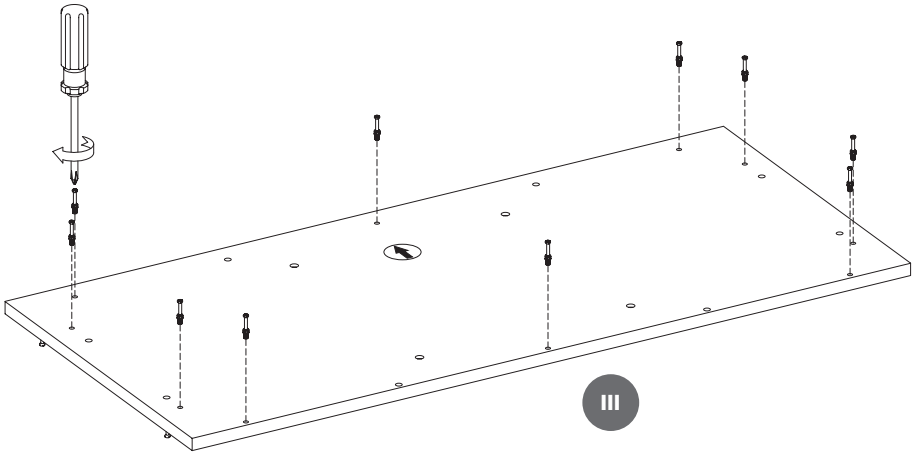

36

GG



[x4]

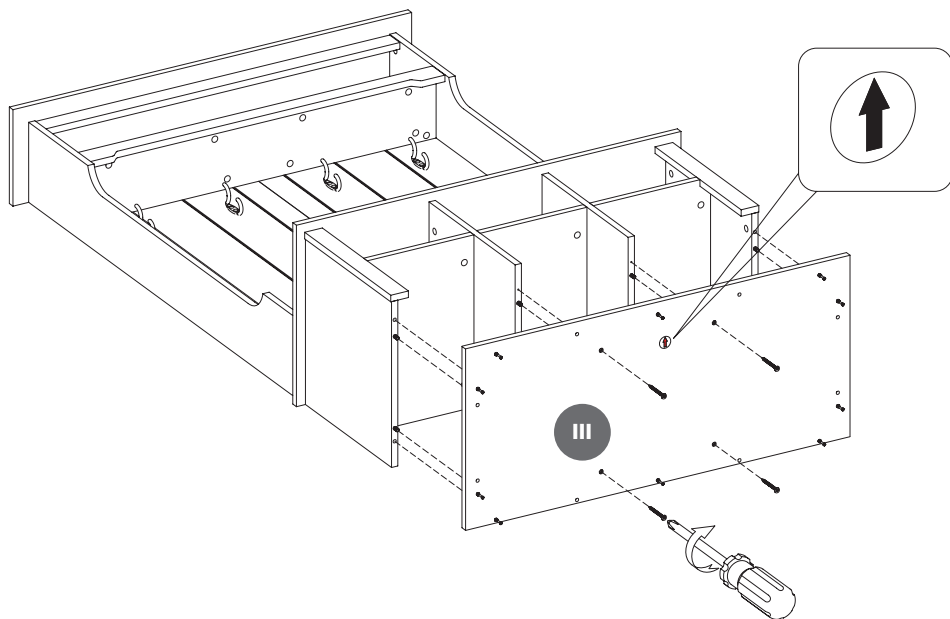

37

BB



[x4]

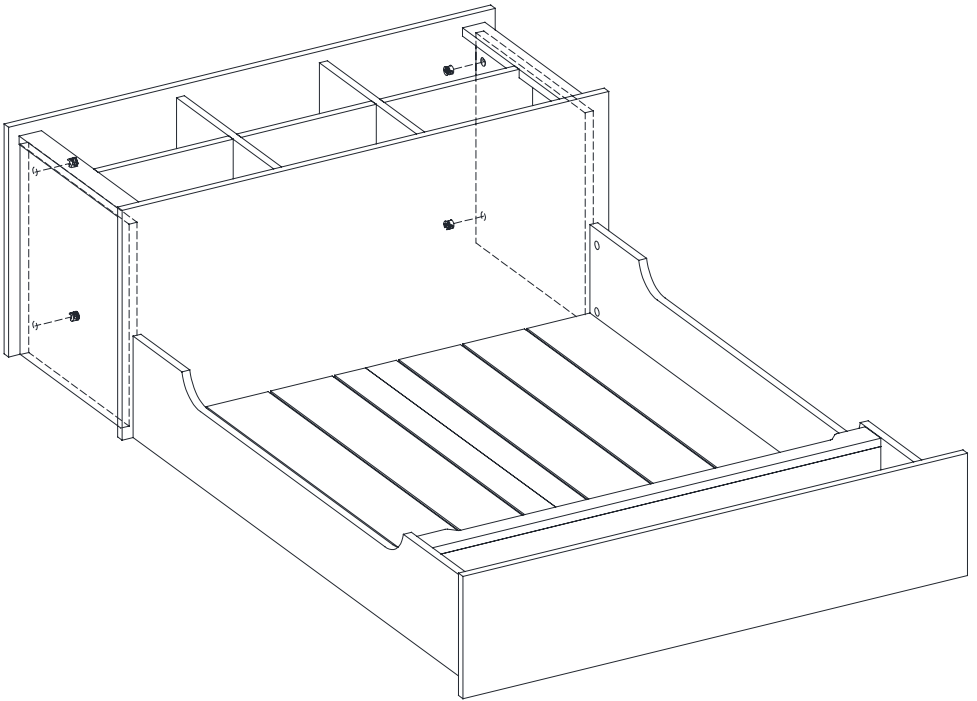
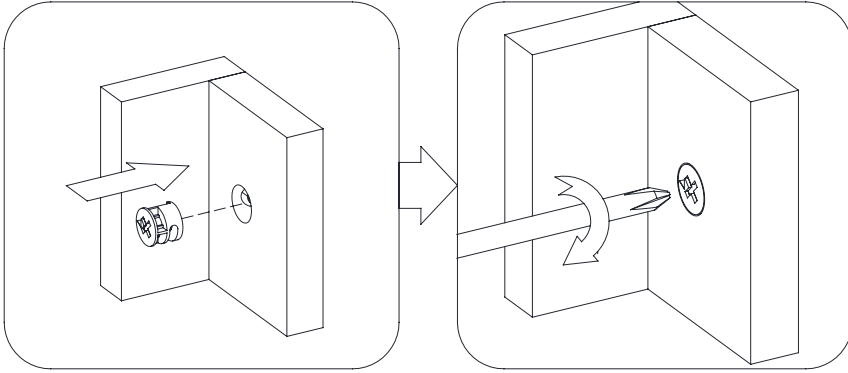

38

AA

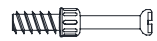

[x4]

DD



[x8]

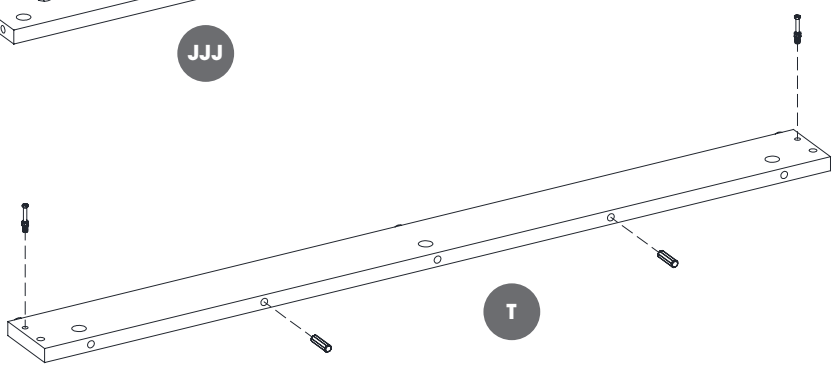
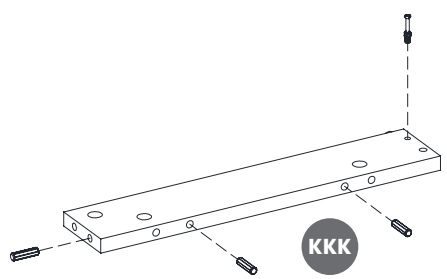
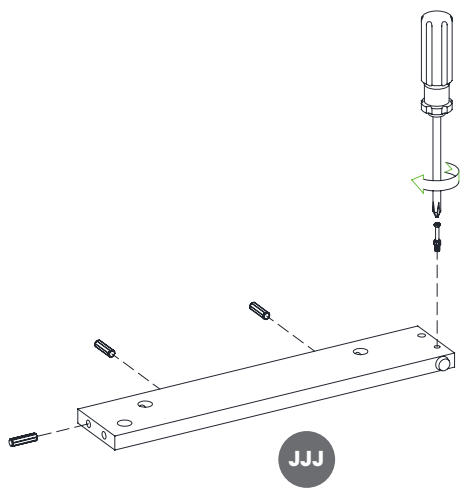

39

DD



[x4]

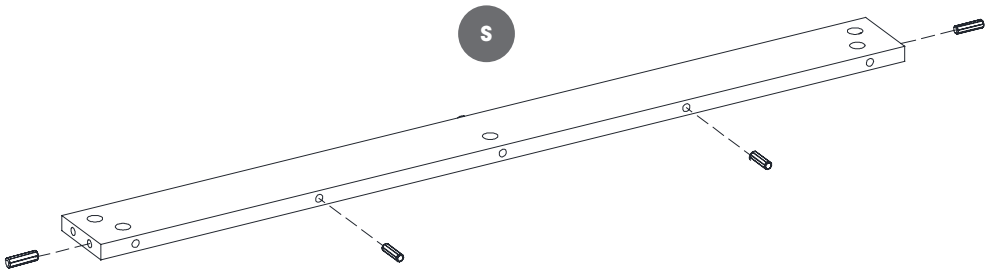

40

BB



[x2]

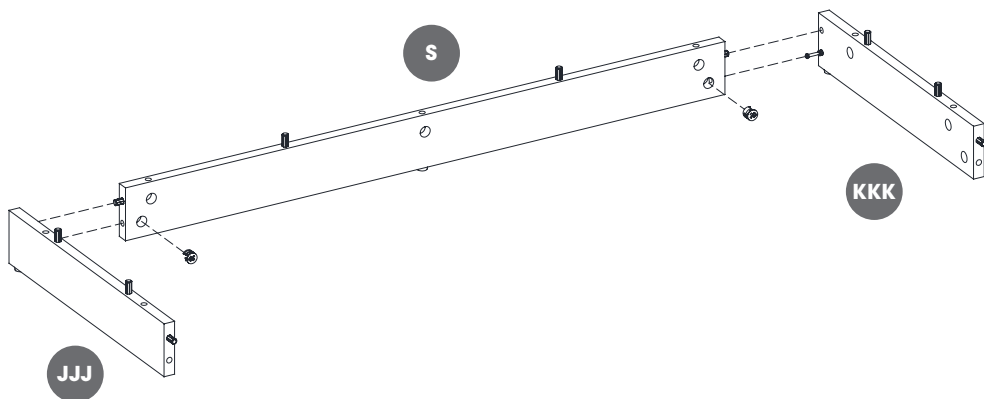
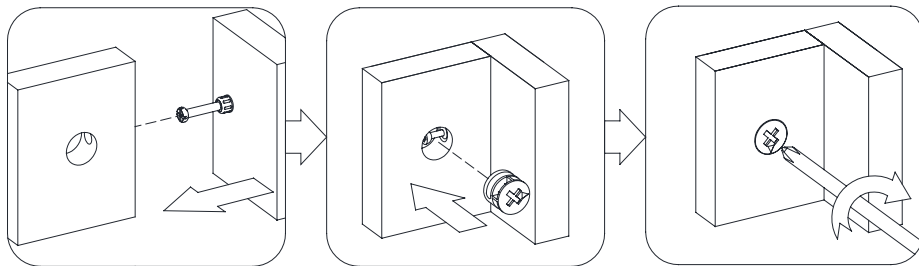

41

BB



[x2]

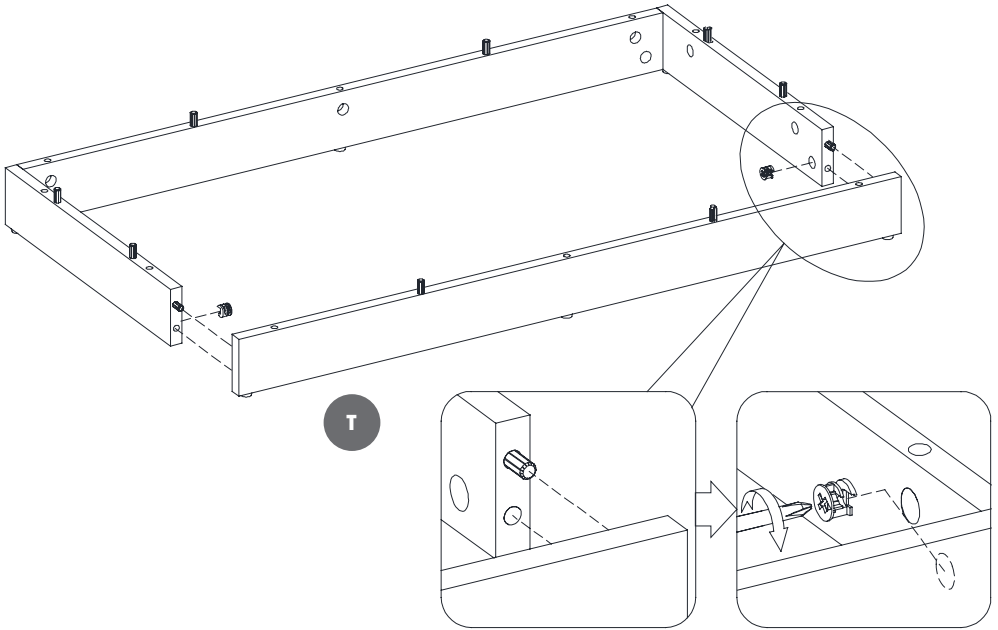

42

BB



[x10]

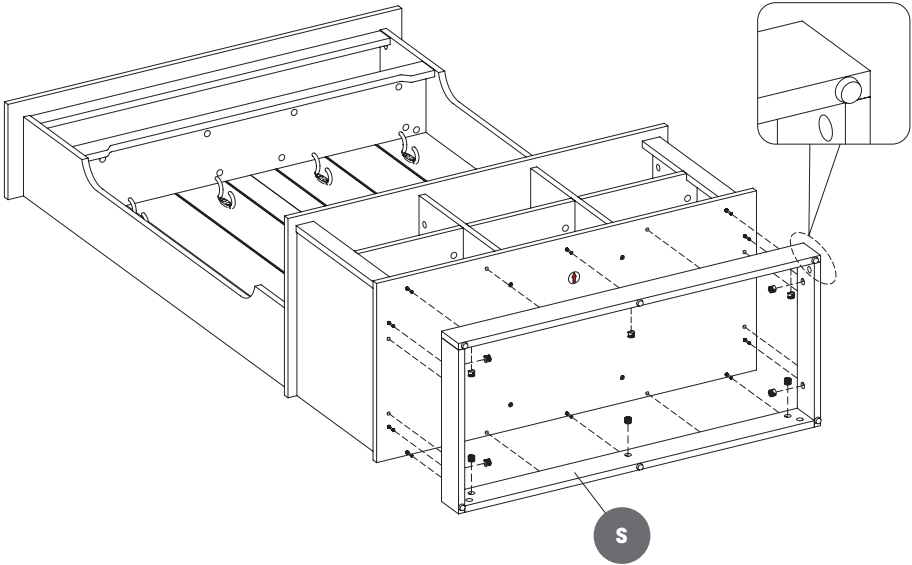
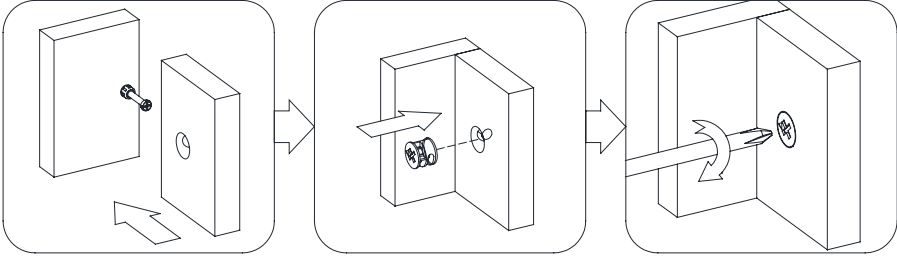

43

HH



[x36]

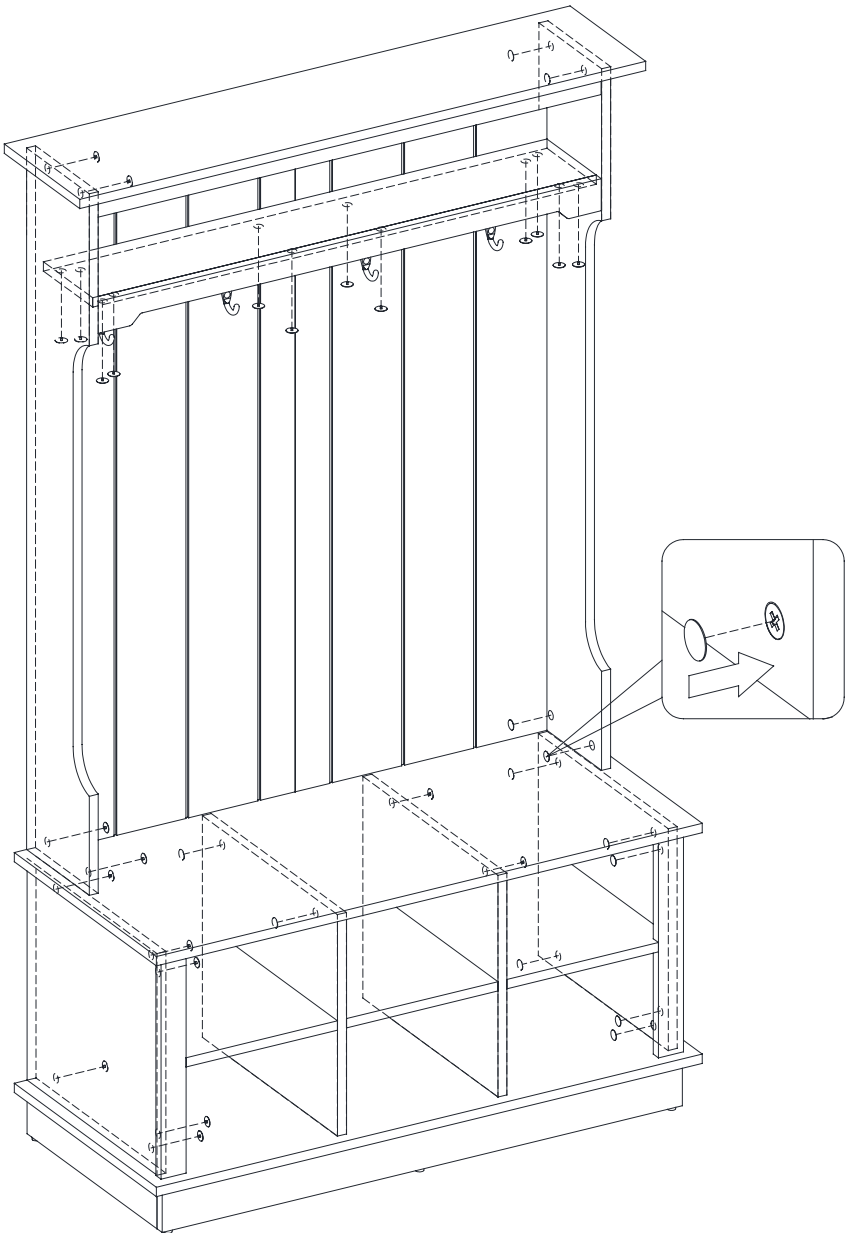

44

BB



[x4]

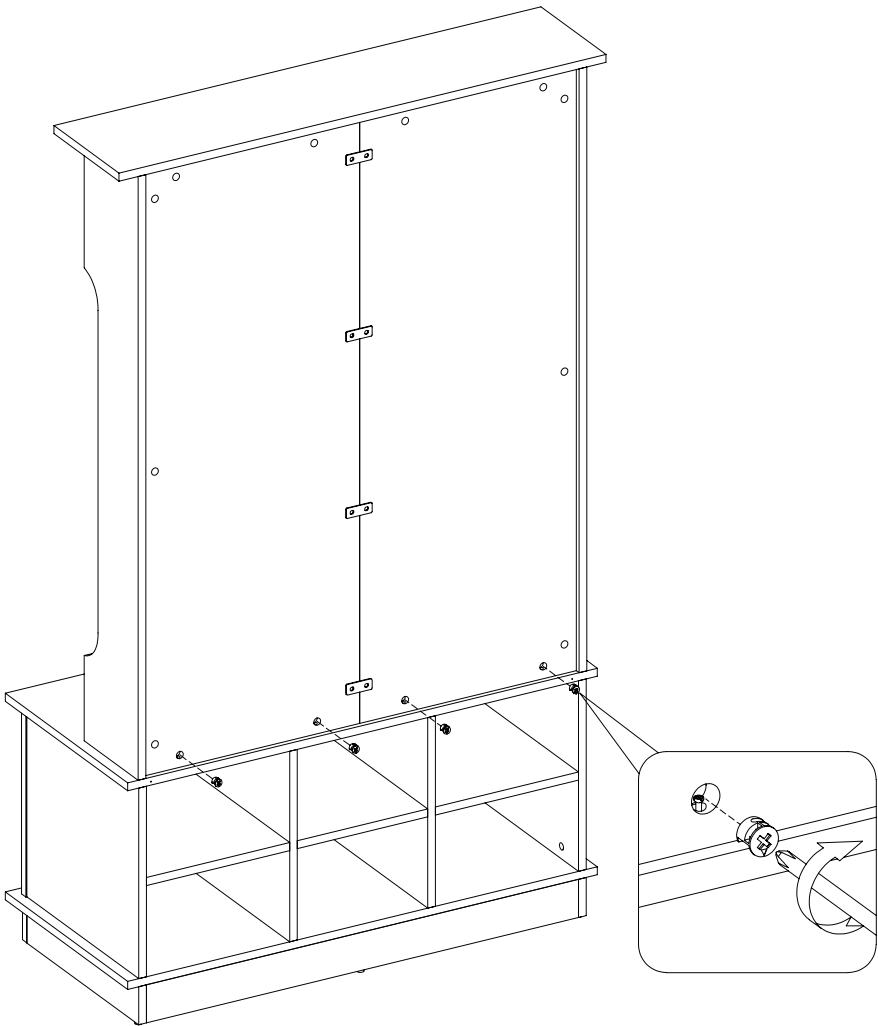

45

II



[x16]

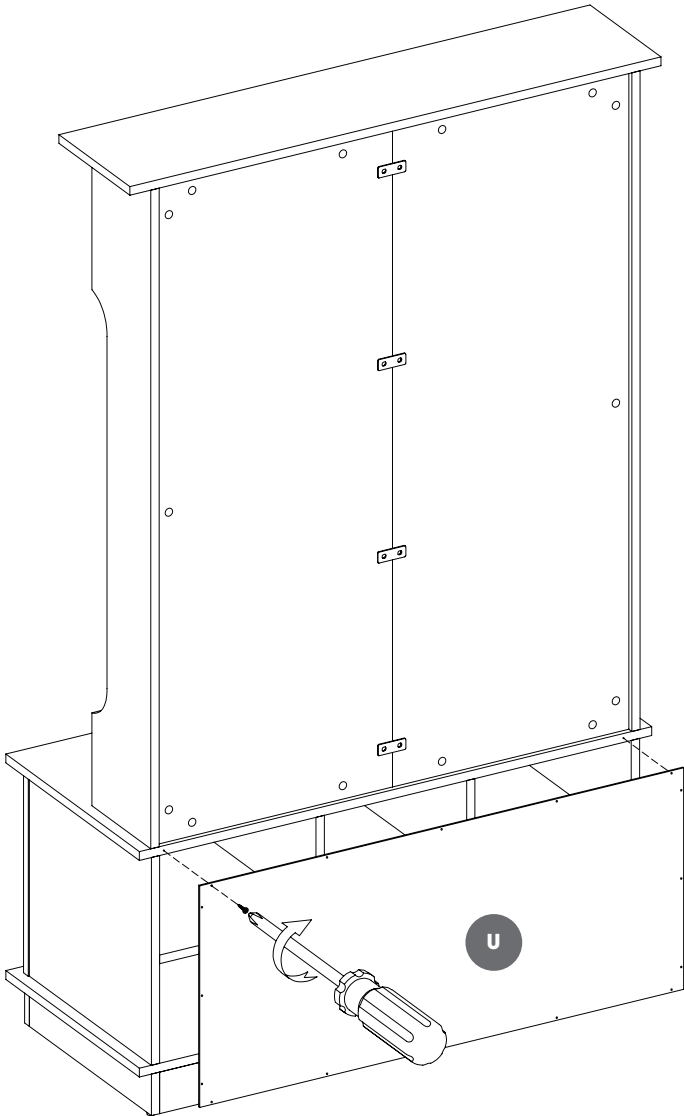

46

LL

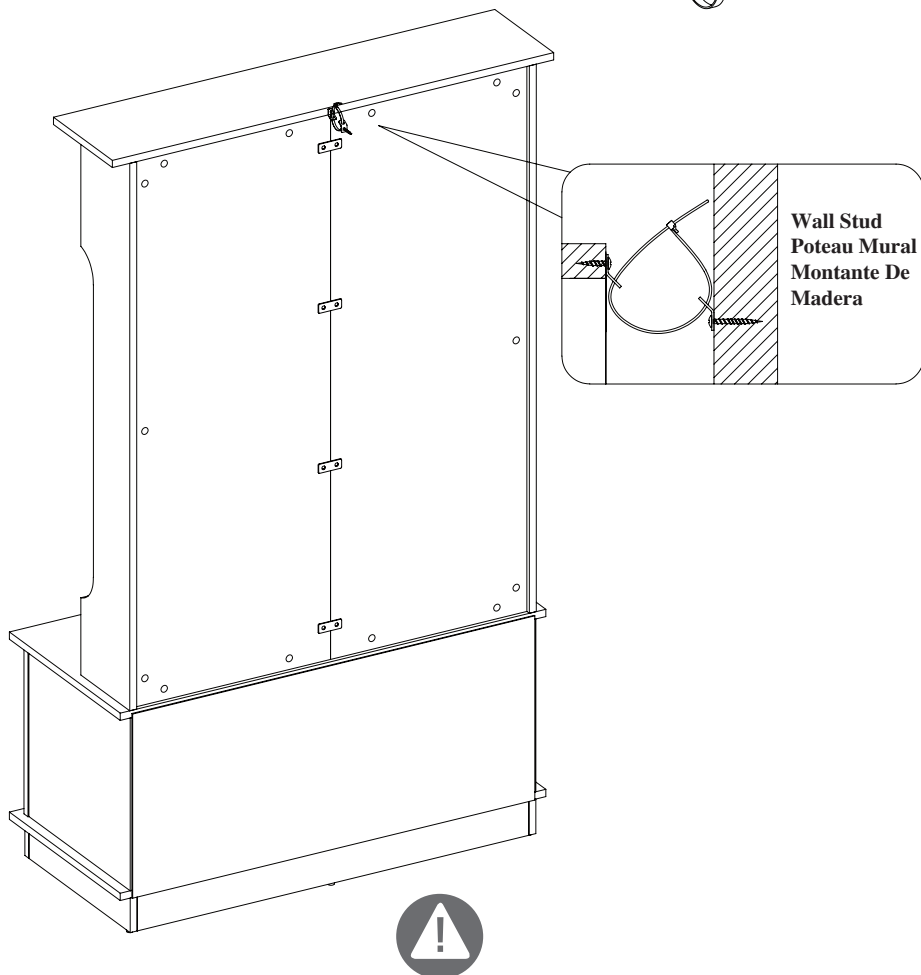
**[x1]**

Warning: You must install the tip restraint hardware to help prevent any accidents or damage to the unit. We strongly recommend attaching the tip restraint hardware to a wall stud and your unit. For all other wall types, please visit your local hardware store to obtain the proper hardware.

Avertissement: Il est nécessaire d'installer les pièces d'arrimage anti basculement pour prévenir les accidents ou les dommages à l'unité. « Nous vous recommandons fortement de fixer le support avec retenue anti-basculement à un poteau mural et à votre unité. » En ce qui concerne tous les autres types de murs, veuillez visiter votre quincaillerie pour obtenir les articles appropriés.

Advertencia: Debe instalar el Herraje contra Caídas para evitar accidentes o que se dañe la unidad. «Recomendamos enfáticamente sujetar el extremo de la herramienta de retención a un perno de pared y su unidad». Respecto de todos los demás tipos de pared, vaya a su ferretería local para obtener las herramientas adecuadas.

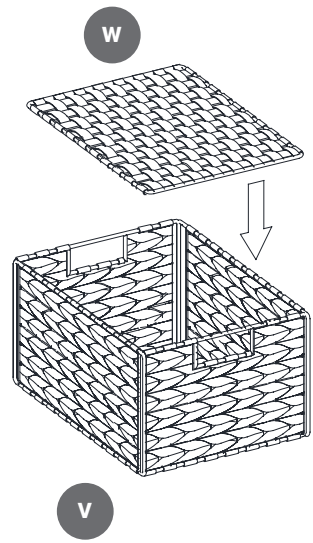
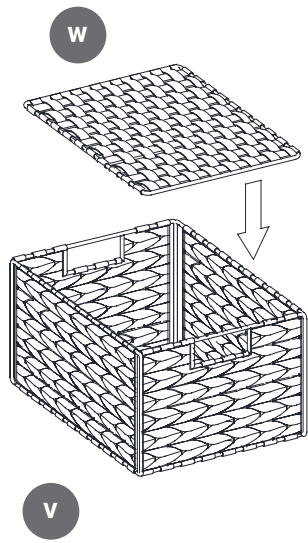
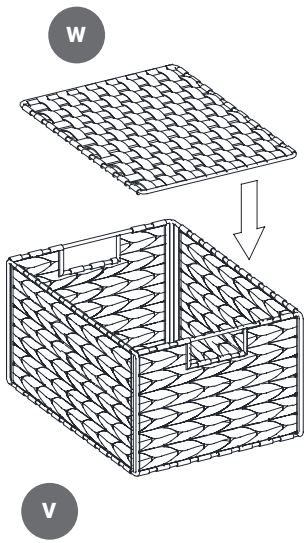

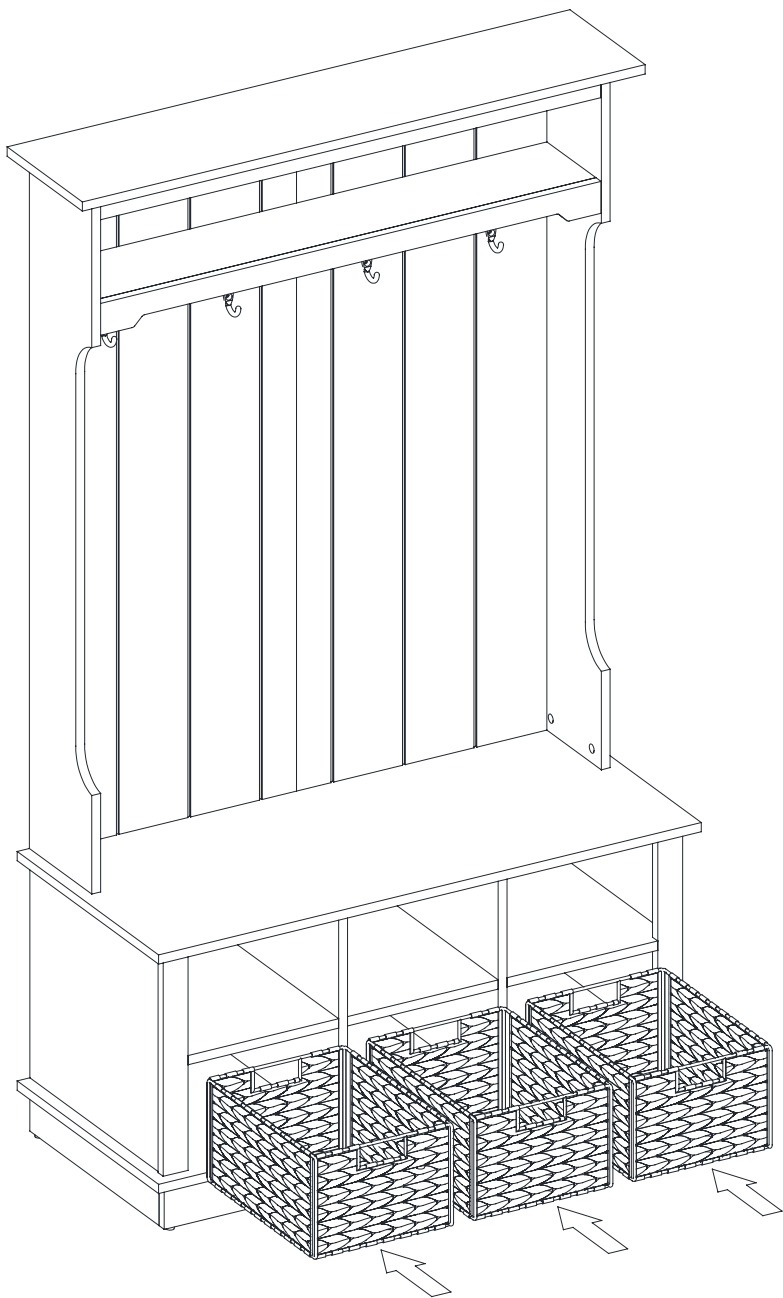

Care and Maintenance

- Use a soft, clean cloth that will not scratch the surface when dusting.
- Use of furniture polish is not necessary. Should you choose to use polish, test first in an inconspicuous area.
- Using solvents of any kind on your furniture may damage the finish.
- Never use water to clean your furniture as it may cause damage to the finish.
- Always use coasters under beverage glasses and flowerpots.
- Liquid spills should be removed immediately, as it may damage the furniture. Use a soft, clean cloth and blot the spill gently. Avoid rubbing.
- Always use protective pads under hot dishes and plates. Heat can cause chemical changes that may create spotting within the furniture.

Further advice about wood furniture care

It is best to keep your furniture in a climate-controlled environment. Temperature and humidity changes can cause fading, warping, shrinking and splitting of wood. It is advised to keep furniture away from direct sunlight as sun may damage the finish. Proper care and cleaning at home will extend the life of your purchase.

We hope you enjoy your purchase for many years. Thank you for your purchase!

Soin / Entretien

- Lors de l'époussetage, utilisez un chiffon doux et propre qui n'égatigne pas la surface.
- Il n'est pas nécessaire d'utiliser du poli à meuble. Si vous décidez d'utiliser du poli à meuble, veuillez d'abord en faire l'essai dans un endroit moins en évidence.
- L'EEE utilisation de solvant de quelque sorte sur votre ameublement peut endommager le fini.
- Ne jamais utiliser d'eau pour nettoyer votre ameublement car cela peut endommager le fini.
- Utilisez toujours des dessous de verre sous les verres/fasses des breuvages et sous les pots à fleur.
- Tout déversement de liquide doit être enlevé immédiatement car cela peut endommager l'ameublement. Utilisez un chiffon doux et propre et éponger délicatement le déversement. Évitez de frotter.
- Utilisez toujours des tampons protecteurs sous les plats et les assiettes chaudes. La chaleur peut causer des changements chimiques qui peuvent créer des taches sur l'ameublement.

Conseils supplémentaires pour l'entretien de meubles en bois

Il est préférable de garder vos meubles dans un environnement climatisé. Les changements de température et d'humidité peuvent décolorer, déformer, rétracter et fendiller le bois. Il est conseillé de garder les meubles à l'abri de la lumière directe du soleil car cela pourrait endommager le fini. EEE'entretien et le nettoyage appropriés à domicile prolongeront la vie de votre achat.

Nous espérons que vous apprécierez votre achat pendant de nombreuses années. Nous vous remercions pour votre achat!

Cuidado / Mantenimiento

- Use un paño suave y limpio que no raye la superficie cuando elimine el polvo.
- El uso de cera para muebles no es necesario. Si elige utilizar la cera, realice primero una prueba en un área discreta.
- Usar solventes de cualquier clase en sus muebles puede dañar el acabado.
- Nunca utilice agua para limpiar sus muebles, ya que puede causar daños en el acabado.
- Siempre utilice posavasos para colocar los vasos de bebidas y las macetas.
- Los derrames de líquidos se deben de secar inmediatamente, ya que pueden dañar el mueble. Use un paño suave y limpio y seque el derrame con cuidado. Evite frotar.
- Siempre utilice almohadillas protectoras debajo de los platos y vajillas calientes. El calor puede causar cambios químicos los cuales pueden crear manchas en los muebles.

Consejos adicionales sobre el cuidado de los muebles de madera

Lo mejor es mantener sus muebles en un ambiente con clima controlado. Los cambios de temperatura y humedad pueden hacer que la madera se decolore, se combe, se encoja y se parta. Se aconseja mantener los muebles alejados de la luz solar directa, ya que esta puede dañar el acabado. El cuidado y la limpieza adecuados en casa extenderán la vida útil de su compra.

Esperamos que disfrute de su compra durante muchos años. ¡Gracias por su compra!